

See discussions, stats, and author profiles for this publication at: <https://www.researchgate.net/publication/331345867>

# DEVELOPMENT OF MEMS BASED POCKET FACTORY FOR SUSTAINABLE MANUFACTURING SYSTEM

Book · February 2019

---

CITATION

1

---

READS

1,107

4 authors, including:



**Ttm.Kannan Mahadevan**  
PRIST University

75 PUBLICATIONS 325 CITATIONS

SEE PROFILE



**Kamaraj Chandrasekaran**  
MAM School of Engineering, Tamilnadu, India.

44 PUBLICATIONS 274 CITATIONS

SEE PROFILE

# **DEVELOPMENT OF MEMS BASED POCKET FACTORY FOR SUSTAINABLE MANUFACTURING SYSTEM**

**Dr.TTM.KANNAN, M.Tech.,Ph.D.,**  
Associate professor, Department of Mechanical Engineering  
MAM School of Engineering, Tiruchirappalli, Tamilnadu, India.

**Dr.P.RANJITH KUMAR, M.E,Ph.D.,**  
Professor & Principal  
MAM School of Engineering, Tiruchirappalli ,Tamilnadu, India.

**Dr.K.CHANDRASEKARAN, M.E, Ph.D.,**  
Associate professor, Department of Mechanical Engineering  
MAM School of Engineering, Tiruchirappalli, Tamilnadu, India.



As per the latest Syllabus of Anna University, Chennai (Regulation-2017)

# ELECTRICAL DRIVES AND CONTROLS

For B.E. III Semester Mechanical Engineering

With  
Latest Solved  
Anna University  
Question Papers



**ARS PUBLICATIONS**  
CHENNAI

**Dr.N.Dhanasekar**  
**Dr.P.Avirajamanjula**

1. Environmental Studies book

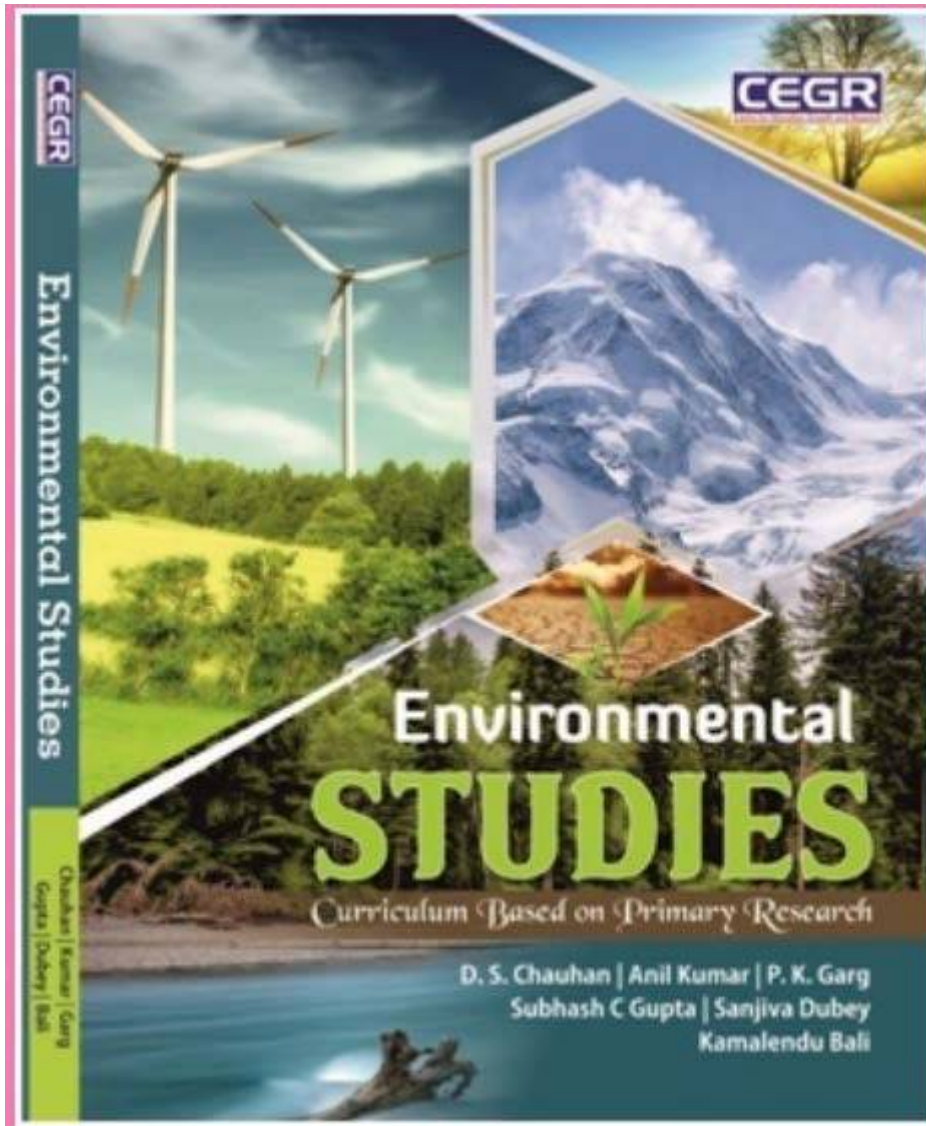

**Authors** : Dr. Ashutosh Das

**ISBN** : 978-8193-574003

**Year** : 2018

2. Medicinal Plants for Promising future for health and new drugs

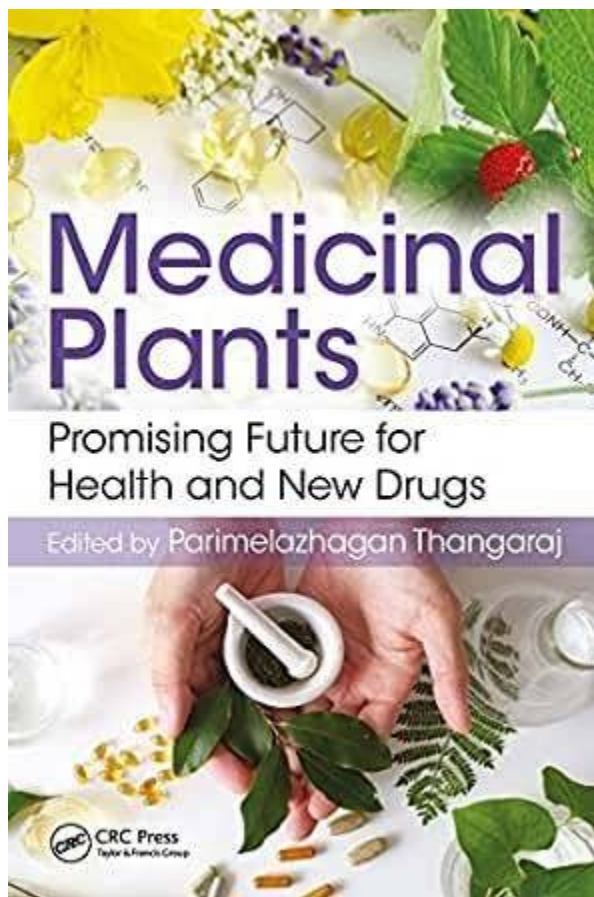

**Author's list :**

Masilamani Sri Devi, Krishnamoorthy Vinothini, Blassan P. George, Sudharshan Sekar, Arjun Pandian and Heidi Abrahamse

**ISBN : 9781351046510**

**Year : 2018**

**Department : Bio-Chemistry and Bio-Technology PRIST University.**

## Content Page :

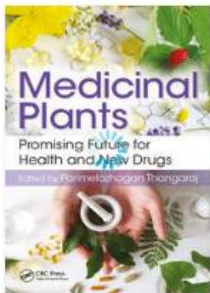

Chapter

# In Vitro Calli Induction, Biomass Accumulation and Different Biological Activity of *Leucas aspera* (willd.) Linn.

By Masilamani Sri Devi, Krishnamoorthy Vinothini, Blassan P. George, Sudharshan Sekar, Heidi Abrahamse, Bettine van Vuuren, Arjun Pandian

Book [Medicinal Plants](#)

Edition	1st Edition
First Published	2018
Imprint	CRC Press
Pages	20
eBook ISBN	9781351046510

---

## ABSTRACT

*Leucas aspera* (willd.) Linn, belongs to Lamiaceae family and is a branched herbaceous plant, which is herb erected, stout and has a hispid acutely quadrangular stem and branches. The plant is used traditionally as an insecticide and antipyretic, the leaves are used for psoriasis, chronic skin eruptions, snakebites, gastrointestinal disorders and respiratory tract disorders. The seeds and in vitro calli were shade-dried and powdered; the powdered samples were cold macerated with different solvents for 3d with occasional stirring. Different concentrations of the leaf, stem and in vitro calli were loaded into the wells using a sterile micropipette. The antimicrobial activity by the zone of inhibition was observed and carried out for wild leaves, stems and in vitro calli in different solvents and extracts against the human pathogens *B. subtilis*, *S. aureus*, *E. coli*, *S. typhi*, *V. cholera* and *C. krusei*. The chapter concludes that work that the explants of *L. aspera* showed profuse in vitro biomass accumulation and root formation.



3. Medicinal Plants for Promising future for health and new drugs

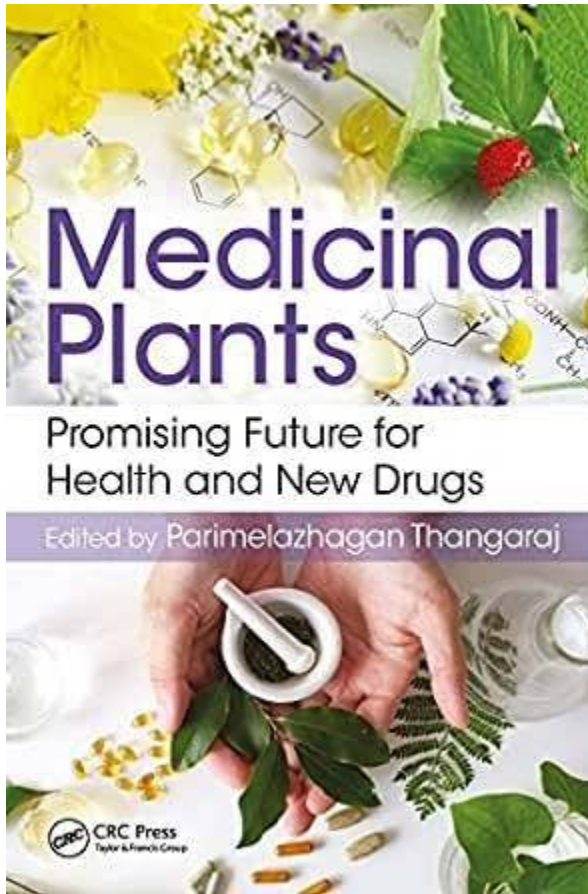

**Author's list :**

Krishnamoorthy Vinothini, Masilamani Sri Devi, Sudharshan Sekar, Blassan P. George, Pandian Arjun, Vuyo Mavumengwana, Heidi Abrahamse

Year : 2018

ISBN : **9781351046510**

**Department : Bio-Technology PRIST University.**

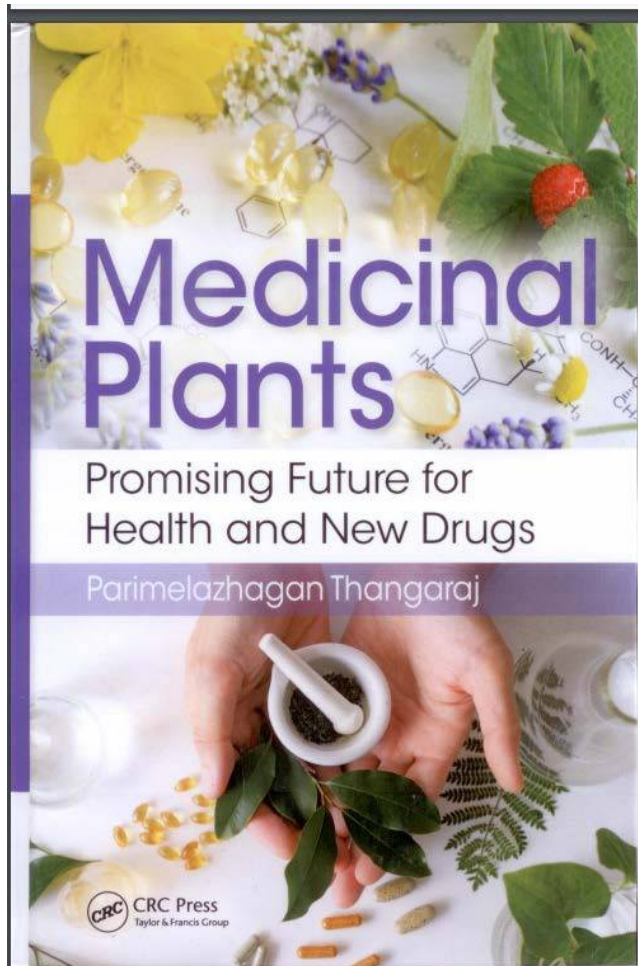

<b>Chapter 19</b> <i>In Vitro</i> Plant Regeneration, Comparative Biochemical and Antioxidant Potential of Calli and Seeds of <i>Sesbania grandiflora</i> (L.) Poiret.....	355
<i>Krishnamoorthy Vinothini, Masilamani Sri Devi, Sudharshan Sekar, Blassan P. George, Heidi Abrahamse, Bettine van Vuuren and Arjun Pandian</i>	
<b>Index</b> .....	379

#### 4. Noncovalent Interactions in Catalysis

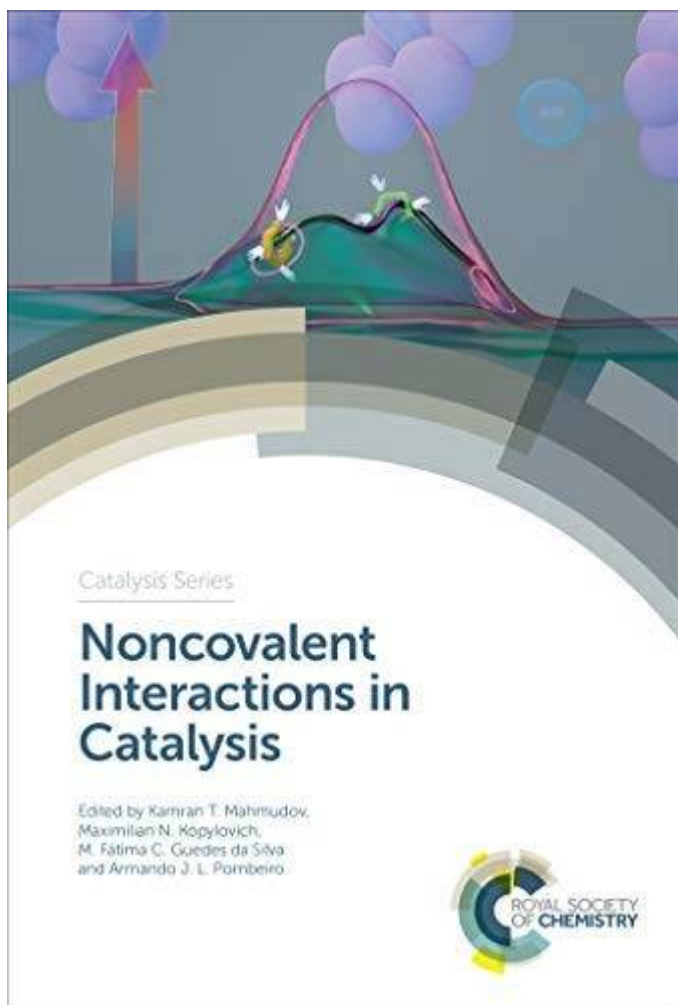

#### CHAPTER 28

Chapter 28 : Noncovalent Interaction in Biocatalysts – A Theoretical Perspective

Authors : Gunasekaran Velmurugan, Rajadurai Vijay Solomon, **Dhurairajan Senthilnathan** and Ponnambalam Venuvanalingam

**Pages : 608 - 627**

ISBN : 978-1-78801-468-7

Department : Chemistry Department

YEAR : 2019

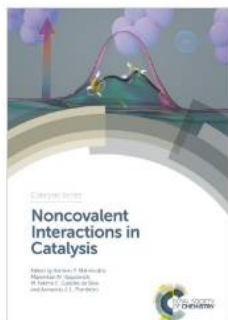

CATALYSIS SERIES

### Noncovalent Interactions in Catalysis



**Edited by** Kamran T Mahmudov;  
Maximilian N Kopylovich;  
M Fatima C Guedes da Silva;  
Armando J L Pombeiro

**DOI:** <https://doi.org/10.1039/9781788016490>

**Hardback ISBN:**  
978-1-78801-468-7

**PDF ISBN:** 978-1-78801-649-0

**Epub ISBN:** 978-1-78801-751-0

**Special Collection:** 2019 ebook collection

**Series:** Catalysis Series

**No. of Pages:** 653

**Publication date:** 04 Mar 2019

BOOK CHAPTER

## CHAPTER 28: Noncovalent Interactions in Biocatalysis – A Theoretical Perspective



By Gunasekaran Velmurugan ; Rajadurai Vijay Solomon ; Dhurairajan Senthilnathan ; Ponnambalam Venuvanalingam

**DOI:** <https://doi.org/10.1039/9781788016490-00608>

**Published:** 04 Mar 2019

**Special Collection:** 2019 ebook collection

**Series:** Catalysis Series

Get permissions

Cite

Share

Noncovalent interactions (NCIs) are Nature's choice for maintaining biological structure and carrying out many biological functions. These delicate forces become stronger and more specific when acting together. They were detected very early as short contacts in crystals or in gas-phase complexes but their systematic understanding is recent. Theoretical methods have greatly aided in understanding their nature and variety and this eventually led to their use in developing chemical, material, biological and technological applications. Recent developments in computer hardware and software have enabled scientists to probe the movements at the atomic level in the active site of complex biological systems and understand the biological processes. This chapter is devoted to explaining the role of NCIs in biocatalysis from a computational perspective. It first introduces the popular theoretical methods used to characterize NCIs and then explains the role of the three main NCIs, namely hydrogen bonding, halogen bonding and hydrophobic interactions, in biocatalysis through six case studies from the literature. The chapter ends with a summary and future directions of this topic.

You do not currently have access to this chapter, but see below options to check access via your institution or sign in to purchase.



5. Tamil Illakkiyangalum Samuthaya Matranganalum

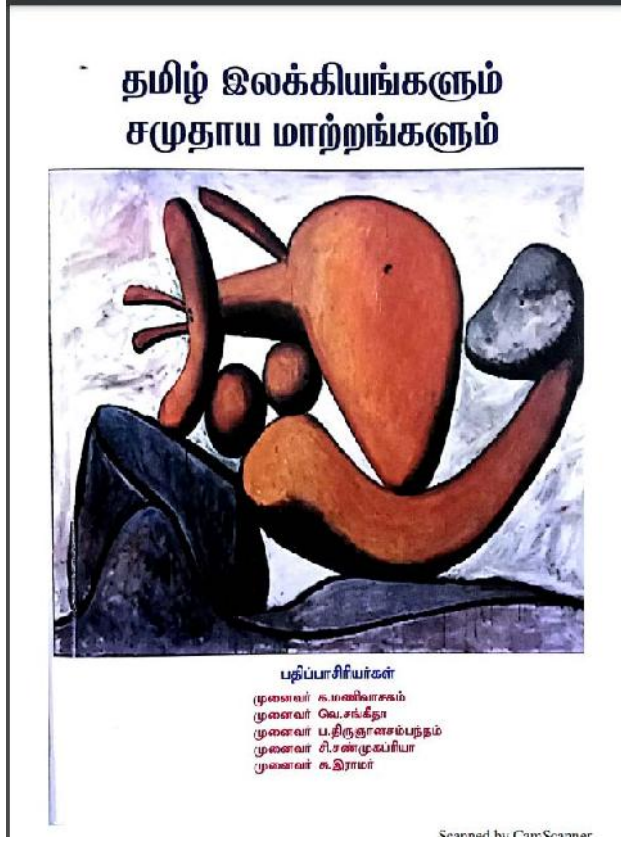

Authors : Dr.R.Sasikala

ISBN : 978-93-86568-38-0 (Scholars Forum, Tamilology of Madurai Kamaraj  
University

Year : 2018

நூல் விவரம்

நூலின் பெயர்	- தமிழ் இலக்கியங்களும் சமுதாய மாற்றங்களும்
பதிப்பாசிரியர்கள்	- முனைவர் க.மணிவாசகம் முனைவர் வெ.சங்கீதா முனைவர் ப.திருஞானசம்பந்தம் முனைவர் சி.சண்முகப்ரியா முனைவர் க.இராமர்
நூலின் தன்மை	- ஆய்வரங்கக் கட்டுரைகள்
மொழி	- தமிழ், ஆங்கிலம்
முதல் பதிப்பு	- அக்டோபர் 2018
பதிப்புரிமை	- பதிப்பாசிரியர்களுக்கு
வெளியீடு	- முதுமுனைவர்ப்பட்ட ஆய்வாளர்கள் தமிழியற்புலம் மதுரை காமராசர் பல்கலைக்கழகம் மதுரை - 625021
அளவு	- 1/8 டெம்மி
ISBN	- 978-93-86568-38-0
பக்கங்கள்	- 679
விலை	- 650
அச்சாக்கம்	- ஷான்லாக்ஸ் பிரின்டர்ஸ் , மதுரை.
நூல் வடிவமைப்பு	- சோ.அறிவுமணி

குறிப்பு : இந்நூலில் இடம்பெறும் கட்டுரைக் கருத்து அந்தந்த  
கட்டுரையாளர்களுடையது.

## சங்ககால இலக்கியங்களும், இக்கால மாற்றங்களும்

முனைவர். இரா. சசிகலா  
தமிழ்ந்துறை  
பிரிஸ்ட் பல்கலைக்கழகம்  
வல்லம் - தஞ்சாவூர்.

சங்க இலக்கியத்தில் இப்படிதான் வாழவேண்டும் என்று வரையரை இருந்தது. ஆனால் இக்காலத்தில் எப்படிவேண்டுமானாலும் வாழலாம் என்று வாழ்ந்து வருகின்றனர். காரணம், அன்று சமுதாய அக்கறை, நலன் இருந்தது. இன்று மக்கள் சுயநலமாக வாழ்ந்து வருகின்றனர். தனக்காகவும், தன் குடும்பத்தினருக்காகவும் மட்டுமே வாழ்ந்து வருகின்றனர்.

"வினையே ஆடவர்க்கு உயிரே" அன்று சங்க இலக்கியத்தில் சொல்லி இருக்கிறார்கள். ஒரு ஆண்மகனுக்கு வேலை என்பதுதான் உயிர் என்று கூறியுள்ளார். ஆனால் இன்றைய சில ஆண்மகன் வேலை பார்ப்பதற்கு மிகவும் சோம்பேறியாக உள்ளனர். இருக்கின்ற வருமானத்தை வைத்து வாழ வேண்டும் என்ற எண்ணம் இல்லாமல் 'ஆடம்பரம்' என்ற வார்த்தையில் அடிமைப்பட்டு வாழ்ந்து வருகின்றனர்.

**பக்திநிலை**

ஆழ்வார், நாயன்மார் காலத்தில் இந்தநிலையில் மாறுதல் ஏற்படத் தொடங்கியது. இல்லறத்தில் ஈடுபட்டாலும் இறைவனிடம் பக்தி பூண்டெழுதிய அடியவர்களுக்கே மதிப்பு ஏற்பட்டது. துறவிகளும், உலகை வெறுக்காமல், அவர்களுடன் இணைந்து கோயில் வழிபாடு செய்துவந்தனர். ஆனால் இன்று இந்தநிலைமாறிவிட்டது.

இன்றைய துறவிகளும், தமக்கென ஒரு அமைப்பையும், மடங்களும் நிறுவி பொன்னும், பொருளும் சேர்த்து விருந்தோம்பல் ஆன்மீக வல்லுநர்களைப் போற்றுதல் போன்ற பல அறங்கள் நடத்தி துறவிகள் என்ற வார்த்தைக்கே இழுக்கு ஏற்படுத்தியிருக்கின்றன. காரணம் இங்கேயும் சுயநலம்தான். சுயநலம் என்ற வார்த்தைக்கு அடிப்படையாக எல்லோரும் வாழ்ந்து வருகின்றனர்.

தமிழ் இலக்கியங்களும் சமுதாய மாற்றங்களும் | 211

# NATURE AND ROMANTICISM

*Edited by*

**DR.K.SHIBILA**



978-93-6255-160-3

# **NATURE AND ROMANTICISM**

**Copyright © 2018**

**by K.SHIBILA**

**All rights reserved. No part of this book may be reproduced or transmitted in any form or by any means without written permission from the author.**

**ISBN: 978-93-6255-160-3**

**Publisher: Ponnaiyah Ramajayam Institute of Science and  
Technology  
(PRIST)**



<b>CONTENT</b>	<b>PAGE</b>
<b>BOOK –I NATURE AND ROMANTICISM</b>	<b>1-6</b>
<b>CHAPTER-1</b> The Characteristics of the Romanticism in Wordsworth	
Chapter-2 Nature as the Mean of Expression in Romanticis DR.N PREMA	7-9
<b>CHAPTER –3</b> Wordsworth Romanticism in "Tintern Abbey" DR.N.SUBRAMANIAN,	<b>10-13</b>
<b>CHAPTER-4</b> Symbolism in Romantic Poetry DR.E.GEETHA	<b>14-19</b>
<b>CHAPTER –5</b> REALISM NAD ROMANTICISM:SIMILARITIES AND DIFFERENCES Dr.R.A. RAJASEKARAN,	<b>20-25</b>
<b>CHAPTER-6</b> "Tintern Abbey" by William Wordsworth as a Romantic Poem. MS.R.VISALAKSHI	<b>26-29</b>
<b>CHAPTER- 7</b> "Kubla khan" as a romantic poem. DR.G.KARTHIKA	<b>30-34</b>
<b>CHAPTER –8</b> Poetic Devices and ; Figurative Languages in P B Shelley. "Ode to the West Wind" MS.K.JAYAPRIYA	<b>35-39</b>
<b>CHAPTER-9</b> The Imaginative Power Of Keats In "Ode To A Nightingale". DR.D.RAVI KUMAR	<b>40-43</b>
<b>CHAPTER-10</b> The uses of Romanticism in <i>The Raven</i> , a poem by Edgar Allan Poe MR.M.AMAL RAJ	<b>44-47</b>
<b>CHAPTER-11</b> The Significance of Philosophy in literature MR.S.RASAKUMAR	<b>48-52</b>
<b>CHAPTER-12</b> The Transformative Power of the Imagination <i>Kubla Khan</i> DR. N.MEENURAJATHI	<b>53-56</b>
<b>CHAPTER-13</b> Theme of spontaneous in wordsworth's "The Tintern Abbey". MR.T.THIRUPPATHI	<b>57-59</b>
<b>CHAPTER-14</b> EDGAR ALLAN POE AS AN AMERICAN ROMANTISICIM WRITER MR.P.KINGSLEY PREM	<b>60-64</b>
<b>CHAPTER-15</b> Imagination and creativity in wordsworth's " <i>The Tintern Abbey</i> " MS.M.THAMIZHMANI	<b>65-68</b>

---

**CHAPTER-1**

---

**The Characteristics of the Romanticism in Wordsworth****Dr. K. Shibila****Professor, Department Of English, Prist Deemed To Be University, Thanjavur.**

---

**Abstract:**

The term "Romantic" is derived from the old French 'Romans' and is denoted as a vernacular language derived from the Latin word that provides us the expression "the Romance languages", but it came to mean more than a language. It not only meant an imaginative story and a courtly romance but also implies the quality and preoccupations of literature written in "the Romance languages", especially romances and stories. However, day by day, it came to mean so many other things also. By the seventeenth century in English, the French word "romantic" had come to mean anything which is from imaginative or fictitious, fabulous or extravagant, fanciful or bizarre, exaggerated and fanciful. The adjective "roman-tic" was also used with the connotation of disapproval. In the eighteenth century, it was increasingly used with various connotations of approval, especially in the descriptions of pleasing qualities in the landscape. To elaborate on the poetry of the Romantic period (about 1780-1830) the term "romantic" has all these and other meanings and connotations behind it, which reflects the complexity and multiplicity of the European Romanticism.

Key words: Romantic, civilization, society, particular, century, common, spontaneous, personal

---

**The Characteristics of the Romanticism in Wordsworth****Introduction**

Romanticism is a general, collective term to describe much of the art and literature produced during the late 18th and early 19th centuries. During this period, there was a broad shift of emphasis in the arts, away from the structured, intellectual, reasoned approach of the 18th century (which is often called the 'Age of Reason', or the 'Enlightenment') towards ways of looking at the world which recognized the importance of the emotions and the imagination.

Romanticism can be seen as a revolution in the arts, alongside the political, social and industrial revolutions of the age: all spheres of human activity were undergoing great change.

---

## Chapter-2

# Nature as the Mean of Expression in Romanticism

**DR.N PREMA**

*Associate Professor, Department Of English, PRIST Deemed To Be University, Thanjavur.*

---

### **Abstract:**

The époque of Enlighten was followed by Romanticism. It was the period of extreme changes in the world outlook. This period expressed a strong criticism of the previous one. The principles of writing and the themes had changed. The main hero of the Romantic literature was a lonely man with sensible soul and isolated from the society in terms of his perception of the reality. The period of Romanticism is characterized by its address to nature, in other words, the world was perceived through the nature.

Key words: emotion ,feelings,nature,

### Introduction:

Romanticism was an artistic and intellectual movement that began in Europe in the late 18th century. Romantics believed that nature was a spiritual source of renewal and that people had become spiritually alienated from nature due to the Industrial Revolution and population movement away from the land. They believed that experiencing nature in its purity could provide wisdom and that the solution was to "return to nature".

Romantics' ideas about nature went beyond simply imitating the natural world. They associated nature with mystery, hidden meanings, and sense. They also believed that nature could be a means of expressing emotions and thoughts, and that it could reflect human emotions and explore the relationship between humans and nature. For example, William Wordsworth developed a unique idea of nature that emphasized its role in social life and spiritual redemption.

Romantics' ideas about nature influenced their writing, which is full of reverence for nature. Some examples of Romantic writings that feature nature include:

- John Keats' Ode to a Nightingale



## CHAPTER -3

### Wordsworth Romanticism in "Tintern Abbey"

**DR.N.SUBRAMANIAN,**

*Assistant Professor, Department Of English, PRIST Deemed To Be University, Thanjavur.*

---

#### **Abstract:**

Wordsworth reflects Romanticism through his depiction of nature's beauty and its profound emotional impact. He emphasizes the personal and spiritual connection to the natural world, highlighting themes of memory, tranquility, and the sublime. Wordsworth's introspective and reverent tone underscores the Romantic ideal of finding deeper meaning and inspiration in the natural landscape. "Tintern Abbey" demonstrates a love for nature, of course. Nature is something to study and contemplate and learn from. It can lead one to an experience of the sublime, a feeling of awe and a feeling of oneness with nature; a transcendent experience beyond human reason. Contemplation of nature makes one a better human being.

Key words: love of nature, imagination.

#### **INTRODUCTION:**

"Lines Composed A Few Miles Above Tintern Abbey," by William Wordsworth, is sometimes considered the archetypal Romantic poem for a number of reasons. Essentially, in this poem, Wordsworth is discussing the "aspect most sublime" that is revealed to him by the natural setting of Tintern Abbey, whose beauty has lived in his memory for five years since he was last there. In his *Preface to Lyrical Ballads*, Wordsworth stated that poetry arises from "emotion recollected in tranquility," and we see this at work in this poem, as the poet describes how the "tranquil" beauty of Tintern Abbey gives him strength and inspiration when he is not there. Both of these are tenets of Romantic poetry that show the influence of Edmund Burke's ideas on the sublime which appear in most Romantic works.

The central theme of the poem is typically Wordsworthian: the interactive relationship between the perceiving awareness, "the mind of man," and nature. In the poet's view, perception

## CHAPTER-4

# Symbolism in Romantic Poetry

**DR.E.GEETHA**

*Assistant Professor, Department Of English, PRIST Deemed To Be University, Thanjavur.*

---

### **Abstract:**

This study attempts to investigate the effects of symbolism of birds in British romantic poetry. As a technique symbolism of birds has been used in romantic poetry to enhance poems and give insight to the reader. Birds are also a source of inspiration to romantic poets in order to relate nature with different aspects like feelings and beliefs. In this study, the researcher used the analytical approach and refers to William Wordsworth. In conclusion, Wordsworth symbolism of birds has been used to refer to innocence, gaiety, purity and boyhood, moreover, the researcher found out that use of birds in romantic poetry produces great effects which is accomplished by attaching additional meanings to the poem as it allows the poet to demonstrate the universal concepts underlying more specific circumstances which helps make the poem more relatable to the audience.

**Keywords:** Symbolism of birds, British romantic poetry.

### **INTRODUCTION:**

Symbolism is one of the most effective tools that poets use to communicate expressively and concisely. Todorov (1982: 24) stated that poetic symbols serve to illustrate the meaning of a poem beyond what is explicitly stated, to suggest another meaning rooted in the knowledge shared by a particular culture. In the sense to what Todorov states, poetic symbols evoke images to suggest different levels of meaning. However, not only does the use of symbolism enable the poets communicate the intended message clearly and concisely, but it also permits them let the

## CHAPTER –5

### REALISM NAD ROMANTICISM:SIMILARITIES AND DIFFERENCES

**Dr.R.A. RAJASEKARAN,**

*Associate Professor, Department Of English, PRIST Deemed To Be University, Thanjavur.*

---

#### Abstract:

Realism movements were extremely popular in their time, they were vastly different. Realism sought truth in the ordinary and the tangible, while Romanticism leaned towards the extraordinary, the emotional, and the intangible. The following paper is a comparative study of the artistic movements of Realism and Romanticism in early 19th century Europe. The object is to analyze how each movement affected politics and social hierarchy. The movements are linked to other genres; Romanticism is coupled with Classicism, and Realism is associated with Idealism. The paper explains how both movements faced criticism due to a conservatism of mass taste and a shock of subject matter. Despite the obstacles, the movements prevailed to be considered innovative in context and style. The most compelling arguments found within the current scholarship outlines the opposition that the artists faced from an emerging middle class, and the new and creative forms of methodology employed. The introduction will serve as historical background for the visual composition and political beliefs of the era. The essence of this research is to explain how the movements were a catalyst for social change.

Key Words: Realism,romanticism.

#### INTRODUCTION:

Romanticism and realism they are completely different from each other but somewhere they are related to each other too, because of techniques medium etc but today was I have to count the differences so let's count the differences between romanticism and realism.

Realism expresses a message that depicts situations realistically whereas romanticism illustrates message by using fiction. Romanticism focuses on plot hyperbolic metamorph and feelings. in contrast realism focus is on characters, details, objectivity and separation an artist.

Romanticism rebels against prayer forms of of 8 by picking into feelings belief imagination and fantasy it is a style that takes advantage of personal freedom and spontaneity breaking of the fourth wall between the viewer and the artist so that artist is free to to portray on events within the stories and play reader a little unusual often supernatural characters and forces act in romantic paintings.

**CHAPTER-6****"Tintern Abbey" by William Wordsworth as a Romantic Poem.****MS.R.VISALAKSHI***Assistant Professor, Department Of English, PRIST Deemed To Be University, Thanjavur.***Abstract**

This article describes why the poem "Tintern Abbey" by William Wordsworth is called a romantic poem. The poem was included in the "Lyrical Ballads", a joint production of Wordsworth and Coleridge. The publication is "Lyrical Ballads" is taken by many as the beginning of Romanticism in English Literature. But, the inclusion is not a proof of the poem being called a romantic poem. This article justifies the claim of "Tintern Abbey" as a romantic poem.

Keywords: Tin tern Abbey, Poem

**INTRODUCTION**

The poem "Tintern Abbey" appeared in the "Lyrical Ballads", published jointly by Wordsworth and Coleridge in 1798. The publication of "Lyrical Ballads" is taken as the beginning of romantic periods by many. So the inclusion of "Tintern Abbey" in the "Lyrical Ballads" is a proof of its being a romantic poem. But to just it as a romantic poem, we have to see which characteristics of a romantic poem are found in this poem. The following section will show the characteristics that justify the poem as a romantic one.

Romanticism is a literary concept and it is very difficult to define a literary concept. In spite of this various writers has defined romanticism differently. We can say, it an extraordinary flight of mind and imagination in literary or artistic expression. It marks a strong protest against the distance of classicism. It's sole motto is freedom- freedom from conventions, freedom from every form of restrictions, freedom of mind and imagination etc. We can say a literary piece a romantic one if we find certain characteristics, such as humanism, return to nature, mysticism, interest in the past, subjectivity, escapism, melancholy note etc.

Let's see which characteristics mentioned above are found in the poem "Tintern Abbey"- Jean Jacques Rousseau is called the father of romanticism. Rousseauism is based on two fold

## CHAPTER- 7

**“Kubla khan” as a romantic poem.**

DR.G.KARTHIKA

*Associate Professor, Department Of English, PRIST Deemed To Be University, Thanjavur.***Abstract**

This study includes romantic elements in this poem , I talk about his noble works. Then in the next section I talk about the Romanticism. Samuel Taylor Coleridge's poem Kubla Khan is a Romantic work that explores themes of creativity, nature, and the imagination. Written in 1797, the poem is known for its vivid and enigmatic qualities. It doesn't follow an established form, rhyme scheme, or metrical pattern, and uses literary devices like alliteration, chiasmus, extended metaphor, and personification to create a dreamlike quality. The poem illustrates the remote land cape of Xanadu, with green sunny spots, bright gardens, and blossom-laden trees. The poem's speaker sees that Kubla Khan has created something, but the speaker wishes to create something as well and finds themselves unable to finish. The poem expresses a sense of frustration at the speaker's inability to recapture the inspired state in which they first conceived the poem.

Key words: creativity, nature, imagination.

**Introduction**

Samuel Taylor Coleridge participated in the reformist development animated by French Revolution. He moved with him to Bristol to set up a network, yet the arrangement fizzled In 1795 he wedded the sister of Southey's life partner Sara Fricke, whom he didn't generally adore . Coleridge's assortment sonnets on different subjects was distributed in 1796 and in 1797 showed up sonnets. He shaped a dear companionship with Dorothy and William Wordsworth, one of the most productive inventive connections in English writing. Structure it came about Lyrical

## CHAPTER -8

# Poetic Devices and ; Figurative Languages in P B Shelley.

## *“Ode to the West Wind”*

**MS.K.JAYAPRIYA**

*Assistant Professor, Department Of English, PRIST Deemed To Be University, Thanjavur.*

---

### **Abstract:**

Literary works usually act as a mirror of the society is life. The poem "*Ode to the West Wind*," figures of speech such as personification and simile are prominent. The West Wind is personified as a powerful, almost divine force capable of both destruction and preservation. Similes like "loose clouds like earth's decaying leaves" emphasize the natural cycle of life and death. These devices underscore the poem's themes of transformation and renewal. The West Wind's power and beauty, strong as it is, is at risk by hostile and forces. Shelley views the destructive power of the West Wind as a metaphorical parallel for the beauty of his poetry, which he worries is similarly doomed to oblivion. The writer used the historical approach to understand the historical background of the Romantic Period, and the aspect of the Romanticism era to explore the contain of the poem.

Keywords: Romanticism; imagination; individual; the post; nature.

### **Introduction:**

This paper provides an in-depth analysis of Percy Bysshe Shelley's 1819 poem "*Ode to the West Wind*". It examines the poem's themes of revolution and renewal, its personification of the west wind, and its hybrid form combining elements of the sonnet and terza rima. The analysis also identifies numerous literary devices used in the poem such as metaphor, simile, alliteration, and anastrophe. It discusses the poem's five-stanza structure with three tercets and a couplet in each stanza, as well as Shelley's use of terza rima rhyme scheme and an imperfect eye rhyme in the closing lines.

The wind is first a breath, then a trumpet call, then a spirit, then a voice. It remains invisible and intangible. In revolutionary terms, the wind is evoked as an element that is beyond human control, a symbol of the cycle of nature where every cold winter is inevitably followed by spring, and death and destruction is inevitably followed by new life and renewal.

## CHAPTER-9

# The Imaginative Power Of Keats In “*Ode To A Nightingale*”.

**Dr.D.RAVI KUMAR**

*Assistant Professor, Department Of English, PRIST Deemed To Be University, Thanjavur.*

---

### **Abstract:**

Keats was one of the most famous English Romantic poets of the 19th century. In addition to his poetic achievements, Keats also put forward many aesthetic ideas, and this essay will focus on the concept of "Negative Capability, which requires that the poet should extinguish his inherent consciousness and empty himself, and be comfortable in difficult situations and negative emotions and not be anxious to find answers and reasons, which is the best way to release his imagination.

The "Negative Capability is of Keats's most widely known aesthetic theories, which fully reflects his profound thoughts on truth and beauty and his pursuit of the capacity to be a poet. In order to analyze and deconstruct this concept more specifically, this paper will take *Ode to a Nightingale* as an example and explore the deeper meaning and application of "Negative Capability" while analyzing the poem. This paper concludes that Keats's pursuit of "Negative Capability is perfectly reflected in *Ode to a Nightingale* he lets his imagination go free by emptying himself and uses a lot of rhetorical techniques to show his lament for the fickleness of life and his pursuit of eternal joy. The *ode to the nightingale* is a perfect embodiment of life.

### **Introduction**

John Keats was a highly accomplished English Romantic poet known as the Pleiades, along with Wordsworth, Blake, Byron, and Shelley. In fact, in the 19th century, Keats's talent was not fully appreciated, and his reputation was much less than that of Byron and Shelley. However, by the 20th century, not only did the famous modernist poet T. S. Eliot praise the modern character of Keats's poetry but also the Nobel Prize winner Eugenio Montale ranked Keats among the "Supreme Poets"

Keats mentioned "Negative Capability" in a letter with his brother George. This concept fully demonstrated Keats's almost demanding pursuit of "truth" and "beauty". Negative Capability is not the opposite of "positive" but requires the poet to have the ability to empty himself and accept everything, not to seek the truth of things too much but to see and describe

## CHAPTER-10

### The uses of Romanticism in *The Raven*, a poem by Edgar Allan Poe

MR.M.AMAL RAJ

Assistant Professor, Department Of English, PRIST Deemed To Be University, Thanjavur.

---

Abstract:

"*The Raven*" by Edgar Allan Poe exemplifies Romanticism through its emphasis on emotion, the supernatural, and the exploration of the human psyche. Themes include intense feelings of grief and loss, as well as the haunting presence of the raven, which symbolizes the narrator's descent into madness. The poem's dark, melancholic atmosphere and focus on inner turmoil are hallmark characteristics of Romantic literature.

Key Words: Romanticism,, longing ,separation.

#### Introduction

In "*The Raven*," Edgar Allan Poe uses vivid imagery to create a haunting and melancholic atmosphere. Descriptions of the dark, dreary setting, the ominous raven, and the sorrowful narrator enhance the poem's themes of loss and despair, drawing readers into the narrator's descent into madness.

According to Catherine Belsey, love is 'a condition of happiness that cannot be bought, the one remaining object of a desire that cannot be sure of purchasing fulfilment.' Her criticism implies that love is an indirect experience, something that occurs when one is happy but not something that is intended. Belsey describes desire as 'what is not said, what cannot be said' suggesting that desire stems from a need to verbally express.

Gothic literature depicts love as unattainable despite the strong desire within its characters. Edgar Allan Poe's *The Raven* depicts a speaker who describes feeling 'weak and weary,' an alliterative statement which depicts tiredness and a lack in strength, after 'many a quaint and



## CHAPTER-11

### The Significance of Philosophy in literature

**MR.S.RASAKUMAR**

*Assistant Professor, Department Of English, PRIST Deemed To Be University, Thanjavur*

---

#### Abstract

This paper, examine how philosophical literary fictions convey truths and propositional knowledge. It begins with an examination of the nature of fiction. After discussing different theories of fiction and showing them insufficient, it criticize the prevailing ‘make-believe theories of fiction’, mostly for neglecting certain authorial intentions. The philosophical fictions are, as a part of their design function, intended to convey truths; that the truths are significant and ought to be recognized in order to understand the works properly. It argues that literary works persuade their readers in a distinct, broadly ‘enthymematic’ way. Finally, it shows the concept of the author, the role of her intentions in literary interpretation, and the meaning of literary works.

Key words: knowledge, meaning, criticize

#### INTRODUCTION:

*Philosophy and Literature* has explored the dialogue between literary and philosophical studies. Aspiring to make a significant contribution to the world of humane learning, the journal offers fresh and stimulating ideas in the aesthetics of literature, the theory of criticism, philosophical interpretations of literature, and the literary treatment of philosophy. Reaching beyond the boundaries suggested by its title, the journal also on occasion presents discussions of music, film, and the other arts that further cultural and inter-cultural understanding. *Philosophy and Literature* features a lively assortment of full-length articles, shorter essays, review essays, Symposia (bringing together a set of articles on a particular topic or literary author), In Focus columns (presenting a small set of articles on a precisely-defined issue), and on occasion creative

## CHAPTER-12

### The Transformative Power of the Imagination *Kubla Khan*

**DR. N.MEENURAJATHI**

*Professor, Department Of English, PRIST Deemed To Be University, Thanjavur*

#### ABSTRACT:

Samuel Taylor Coleridge was an English poet, literary critic, philosopher, and theologian who, with his friend William Wordsworth, was a founder of the Romantic Movement in England and a member of the Lake Poets. He also shared volumes and collaborated with Charles Lamb, Robert Southey, and Charles Lloyd. He wrote the poems *The Rime of the Ancient Mariner* and *Kubla Khan*, as well as the major prose work *Biographia Literaria*. His critical work, especially on William Shakespeare, was highly influential, and he helped introduce German idealist philosophy to English-speaking cultures. Coleridge coined many familiar words and phrases, including "suspension of disbelief".

Key words: imagination, unfulfilment.

#### Introduction

Coleridge's poetry is known for its vivid imagery and use of the supernatural, which are both prominent in 'Kubla Khan.' He was also known for his experimentation with form and language, as seen in the complex structure of this poem. Coleridge claims in the preface that he was interrupted while writing, and could therefore not finish the poem as he has planned. It was not until he was encouraged by Lord Byron to do so that Coleridge published the piece. Today, the poem is considered to be one of, if not the, most famous example of Romanticism in the English language.

Or, a vision in a dream. A Fragment.

In Xanadu did Kubla Khan

A stately pleasure-dome decree:

Where Alph, the sacred river, ran

Through caverns measureless to man

Down to a sunless sea.

## CHAPTER-13

### Theme of spontaneous in wordsworth's "*The Tintern Abbey*".

MR.T.THIRUPPATHI

*Assistant Professor, Department Of English, PRIST Deemed To Be University, Thanjavur*

#### **Abstract:**

Spontaneous poetry, also known as "first thought, best thought" poetry, is a writing style that emphasizes the importance of capturing one's initial thoughts and feelings on paper. Wordsworth often uses the term 'spontaneous' to describe natural feelings and emotions that arise without external pressure or force. This suggests a sense of authenticity and naturalness. A darkly funny and spectacularly original exploration of friendship, goodbyes—and spontaneous combustion.

Key words :

Continuity, creativity, emotions

#### **Introduction**

"*Tintern Abbey*" by William Wordsworth is considered as a kind of monologue in verse as Wordsworth confessed that he composed it in his mind while walking through the river Wye. It belongs, along with other 19 poems by this author and four by Samuel Taylor Coleridge, to *Lyrical Ballads*, which is considered to be the inaugural book of the Romantic English Poetry. The main focus of these poems was that of looking for common life situations and depicting them in an unusual manner by means of the power of imagination.

Wordsworth defined poetry as "[...] *the spontaneous overflow of powerful feelings*" and this consists on a breaking up with the 18th century concept of Classicist Canon which looked for poetical perfection. On the contrary, Wordsworth is influenced by the new 19th century ideas of "individualism" and seeks for the use of imagination and true feelings, not being so worried about poetical structural conventions. That is the reason why he writes in blank verse. Therefore, he takes advantage of his emotions in given moments of inspiration just like he did during his

## CHAPTER-14

### EDGAR ALLAN POE AS AN AMERICAN ROMANTICISM WRITER

MR.P.KINGSLEY PREM

*Assistant Professor, Department Of English, PRIST Deemed To Be University, Thanjavur*

#### **Abstract:**

Edgar Allan Poe's stature as a major figure in world literature is primarily based on his ingenious and profound short stories, poems, and critical theories, which established a highly influential rationale for the short form in both poetry and fiction. Regarded in literary histories and handbooks as the architect of the modern short story, Poe was also the principal forerunner of the "art for art's sake" movement in 19th-century European literature. Whereas earlier critics predominantly concerned themselves with moral or ideological generalities, Poe focused his criticism on the specifics of style and construction that contributed to a work's effectiveness or failure. In his own work, he demonstrated a brilliant command of language and technique as well as an inspired and original imagination. Poe's poetry and short stories greatly influenced the French Symbolists of the late 19th century, who in turn altered the direction of modern literature.

Key Words: History ,Biography, Literary Works

#### **Introduction**

Few writers exist outside of the currents of the times in which they live, and Poe is no exception. He is clearly a product of his time, which in terms of literature, is called the Romantic era. The Romantic movement was one which began in Germany, moved through all of Europe and Russia, and, almost simultaneously, changed the entire course of American literature. Among England's great Romantic writers are William Wordsworth, Samuel Taylor Coleridge, John Keats, Lord Byron, Percy Shelley, and Sir Walter Scott. Romantic writers in America who were contemporaries of Poe include Hawthorne (whose works Poe reviewed and admired),

## CHAPTER-15

### Imagination and creativity in wordsworth's "*The Tintern Abbey*"

MS.M.THAMIZHMANI

*Assistant Professor, Department Of English, PRIST Deemed To Be University, Thanjavur*

#### Abstract:

Wordsworth saw imagination as a powerful, active force that works alongside our senses, interpreting the way we view the world and influencing how we react to events. He believed that a strong imaginative life is essential for our well-being. Often in Wordsworth's poetry, his intense imaginative effort translates into the great visionary moments of his work.

Key words: creativity ,imagination.

#### Introduction

This paper portrayed the visual imagination about nature and circumstantial surroundings . This idea of a presence in the mind of man that permeates all experience is, in Wordsworth's own words, his concept of imagination. Wordsworth first visited Tintern Abbey and the Wye valley, which gave him inspiration to write this celebrated poem at the age of twenty eight, he was highly influenced by the beautiful and splendid atmosphere. He revisited the same place five years later along with his sister, Dorothy, and this time he realized not only its natural beauty, but also its grandeur. This distant place away from urban life both gives him pleasure, and leads him to remember his childhood years.

His re-realization of nature results in his self-awareness. In that way, by comparing the two visits, the poet underlines his transformation from youth into maturity to compare and contrast his feelings and perceptions in each visit. Wordsworth reflects the impact and the healing power of nature on his mind for it contributes to his spiritual development. Kamrunnessa Khatun indicates, "In every line of the poem, he personifies the natural objects as if lost in profound thought he perceives one-to-one correspondence between man and nature."

In the opening stanza, the repetition of the length of time that Wordsworth was away from the Wye valley for five years saying, "Five summers, with the length of five long winters!," suggests that being away from this beautiful and natural scene for so long was a burden on the poet. He is there again with a fresh vision to evaluate all the natural beauties he remembers from his first visit. His admiration towards the glory of nature is described as "Do I behold these steep



# MARUTHAM

EDITED BY  
**K.KALIYAMOORTHY**



978-93-6255-198-6

நூல் : மருதம்

பதிப்பாசிரியர் : திரு. ச.கலியமூர்த்தி

மொழி : தமிழ்

பதிப்பு : 2018

பதிப்பகம் : தமிழாய்வுத்துறை

பொன்னையா இராம ஜெயம் நிகர்நிலைப்

பல்கலைக்கழகம் .வல்லம், தஞ்சாவூர்-613 403

## பொருளடக்கம்

- |  |      |
|--|------|
| 1. திணைகள்                                       | -04  |
| முனைவர்..மு.மலர்க்கொடி                           |      |
| 2. சங்க காலத்தில் வேளாண்மைப்பண்பாடு              | -13  |
| முனைவர். க அறிவுக்கனி                            |      |
| 3. மருதத் திணையின் இயல்புகள்                     | -18  |
| Mr. D. திருமுருகன்                               |      |
| 4. பத்துப்பாட்டில் பண்பாட்டுக் கூறுகள்: உணவுமுறை | -23  |
| முனைவர். சே சுகந்தி                              |      |
| 5 .சங்க இலக்கியத்தில் வாயில் மறுத்தல்            | - 33 |
| முனைவர். சு அழகிரிசாமி                           |      |
| 6 .அக இலக்கியத்தின் நிகழ்வுகள்                   | -38  |
| Mrs.க வீணை முத்து                                |      |
| 7. முல்லைப்பாட்டு                                | -43  |
| Mrs. க காள்ஸ்வரி                                 |      |



## திணைகள்

முனைவர்.மு.மலர்க்கொடி

இணைப்பேராசிரியர்தமிழ்த் துறை ,

பொன்னையா ராமஜெயம் நிகர் நிலை

பல்கலைக்கழகம், வல்லம், தஞ்சாவூர்

அகத்திணை

ஐந்து வகை நிலம் – (ஐவகை நிலம், ஐந்திணை) அகத்திணை

அகத்திணை என்பது அக வாழ்வு. ஆணும் பெண்ணும் காதல் கொண்ட இல்லற வாழ்வை உள்ளடக்கியது அகத்திணை ஆகும்.தொல்காப்பியம் இம்மூன்று பொருள்களின் விளக்கங்களையும் உட்கூறுகளையும் அதன் பொருளதிகாரத்தில் விவரித்துள்ளது.

தொல்காப்பியம் அகத்திணையை ஏழு பிரிவுகளாக வகுத்துள்ளது.

கைக்கிளை

குறிஞ்சித் திணை

பாலைத் திணை

முல்லைத் திணை

மருதத் திணை

நெய்தல் திணை

பெருந்திணை

முப்பொருள்

அகத்திணையில் இடம்பெறும் மூன்று வகையான பொருட்களான முதற்பொருள், கருப்பொருள், உரிப்பொருள் என்பவை முப்பொருள் என்று அழைக்கப்படுகின்றன.

முதற்பொருள்

## சங்க காலத்தில் வேளாண்மைப்பண்பாடு

முனைவர். க அறிவுக்கனி,  
உதவிப்பேராசிரியர் , தமிழ்த் துறை ,  
பொன்னையா ராமஜெயம் நிகர் நிலை  
பல்கலைக்கழகம், வல்லம், தஞ்சாவூர்

### முன்னுரை:

சங்க இலக்கியங்கள் பழந்தமிழர்களின் வாழ்க்கை பண்பாட்டை விளக்குவதாக அமைந்துள்ளன. சங்க காலத்தில் வேளாண்மைப்பண்பாடு மிகவும் முக்கியத்துவம் வாய்ந்ததாக உள்ளன. வேளாண்மை சமூக மாற்றத்திற்கான அடிகோலாய் தோன்றின எனலாம். சங்கச் சமுதாயம் இனக்குழு வாழ்விலிருந்து அரசு உருவாக்கத்திற்கும், நகரமயமாதலுக்கும் அடிப்படையாய் அமைந்தன. இவ்வேளாண்மைப்பண்பாட்டை பற்றிக் காண்பதாக இக்கட்டுரை அமைகிறது.

### பண்பாடு

பண்பாடு எனும் சொல்லுக்கு ஆங்கிலத்தில் 'உரடவரசந' என்று கூறுவர். பண்பாடு எனும் சொல் 'பண்படு' என்னும் சொல்லிலிருந்து உருவாக்கப்பட்டது எனலாம். நல்ல பழக்க வழக்க வழக்கங்களை மேற்கொள்ளும் மனிதனைப் பண்பட்ட மனிதன் எனலாம். பண்பட்ட உள்ளம் கொண்டவரைப் பண்பாட்டைப் பின்பற்றுவர்கள் எனலாம். பண்பாடு எனும் சொல்லிற்கு 'செம்மைப்படுத்தல்' என்னும் பொருளும் இச்சொல்லுக்கு அமையப்பெற்றுள்ளதை அறியலாம். 'பண்பாடு என்பது எண்ணற்ற கூறுகளால் இணைக்கப்பெற்ற ஒழுங்கமைப்பு ஆகும். கற்றுணர்ந்து பகிர்ந்து கொள்ளப்படும் நடத்தை முறைகளின் தொகுப்பே பண்பாடு என மானிடவியலாளர் கூறுவர். மேலும், சீர்படுதல், பண்ணுதல் என்ற பொருளும் பண்பாட்டிற்கு வழங்கப்படுகிறது.

### மருத நில ஊர்கள்

மருத நில ஊர்கள் மருத நில வேளாண்மை பண்பாட்டை வெளிப்படுத்தும் வகையில் காட்டு நிலத்திற்கும், கடலோர நிலத்திற்கும் இடைப்பட்ட நீர் வளமிக்க ஆற்றுப்படுகையில் அமைந்த ஊர்களை மருத நில ஊர்கள் என அழைக்கப்படுகிறது. இப்பகுதியில் மருத மரங்கள் மிகுதியாகக் காணப்படுகின்றன. இந்நிலப்பகுதி பல்வேறு பயிர் வகைகளை வேளாண்மை செய்ய ஏற்ற நிலவளமும் நீர் வளமும் கொண்ட பகுதியாக உள்ளன. மருத நில

## மருதத் திணையின் இயல்புகள்

Mr. D. திருமுருகன்

உதவிப்பேராசிரியர் , தமிழ்த் துறை ,  
பொன்னையா ராமஜெயம் நிகர் நிலை  
பல்கலைக்கழகம், வல்லம், தஞ்சாவூர்

பரத்தை ஒழுக்கம், அது தொடர்பான வாயில் மறுத்தல், புதுப்புனல் ஆடல், ஊடல் தணிவித்தல் போன்றவையும் பிள்ளைத்தாலி அணிதல் போன்ற சமூக நிகழ்ச்சிகளும் மருதத் திணைப் பாடல்களில் காணக் கிடைக்கின்றன.

பரத்தைமை ஒழுக்கம்

மருதத் தலைவன் கற்பு வாழ்க்கையில் மனைவியை விடுத்துப் பரத்தையுடன் சில நாள் தங்கி மகிழ்வான். இத்தகு பரத்தைமை ஒழுக்கத்தை வெறுத்து ஊடல் கொள்வாள் தலைவி. மருதத் திணைப் பாடல்களில் பரத்தைமை ஒழுக்கம் பெரிதும் குறிக்கப்படுகிறது. மருதத் திணைக்குரிய உரிப்பொருள் ஊடலும் ஊடல் நிமித்தமும் என்பதை அறிவீர்கள். தலைவியின் ஊடலுக்குத் தலைவனின் பரத்தைமை ஒழுக்கமே காரணமாகச் சொல்லப்படுவதால், மிகப் பெரும்பாலான மருதத் திணைப் பாடல்களில் தலைவனின் பரத்தைமை ஒழுக்கமே உள்ளடக்கம் ஆகிறது.

தலைவன் தன் இல்லத்துக்குச் செல்ல மறந்து பரத்தையோடு தங்குகிறான். ஒருநாள் பரத்தை “நின் இல்லத்திற்குச் சென்று வா” என்று கூறுகிறாள். தன் இல்லம் நாடி வருகிறான் தலைவன், “பரத்தை விரும்பிச் சொன்னதால் நீ இங்கு வர வேண்டாம் அவளது வீட்டிலேயே தங்கிவிடு. அது எமக்கும் நல்லது” என்று தலைவனிடம் கூறுகிறாள் தோழி.

*நினக்கே அன்றுஅஃது எமக்குமார் இனிதே*

*நின்மார்பு நயந்த நன்னுதல் அரிவை*

*வேண்டிய குறிப்பினை ஆகி*

## பத்துப்பாட்டில் பண்பாட்டுக் கூறுகள்: உணவுமுறை

முனைவர். சே சுகந்தி

உதவிப்பேராசிரியர் , தமிழ்த் துறை ,  
பொன்னையா ராமஜெயம் நிகர் நிலை  
பல்கலைக்கழகம், வல்லம், தஞ்சாவூர்

பண்பாடு என்பது தொடர்ந்து கற்பது. அதனை அனைவருடனும் பகிர்ந்து கொள்வது. ஒரு தலைமுறையில் கற்றவற்றைப் பின்வரும் தலைமுறையினர் பெற்றுக் கொண்டு அவர்கள்தம் தலைமுறையில் மேலும் புதியனவற்றைக் கற்கின்றனர். இதனால் பண்பாடு தொடர்ச்சியான மாற்றத்திற்கு உட்படுகிறது.

பண்பாடு என்பது தொடர்ந்து கற்பது. அதனை அனைவருடனும் பகிர்ந்து கொள்வது. ஒரு தலைமுறையில் கற்றவற்றைப் பின்வரும் தலைமுறையினர் பெற்றுக் கொண்டு அவர்கள்தம் தலைமுறையில் மேலும் புதியனவற்றைக் கற்கின்றனர். இதனால் பண்பாடு தொடர்ச்சியான மாற்றத்திற்கு உட்படுகிறது.

சமூக இயல் அறிஞர்களின் கருத்தின்படி, பண்பாடு என்பது, வாழ்க்கை முறை (way of life) என்பதாகும். ஒவ்வொரு மனித சமுதாயத்திற்கும் ஒரு பண்பாடு உண்டு. ஒரு சமுதாயத்தில் வாழுகின்ற பெரும்பான்மை மக்களின் ஒருமித்த நடத்தைகளையும் எண்ணங்களையும் அது வெளிப்படுத்தும். ஒரு சமுதாயத்தில் அமைந்துள்ள கலை, நம்பிக்கை, பழக்கவழக்கங்கள், மொழி, இலக்கியம், விழுமியங்கள் (values) முதலியன அந்தச் சமுதாயத்தின் பண்பாட்டுக் கூறுகள் எனப்படும்.

தமிழ் கலாச்சாரம், தமிழ் மக்களின் பண்பாடு ஆகும். தமிழ் கலாச்சாரம் மொழி, இலக்கியம், இசை, நடனம், நாட்டுப்புற கலை, தற்காப்பு கலை, ஓவியம், சிற்பம், கட்டிடக்கலை, விளையாட்டு, ஊடகங்கள், நகைச்சுவை, உணவு, ஆடைகள், கொண்டாட்டங்கள், தத்துவம், மதங்கள், மரபுகள், சடங்குகள், நிறுவனங்கள் ஆகியவற்றில் வெளிப்படுத்தப்படுகின்றது. இத்தொடர்பில்,

## சங்க இலக்கியத்தில் வாயில் மறுத்தல்

முனைவர். சு அழகிரிசாமி

உதவிப்பேராசிரியர் , தமிழ்த் துறை ,  
பொன்னையா ராமஜெயம் நிகர் நிலை  
பல்கலைக்கழகம், வல்லம், தஞ்சாவூர்

முன்னுரை

சங்கப் புலவர்கள் தமது பாடல்களை சமுதாய நோக்கில் பாடிச் சென்றனர். பின்னர் அகம், புறம் என வகைப்படுத்தி, திணை, துறை மரபுக்குள்ளாகப் பாடல்கள் தொகுக்கப்பட்டுள்ளன. அவற்றுள் மருதத்திணையில் உள்ள "வாயில் மறுத்தல்" என்னும் துறை ஆய்வுக்குரிய பொருளாகும்.

சங்க இலக்கியத்தில் வாயில் மறுத்தல்

- வாயில் மறுத்தல் - விளக்கம்
- வாயில் மறுத்தல் - பாடல்கள்
- வாயில் - இலக்கணம்
- வாயில் மறுக்கும் சூழல்
- வாயில் மறுத்தலில் தோழி
- தலைவனின் கொடுமை கூறல்
- தலைவியின் இல்லற மாண்பு
- வாயில் மறுத்தலுக்கான காரணங்கள்

வாயில் மறுத்தல் - விளக்கம்

மருதத்திணையில்; ஊடலும் ஊடல் நிமித்தமும் உரிப்பொருளாக அமைகிறது. அதனுள் ஊடலுக்குக் காரணமாகப் பரத்தமை ஒழுக்கம் கூறப்பட்டுள்ளது. அவ்வாறு பரத்தமையை நாடிச் செல்லும் தலைவனைத் தோழி மூலமாக வாயில் மறுக்கின்றாள் தலைவி. களவு வாழ்க்கையின் போது பல அன்பான இனிய சொல்லைக் கூறித் தலைவியின் அன்பைப் பெற்றவன் கற்பு வாழ்க்கை தொடங்கிய சில நாட்களிலேயே பரத்தையை நாடிச் செல்கிறான்.

## அக இலக்கியத்தின் நிகழ்வுகள்

Mrs.க வீணை முத்து

உதவிப்பேராசிரியர் , தமிழ்த் துறை ,  
பொன்னையா ராமஜெயம் நிகர் நிலை  
பல்கலைக்கழகம், வல்லம், தஞ்சாவூர்

**இயற்கைப் புணர்ச்சி** – தலைவன் வேட்டையாடச் செல்லும்பொழுது தலைவியைக் காண்கின்றான். தலைவியின் மீதுகாதல்கொள்கின்றான். தலைவியும் அவன் மீது காதல் கொள்கின்றாள். இருவரும் அன்பால் புணர்ச்சி மேற்கொள்வார்கள். **இடந்தலைப்பாடு** (இடத்தை அடைதல்) – இயற்கைப் புணர்ச்சியின்பின் தலைவன் முன்னர்த்தான் தலைவியைக் கண்ட இடத்தை அடைந்து அவளுடன் கூடி மகிழ்தல்.

**பாங்கற் கூட்டம்** (தோழனால் ஏற்பட்ட சந்திப்பு) – காதல் கொண்ட தலைவன் தலைவியை இடையிடையே பிரிய நேர்ந்தால், மனம் தளர்ந்து உடல் மெலிந்து வருந்துவான். அவனுடைய பாங்கன் (தோழன்) அவனை இடித்துரைத்து, தலைவியுடன் அவன் கூடுவதற்கு உதவுவான்.

**பாங்கியர் கூட்டம்** (தோழியால் ஏற்பட்ட சந்திப்பு) – தலைவியைச் சந்திக்க முடியாத சூழ்நிலையில் தலைவன் தோழியின் உதவியை நாடுவான். அவள் தலைவனும் தலைவியும் சந்திக்க உதவுவது தான் பாங்கியர் கூட்டம்.

**இரவுக்குறி** – இரவுக்குறி என்பது இரவு நேரத்தில் ஒரு குறித்த இடத்தில் தலைவன், தலைவியைத் தோழியின் உதவியுடன் சந்திப்பதாகும்.

**பகற்குறி** – தலைவன் தோழியின் உதவியோடு மீண்டும் மீண்டும் தலைவியைப் பகற்பொழுதில் ஒரு குறித்த இடத்தில் சந்திப்பது பகற்குறி ஆகும். பகலில் வந்து செல்வதால் ஏற்படும் இடையூறுகளையும் இரவில் சந்திப்பதால் ஏற்படும் நன்மைகளையும் கருத்தில் கொண்டு தோழி பகற்குறியை மறுத்து இரவுக்குறியை சில வேளைகளில் விரும்புவது உண்டு.

முல்லைப்பாட்டு

Mrs. க காளீஸ்வரி

உதவிப்பேராசிரியர் , தமிழ்த் துறை ,

பொன்னையா ராமஜெயம் நிகர் நிலை

பல்கலைக்கழகம், வல்லம், தஞ்சாவூர்

பாட்டும் புலவரும்

ஏறத்தாழ இரண்டாயிரம் ஆண்டுகளுக்குமுன் பல புலவர்களால்

இயற்றப்பட்ட பல பாடல்களின் தொகுப்பாகிய எட்டு நூல்கள்

எட்டுத்தொகை என்றும் பத்து நீண்ட பாடல்கள் பத்துப்பாட்டு என்றும்

அழைக்கப்படுகின்றன. பத்துப்பாட்டில் உள்ள பாடல்களில்

முல்லைப்பாட்டும் ஒன்று. அது 103 அடிகளைக்கொண்ட சிறிய

பாடல். இப்பாடல் ஆசிரியப்பா வகையைச் சார்ந்தது. முல்லைப்பாட்டை

இயற்றிய புலவரின் பெயர் காவிரிப்பூம்பட்டினத்துப் பொன் வாணிகனார்

மகனார் நப்பூதனார். இவருடைய இயற்பெயர் பூதன். இவருடைய

பெயருக்கு முன் சிறப்புப் பொருளைத்தரும் "ந" என்னும்

எழுத்தையும், பெயருக்குப்பின், உயர்வைக் குறிக்கும் "

" விசுவதியையும் சேர்த்து இவர் நப்பூதனார் என்று அழைக்கப்பட்டார். நக்கீரன

ார், நக்கண்ணையார், நத்தத்தனார், காக்கை பாடினியார் நச்செள்ளையா

ர் முதலிய பெயர்களில் "ந" என்னும் சிறப்பு





# **SANGA ILAKKIYAM**

*Edited By*

**DR.K.MANOKARAN**



978-93-6255-128-7



நூல் சங்க இலக்கியம் -

பதிப்பாசிரியர் முனைவர் Dr.K.மனோகரன்

மொழி - தமிழ்

பதிப்பு -2018

பதிப்பகம் : தமிழாய்வுத்துறை

பொன்னையா இராம ஜெயம் நிகர்நிலைப்

பல்கலைக்கழகம் .வல்லம், தஞ்சாவூர்-613 403

பொருளடக்கம்

1. தமிழர் வீரம் -01  
Mrs K.காளீஸ்வரி
2. சங்க இலக்கியங்களின் சிறப்புகள், -13  
முனைவர் க.அறிவுக்கனி
3. சங்க இலக்கிய உவமை -17  
முனைவர் சே.சுகந்தி
4. தியாகத்தின் சிறப்பு வீரம் -35  
முனைவர் மு.மலர்க்கொடி
5. வீர விளையாட்டு -41  
திருமதி K. வீணைமுத்து
6. காவியமும் ஓவியமும் - 46  
முனைவர் ச.சதீஸ்வரன்
7. பண்டைய போர் முறைகளும், மரபுகளும் - 54  
Mrs. D. திருமுருகன்

## 1. தமிழர் வீரம்

Mrs K.காளீஸ்வரி

உதவிப்பேராசிரியர் , தமிழ்த் துறை ,

பொன்னையா ராமஜெயம் நிகர் நிலை

பல்கலைக்கழகம், வல்லம், தஞ்சாவூர்

உலகின் மூத்த மொழிகளுள் ஒன்றாக விளங்குகின்ற மொழி தமிழ் மொழியாகும். 'கல் தோன்றி மண் தோன்றாக் காலத்தே வாளொடு முன்தோன்றி மூத்தகுடி' என்று புறப்பொருள் வெண்பா மாலை என்ற புற இலக்கண நூல் கூறுவதைக் கொண்டு தமிழின் பழமையை உணரலாம். தொடக்க காலத்தில் தமிழ் எந்தப் பகுதியில் பேசப்பட்டது என்பதைத் தொல்காப்பியம் என்ற பழம்பெரும் இலக்கணநூல் கூறுகிறது. தொல்காப்பியத்திற்குப் பாயிரம் எழுதிய பனம்பாரனார் என்பவர்

*வடவேங்கடம் தென்குமரி ஆயிடைத்*

*தமிழ்கூறும் நல்லுலகம்*

என்று தமிழ்நாட்டின் எல்லையைக் கூறுகின்றார். எனவே, வடக்கே வேங்கடமலை முதல் தெற்கே குமரிமுனை வரை தமிழ் பேசப்பட்டதாக நாம் இதன் மூலம் அறிகிறோம். தமிழ்நாட்டைச் சேர, சோழ, பாண்டியர் என்ற மூவேந்தர்களும், பல குறுநில மன்னர்களும் ஆண்டதாகச் சங்க இலக்கியங்கள் கூறுகின்றன. சேர நாட்டிற்கு வஞ்சி மாநகரும், சோழ நாட்டிற்குப் பூம்புகாரும், பாண்டிய நாட்டிற்கு மதுரையும் தலைநகர்களாக இருந்துள்ளன. மூவேந்தர்களில் பாண்டிய மன்னர்கள் தமிழ்மொழியைப் போற்றி வளர்க்கும் வண்ணம் தமிழ்ச் சங்கங்கள் வைத்து நடத்தியதாகப் பல்வேறு சான்றுகள் கிடைக்கின்றன.

அச்சங்கங்களில் தமிழ்ப் புலவர்கள் இருந்து தமிழ் ஆய்வு செய்ததாகவும், தமிழில் பல்வேறு செய்யுள்களை இயற்றியதாகவும் சங்க இலக்கியங்கள், இறையனார் களவியல் உரை போன்ற நூல்களால் அறியலாம். தமிழ் என்ற சொல் இனிமை என்ற பொருளை உடையது. இனிமையும், நீர்மையும் தமிழ் எனலாகும்' என்று பிங்கல நிகண்டு

## 2. சங்க இலக்கியங்களின் சிறப்புகள்,

முனைவர் க.அறிவுக்கனி

உதவிப்பேராசிரியர் , தமிழ்த் துறை ,

பொன்னையா ராமஜெயம் நிகர் நிலை

பல்கலைக்கழகம், வல்லம், தஞ்சாவூர்

சங்க இலக்கியங்கள் உவமைகளால் சிறப்புற்ற இலக்கியங்களாகும். சங்க காலத்தில் தோன்றிய இலக்கண நூலாகிய தொல்காப்பியத்தில் உவமைக்காகவே ஓர் இயல் உண்டு. அது உவம இயல் எனப்படும். சங்க அக இலக்கியங்களிலும், புற இலக்கியங்களிலும் பெரும்பாலான பாடல்கள் உவமைகளோடு மட்டுமே விளங்குகின்றன. எளிய உவமைகளால் மிகச் சிறந்த பொருளை விளங்க வைப்பது சங்க இலக்கியங்களின் சிறப்பியல்புகளுள் ஒன்று. சோழன் போர்வைக் கோப்பெரு நற்கிள்ளி போர்க்களத்தில் விரைவாக வாளைச் சுழற்றிப் போரிடுகிறான். அவன் போர்க்களத்தில் எவ்வாறு வாளைச் சுழற்றுவான் என்பதற்குச் சாத்தந்தையார் என்ற புலவர்,

*சாறுதலைக் கொண்டெனப் பெண்ணீற்று உற்றெனப்*

*பட்ட மாரி ஞான்ற ஞாயிற்றுக்*

*கட்டில் நிணக்கும் இழிசினன் கையது*

*போழ்தூண்டு ஊசியின் விரைந்தன்று மாதோ*

- (புறம், 82)

என்று உவமை கூறுகிறார். அதாவது ஊரிலே விழா நடைபெற உள்ளது. அவ்விழாவிற்கு உதவப் போக வேண்டும்; மனைவிக்குப் பிள்ளைப்பேறு மழை பெய்து கொண்டிருக்கிறது. பிறக்கும் குழந்தையைத் தரையில் போடமுடியாது. அதற்காகக் கட்டில் பின்னுகின்றான் ஓர் ஏழைத் தொழிலாளி. இவ்வளவு செயல்களையும் ஒருசேரச்

### 3. சங்க இலக்கிய உவமை

முனைவர் சே.சுகந்தி ,

இணைப்பேராசிரியர்தமிழ்த் துறை ,

பொன்னையா ராமஜெயம் நிகர் நிலை

பல்கலைக்கழகம், வல்லம், தஞ்சாவூர்

சங்க இலக்கியங்கள் உவமைகளால் சிறப்புற்ற இலக்கியங்களாகும். சங்க காலத்தில் தோன்றிய இலக்கண நூலாகிய தொல்காப்பியத்தில் உவமைக்காகவே ஓர் இயல் உண்டு. அது உவம இயல் எனப்படும். சங்க அக இலக்கியங்களிலும், புற இலக்கியங்களிலும் பெரும்பாலான பாடல்கள் உவமைகளோடு மட்டுமே விளங்குகின்றன. எளிய உவமைகளால் மிகச் சிறந்த பொருளை விளங்க வைப்பது சங்க இலக்கியங்களின் சிறப்பியல்புகளுள் ஒன்று. சோழன் போர்வைக் கோப்பெரு நற்கிள்ளி போர்க்களத்தில் விரைவாக வாளைச் சுழற்றிப் போரிடுகிறான். அவன் போர்க்களத்தில் எவ்வாறு வாளைச் சுழற்றுவான் என்பதற்குச் சாத்தந்தையார் என்ற புலவர்,

*சாறுதலைக் கொண்டெனப் பெண்ணீற்று உற்றெனப்*

*பட்ட மாரி ஞான்ற ஞாயிற்றுக்*

*கட்டில் நிணக்கும் இழிசினன் கையது*

*போழ்தூண்டு ஊசியின் விரைந்தன்று மாதோ*

- (புறம், 82)

என்று உவமை கூறுகிறார். அதாவது ஊரிலே விழா நடைபெற உள்ளது. அவ்விழாவிற்கு உதவப் போக வேண்டும்; மனைவிக்குப் பிள்ளைப்பேறு மழை பெய்து கொண்டிருக்கிறது. பிறக்கும் குழந்தையைத் தரையில் போடமுடியாது. அதற்காகக் கட்டில் பின்னுகின்றான் ஓர் ஏழைத் தொழிலாளி. இவ்வளவு செயல்களையும் ஒருசேரச்

#### 4. தியாகத்தின் சிறப்பு வீரம்

முனைவர் மு.மலர்க்கொடி

இணைப்பேராசிரியர்தமிழ்த் துறை ,

பொன்னையா ராமஜெயம் நிகர் நிலை

பல்கலைக்கழகம், வல்லம், தஞ்சாவூர்

பிறர்பொருட்டு ஒருவன் தன்னலம் இழக்கும் தகைமையே தியாகம் ஆகும். தமிழகத்தில் என்றும் தியாகத்துக்குத் தனிப் பெருமையுண்டு. "தமக்கென வாழாப் பிறர்க்குரியாளர்" என்று அத்தகையாரைத் தமிழ்நாடு போற்றுகின்றது. அன்னார் இருத்தலாலே இவ் வுலகம் உள்ளது என்று பாடினான் ஒரு பாண்டியன்.

#### குமணனும் இளங்குமணனும்

கொங்குநாட்டின் பெருமையெல்லாம் தன் பெருமை யாக்கிக்கொண்டான் ஒரு கொடைவீரன். அவன் முதிரம் என்னும் மலையை ஆண்ட குறுநில மன்னன். குமணன் என்னும் பெயருடைய அக் கோமகன், இரப்போர்க்கு இல்லை யென்று உரைக்கலாற்றாத இதயம் வாய்ந்தவன். அவனைத் தமிழகம் பாட்டாலும் உரையாலும் பாராட்டி மகிழ்ந்தது. அதனை அறிந்தான் அவன் தம்பியாகிய இளங்குமணன். அழுக்காறு அவன் மனத்தை அறுத்தது; 'முன்னையோர் ஈட்டி வைத்த பணமும், முதிரமலையின் வளமும் கொள்ளை போகின்றனவே' என்று அவன் குமுறினான்; தமையனைக் கொல்வதற்குச் சூழ்ச்சி செய்யத் தொடங்கினான்.

#### அரசு துறந்த குமணன்

தம்பியின் வஞ்ச மனத்தை அறிந்தான் குமணன். தன்னுயிரை அவன் பெரிதாகக் கருதவில்லை; தம்பி நினைப்பதை முடிப்பானாயின் பாவமும் பழியும் வந்து அவனைப்

## 5.வீர விளையாட்டு

திருமதி K. வீணைமுத்து

உதவிப்பேராசிரியர் , தமிழ்த் துறை ,

பொன்னையா ராமஜெயம் நிகர் நிலை

பல்கலைக்கழகம், வல்லம், தஞ்சாவூர்

வீர விளையாட்டில் என்றும் விருப்பமுடையவர் தமிழர். வேட்டையாடல், மல்லாடல், ஏறுதழுவுதல் முதலிய விளையாட்டங்கள் மிகப் பழமை வாய்ந்தனவாகும். வேட்டையைத் தொழிலாகக் கொண்டவர் வேடர் என்றும், வேட்டுவர் என்றும் பெயர் பெற்றனர். மற்றும் வில்லாளராகிய பெருநில மன்னரும், குறுநில மன்னரும் பொழுதுபோக்காக வேட்டையாடினர். காவிரிக் கரையிலும், பாலாற்றங் கரையிலும் பரந்து நின்ற காடுகளில் வேட்டையாடப் புறப்பட்ட சோழமன்னன் கோலத்தைக் கலிங்கத்துப் பரணியிலே காணலாம். மல்லாட்டத்தில் வல்லவர் மல்லர் எனப்படுவர். அன்னார் முற்காலத்து மன்னரால் மதிக்கப்பெற்றனர். முல்லைநில மாந்தராகிய ஆயர், ஏறு தழுவும் விளையாட்டிற் சிறந்து விளங்கினர். இன்றும் தமிழ் நாட்டிற் சில பாகங்களில் சல்லிக்கட்டு என்னும் பெயரால் இவ் விளையாட்டு நடைபெறுகின்றது.

### வேட்டையாடல்

தமிழ் நாட்டு மலைகளிலும் காடுகளிலும் பல வகையான விலங்குகள் உண்டு. அவற்றுள் உருவிலும் திருவிலும் உயர்ந்தது யானை. வீரம் உடையது வேங்கை. கடுமை வாய்ந்தது கரடி. கொழுமை சான்றது பன்றி. இவை பகற் பொழுதில் மரமடர்ந்த தூறுகளிலும் மலைக்குகை களிலும் மறைந்து வாழும்.

### வேட்டை நெறி

வேட்டையாடச் செல்பவர் வாய்ப்பான இடங்களில் திண்ணிய கயிறு வலைகளைக் கட்டுவர்; மோப்பம் பிடிக்கும் வேட்டை நாய்களைக் கட்டவிழ்த்து விடுவர்; பறையறைந்து காட்டைக் கலைப்பர். அப்போது விலங்குகள் விழுந்தடித்து ஓடும். அவ்விதம் கலைந்தோடும் உயிர்களைக் கண்டபடி கொல்வதில்லை பண்டை வேடர். வேட்டை

## 6. காவியமும் ஓவியமும்

முனைவர் சு.சதீஸ்வரன்

உதவிப்பேராசிரியர் , தமிழ்த் துறை ,

பொன்னையா ராமஜெயம் நிகர் நிலை

பல்கலைக்கழகம், வல்லம், தஞ்சாவூர்

நாலு திசையிலும் ஒரே பசுமை; மழைக் காலத்தில் காடு முழுவதும் தளிரும் பூவும் குலங்குகின்றன. அடர்த்தியான அந்தக் காட்டினிடையே மெல்லச் செல்கிறது தேர். தேருக்குள்ளே ஆணில் அழகன், வீரர்க்குள் வீரன் ஒருவன் உட்கார்ந்து கொண்டிருக்கிறான். தான் மேற்கொண்ட காரியத்தில் வெற்றியடைந்த மிடுக்கை அவனுடைய எடுப்பான பார்வை எடுத்துரைக்கிறது. இயற்கை யெழிலை இறைவன் வஞ்சகமின்றி வாரி இறைத்திருக்கும் வனத்தைப் பார்க்கிறான். எத்தனை அழகு ததும்புகிறது! தேருக்குப் பின்னே ஒரு கூட்டம் வருகிறது. வில்லும் கையுமாக வரும் வீரர் கூட்டம் அது. ஆனால் அவர்கள்தேரில் இருப்பவன் திடீரென்று தன் சாரதியைப் பார்த்து, "வலவ, குதிரையை வேகமாக ஓட்டு. எவ்வளவு வேகமாக ஓட்ட முடியுமோ அவ்வளவு வேகமாக ஓட்ட வேண்டும். உன் கைத்திறமையை இன்று தான் பார்க்கப் போகிறேன்" என்று கட்டளையிடுகிறான்.

தேர்ப்பாகனுக்கு இந்த அவசரத்துக்குக் காரணம் விளங்கவில்லை. போர் முடிந்து விட்டது. படைத் தலைவனாகிய அந்த வீரன் தன் படையாளருடைய ஊருக்கு மீண்டு வருகிறான். இப்பொழுது எதற்கு அவசரம்? போகும்போதுதான் அரசன் ஆணையை ஏற்றுத் தலைதெறிக்க ஓட வேண்டியிருந்தது.

'இது வரையில் நிதானமாகத்தானே வந்தோம்? இவரும் காட்டின் அழகைப் பார்த்து வந்தாரே. இதற்குள் திடீரென்று இப்படி உத்தரவிடுகிறாரே' என்று எண்ணி வீரனைத் திரும்பிப் பார்த்தான்.

"குதிரையின் வேகத்தை இன்று அளந்து காட்ட வேண்டும். இதுவரையில் நீ தாற்றுக்கோலை உபயோகித்ததே இல்லை. அது இங்கே துருப்பிடித்துக் கிடக்கிறது.



## 7. பண்டைய போர் முறைகளும், மரபுகளும்

Mrs. D. திருமுருகன்

உதவிப்பேராசிரியர் , தமிழ்த் துறை ,

பொன்னையா ராமஜெயம் நிகர் நிலை

பல்கலைக்கழகம், வல்லம், தஞ்சாவூர்

இயற்கையின் சுற்றுப்புறச் சூழலுக்கு ஏற்றவாறே ஒவ்வொரு நிலத்துள் வாழும் உயிரினங்களின் செயல்கள் யாவும் அமைகின்றன. அது மட்டுமின்றி, புற உலகினில் தம்மைத் தகவமைத்துக் கொண்டு வாழும் உயிரினங்கள் பிற உயிரினங்களிடமிருந்து தம்மைப் பாதுகாத்துக் கொள்வதற்கான சூழலையும் முதன்மை யம்சமாய் பெற்றே உயிர்களின் வாழ்வு அமைகின்றது. இவ்வுயிரினங்களிலேயே மனிதன் தனித்த வளர்ச்சியை எய்தினான். மனிதனை பொறுத்தமட்டில் வேட்டையாடுதலில் தொடங்கிய பயணம் கால்நடை வளர்ப்பு, சிறு சாகுபடியென புத்துயிர் பெற்று, உற்பத்திக் கருவிகளை உருவாக்கி, நிலையானதொரு வாழ்வைத் தொடங்கினான் எனலாம். எனின், இஃது பெரும் பேராட்டத்தின் விளைவேயாகும்.

இனக்குழு வாழ்வில் வேட்டையில் கவனம் செலுத்தியவன், உணவுக்கான பெரும் போராட்டத்தை சந்திக்க வேண்டியிருந்தது. உணவு பற்றாக்குறையே அதன் முதன்மை காரணி என்பர் சமூகவியலாளர். அதன் பின்னர் தனிநபருக்குரிய சொத்தாய் மாற்றம் பெற்ற காலம் தான் போராட்டத்தின் விளைவுகளை எல்லையில்லாது தோற்றுவித்தது. ஒரு குழு பிற குழுவை அடிமைப்படுத்துவதும், ஓர் குழுவினரேளாரையே அக்குழுவினரேள சிலர் அடிமைப்படுத்தியும், உற்பத்தி செய்யவும், ஏவல் தொழில் செய்யவும் நிர்ப்பந்தப்படுத்தியும் போரிட்டு வெற்றி பெற்று வரவும் என பலவகையில் நிர்ப்பந்திக்கப்பட்டனர்.

குறிப்பாக அடிமைச் சமூகம், மன்னர் சமூகத்தில் மேற்கூறிய காரணங்களே முதன்மை காரணியாய் இருந்தன. போர்கள் அடிப்படையில் செல்வப் பெருக்கம், எல்லையை விரிவுபடுத்துதல், மண்ணாசை, வலிமை கருதுதல், யார் பெரியவன் எனும் போக்கு, ஓர் குடும்பத்திற்குள்ளான முரண் ஆகியன அடிப்படைக் காரணியாய் அமைந்திருக்கின்றன



# BIOCHEMICAL TOXICOLOGY

Edited By

**DR. A. SOHNA CHANDRA BACKIAVATHI**



978-93-6255-451-2

Biochemical Toxicology

Copyright © 2018 by Dr. A. Sohna Chandra Backiavathi

All rights reserved. No part of this book may be reproduced or transmitted in any form or by any means without written permission from the author.

**ISBN: 978-93-6255-451-2**



Publisher: Ponnaiyah Ramajayam Institute of Science and  
Technology (PRIST)

# TABLE OF CONTENTS

---

---

<b>Chapter 1</b>	<b>Dr. A. Sohna Chandra Backiavathi</b>	<b>1</b>
THE PRACTICE OF MEDICINE		
<b>Chapter 2</b>	<b>Dr. A. Bakrudeen Ali Ahmed</b>	<b>21</b>
DECISION-MAKING IN CLINICAL MEDICINE		
<b>Chapter 3</b>		<b>35</b>
PRINCIPLES OF CLINICAL PHARMACOLOGY	<b>Dr. M. Vijay</b>	
<b>Chapter 4</b>		<b>48</b>
SCREENING AND PREVENTION OF DISEASE	<b>Dr. S. Ambiga</b>	
<b>Chapter 5</b>	<b>Dr. S. Sathishkumar</b>	<b>59</b>
PAIN: PATHOPHYSIOLOGY AND MANAGEMENT		
<b>Chapter 6</b>	<b>Dr. Binugeorge</b>	<b>74</b>
ABDOMINAL PAIN		
<b>Chapter 7</b>	<b>Mr. R. Viswalingam</b>	<b>88</b>
HEADACHE		

=====



# CHAPTER 1

## THE PRACTICE OF MEDICINE

Dr. A. Sohna Chandra Backiavathi

### 1 THE PRACTICE OF MEDICINE

The Editors

**WHAT IS EXPECTED OF THE PHYSICIAN** The accelerating pace of change in medicine stems from an explosion of scientific information and the need to blend this information into the art and practice of medicine.

The role of *science in medicine* is clear. Science-based technology and deductive reasoning form the foundation for the solution to many clinical problems. Spectacular advances in genetics, biochemistry, and imaging techniques allow access to the innermost parts of the cell and the most remote recesses of the body. Revelations about the nature of genes and single cells have opened the portal for formulating a new molecular basis for the physiology of systems. These physiologic insights will undoubtedly result in a better understanding of complex disease processes and new approaches to disease treatment and prevention. Highly advanced therapeutic maneuvers are increasingly a major part of medical practice. Yet skill in the most sophisticated application of laboratory technology and in the use of the latest therapeutic modality alone does not make a good physician.

The editors of the first edition of this book articulated well the responsibility of the physician in interacting with the patient:

*No greater opportunity, responsibility, or obligation can fall to the lot of a human being than to become a physician. In the care of the suffering, [the physician] needs technical skill, scientific knowledge, and human understanding. . . . Tact, sympathy, and understanding are expected of the physician, for the patient is no mere collection of symptoms, signs, disordered functions, damaged organs, and disturbed emotions. [The patient] is human, fearful, and hopeful, seeking relief, help, and reassurance.*

When a patient poses challenging clinical problems, an effective physician must be able to identify the crucial elements in a complex history and physical examination and to extract the key laboratory results from the crowded computer printouts of data in order to determine whether to “treat” or to “watch.” Deciding whether a clinical clue is worth pursuing or should be dismissed as a “red herring” and weighing whether a proposed treatment entails a greater risk than the disease itself are essential judgments that the skilled clinician must make many times each day. This combination of medical knowledge, intuition, experience, and judgment defines the *art of medicine*, which is as necessary to the practice of medicine as is a sound scientific base.

**THE PATIENT-PHYSICIAN RELATIONSHIP: A HUMANE APPROACH IN THE FACE OF CHANGE** In this era of “techno-medicine,” physicians need to approach patients not as “cases” or “diseases” but as individuals whose problems all too often transcend their physical complaints. Most patients are anxious and fearful. Physicians should instill confidence and should be reassuring (as depicted humorously in Fig. 1-1) but should never be arrogant. A professional attitude, coupled with warmth and openness, can do much to alleviate anxiety and to encourage patients to share all aspects of their medical history. Whatever the patient’s attitude, the physician needs to consider the setting in which an illness occurs—in terms not only of the patients themselves but also of their familial, social, and cultural backgrounds. The ideal patient-physician relationship is based on thorough knowledge of the patient, on mutual trust, and on the ability to communicate.

**Technological Complexity and Managed Care** The one-to-one patient-physician relationship, which has traditionally characterized the practice of medicine, is increasingly in jeopardy because of the growing complexity of medicine and the changes in health care delivery systems. Often the management of an individual patient is a team effort in-

volving a number of physicians and other professional personnel. Increasingly, hospitalists assume the responsibility for patient management in the inpatient setting. The patient can benefit greatly from effective collaboration among health care professionals, but *it is the duty of the patient’s principal physician to provide guidance through an illness.* To carry out this difficult task, this physician must be familiar with the techniques, skills, and objectives of specialist physicians and of colleagues in the fields allied to medicine. In giving the patient an opportunity to benefit from scientific advances, the primary physician must retain responsibility for the major decisions concerning diagnosis and treatment.

The practice of medicine in a managed-care setting puts additional stress on the patient-physician relationship. Whatever the potential advantages of organized medical groups such as health maintenance organizations (HMOs), there are also drawbacks, including the loss of the clear identification of the physician who is primarily and continuously responsible for the patient. Even under these circumstances, it is essential for each patient to have a physician who has an overview of the problems and who is familiar with the patient’s reaction to the illness, the drugs the patient is given, and the challenges the patient faces. Moreover, in managed-care settings, many physicians must treat patients within a restricted time frame, with limited access to specialists, and under organizational guidelines that may compromise their ability to exercise their individual clinical judgment. As difficult as these restrictions may be, it is the ultimate responsibility of the physician, in close consultation with the patient, to determine what is best for the patient. This responsibility cannot be relinquished in the name of compliance with organizational guidelines.

**The Modern Hospital Environment** The physician must be aware that the hospital is an intimidating environment for most individuals. Hospitalized patients find themselves surrounded by air jets, buttons, and lights; invaded by tubes and wires; and beset by the numerous members of the health care team—nurses, nurses’ aides, physicians’ assistants, social workers, technologists, physical therapists, medical students, house officers, attending and consulting physicians, and many others. They may be transported to special laboratories and imaging facilities replete with blinking lights, strange sounds, and unfamiliar personnel; they may be obliged to share a room with other patients who have their own health problems. It is little wonder that



**FIGURE 1-1** Although physicians must be confident and reassuring, it may be possible to go too far. (The New Yorker Collection 2000, David Sipress, from cartoonbank.com. All Rights Reserved.)



# CHAPTER 2

## DECISION-MAKING IN CLINICAL MEDICINE

Dr. A. BAKRUDEEN ALI AHMED

### Introduction

To the medical student who requires 2 h to collect a patient's history and perform a physical examination, and several additional hours to organize them into a coherent presentation, the experienced clinician's ability to reach a diagnosis and decide on a management plan in a fraction of the time seems extraordinary. While medical knowledge and experience play a significant role in the senior clinician's ability to arrive at a differential diagnosis and plan quickly, much of the process involves skill in clinical decision-making. The first goal of this chapter is to provide an introduction to the study of clinical reasoning.

Equally bewildering to the student are the proper use of diagnostic tests and the integration of the results into the clinical assessment. The novice medical practitioner typically uses a "shotgun" approach to testing, hoping to hit a target without knowing exactly what that target is. The expert, on the other hand, usually has a specific target in mind and efficiently adjusts the testing strategy to it. The second goal of this chapter is to review briefly some of the crucial basic statistical concepts that govern the proper interpretation and use of diagnostic tests; quantitative tools available to assist in clinical decision-making will also be discussed.

*Evidence-based medicine* is the term used to describe the integration of the best available research evidence with clinical judgment and experience in the care of patients. The third goal of this chapter is to provide a brief overview of some of the tools of evidence-based medicine.

### CLINICAL DECISION-MAKING

**CLINICAL REASONING** The most important clinical actions are not procedures or prescriptions but the judgments from which all other aspects of clinical medicine flow. In the modern era of large randomized trials and evidence-based medicine, it is easy to overlook the importance of this elusive mental activity and focus instead on the algorithmic practice guidelines constructed to improve care. One reason for this apparent neglect is that much more research has been done on how doctors *should* make decisions (e.g., using a Bayesian model discussed below) than on how they actually *do*. Thus, much of what we know about clinical reasoning comes from empirical studies of nonmedical problem-solving behavior.

Despite the great technological advances of the twentieth century, uncertainty still plays a pivotal role in all aspects of medical decision-making. We may know that a patient does not have long to live, but we cannot be certain how long. We may prescribe a potent new receptor blocker to reverse the course of a patient's illness, but we cannot be certain that the therapy will achieve the desired result and that result alone. Uncertainty in medical outcomes creates the need for probabilities and other mathematical/statistical tools to help guide decision-making. (These tools are reviewed later in the chapter.)

Uncertainty is compounded by the information overload that characterizes modern medicine. Today's experienced clinician needs close to 2 million pieces of information to practice medicine. Doctors subscribe to an average of 7 journals, representing over 2500 new articles each year. Computers offer the obvious solution both for management

of information and for better quantitation and management of the daily uncertainties of medical care. While the technology to computerize medical practice is available, many practical problems remain to be solved before patient information can be standardized and integrated with medical evidence on a single electronic platform.

The following three examples introduce the subject of clinical reasoning:

- A 46-year-old man presents to his internist with a chief complaint of hemoptysis. The physician knows that the differential diagnosis of hemoptysis includes over 100 different conditions, including cancer and tuberculosis (Chap. 30). The examination begins with some general background questions, and the patient is asked to describe his symptoms and their chronology. By the time the examination is completed, and even before any tests are run, the physician has formulated a working diagnostic hypothesis and planned a series of steps to test it. In an otherwise healthy and nonsmoking patient recovering from a viral bronchitis, the doctor's hypothesis would be that the acute bronchitis is responsible for the small amount of blood-streaked sputum the patient observed. In this case, a chest x-ray may provide sufficient reassurance that a more serious disorder is not present.
- A second 46-year-old patient with the same chief complaint who has a 100-pack-year smoking history, a productive morning cough, and episodes of blood-streaked sputum may generate the principal diagnostic hypothesis of carcinoma of the lung. Consequently, along with the chest x-ray, the physician obtains a sputum cytology examination and refers this patient for fiberoptic bronchoscopy.
- A third 46-year-old patient with hemoptysis who is from a developing country is evaluated with an echocardiogram as well, because the physician thinks she hears a soft diastolic rumble at the apex on cardiac auscultation, suggesting rheumatic mitral stenosis.

These three simple vignettes illustrate two aspects of expert clinical reasoning: (1) the use of cognitive shortcuts as a way to organize the complex unstructured material that is collected in the clinical evaluation, and (2) the use of diagnostic hypotheses to consolidate the information and indicate appropriate management steps.

**THE USE OF COGNITIVE SHORTCUTS** Cognitive shortcuts or rules of thumb, sometimes referred to as *heuristics*, can help solve complex problems, of the sort encountered daily in clinical medicine, with great efficiency. Clinicians rely on three basic types of heuristics. When assessing a patient, clinicians often weigh the probability that this patient's clinical features match those of the class of patients with the leading diagnostic hypotheses being considered. In other words, the clinician is searching for the diagnosis for which the patient appears to be a representative example; this cognitive shortcut is called the *representativeness heuristic*.

It may take only a few characteristics from the history for an expert clinician using the representativeness heuristic to arrive at a sound diagnostic hypothesis. For example, an elderly patient with new-onset fever, cough productive of copious sputum, unilateral pleuritic chest



# CHAPTER 3

## PRINCIPLES OF CLINICAL PHARMACOLOGY

Dr. M. Vijay

Drugs are the cornerstone of modern therapeutics. Nevertheless, it is well recognized among physicians and among the lay community that the outcome of drug therapy varies widely among individuals. While this variability has been perceived as an unpredictable, and therefore inevitable, accompaniment of drug therapy, this is not the case. The goal of this chapter is to describe the principles of clinical pharmacology that can be used for the safe and optimal use of available and new drugs.

Drugs interact with specific target molecules to produce their beneficial and adverse effects. The chain of events between administration of a drug and production of these effects in the body can be divided into two important components, both of which contribute to variability in drug actions. The first component comprises the processes that determine drug delivery to, and removal from, molecular targets. The resultant description of the relationship between drug concentration and time is termed *pharmacokinetics*. The second component of variability in drug action comprises the processes that determine variability in drug actions despite equivalent drug delivery to effector drug sites. This description of the relationship between drug concentration and effect is termed *pharmacodynamics*. As discussed further below, pharmacodynamic variability can arise as a result of variability in function of the target molecule itself or of variability in the broad biologic context in which the drug-target interaction occurs to achieve drug effects.

Two important goals of the discipline of clinical pharmacology are (1) to provide a description of conditions under which drug actions vary among human subjects; and (2) to determine mechanisms underlying this variability, with the goal of improving therapy with available drugs as well as pointing to new drug mechanisms that may be effective in the treatment of human disease. The first steps in the discipline were empirical descriptions of the influence of disease X on drug action Y or of individuals or families with unusual sensitivities to adverse drug effects. These important descriptive findings are now being replaced by an understanding of the molecular mechanisms underlying variability in drug actions. Thus, the effects of disease, drug coadministration, or familial factors in modulating drug action can now be reinterpreted as variability in expression or function of specific genes whose products determine pharmacokinetics and pharmacodynamics. Nevertheless, it is the personal interaction of the patient with the physician or other health care provider that first identifies unusual variability in drug actions; maintained alertness to unusual drug responses continues to be a key component of improving drug safety.

Unusual drug responses, segregating in families, have been recognized for decades and initially defined the field of *pharmacogenetics*. Now, with an increasing appreciation of common polymorphisms across the human genome, comes the opportunity to reinterpret de-

scriptive mechanisms of variability in drug action as a consequence of specific DNA polymorphisms, or sets of DNA polymorphisms, among individuals. This approach defines the nascent field of *pharmacogenomics*, which may hold the opportunity of allowing practitioners to integrate a molecular understanding of the basis of disease with an individual's genomic makeup to prescribe personalized, highly effective, and safe therapies.

**INDICATIONS FOR DRUG THERAPY** It is self-evident that the benefits of drug therapy should outweigh the risks. Benefits fall into two broad categories: those designed to alleviate a symptom, and those designed to prolong useful life. An increasing emphasis on the principles of evidence-based medicine and techniques such as large clinical trials and meta-analyses have defined benefits of drug therapy in specific patient subgroups. Establishing the balance between risk and benefit is not always simple: for example, therapies that provide symptomatic benefits but shorten life may be entertained in patients with serious and highly symptomatic diseases such as heart failure or cancer. These decisions illustrate the continuing highly personal nature of the relationship between the prescriber and the patient.

Some adverse effects are so common, and so readily associated with drug therapy, that they are identified very early during clinical use of a drug. On the other hand, serious adverse effects may be sufficiently uncommon that they escape detection for many years after a drug begins to be widely used. The issue of how to identify rare but serious adverse effects (that can profoundly affect the benefit-risk perception in an individual patient) has not been satisfactorily resolved. Potential approaches range from an increased understanding of the molecular and genetic basis of variability in drug actions to expanded postmarketing surveillance mechanisms. None of these have been completely effective, so practitioners must be continuously vigilant to the possibility that unusual symptoms may be related to specific drugs, or combinations of drugs, that their patients receive.

Beneficial and adverse reactions to drug therapy can be described by a series of dose-response relations (Fig. 3-1). Well-tolerated drugs demonstrate a wide margin, termed the *therapeutic ratio*, *therapeutic index*, or *therapeutic window*, between the doses required to produce a therapeutic effect and those producing toxicity. In cases where there is a similar relationship between plasma drug concentration and effects, monitoring plasma concentrations can be a highly effective aid in managing drug therapy, by enabling concentrations to be maintained above the minimum required to produce an effect and below the concentration range likely to produce toxicity. Such monitoring has been most widely used to guide therapy with specific agents, such as certain antiarrhythmics, anticonvulsants, and antibiotics. Many of the principles in clinical pharmacology and examples outlined below—that can



# CHAPTER 4

## SCREENING AND PREVENTION OF DISEASE

Dr. S. Ambiga

A primary goal of health care is to prevent disease or to detect it early enough that interventions will be more effective. Strategies for disease screening and prevention are driven by evidence that testing and interventions are practical and effective. Most screening tests are currently based on readily available and inexpensive biochemical (e.g., cholesterol), physiologic (e.g., blood pressure), radiologic (e.g., mammogram), or tissue specimens (e.g., Pap smear). In the future, it is anticipated that genetic testing will play an increasingly important role for predicting disease risk (Chap. 58). However, such tests are not widely used except for individuals at risk for high-penetrance genes based on family or ethnic history (e.g., *BRCA1*, *BRCA2*). The identification of low-penetrance but high-frequency genes that cause common disorders such as diabetes or hypertension offers the possibility of new genetic tests. However, any new screening test, whether based on genetic or other methods, must be subjected to rigorous evaluation of its sensitivity, specificity, impact on disease, and cost-effectiveness. Physicians and patients are continuously introduced to new screening tests, often in advance of complete evaluation. For example, the use of whole-body computed tomography imaging has been advocated as a means to screen for a variety of disorders. Though appealing in concept, there is currently no evidence to justify this approach, which is associated with high cost and a substantial risk of false-positive results.

This chapter will review the basic principles of screening and strategies for measuring the impact of screening and prevention and will provide a summary of recommendations for screening and prevention in the primary care setting. Recommendations for specific disorders, such as cardiovascular disease, diabetes, or cancer, are provided in the chapters dedicated to these topics.

**BASIC PRINCIPLES OF SCREENING** In general, screening is most effective when applied to relatively common disorders that carry a large disease burden (Table 4-1). The five leading causes of mortality in the United States are heart diseases, malignant neoplasms, accidents, cerebrovascular diseases, and chronic obstructive pulmonary disease. Thus, many prevention strategies are targeted at these conditions.

A primary goal of screening is the early detection of a risk factor or disease at a stage when it can be corrected or cured. For example, most cancers have a better prognosis when identified as premalignant lesions or when they are still resectable. Similarly, early identification of hypertension or hyperlipidemia allows therapeutic interventions that reduce the risk of cardiovascular or cerebrovascular events. However, early detection does not necessarily influence survival. For example, in some studies of lung cancer screening, tumors are identified at an earlier stage, but overall mortality does not differ between screened and unscreened populations. The apparent improvement in 5-year survival rates can be attributed to the detection of smaller tumors rather than a real change in clinical course after diagnosis. Similarly, the detection of prostate cancer may not lead to a mortality difference because the disease is often indolent and competing morbidities, such as coronary artery disease, may ultimately cause mortality (Chap. 67).

Disorders with a long latency period increase the potential gains associated with detection. For example, cancer of the cervix has a long latency between dysplasia and invasive carcinoma, providing an opportunity for detection by routine screening. Similarly, an adenoma-

tous polyp progresses to invasive colon cancer over 4 to 12 years, allowing an opportunity to detect early lesions by fecal occult blood testing or endoscopy. On the other hand, breast cancer screening in premenopausal women is more challenging because of the relatively short interval between development of a localized breast cancer and metastasis to regional nodes (estimated to be ~12 months).

**METHODS OF MEASURING HEALTH BENEFITS** It is not practical to perform all possible screening procedures. For example, screening for laryngeal cancer in smokers is not currently recommended. It is necessary to examine the strength of evidence in favor of screening measures relative to the cost and risk of false-positive tests. For example, should ultrasound be used to screen for ovarian cancer in average-risk women? It is currently estimated that the unnecessary laparotomies triggered by finding benign ovarian masses would actually cause more harm than the benefit derived from detecting the occasional curable ovarian cancer.

A variety of end points are used to assess the potential gain from screening and prevention interventions:

1. *The number of subjects screened to alter the outcome in one individual.* It is estimated, for example, that 731 women aged 65 to 69 would need to be screened by dual-energy x-ray absorptiometry (DEXA) and then treated appropriately to prevent one hip fracture from osteoporosis.

2. *The absolute and relative impact of screening on disease outcome.* A meta-analysis of Swedish mammography trials (ages 40 to 70) found that ~1.2 fewer women per thousand would die from breast cancer if they were screened over a 12-year period. By comparison, ~3 lives per 1000 might be saved from colon cancer in a population (ages 50 to 75) screened with annual fecal occult blood testing (FOBT) over a 13-year period. Based on this analysis, colon cancer screening may actually save more women's lives than mammography. The impact of FOBT (8.8/1000 versus 5.9/1000) might be stated as either 3 lives per 1000, or as a 30% reduction in colon cancer death; thus, it is important to consider both the relative and absolute impact on numbers of lives saved.

3. *The cost per year of life saved.* This is used to assess the effectiveness of many screening and prevention strategies. Typically, strategies that cost <\$30,000 to \$50,000 per year of life saved are considered "cost effective" (Chap. 2). For example, using alendronate to treat 65-year-old women with osteoporosis approaches this threshold of approximately \$30,000 per year of life saved.

4. *Increase in average life expectancy for a population.*

Predicted increases in life expectancy for various screening procedures are listed in Table 4-2. It should be noted, however, that the life expectancy increase is an average that applies to a population and not to an individual. In reality, the vast majority of the screened population does not derive any benefit and possibly incurs a slight risk

TABLE 4-1 Lifetime Cumulative Risk

Breast cancer for women	10%
Colon cancer	6%
Cancer of the cervix for women <sup>a</sup>	2%
Domestic violence for women	Up to 15%
Hip fracture for Caucasian women	16%

<sup>a</sup> Assuming an unscreened population.

TABLE 4-2 Estimated Average Increase in Life Expectancy for a Population

Screening Procedure	Average Increase
Mammography:	
Women, 40–50 years	0–5 days
Women, 50–70 years	1 month
Pap smears, age 18–65	2–3 months
Screening treadmill for a 50-year-old (asymptomatic) man	8 days
PSA and digital rectal exam for a man >50 years	Up to 2 weeks
Getting a 35-year-old smoker to quit	3–5 years
Beginning regular exercise for a 40-year-old man (30 min 3 times a week)	9 months to 2 years

Note: PSA, prostate-specific antigen.



# CHAPTER 5

## PAIN: PATHOPHYSIOLOGY AND MANAGEMENT

Dr. S. Sathishkumar

The task of medicine is to preserve and restore health and to relieve suffering. Understanding pain is essential to both these goals. Because pain is universally understood as a signal of disease, it is the most common symptom that brings a patient to a physician's attention. The function of the pain sensory system is to protect the body and maintain homeostasis. It does this by detecting, localizing, and identifying tissue-damaging processes. Since different diseases produce characteristic patterns of tissue damage, the quality, time course, and location of a patient's pain complaint and the location of tenderness provide important diagnostic clues and are used to evaluate the response to treatment. Once this information is obtained, it is the obligation of the physician to provide rapid and effective pain relief.

### THE PAIN SENSORY SYSTEM

Pain is an unpleasant sensation localized to a part of the body. It is often described in terms of a penetrating or tissue-destructive process (e.g., stabbing, burning, twisting, tearing, squeezing) and/or of a bodily or emotional reaction (e.g., terrifying, nauseating, sickening). Furthermore, any pain of moderate or higher intensity is accompanied by anxiety and the urge to escape or terminate the feeling. These properties illustrate the duality of pain: it is both sensation and emotion. When acute, pain is characteristically associated with behavioral arousal and a stress response consisting of increased blood pressure, heart rate, pupil diameter, and plasma cortisol levels. In addition, local muscle contraction (e.g., limb flexion, abdominal wall rigidity) is often present.

**PERIPHERAL MECHANISMS ■ The Primary Afferent Nociceptor** A peripheral nerve consists of the axons of three different types of neurons: primary sensory afferents, motor neurons, and sympathetic postganglionic neurons (Fig. 11-1). The cell bodies of primary afferents are located in the dorsal root ganglia in the vertebral foramina. The primary afferent axon bifurcates to send one process into the spinal cord and the other to innervate tissues. Primary afferents are classified by their diameter, degree of myelination, and conduction velocity. The largest-diameter fibers, A-beta ( $A\beta$ ), respond maximally to light touch and/or moving stimuli; they are present primarily in nerves that innervate the skin. In normal individuals, the activity of these fibers does not produce pain. There are two other classes of primary afferents: the small-diameter myelinated A-delta ( $A\delta$ ) and the unmyelinated (C fiber) axons (Fig. 11-1). These fibers are present in nerves to the skin and to deep somatic and visceral structures. Some tissues, such as the cornea, are innervated only by  $A\delta$  and C afferents. Most  $A\delta$  and C afferents respond maximally only to intense (painful) stimuli and produce the subjective experience of pain when they are electrically stimulated; this defines them as *primary afferent nociceptors (pain receptors)*. The ability to detect painful stimuli is completely abolished when  $A\delta$  and C axons are blocked.

Individual primary afferent nociceptors can respond to several different types of noxious

stimuli. For example, most nociceptors respond to heating, intense mechanical stimuli such as a pinch, and application of irritating chemicals.

**Sensitization** When intense, repeated, or prolonged stimuli are applied to damaged or inflamed tissues the threshold for activating primary afferent nociceptors is lowered and the frequency of firing is higher for all stimulus intensities. Inflammatory mediators such as bradykinin, some prostaglandins, and leukotrienes contribute to this process, which is called *sensitization*. In sensitized tissues normally innocuous stimuli can produce pain. Sensitization is a clinically important process that contributes to tenderness, soreness, and hyperalgesia. A striking example of sensitization is sunburned skin, in which severe pain can be produced by a gentle slap on the back or a warm shower.

Sensitization is of particular importance for pain and tenderness in deep tissues. Viscera are normally relatively insensitive to noxious mechanical and thermal stimuli, although hollow viscera do generate significant discomfort when distended. In contrast, when affected by a disease process with an inflammatory component, deep structures such as joints or hollow viscera characteristically become exquisitely sensitive to mechanical stimulation.

A large proportion of  $A\delta$  and C afferents innervating viscera are completely insensitive in normal noninjured, noninflamed tissue. That is, they cannot be activated by known mechanical or thermal stimuli and are not spontaneously active. However, in the presence of inflammatory mediators, these afferents become sensitive to mechanical stimuli. Such afferents have been termed *silent nociceptors*, and their characteristic properties may explain how under pathologic conditions the relatively insensitive deep structures can become the source of severe and debilitating pain and tenderness. Low pH, prostaglandins, leukotrienes, and other inflammatory mediators such as bradykinin play a significant role in sensitization.

**Nociceptor-Induced Inflammation** One important concept to emerge in recent years is that afferent nociceptors also have a neuroeffector func-

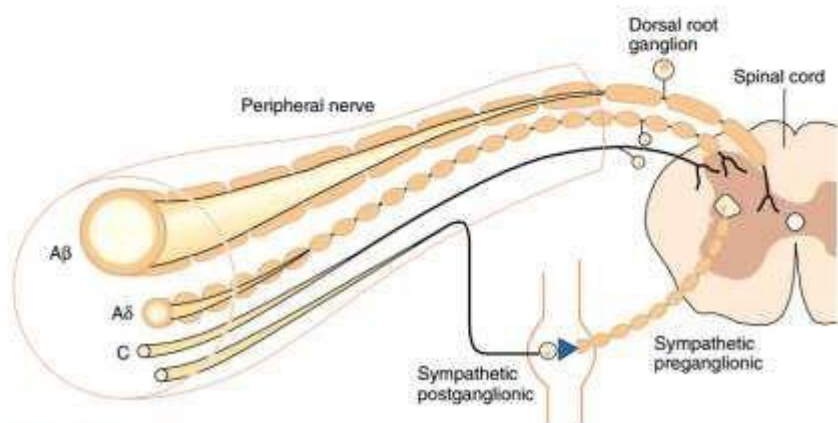

**FIGURE 11-1** Components of a typical cutaneous nerve. There are two distinct functional categories of axons: primary afferents with cell bodies in the dorsal root ganglion, and sympathetic postganglionic fibers with cell bodies in the sympathetic ganglion. Primary afferents include those with large-diameter myelinated ( $A\beta$ ), small-diameter myelinated ( $A\delta$ ), and unmyelinated (C) axons. All sympathetic postganglionic fibers are unmyelinated.



# CHAPTER 6

## ABDOMINAL PAIN

Dr. Binugeorge

The correct interpretation of acute abdominal pain is challenging. Since proper therapy may require urgent action, the unhurried approach suitable for the study of other conditions is sometimes denied. Few other clinical situations demand greater judgment, because the most catastrophic of events may be forecast by the subtlest of symptoms and signs. A meticulously executed, detailed history and physical examination are of great importance. The etiologic classification in Table 13-1, although not complete, forms a useful basis for the evaluation of patients with abdominal pain.

The diagnosis of "acute or surgical abdomen" is not an acceptable one because of its often misleading and erroneous connotation. The most obvious of "acute abdomens" may not require operative intervention, and the mildest of abdominal pains may herald an urgently correctable lesion. Any patient with abdominal pain of recent onset requires early and thorough evaluation and accurate diagnosis.

**SOME MECHANISMS OF PAIN ORIGINATING IN THE ABDOMEN** ■ **Inflammation of the Parietal Peritoneum** The pain of parietal peritoneal inflammation is steady and aching in character and is located directly over the inflamed area, its exact reference being possible because it is transmitted by somatic nerves supplying the parietal peritoneum. The intensity of the pain is dependent on the type and amount of material to which the peritoneal surfaces are exposed in a given time period. For example, the sudden release into the peritoneal cavity of a small quantity of sterile acid gastric juice causes much more pain than the same amount

not been sudden and massive. In the case of bacterial contamination, such as in pelvic inflammatory disease, the pain is frequently of low intensity early in the illness until bacterial multiplication has caused the elaboration of irritating substances.

The rate at which the irritating material is applied to the peritoneum is important. Perforated peptic ulcer may be associated with entirely different clinical pictures dependent only on the rapidity with which the gastric juice enters the peritoneal cavity.

*The pain of peritoneal inflammation is invariably accentuated by pressure or changes in tension of the peritoneum, whether produced by palpation or by movement, as in coughing or sneezing.* The patient with peritonitis lies quietly in bed, preferring to avoid motion, in contrast to the patient with colic, who may writhe incessantly.

Another characteristic feature of peritoneal irritation is tonic reflex spasm of the abdominal musculature, localized to the involved body segment. The intensity of the tonic muscle spasm accompanying peritoneal inflammation is dependent on the location of the inflammatory process, the rate at which it develops, and the integrity of the nervous system. Spasm over a perforated retrocecal appendix or perforated ulcer into the lesser peritoneal sac may be minimal or absent because of the protective effect of overlying viscera. A slowly developing process often greatly attenuates the degree of muscle spasm. Catastrophic abdominal emergencies such as a perforated ulcer may be associated with minimal or no detectable pain or muscle spasm in obtunded, seriously ill, debilitated elderly patients or in psychotic patients.

**Obstruction of Hollow Viscera** The pain of obstruction of hollow abdominal viscera is classically described as intermittent, or colicky. Yet the lack of a truly cramping character should not be misleading, because distention of a hollow viscus may produce steady pain with only very occasional exacerbations. It is not nearly as well localized as the pain of parietal peritoneal inflammation.

The colicky pain of obstruction of the small intestine is usually periumbilical or supraumbilical and is poorly localized. As the intestine becomes progressively dilated with loss of muscular tone, the colicky nature of the pain may diminish. With superimposed strangulating obstruction, pain may spread to the lower lumbar region if there is traction on the root of the mesentery. The colicky pain of colonic obstruction is of lesser intensity than that of the small intestine and is often located in the infraumbilical area. Lumbar radiation of pain is common in colonic obstruction.

Sudden distention of the biliary tree produces a steady rather than colicky type of pain; hence the term *biliary colic* is misleading. Acute distention of the gallbladder usually causes pain in the right upper quadrant with radiation to the right posterior region of the thorax or to the tip of the right scapula, and distention of the common bile duct is often associated with pain in the epigastrium radiating to the upper part of the lumbar region. Considerable variation is common, however, so that differentiation between these may be impossible. The typical subscapular pain or lumbar radiation is frequently absent. Gradual dilatation of the biliary tree, as in carcinoma of the head of the pancreas, may cause no pain or only a mild aching sensation in the epigastrium or right upper quadrant. The pain of distention of the pancreatic ducts is similar to that described for distention of the common bile duct but, in addition, is very frequently accentuated by recumbency and relieved by the upright position.

Obstruction of the urinary bladder results in dull suprapubic pain, usually low in intensity. Restlessness without specific complaint of pain may be the only sign of a distended bladder in an obtunded patient. In contrast, acute obstruction of the intravesicular portion of the ureter is characterized by severe suprapubic and flank pain that radiates to the penis, scrotum, or inner aspect of the upper thigh. Obstruction of the ureteropelvic junction is felt as pain in the costovertebral angle, whereas obstruction of the remainder of the ureter is as-

TABLE 13-1 Some Important Causes of Abdominal Pain

### PAIN ORIGINATING IN THE ABDOMEN

1. Parietal peritoneal inflammation
  - a. Bacterial contamination, e.g., perforated appendix, pelvic inflammatory disease
  - b. Chemical irritation, e.g., perforated ulcer, pancreatitis, mittelschmerz
2. Mechanical obstruction of hollow viscera
  - a. Obstruction of the small or large intestine
  - b. Obstruction of the biliary tree
  - c. Obstruction of the ureter
3. Vascular disturbances
  - a. Embolism or thrombosis
  - b. Vascular rupture
  - c. Pressure or torsional occlusion
  - d. Sickle cell anemia
4. Abdominal wall
  - a. Distortion or traction of mesentery
  - b. Trauma or infection of muscles
5. Distention of visceral surfaces, e.g., hepatic or renal capsules

### PAIN REFERRED FROM EXTRAABDOMINAL SOURCE

1. Thorax, e.g., pneumonia, referred pain from coronary occlusion
2. Spine, e.g., radiculitis from arthritis, herpes zoster
3. Genitalia, e.g., torsion of the testicle

### METABOLIC CAUSES

1. Exogenous
  - a. Black widow spider bite
  - b. Lead poisoning and others
2. Endogenous
  - a. Uremia
  - b. Diabetic ketoacidosis
  - c. Porphyria
  - d. Allergic factors (C1 esterase inhibitor deficiency)

### NEUROGENIC CAUSES

1. Organic
  - a. Tabes dorsalis
  - b. Herpes zoster
  - c. Causalgia and others
2. Functional

# CHAPTER 7

## HEADACHE

Mr. R. Viswalingam

Few of us are spared the experience of head pain. As many as 90% of individuals have at least one headache per year. Severe, disabling headache is reported to occur at least annually by 40% of individuals worldwide. A useful classification of the many causes of headache is shown in Table 14-1. Headache is usually a benign symptom, but occasionally it is the manifestation of a serious illness such as brain tumor, subarachnoid hemorrhage, meningitis, or giant cell arteritis. In emergency settings, approximately 5% of patients with headache are found to have a serious underlying neurologic disorder. Therefore, it is imperative that the serious causes of headache be diagnosed rapidly and accurately.

### PAIN-SENSITIVE STRUCTURES OF THE HEAD

Pain usually occurs when peripheral nociceptors are stimulated in response to tissue injury, visceral distension, or other factors (Chap. 11). In such situations, pain perception is a normal physiologic response mediated by a healthy nervous system. Pain can also result when pain-sensitive pathways of the peripheral or central nervous system are damaged or activated inappropriately. Headache may originate from either or both mechanisms. Relatively few cranial structures are pain-sensitive: the scalp, middle meningeal artery, dural sinuses, falx cerebri, and the proximal segments of the large pial arteries. The ventricular ependyma, choroid plexus, pial veins, and much of the brain parenchyma are pain-insensitive. Electrical stimulation of the midbrain

nervous system via the trigeminal nerves for structures above the tentorium in the anterior and middle fossae of the skull, and via the first three cervical nerves for those in the posterior fossa and the inferior surface of the tentorium.

Headache can occur as the result of (1) distention, traction, or dilation of intracranial or extracranial arteries; (2) traction or displacement of large intracranial veins or their dural envelope; (3) compression, traction, or inflammation of cranial and spinal nerves; (4) spasm, inflammation, or trauma to cranial and cervical muscles; (5) meningeal irritation and raised intracranial pressure; or (6) other possible mechanisms such as activation of brainstem structures.

### GENERAL CLINICAL CONSIDERATIONS

The quality, location, duration, and time course of the headache and the conditions that produce, exacerbate, or relieve it should be carefully reviewed. Ascertaining the *quality* of cephalic pain is occasionally helpful for diagnosis. Most tension-type headaches are described as tight “bandlike” pain or as dull, deeply located, and aching pain. Jabbing, brief, sharp cephalic pain, often occurring multifocally (ice pick–like pain), is usually benign. A throbbing quality and tight muscles about the head, neck, and shoulder girdle are common nonspecific accompaniments of migraine headaches.

Pain *intensity* rarely has diagnostic value, although from the patient’s perspective, it is the single aspect of pain that is most important.

TABLE 14-1 International Headache Society Classification of Headache

<p><b>1. Migraine</b></p> <ul style="list-style-type: none"> <li>Migraine without aura</li> <li>Migraine with aura</li> <li>Ophthalmoplegic migraine</li> <li>Retinal migraine</li> <li>Childhood periodic syndromes that may be precursors to or associated with migraine</li> <li>Migrainous disorder not fulfilling above criteria</li> </ul> <p><b>2. Tension-type headache</b></p> <ul style="list-style-type: none"> <li>Episodic tension-type headache</li> <li>Chronic tension-type headache</li> </ul> <p><b>3. Cluster headache and chronic paroxysmal hemicrania</b></p> <ul style="list-style-type: none"> <li>Cluster headache</li> <li>Chronic paroxysmal hemicrania</li> </ul> <p><b>4. Miscellaneous headaches not associated with structural lesion</b></p> <ul style="list-style-type: none"> <li>Idiopathic stabbing headache</li> <li>External compression headache</li> <li>Cold stimulus headache</li> <li>Benign cough headache</li> <li>Benign exertional headache</li> <li>Headache associated with sexual activity</li> </ul> <p><b>5. Headache associated with head trauma</b></p> <ul style="list-style-type: none"> <li>Acute posttraumatic headache</li> <li>Chronic posttraumatic headache</li> </ul> <p><b>6. Headache associated with vascular disorders</b></p> <ul style="list-style-type: none"> <li>Acute ischemic cerebrovascular disorder</li> <li>Intracranial hematoma</li> <li>Subarachnoid hemorrhage</li> <li>Unruptured vascular malformation</li> <li>Arteritis</li> <li>Carotid or vertebral artery pain</li> <li>Venous thrombosis</li> <li>Arterial hypertension</li> <li>Other vascular disorder</li> </ul> <p><b>7. Headache associated with nonvascular intracranial disorder</b></p> <ul style="list-style-type: none"> <li>High CSF pressure</li> <li>Low CSF pressure</li> <li>Intracranial infection</li> </ul>	<p><b>7. Headache associated with nonvascular intracranial disorder (cont.)</b></p> <ul style="list-style-type: none"> <li>Sarcoidosis and other noninfectious inflammatory diseases</li> <li>Related to intrathecal injections</li> <li>Intracranial neoplasm</li> <li>Associated with other intracranial disorder</li> </ul> <p><b>8. Headache associated with substances or their withdrawal</b></p> <ul style="list-style-type: none"> <li>Headache induced by acute substance use or exposure</li> <li>Headache induced by chronic substance use or exposure</li> <li>Headache from substance withdrawal (acute use)</li> <li>Headache from substance withdrawal (chronic use)</li> </ul> <p><b>9. Headache associated with noncephalic infection</b></p> <ul style="list-style-type: none"> <li>Viral infection</li> <li>Bacterial infection</li> <li>Other infection</li> </ul> <p><b>10. Headache associated with metabolic disorder</b></p> <ul style="list-style-type: none"> <li>Hypoxia</li> <li>Hypercapnia</li> <li>Mixed hypoxia and hypercapnia</li> <li>Hypoglycemia</li> <li>Dialysis</li> <li>Other metabolic abnormality</li> </ul> <p><b>11. Headache or facial pain associated with disorder of facial or cranial structures</b></p> <ul style="list-style-type: none"> <li>Cranial bone</li> <li>Eyes</li> <li>Ears</li> <li>Nose and sinuses</li> <li>Teeth, jaws, and related structures</li> <li>Temporomandibular joint disease</li> </ul> <p><b>12. Cranial neuralgias, nerve trunk pain, and deafferentation pain</b></p> <ul style="list-style-type: none"> <li>Persistent (in contrast to ticlike) pain of cranial nerve origin</li> <li>Trigeminal neuralgia</li> <li>Glossopharyngeal neuralgia</li> <li>Nervus intermedius neuralgia</li> <li>Superior laryngeal neuralgia</li> <li>Occipital neuralgia</li> <li>Central causes of head and facial pain other than tic douloureux</li> </ul> <p><b>13. Headache not classifiable</b></p>
---	--



# PRINCIPLES OF **BIOCHEMICAL TOXICOLOGY**

EDITED BY  
**DR. BINUGEORGE**



978-93-6255-520-5

Principles of Biochemical Toxicology  
Copyright © 2018 by Dr. Binugeorge

All rights reserved. No part of this book may be reproduced or transmitted in any form or by any means without written permission from the author.

**ISBN: 978-93-6255-520-5**



Publisher: Ponnaiyah Ramajayam Institute of Science and  
Technology (PRIST)

# TABLE OF CONTENTS

---

---

<b>Chapter 1</b> Introduction	<b>Dr. Binugeorge</b>	<b>1</b>
<b>Chapter 2</b> Dose- Response Relationship	<b>Dr. G. Venkatkumar</b>	<b>21</b>
<b>Chapter 3</b> Factors Affecting Toxic Responses: Disposition	<b>Dr. RV. Shalini</b>	<b>35</b>
<b>Chapter 4</b> Factors affecting Toxic responses: Metabolism	<b>Dr. R. Arunkumar</b>	<b>48</b>
<b>Chapter 5</b> Factors Affecting Metabolism and Disposition	<b>Dr. J. Ilamathi</b>	<b>59</b>
<b>Chapter 6</b> Toxic responses to Foreign compounds	<b>Dr. R. Kamaraj</b>	<b>74</b>
<b>Chapter 7</b> Biochemical Mechanisms of Toxicity Specific Examples	<b>Mr. G. Rajendran</b>	<b>88</b>

---

---



---

# *Introduction*

---

---

## **1.1** *Background*

---

Toxicology is the subject concerned with the study of the noxious effects of chemical substances on living systems. It is a multi-disciplinary subject, as it embraces areas of pharmacology, biochemistry, chemistry, physiology and pathology, and although it has sometimes been considered as a subdivision of some of these other subjects, it is truly a scientific discipline in itself.

Toxicology may be regarded as the science of poisons; in this context it has been studied and practised since antiquity, and a large body of knowledge has been amassed. The ancient Greeks used hemlock and various other poisons, and **Dioscorides** attempted a classification of poisons. However, the scientific foundations of toxicology were laid by **Paracelsus** (1493–1541) and this approach was continued by **Orfila** (1787–1853). Nevertheless, development of toxicology as a separate science has been slow, particularly in comparison with subjects

such as pharmacology and biochemistry, and toxicology has a much more limited academic base. This may in part reflect the nature of the subject, which has evolved as a practical art, and also the fact that many practitioners were mainly interested in descriptive studies for screening purposes or to satisfy legislation.

---

## **1.2** *Scope*

---

The interest in and scope of toxicology continues to grow rapidly and the subject is of profound importance to human and animal health. The increasing numbers (currently around 100 000) of foreign chemicals (xenobiotics) to which humans and other organisms in the environment are exposed underlies this growth. These include drugs, pesticides, environmental pollutants, industrial chemicals and food additives about which we need to know much, particularly concerning their safety. Of particular importance, therefore, is the ability to predict

## *Dose-response relationships*

### **2.1** *Introduction*

The relationship between the dose of a compound and its toxicity is central in toxicology. **Paracelsus** (1493–1541), who was the first to put toxicology on a scientific basis, clearly recognized this relationship. His well-known statement ‘*All substances are poisons; there is none that is not a poison. The right dose differentiates a poison and a remedy*’, has immortalized the concept. Implicit in this statement is the premise that there is a dose of a compound which has no observable effect and another, higher dose, which causes the maximal response. The **dose-response relationship** involves quantifying the toxic effect and showing a correlation with exposure. The relationship underlies the whole of toxicology and an understanding of it is crucial. Parameters gained from it have various uses in both investigational and regulatory toxicology. It should be appreciated, however, that toxicity is a *relative* phenomenon and that the ways of measuring it are many and various.

### **2.2** *Criteria of toxicity*

The simplest measurement of toxicity is lethality, as quantified in the  $LD_{50}$ , but this end-point is a relatively crude measure and gives little information about the underlying basis of the toxicity. The variability is usually considerable, as the end-point is often dependent on a number of physiological or biochemical processes. However, there is scope for observation of toxic effects so that the information gained is more than a simple number. There are many other criteria of toxicity, not necessarily complex, which may be used in initial toxicity studies. An initial acute toxicity study may therefore simply observe the animals exposed to a range of doses without attempting to determine the lethal dose. Careful observation of the toxic signs may give valuable insight into possible mechanisms underlying the toxic effect. For example, an organophosphorus insecticide which affects the neuromuscular and central nervous systems in mammals may cause a variety of signs including salivation, diarrhoea,

## *Factors affecting toxic responses: disposition*

The disposition of a toxic compound in a biological system may be conveniently divided into four interrelated phases:

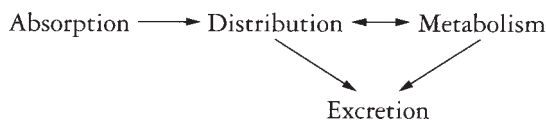

Each of these will be considered in turn.

### **3.1** *Absorption*

It is clear that to exert a toxic effect a compound must come into contact with the biological system under consideration. It may exert a local effect at the site of administration on initial exposure, but it must penetrate the organism in order to have a **systemic effect**. The most common means of entry for toxic compounds are via the gastrointestinal tract and the lungs, although in certain circumstances absorption through the skin may be an important route. Therapeutic

agents may also enter the body after administration by other routes.

#### **3.1.1 TRANSPORT ACROSS MEMBRANES**

Although there are several sites of first contact between a foreign compound and a biological system, the absorption phase (and also distribution and excretion) necessarily involves the passage across cell membranes whichever site is involved. Therefore it is important first to consider membrane structure and transport in order to understand the absorption of toxic compounds.

Membranes are basically composed of phospholipids and proteins with the lipids arranged as a bilayer interspersed with proteins as shown simply in figure 3.1. A more detailed illustration is to be found in figure 3.2 which shows that the membrane, on average about 70 Å (7 nm) thick, is not symmetrical and that there are different types of phospholipids and proteins as indicated in the figure. Furthermore carbohydrates, attached to proteins (glycoproteins) and

## *Factors affecting toxic responses: metabolism*

### 4.1 Introduction

As discussed in the preceding chapter, foreign and potentially toxic compounds absorbed into biological systems are generally lipophilic substances. They are therefore not ideally suited to excretion as they will be reabsorbed in the kidney or from the gastrointestinal tract after biliary excretion. For example, highly lipophilic substances such as polybrominated biphenyls and DDT are poorly excreted and therefore may remain in the animal's body for years.

The **biotransformation** of foreign compounds, however, attempts to convert such lipophilic substances into more polar, and consequently more readily excreted metabolites. The exposure of the body to the compound is hence reduced and potential toxicity decreased. This process of biotransformation is therefore a crucial aspect of the disposition of a toxic compound *in vivo*. Furthermore, as will become apparent later in the book, bi-

otransformation may also underlie the toxicity of a compound.

The metabolic fate of a compound can therefore have an important bearing on its toxic potential, disposition in the body and eventual excretion.

The primary results of biotransformation are therefore:

- 1 the parent molecule is transformed into a more polar metabolite, often by the addition of ionizable groups
- 2 molecular weight and size are often increased
- 3 the excretion is facilitated, and hence elimination of the compound from the tissues and the body is increased.

The consequences of metabolism are:

- a the biological half-life is decreased
- b the duration of exposure is reduced
- c accumulation of the compound in the body is avoided

---

## *Factors affecting metabolism and disposition*

---

---

### **5.1** *Introduction*

---

In the preceding two chapters, the disposition and metabolism of foreign compounds, as determinants of their toxic responses, were discussed. In this chapter, the influence of various chemical and biological factors on these determinants will be considered.

It is becoming increasingly apparent that the toxicity of a foreign compound and its mode of expression are dependent on many variables. Apart from large variations in susceptibility between species, within the same species many factors may be involved. The genetic constitution of a particular organism is known to be a major factor in conferring susceptibility to toxicity in some cases. The age of the animal and certain characteristics of its organ systems may also be important internal factors.

External factors such as the dose of the compound or the manner in which it is given, the diet of the animal and other foreign compounds to which it is exposed, are also important for the eventual toxic response. Although some of these factors may be controlled in experimental animals, in the human population they remain and may be extremely important.

For a logical use of experimental animals as models for man in toxicity testing, therefore, these factors must be appreciated and utilized for the fullest possible exploration of potential toxicity.

The factors affecting the disposition and toxicity of a foreign compound may be divided into chemical and biological factors:

*Chemical factors:* lipophilicity, size, structure,  $pK_a$ , ionization, chirality. *Biological factors:* species, strain, sex, genetic factors, disease and pathological

## *Toxic responses to foreign compounds*

### 6.1 *Introduction*

There are many ways in which an organism may respond to a toxic compound, and the type of response depends upon numerous factors. Although many of the toxic effects of foreign compounds have a biochemical basis, the expression of the effects may be very different. Thus, the development of tumours may be one result of an attack on nucleic acids, another might be the birth of an abnormal offspring. The interaction of a toxic compound with normal metabolic processes may cause a physiological response such as muscle paralysis, or a fall in blood pressure, or it may cause a tissue lesion in one organ. The covalent interaction between a toxic foreign compound and a normal body protein may in some circumstances cause an immunological response, in others a tissue lesion.

Thus, although all these toxic responses may have a biochemical basis, they have been categorized according to the manifestation of the

toxic effect. Therefore although there will be overlap between some of the types of toxic response, for the purposes of this discussion it is convenient to divide them into the following:

- i direct toxic action: tissue lesions
- ii pharmacological, physiological and biochemical effects
- iii teratogenesis
- iv immunotoxicity
- v mutagenesis
- vi carcinogenesis.

Toxic responses may be detected in a variety of ways in animals and some of these have already been alluded to in previous chapters. Toxic responses may be the **all-or-none type** such as the death of the organism or they may be **graded responses**. Thus the main means of detection are:

- a Death: the LD<sub>50</sub> assay has been utilized as an indicator of toxicity although it will be increasingly superseded by other assays;

---

## *Biochemical mechanisms of toxicity: specific examples*

---

---

### **7.1** *Chemical carcinogenesis*

---

#### **7.1.1 ACETYLAMINOFLUORENE**

This compound is a well known carcinogen and one of the most widely studied, and therefore this discussion must confine itself to the principles rather than details.

The study of acetylaminofluorene carcinogenicity has provided insight into the carcinogenicity of other aromatic amines and also illustrates a number of other important points. Acetylaminofluorene is a very potent mutagen and a carcinogen in a number of animal species, causing tumours primarily of the liver, bladder and the kidney. It became clear from the research that metabolism of the compound was involved in the carcinogenicity. The important metabolic reaction was found to be *N*-hydroxylation, catalysed by the microsomal mixed function oxidases, and this was demon-

strated both *in vitro* and *in vivo*. Thus *N*-hydroxyacetylaminofluorene (figure 7.1), the product, is a more potent carcinogen than the parent compound. The production of this metabolite *in vivo* was found to be increased nine-fold by the repeated administration of the parent compound, a finding of particular importance when considering the general use of single-dose rather than multiple low-dose studies for evaluating the toxicity of compounds. This effect is presumably the result of induction of the microsomal enzymes involved in the production of *N*-hydroxyacetylaminofluorene. *N*-hydroxylation has since proved to be an important metabolic reaction in the toxicity of a number of other compounds. The *N*-hydroxy intermediate in particular is of importance for the carcinogenicity of a number of aromatic amino, nitro and nitroso compounds. This intermediate may arise by reduction as well as oxidation (see page 90). However, *N*-hydroxyacetylaminofluorene is not the ultimate carcinogen, as it requires further metabolism in

A THEORETICAL BOOK ON  
**PHARMACEUTICAL**  
**BIOCHEMISTRY**

---

Edited by

**DR.M.VIJAY**



978-93-6255-107-8



A Theoretical Book on Pharmaceutical Biochemistry

Copyright © 2018 by Dr.M.Vijay

All rights reserved. No part of this book may be reproduced or transmitted in any form or by any means without written permission from the author.

**ISBN: 978-93-6255-107-8**



Publisher: Ponnaiyah Ramajayam Institute of Science and  
Technology (PRIST)

# TABLE OF CONTENTS

---

---

<b>Chapter 1</b> Pharmaceuticals, biologics and biopharmaceuticals	<b>Dr. M. VIJAY</b>	<b>1</b>
<b>Chapter 2</b> The drug development process	<b>Dr. BINUGEOGE</b>	<b>21</b>
<b>Chapter 3</b> The drug manufacturing process	<b>Dr. S. SATHISHKUMAR</b>	<b>35</b>
<b>Chapter 4</b> The cytokines — the interferon family	<b>Dr. A. SUNDARESAN</b>	<b>48</b>
<b>Chapter 5</b> Cytokines: interleukins and tumour necrosis factor	<b>Dr. G. SRITHAR</b>	<b>59</b>
<b>Chapter 6</b> Haemopoietic growth factors	<b>Dr. T. GUNASEELAN</b>	<b>74</b>
<b>Chapter 7</b> Growth factors	<b>Mr. R. Viswalingam</b>	<b>88</b>

=====

# Chapter 1

## Pharmaceuticals, biologics and biopharmaceuticals

### INTRODUCTION TO PHARMACEUTICAL PRODUCTS

Pharmaceutical substances form the backbone of modern medicinal therapy. Most traditional pharmaceuticals are low molecular mass organic chemicals (Table 1.1). Although some (e.g. aspirin) were originally isolated from biological sources, most are now manufactured by direct chemical synthesis. Two types of manufacturing companies thus comprise the 'traditional' pharmaceutical sector; the chemical synthesis plants, which manufacture the raw chemical ingredients in bulk quantities, and the finished product pharmaceutical facilities, which purchase these raw bulk ingredients, formulate them into final pharmaceutical products, and supply these products to the end-user.

In addition to chemical-based drugs, a range of pharmaceutical substances (e.g. hormones and blood products) are produced by or extracted from biological sources. Such products, some major examples of which are listed in Table 1.2, may thus be described as products of biotechnology. In some instances, categorizing pharmaceuticals as products of biotechnology or chemical synthesis becomes somewhat artificial, e.g. certain semi-synthetic antibiotics are produced by chemical modification of natural antibiotics produced by fermentation technology.

### BIOPHARMACEUTICALS AND PHARMACEUTICAL BIOTECHNOLOGY

Terms such as 'biologic', 'biopharmaceutical' and 'products of pharmaceutical biotechnology' or 'biotechnology medicines' have now become an accepted part of the pharmaceutical literature. However, these terms are sometimes used interchangeably and can mean different things to different people.

While it might be assumed that 'biologic' refers to any pharmaceutical product produced by biotechnological endeavour, its definition is more limited. In pharmaceutical circles, 'biologic'

# Chapter 2

## The drug development process

In this chapter, the life history of a successful drug will be outlined (summarized in Figure 2.1). A number of different strategies are adopted by the pharmaceutical industry in their efforts to identify new drug products. These approaches range from random screening of a wide range of biological materials to knowledge-based drug identification. Once a potential new drug has been identified, it is then subjected to a range of tests (both *in vitro* and in animals) in order to characterize it in terms of its likely safety and effectiveness in treating its target disease.

After completing such pre-clinical trials, the developing company apply to the appropriate government-appointed agency (e.g. the FDA in the USA) for approval to commence clinical trials (i.e. to test the drug in humans). Clinical trials are required to prove that the drug is safe and effective when administered to human patients, and these trials may take 5 years or more to complete. Once the drug has been characterized, and perhaps early clinical work is under way, the drug is normally patented by the developing company, in order to ensure that it receives maximal commercial benefit from the discovery.

Upon completion of clinical trials, the developing company collates all the pre-clinical and clinical data they have generated, as well as additional pertinent information, e.g. details of the exact production process used to make the drug. They submit this information as a dossier (a multi-volume work) to the regulatory authorities. Regulatory scientific officers then assess the information provided and decide (largely on criteria of drug safety and efficacy) whether the drug should be approved for general medical use.

If marketing approval is granted, the company can sell the product from then on. As the drug has been patented, they will have no competition for a number of years at least. However, in order to sell the product, a manufacturing facility is required, and the company will also have to gain manufacturing approval from the regulatory authorities. In order to gain a manufacturing licence, a regulatory inspector will review the proposed manufacturing facility. The regulatory authority will only grant the company a manufacturing licence if they are satisfied that every aspect of the manufacturing process is conducive to consistently producing a safe and effective product.

Regulatory involvement does not end even at this point. Post-marketing surveillance is generally undertaken, with the company being obliged to report any subsequent drug-induced side effects/adverse reactions. The regulatory authority will also inspect the manufacturing facility from time to time in order to ensure that satisfactory manufacturing standards are maintained.

# Chapter 3

## The drug manufacturing process

The manufacture of pharmaceutical substances is one of the most highly regulated and rigorously controlled manufacturing processes known. In order to gain a manufacturing licence, the producer must prove to the regulatory authorities that not only is the product itself safe and effective, but that all aspects of the proposed manufacturing process comply to the highest safety and quality standards. Various elements contribute to the safe manufacture of quality pharmaceutical products. These include:

- the design and layout of the manufacturing facility;
- raw materials utilized in the manufacturing process;
- the manufacturing process itself;
- the training and commitment of personnel involved in all aspects of the manufacturing operation;
- the existence of a regulatory framework which assures the establishment and maintenance of the highest quality standards with regard to all aspects of manufacturing.

This chapter aims to overview the manufacturing process. It concerns itself with four major themes: (a) a description of the infrastructure of a typical manufacturing facility, and some relevant operational issues—much of the detail presented in this section is equally applicable to facilities manufacturing non-biological-based pharmaceutical products; (b) sources of biopharmaceuticals; (c) upstream and downstream processing of biopharmaceutical products; and (d) analysis of the final biopharmaceutical product. Before delving into specific aspects of pharmaceutical manufacturing, various publications, such as international pharmacopoeias and guides to good manufacturing practice for medicinal products, will be discussed. These publications play a central role in establishing criteria which guarantee the consistent production of safe and effective drugs.

### INTERNATIONAL PHARMACOPOEIA

Many thousands of pharmaceutical substances are routinely manufactured by the pharmaceutical industry. Two of the most important determinants of final product safety and efficacy are: (a) the standard of raw materials used in the manufacturing process; and (b) the standard (i.e. specification) to which the final product is manufactured. Most pharmaceutical substances are

# Chapter 4

## The cytokines — the interferon family

### CYTOKINES

Cytokines are a diverse group of regulatory proteins or glycoproteins whose classification remains somewhat confusing, (Table 4.1). These molecules are normally produced in minute quantities by the body. They act as chemical communicators between various cells, inducing their effect by binding to specific cell surface receptors, thereby triggering various intracellular signal transduction events.

Most cytokines act upon or are produced by leukocytes (white blood cells), which constitute the immune and inflammatory systems (Box 4.1). They thus play a central role in regulating both immune and inflammatory function and related processes, such as haematopoiesis (the production of blood cells from haematopoietic stem cells in the adult bone marrow) and wound healing. Indeed, several immunosuppressive and anti-inflammatory drugs are now known to induce their biological effects by regulating the production of several cytokines.

The term 'cytokine' was first introduced in the mid-1970s. It was applied to polypeptide growth factors controlling the differentiation and regulation of cells of the immune system. The interferons (IFNs) and interleukins (ILs) represented the major polypeptide families classified as cytokines at that time. Additional classification terms were also introduced, including; lymphokines [cytokines such as interleukin-2 (IL-2) and interferon- $\gamma$  (IFN- $\gamma$ ), produced by lymphocytes] and monokines [cytokines such as tumour necrosis factor- $\alpha$  (TNF- $\alpha$ ) produced by monocytes]. However, classification on the basis of producing cell types also proved inappropriate, as most cytokines are produced by a range of cell types, e.g. both lymphocytes and monocytes produce IFN- $\alpha$ .

Initial classification of some cytokines was also undertaken on the basis of the specific biological activity by which the cytokine was first discovered, e.g. TNF exhibited cytotoxic effects on some cancer cell lines, colony stimulating factors (CSFs) promoted the growth *in vitro* of various leukocytes in clumps or colonies. This, too, proved an unsatisfactory classification mechanism, as it was subsequently shown that most cytokines display a range of biological

# Chapter 5

## Cytokines: interleukins and tumour necrosis factor

The interleukins (ILs) represent another large family of cytokines, with at least 25 different constituent members (IL-1 to IL-25) having been characterized thus far. Most of these polypeptide regulatory factors are glycosylated (a notable exception being IL-1) and display a molecular mass in the range 15–30 kDa. A few interleukins display a higher molecular mass, e.g. the heavily glycosylated, 40 kDa, IL-9.

Most of the interleukins are produced by a number of different cell types. At least 17 different cell types are capable of producing IL-1 (see Table 5.5), while IL-8 is produced by at least 10 distinct cell types. On the other hand, IL-2, -9 and -13 are produced only by T lymphocytes.

Most cells capable of synthesizing one IL are capable of synthesizing several, and many prominent producers of ILs are non-immune system cells (Table 5.1). Regulation of IL synthesis is exceedingly complex and only partially understood. In most instances, induction or repression of any one IL is prompted by numerous regulators—mostly additional cytokines, e.g. IL-1 promotes increased synthesis and release of IL-2 from activated T lymphocytes. It is highly unlikely that cells capable of synthesizing multiple ILs concurrently synthesize them all at high levels.

Nearly all ILs are soluble molecules (one form of IL-1 is cell-associated). They promote their biological response by binding to specific receptors on the surface of target cells. Most ILs exhibit paracrine activity (i.e. the target cells are in the immediate vicinity of the producer cells), while some display autocrine activity (e.g. IL-2 can stimulate the growth and differentiation of the cells that produce it). Other ILs display more systematic endocrine effects (e.g. some activities of IL-1).

The signal transduction mechanisms by which most ILs prompt their biological response are understood, in outline at least. In many cases, receptor binding is associated with intracellular tyrosine phosphorylation events. In other cases, serine and threonine residues of specific intracellular substrates are also phosphorylated. For some ILs, receptor binding triggers alternative signal transduction events, including promoting an increase in intracellular calcium concentration or inducing the hydrolysis of phosphatidylethanolamine with release of diacyl glycerol.



# Chapter 6

## Haemopoietic growth factors

Blood consists of red and white cells which, along with platelets, are all suspended in plasma. All peripheral blood cells are derived from a single cell type: the stem cell (also known as a pluripotential, pluripotent or haemopoietic stem cell). These stem cells reside in the bone marrow, alongside additional cell types, including (marrow) stromal cells. Pluripotential stem cells have the capacity to undergo prolonged or indefinite self-renewal. They also have the potential to differentiate, thereby yielding the range of cells normally found in blood (Table 6.1). This process, by which a fraction of stem cells are continually 'deciding' to differentiate (thus continually producing new blood cells and platelets to replace aged cells), is known as haemopoiesis.

The study of the process of haemopoiesis is rendered difficult by the fact that it is extremely difficult to distinguish or separate individual stem cells from their products during the earlier stages of differentiation. However, a picture of the process of differentiation is now beginning to emerge (Figure 6.1). During the haemopoietic process, the stem cells differentiate, producing cells that become progressively more restricted in their choice of developmental options.

The production of many mature blood cells begins when a fraction of the stem cells differentiate, forming a specific cell type termed CFU-S (CFU refers to colony forming unit). These, in turn, differentiate yielding CFU-GEMM cells, a mixed CFU which has the potential to differentiate into a range of mature blood cell types, including granulocytes, monocytes, erythrocytes, platelets, eosinophils and basophils. Note that lymphocytes are not derived from the CFU-GEMM pathway, but differentiate via an alternative pathway from stem cells (Figure 6.1).

The details of haemopoiesis presented thus far prompt two very important questions. How is the correct balance between stem cell self-renewal and differentiation maintained? And what forces exist that regulate the process of differentiation? The answer to both questions, in particular the latter, is beginning to emerge in the form of a group of cytokines termed 'haemopoietic growth factors' (Table 6.2). This group includes:

- several (of the previously described) interleukins (ILs) that primarily affect production and differentiation of lymphocytes;
- colony stimulating factors (CSFs), which play a major role in the differentiation of stem-derived cells into neutrophils, macrophages, megakaryocytes (from which platelets are derived), eosinophils and basophils;

# Chapter 7

## Growth factors

The growth of eukaryotic cells is modulated by various influences, of which growth factors are amongst the most important for many cell types. A wide range of polypeptide growth factors have been identified (Table 7.1) and more undoubtedly remain to be characterized. Factors that inhibit cell growth also exist, e.g. interferons (IFNs) and tumour necrosis factor (TNF) inhibit proliferation of various cell types.

Some growth factors may be classified as cytokines, e.g. ILs, transforming growth factor- $\beta$  (TGF- $\beta$ ) and colony stimulating factors (CSFs). Others, e.g. insulin-like growth factors (IGFs) are not members of this family. Each growth factor has a mitogenic (promotes cell division) effect on a characteristic range of cells. While some such factors affect only a few cell types, most stimulate the growth of a wide range of cells. The range of growth factors considered in this chapter is limited to those that have not received attention in previous chapters.

The ability of such factors to promote accelerated cellular growth and division has predictably attracted the attention of the pharmaceutical industry. The clinical potential of a range of such factors, e.g. to accelerate the wound-healing process, is currently being assessed in various clinical trials (Table 7.2).

### GROWTH FACTORS AND WOUND HEALING

The wound-healing process is complex and as yet not fully understood. The area of tissue damage becomes the focus of various events, often beginning with immunological and inflammatory reactions. The various cells involved in such processes, as well as additional cells at the site of the wound, also secrete various growth factors. These mitogens stimulate the growth and activation of various cell types, including fibroblasts (which produce collagen and elastin precursors, and ground substance), epithelial cells (e.g. skin cells) and vascular endothelial cells. Such cells advance healing by promoting processes such as granulation (growth of connective tissue and small blood vessels at the healing surface) and subsequent epithelialization. The growth factors that appear most significant to this process include fibroblast growth factors (FGFs), transforming growth factors (TGFs), platelet-derived growth factor (PDGF), insulin-like growth factor 1 (IGF-1) and epidermal growth factor (EGF).

Wounds can be categorized as acute (healing quickly on their own) or chronic (healing slowly, and often requiring medication). Chronic wounds, such as ulcers (Table 7.3), occur if some

# RESEARCH METHODOLOGY

Edited by  
**DR.R.KALPANA**



978-93-6255-262-4

# **Research methodology**

Copyright © 2018 by Dr.R.Kalpana

First Edition,2018

*All rights reserved. No part of this book may be reproduced or transmitted in any form or by any means without written permission from the author.*

**ISBN: 978-93-6255-262-4**

***Publisher:*** Ponnaiyah Ramajayam Institute of Science and Technology (**PRIST**)

## TABLE OF CONTENTS

<b>Book elements</b>	<b>Page Numbers</b>
----- <b>Chapter-I</b> <i>Introduction To Research Methodology</i> Dr.R.Kalpana	<b>01-10</b>
----- <b>Chapter-II</b> <i>Database and literature survey</i> Dr.R.Kalpana	<b>11-14</b>
----- <b>Chapter-III</b> <i>Thesis and paper writing</i> Dr.R.Kalpana	<b>15-20</b>
----- <b>Chapter-IV</b> <i>Application of MATLAB</i> Dr.R.Kalpana	<b>21-26</b>
----- <b>Chapter-V</b> <i>Data analysis</i> Dr.R.Kalpana	<b>27-33</b>
-----	

# INTRODUCTION TO RESEARCH METHODOLOGY

**Dr.R.Kalpana**

*Asst. Professor in Mathematics*

*Ponnaiyah Ramajayam Institute of Science and Technology (PRIST)*

*Vallam, Thanjavur, Tamilnadu, South India.*

## Introduction

Research methodology is a term that basically means the science of how research is done scientifically. It is a way to systematically and logically solve a problem, help us understand the process not just the product of research, and analyzes methods in addition to the information obtained by them.

## What are the types of research methodology?

- ↳ Basic research
- ↳ Applied Research
- ↳ Problem oriented research
- ↳ Problem solving
- ↳ Quantitative Research
- ↳ Qualitative Research

## Research Problem:

A research problem is a statement about an area of concern, a condition to be improved, a difficulty to be eliminated, or a troubling question that exists in scholarly literature, in theory, or in practice that points to the need for meaningful understanding and deliberate investigation.

## Research problem statement

A problem statement is the description of an issue currently existing which needs to be addressed. It provides the context for the research study and generates the

questions which the research aims to answer. The statement of the problem is the focal point of any research.

### **Identify the problem**

Here are seven-steps for an effective problem-solving process.

1. Identify the issues. Be clear about what the problem is.
2. Understand everyone's interests.
3. List the possible solutions (options).
4. Evaluate the options.
5. Select an option or options.
6. Document the agreement(s).
7. Agree on contingencies, monitoring, and evaluation.

### **Necessity of Defining a Research Problem:**

The problem to be researched needs to be described unambiguously as that will help you to discriminate useful data from the unrelated ones. A proper formulation of research problem will allow the investigator to be on the track in contrast to an ill-defined problem may possibly create difficulties.

Questions like: What data are to be gathered? What attributes of data are appropriate and need to be analyzed? What relations should be investigated. What methods should be employed for the purpose? as well as other questions turn up in the head of the investigator who can well plan his strategy and find solutions to these kinds of questions only when the research problem has been well defined. Therefore, defining the problem accurately is a necessity for any research and is a step of the highest value.

In fact, formulation of a problem is often vital than its solution. It is only on thoroughly describing the problem that we can work out the research design and can efficiently proceed all the consequential steps needed while doing research.



### **Important Points to Keep in Mind while Defining the Research Problem**

1. The correct question needs to be addressed if research is to help decision makers. A right answer to the wrong question leads either to bad advice or to no advice.
2. Usually in problem we have an inclination to rationalize and defend our actions once we have started upon a specific research plan. The perfect time to examine and think about alternative techniques is in the planning stage. If it is completed unnecessary expense of false start and redoing work may be prevented.
3. An excellent beginning in problem definition is to ask what the decision maker want to know if the requested information can be gathered without error and without expense.
4. Another excellent rule to follow is “Never settle on a specific strategy” without developing and taking into consideration at least one alternate option”.
5. The problem definition stage of research is the determination and structuring of the decision maker’s question. It should be the decision maker’s question and not the researcher’s question.
6. What decision do you face? Unless you have decision to make, there isn’t any research problem.
7. What are the alternatives? In case there are no options to choose, once again there is absolutely no research problem.
8. What are the factors for selecting the best alternative? Unless you have criteria for evaluation, again there’s no problem.
9. The researcher should stay away from the acceptance of the superficial and the obvious. Frequently we all hear that a problem clearly expressed is a problem half solved.

This statement indicates the necessity of defining a research problem in research methodology .This actually also results in a smoother progress on all the following steps which are needed for finishing a research project.

### **Types of Research:**

There are different types of research. The basic ones are as follows.

## **Descriptive**

Versus Analytical: Descriptive research consists of surveys and fact-finding enquiries of different types. The main objective of descriptive research is describing the state of affairs as it prevails at the time of study. The term 'ex post facto research' is quite often used for descriptive research studies in social sciences and business research. The most distinguishing feature of this method is that the researcher has no control over the variables here. He/she has to only report what is happening or what has happened. Majority of the ex post facto research projects are used for descriptive studies in which the researcher attempts to examine phenomena, such as the consumers' preferences, frequency of purchases, shopping, etc. Despite the inability of the researchers to control the variables, ex post facto studies may also comprise attempts by them to discover the causes of the selected problem. The methods of research adopted in conducting descriptive research are survey methods of all kinds, including correlational and comparative methods.

Meanwhile in the Analytical research, the researcher has to use the already available facts or information, and analyze them to make a critical evaluation of the subject.

## **Applied Versus Fundamental:**

Research can also be applied or fundamental in nature. An attempt to find a solution to an immediate problem encountered by a firm, an industry, a business organization, or the society is known as applied research. Researchers engaged in such researches aim at drawing certain conclusions confronting a concrete social or business problem

On the other hand, fundamental research mainly concerns generalizations and formulation of a theory. In other words, "Gathering knowledge for knowledge's sake is termed 'pure' or 'basic' research" (Young in Kothari, 1988). Researches relating to pure mathematics or concerning some natural phenomenon are instances of

Fundamental Research. Likewise, studies focusing on human behaviour also fall under the category of fundamental research.

Thus, while the principal objective of applied research is to find a solution to some pressing practical problem, the objective of basic research is to find information with a broad base of application and add to the already existing organized body of scientific knowledge.

### **Quantitative Versus Qualitative:**

Quantitative research relates to aspects that can be quantified or can be expressed in terms of quantity. It involves the measurement of quantity or amount. Various available statistical and econometric methods are adopted for analysis in such research. Which includes correlation, regressions and time series analysis etc.,.

On the other hand, Qualitative research is concerned with qualitative phenomena, or more specifically, the aspects related to or involving quality or kind. For example, an important type of qualitative research is 'Motivation Research', which investigates into the reasons for certain human behaviour. The main aim of this type of research is discovering the underlying motives and desires of human beings by using in-depth interviews. The other techniques employed in such research are story completion tests, sentence completion tests, word association tests, and other similar projective methods. Qualitative research is particularly significant in the context of behavioural sciences, which aim at discovering the underlying motives of human behaviour. Such research helps to analyse the various factors that motivate human beings to behave in a certain manner, besides contributing to an understanding of what makes individuals like or dislike a particular thing. However, it is worth noting that conducting qualitative research in practice is considerably a difficult task. Hence, while undertaking such research, seeking guidance from experienced expert researchers is important.

### **Conceptual Versus Empirical:**

The research related to some abstract idea or theory is known as Conceptual Research. Generally, philosophers and thinkers use it for developing new concepts or for reinterpreting the existing ones. Empirical Research, on the other hand, exclusively relies on the observation or experience with hardly any regard for theory and system. Such research is data based, which often comes up with conclusions that can be verified through experiments or observation. Empirical research is also known as experimental type of research, in which it is important to first collect the facts and their sources, and actively take steps to stimulate the production of desired information. In this type of research, the researcher first formulates a working hypothesis, and then gathers sufficient facts to prove or disprove the stated hypothesis. He/she formulates the experimental design, which according to him/her would manipulate the variables, so as to obtain the desired information. This type of research is thus characterized by the researcher's control over the variables under study. In simple terms, empirical research is most appropriate when an attempt is made to prove that certain variables influence the other variables in some way. Therefore, the results obtained by using the experimental or empirical studies are considered to be the most powerful evidences for a given hypothesis.

### **Other Types of Research:**

The remaining types of research are variations of one or more type of research. They vary in terms of the purpose of research, or the time required to complete it, or may be based on some other similar factor. On the basis of time, research may either be in the nature of one-time or longitudinal time series research. While the research is restricted to a single time-period in the former case, it is conducted over several time-periods in the latter case. Depending upon the environment in which the research is to be conducted, it can also be laboratory research or field-setting research, or simulation research, besides being diagnostic or clinical in nature. Under such research, in-depth approaches or case study method may be employed to analyse the basic causal relations. These studies usually undertake a detailed in-depth analysis of the causes of certain events of interest, and use very small samples and sharp data

collection methods. The research may also be explanatory in nature. Formalized research studies consist of substantial structure and specific hypotheses to be verified. As regards to historical research, sources like historical documents, remains, etc. Are utilized to study past events or ideas. It also includes philosophy of persons and groups of the past or any remote point of time.

Research has also been classified into decision-oriented and conclusion-oriented categories. The decision-oriented research is always carried out as per the need of a decision maker and hence, the researcher has no freedom to conduct the research according to his/her own desires. On the other hand, in the case of Conclusion-oriented research, the researcher is free to choose the problem, redesign the enquiry as it progresses and even change conceptualization as he/she wishes to. An operation research is a kind of decision-oriented research, where in scientific method is used in providing the departments, a quantitative basis for decision -making with respect to the activities under their purview.

Steps in Research Process Research process contains a series of closely related activities which has to carry out by a researcher. Research process requires patients. There is no measure that shows your research is the best. It is an art rather than a science. Following are the main steps in social or business research process.

1. Selection of Research Problem
2. Extensive Literature Survey
3. Making Hypothesis
4. Preparing the Research Design
5. Sampling 6. Data collection
7. Data Analysis
8. Hypothesis Testing
9. Generalization and Interpretation
10. Preparation of Report

### **Selection of Research Problem:**

The selection of topic for research is a difficult job. When we select a title or research statement, then other activities would be easy to perform. So, for the understanding thoroughly the problem it must have to discuss with colleagues, friend, experts and teachers. The research topic or problem should be practical, relatively important, feasible, ethically and politically acceptable.

### **Literature Review or Extensive Literature Survey**

After the selection of research problem, the second step is that of literature mostly connected with the topics. The availability of the literature may bring ease in the research. For this purpose academic journals, conference and govt. reports and library must be studied

### **Making Hypothesis**

The development of hypothesis is a technical work depends on the researcher experience. The hypothesis is to draw the positive & negative cause and effect aspects of a problem. Hypothesis narrows down the area of a research and keep a researcher on the right path

### **Preparing the Research Design**

After the formulation of the problem and creating hypothesis for it, research Design is to prepare by the researcher. It may draw the conceptual structure of the problem. Any type of research design may be made, depend on the nature and purpose of the study. During R. Design the information about sources, skill, time and finance is taken into consideration.

### **Sampling**

The researcher must design a sample. It is a plan for taking its respondents from a specific areas or universe.

The sample may be of two types:

1. Probability Sampling

## 2. Non-probability Sampling

### **Data collection**

Data collection is the most important work, is researcher. The collection of information must be containing on facts which is from the following two types of researcher.

#### **Primary Data Collection:**

Primary data may be from the following.

1. Experiment
2. Questionnaire
3. Observation
4. Interview

#### **Secondary data collection:**

It has the following categories:

1. Review of literature
2. Official and non-official reports
3. Library approach

### **Data Analysis**

When data is collected, it is forwarded for analysis which is the most technical job. Data analysis may be divided into two main categories.

**Data Processing:** it is sub-divided into the following

Data editing, Data coding, Data classification, Data tabulation, Data presentation, Data measurement

**Data Exposition:** Date Exposition has the following

sub-categories. Description, Explanation, Narration, Conclusion/Findings, Recommendations/Suggestions



## **Hypothesis Testing**

Research data is then forwarded to test the hypothesis. Do the hypothesis are related to the f acts or not? To find the answer the process of testing hypothesis is undertaken which may result in accepting or rejecting the hypothesis

## **Generalization and Interpretation:**

The acceptable hypothesis is possible for researcher to arrival at the process of generalization or to make & theory. Some types of research has no hypothesis for which researcher depends upon on theory which is known as interpretation.

### DATABASE AND LITERATURE SURVEY

**Dr.R.Kalpana**

*Asst. Professor in Mathematics*

*Ponnaiyah Ramajayam Institute of Science and Technology (PRIST)*

*Vallam, Thanjavur, Tamilnadu, South India.*

#### **The Literature Search**

- A systematic review search includes a search of databases, gray literature, personal communications, and a hand search of high impact journals in the related field. See our list of recommended databases and gray literature sources on this page.
- a comprehensive literature search cannot be dependent on a single database, nor on bibliographic databases only.
- inclusion of multiple databases helps avoid publication bias (geographic bias or bias against publication of negative results).
- The Cochrane Collaboration recommends PubMed, Embase and the Cochrane Central Register of Controlled Trials (CENTRAL) at a minimum.
- **NOTE:** The Cochrane Collaboration and the IOM recommend that the literature search be conducted by librarians or persons with extensive literature search experience. Please contact the NIH Librarians for assistance with the literature search component of your systematic review.

#### **Databases**

- **Cochrane Library**

A collection of six databases that contain different types of high-quality, independent evidence to inform healthcare decision-making. Search the Cochrane Central Register of Controlled Trials here.

- **Embase**

European database of biomedical and pharmacologic literature.

- **PubMed**

PubMed comprises more than 21 million citations for biomedical literature from MEDLINE, life science journals, and online books.

- **Scopus**

Largest abstract and citation database of peer-reviewed literature and quality web sources. Contains conference papers.

- **Web of Science**

World's leading citation databases. Covers over 12,000 of the highest impact journals worldwide, including Open Access journals and over 150,000 conference proceedings. Coverage in the sciences, social sciences, arts, and humanities, with coverage to 1900.

### **Subject Specific Databases**

- **APA PsycINFO**

Over 4.5 million abstracts of peer-reviewed literature in the behavioral and social sciences. Includes conference papers, book chapters, psychological tests, scales and measurement tools.

- **CINAHL Plus**

Comprehensive journal index to nursing and allied health literature, includes books, nursing dissertations, conference proceedings, practice standards and book chapters.

- **LILACS**

Latin American and Caribbean health sciences literature database

### **Gray Literature**

- *Gray Literature* is the term for information that falls outside the mainstream of published journal and monograph literature, not controlled by commercial publishers

- includes:

- hard to find studies, reports, or dissertations

- conference abstracts or papers
  - governmental or private sector research
  - clinical trials - ongoing or unpublished
  - experts and researchers in the field
- ***Gray Literature Sources***
    - Library catalogs
    - Professional association websites
    - WorldCat - 1.5 billion items in this collection of library catalogs
      - Google Scholar - Search scholarly literature across many disciplines and sources, including theses, books, abstracts and articles.
    - Dissertation Abstracts - dissertation and theses database - NIH Library biomedical librarians can access and search for you.
    - NTIS - central resource for government-funded scientific, technical, engineering, and business related information.
    - AHRQ - agency for healthcare research and quality
    - Open Grey - system for information on grey literature in Europe. Open access to 700,000 references to the grey literature.
    - World Health Organization - providing leadership on global health matters, shaping the health research agenda, setting norms and standards, articulating evidence-based policy options, providing technical support to countries and monitoring and assessing health trends.
    - New York Academy of Medicine Grey Literature Report - a bimonthly publication of The New York Academy of Medicine (NYAM) alerting readers to new gray literature publications in health services research and selected public health topics. NOTE: Discontinued as of Jan 2017, but resources are still accessible.
    - Gray Source Index
    - Open DOAR - directory of academic repositories

- Clinical Trial Registries
  - International Clinical Trials Registry Platform - from the World Health Organization
  - Australian New Zealand Clinical Trials Registry
  - Brazilian Clinical Trials Registry
  - Chinese Clinical Trial Registry-
  - ClinicalTrials.gov - U.S. and international federally and privately supported clinical trials registry and results database
  - Clinical Trials Registry - India
  - EU clinical Trials Register
  - ISRCTN.org
  - Japan Primary Registries Network
  - Pan African Clinical Trials Registry

## THESIS AND PAPER WRITING

**Dr.R.Kalpana**

*Asst. Professor in Mathematics*

*Ponnaiyah Ramajayam Institute of Science and Technology (PRIST)*

*Vallam, Thanjavur, Tamilnadu, South India.*

### Steps you can use to create a thesis statement

1. Start out with the main topic and focus of your essay. ...
2. Make a claim or argument in one sentence. ...
3. Revise the sentence by using specific terms. ...
4. Further revise the sentence to cover the scope of your essay and make a strong statement.

### Example of a thesis in a research paper

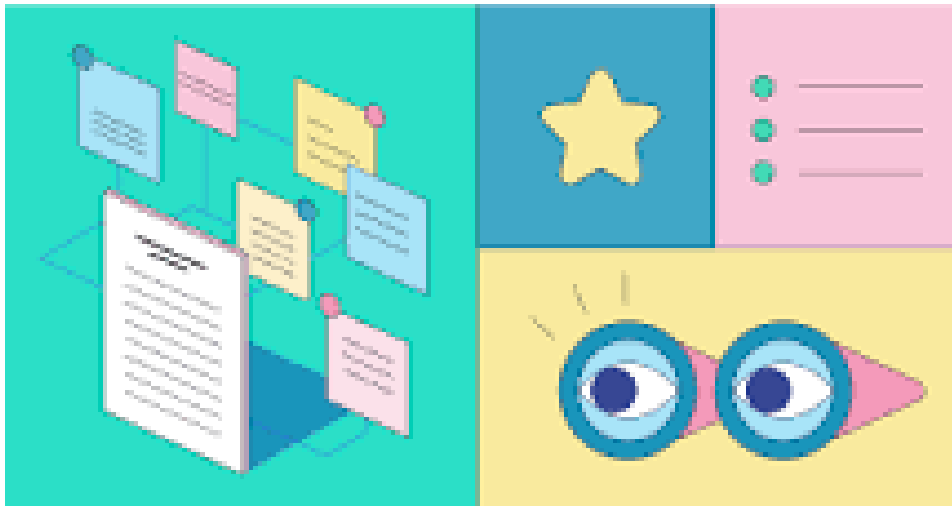

For example, if you were researching the effects of exercise on stress, your thesis statement might be: Due to the neurological effects of exercise, people who exercise regularly report lower stress levels than those who do not exercise.

### How to write a thesis research paper?





Developing a strong thesis statement involves starting with a research question, constructing a statement that addresses this question, supporting it with evidence and reasoning, and anticipating counterarguments. The statement should be original, clear, specific, and debatable.

### Example of a thesis in a research paper

Example of an expository (explanatory) thesis statement: The life of the typical college student is characterized by time spent studying, attending class, and socializing with peers. The paper that follows should: Explain how students spend their time studying, attending class, and socializing with peers.

### Thesis format

General Format. Standard Document Format refers to one thesis document that addresses a single theme. The Pretext Pages, Introduction, Conclusion, and Bibliography are mandatory. Your committee determines the additional chapters; you choose the chapter titles.

A thesis is a long research paper that you develop over the course of a research degree or academic position. Institutions and funding bodies view the thesis as the

main deliverable that an academic produces in return for funding and investment. As a result, the thesis serves as the main body of work you produce throughout the course of your research, though your other research papers may contribute to it. You may choose to publish your thesis or make it the basis for longer pieces of work later in your career. Institutions generally assign an expert in your field to supervise your writing.

The following steps explain how to write a thesis, focusing on the common steps that you're likely to follow regardless of your specialisation:

Regardless of your field or statement, it's important to conduct thorough research before committing anything to paper. Writing your thesis may take place after conducting your research, or it may be a gradual process of writing chapters as you research. In-depth research allows you to form your ideas and develop a clear argument while engaging with existing scholarship. After developing your idea, you can move on to writing.

### **Thesis structure**

As a starting point, plan your thesis' evidence and argument around your research proposal and findings. Decide how you want to support your argument and separate your evidence into self-contained but linked discussions. It's important to include sections for contextualising the history of scholarship, integrating your ideas into existing theories and addressing counterarguments. Look at key publications in your field to investigate how they typically look and what scholars expect from them.

### **Format**

Set up a working document for your thesis and make some basic decisions about the font, line spacing and referencing format. Making these decisions early can help you get in the right mindset and feel that you're making progress. Theses usually have a title page with the thesis title, your name, your supervisor's name and your institution and department. You can add other relevant details, such as the submission

date and your final title, at the end of the process, but creating your title page first can help you make a start and focus on writing.

### **Statement of Thesis**

A thesis statement explains the main argument you're presenting based on your research. Depending on the length of your thesis, you may state this at the end of your introduction or in its own dedicated section. Your statement can be explanatory, argumentative or analytical, depending on how much detail you want to go into before presenting your evidence. Make a clear statement that explains your stance on the issue, summarises the point of your research and briefly indicates how your evidence supports it.

### **Main body and arguments**

As you research and develop your ideas, write the main body of the thesis one section at a time. Trying to write your entire thesis at once is a challenging mental task, so dividing it into more achievable segments makes it more manageable. Making each section a self-contained discussion that contributes to the main statement can also help with reading comprehension. Remember to reiterate your main argument so that your writing is cohesive, but try to avoid unnecessary repetition.

### **Method and the history of Scholarship**

A good thesis makes a clear point based on evidence the writer has collected and contextualizes it in previous thought. Demonstrate a thorough awareness of existing scholarship and theories in a dedicated section or during other discussions. Criticize key publications where relevant and identify the scholars you disagree with by name. Discuss your methodological approaches in full and clarify how and why your evidence leads you to your main conclusions in relation to previous scholarship.

### **List of Indexes**

Add any relevant figures, images or supporting material to the thesis with references. A thesis usually has a contents page listing section titles and headings. Go

through your thesis and make sure to account for every section. Also, check that you haven't included sections or titles that you later cut from the final piece. Add an index that lists any figures, plates, tables and images in your thesis. It may also be beneficial to include an index of topics, names or key terms for readers to use for reference.

## **Conclusion**

The introduction and conclusion to your thesis serve similar purposes in introducing your thoughts and finalising your statements. Try to leave these until the end, since the body of your thesis is likely to change through many drafts throughout the course of writing it. A good introduction attracts the reader's attention, references past research, hints at the importance of your ideas and introduces your main thesis statement. A good conclusion consolidates your ideas, reiterates your thesis statement, examines its implications and encourages a discussion about future research and ideas.

## **Bibliography**

Add your references in whichever format is standard for your field, such as APA, Harvard or MLA. Include each source you refer to in your thesis. You may include a bibliography at the end of your thesis for any research sources you didn't refer to directly. Make sure to double-check that you have referenced each work you included and remove any orphaned footnotes that you deleted in the process of writing.

## **The final Sections**

Add any additional sections, such as an abstract, acknowledgements and appendices. Your acknowledgements thank contributors, supervisors, friends and colleagues who helped you to write the document. An abstract, which is usually fewer than 500 words, provide a summary of your thesis and is common in scientific and arts theses. If there's any material that isn't directly relevant to your main statement but adds valuable context, you can include it in an appendix. There may be a word count allowance for appendices, depending on your field and submission requirements.

## Proofread and submit of Thesis

Once your thesis is complete, read through it and check for any sections or passages you would like to rewrite. It's normal for thesis writers to have several drafts before submitting the final work, so don't be afraid to make changes. Once you're happy with it, proofread it to check for any spelling or grammatical errors. You may want to use grammar software or ask a friend or colleague for help. Check that it's formatted according to the guidelines and submit it for review and final publication.

## Tips

A good thesis usually contributes significantly to the field, engages critically with scholarship and demonstrates a clear personal style and confidence. Here are some common traits among good theses:

- **Clearly programmatic:** A good thesis contains a clear structure and method so the reader understands how each section contributes to the overall argument. Layout your arguments logically, reference previous scholarship and forecast each segment clearly so that readers can follow.
- **Confident stance:** Examining bodies value a thesis that engages with ongoing debates and puts forward a confident stance with supporting evidence. Commit to your stance and give compelling reasons for your arguments so that you contribute to ongoing debates.
- **Focused argument:** Focus your observations and evidence on your main argument and don't include unnecessary background information. Contextualise your points but focus on supporting your main thesis statements.
- **Summative conclusion:** A good thesis has a conclusion that thoroughly considers the evidence you've put forward and how it interacts with counterarguments. Form a confident and considered conclusion that encourages further questions and study.
- **Thought-provoking:** Make sure your thesis promotes further questioning and makes your reader think about the topic in detail. Encourage your readers to

approach the topic from a different angle and ask questions about why and how your thesis statement makes sense.

### Application of MATLAB

**Dr.R.Kalpana**

*Asst. Professor in Mathematics*

*Ponnaiyah Ramajayam Institute of Science and Technology (PRIST)*

*Vallam, Thanjavur, Tamilnadu, South India.*

#### Introduction



Millions of engineers and scientists worldwide use MATLAB for a range of applications, in industry and academia, including deep learning and machine learning, signal processing and communications, image and video processing, control systems, test and measurement, computational finance, and computational biology.

What is the application of MATLAB in the medical field?

With MATLAB, you can also use deep learning methods to perform semantic segmentation of brain tumors from 3D medical images. You can design and train neural networks or use pretrained networks. Segmented tumor in brain tissue using MATLAB with labeled ground truth (left) and network prediction (right).

**Introduction:** Mathematics is a fundamental field of study that has far-reaching applications in various industries and scientific fields. Over the years, mathematicians



have relied on computation tools to solve complex mathematical problems. MATLAB is one such tool that has been widely used in mathematical research. MATLAB is a high-level programming language that offers a flexible environment for numerical computation, data analysis, and visualization. This provides an overview of the application of MATLAB in mathematics, highlighting its importance in various fields of mathematics and its potential to revolutionize mathematical research. Matlab is a powerful tool for mathematical research in a variety of fields. Its extensive library of built-in functions and toolboxes allows researchers to quickly prototype algorithms, analyze data, and visualize results. Matlab also provides a flexible programming environment that enables researchers to implement their own algorithms and customize existing ones. One of the key advantages of using Matlab in mathematical research is its ability to handle large datasets and complex computations. This makes it a popular choice in fields such as statistics, machine learning, and computational biology, where researchers often work with large amounts of data. Matlab's powerful visualization tools also make it a valuable tool for researchers who need to visualize data and communicate their results. Matlab can produce high-quality 2D and 3D plots, as well as animations and interactive visualizations, which can be used to communicate complex mathematical concepts to a wider audience.

In addition, Matlab's active user community and extensive documentation make it easy for researchers to learn the language and get help when needed. This community also provides a wealth of user-created tools and scripts that can be used to streamline research workflows and improve productivity. Overall, Matlab is a valuable tool for mathematical research due to its flexibility, power, and ease of use. It can help researchers to quickly prototype and test algorithms, analyze large datasets, and visualize results in a way that is accessible to a wider audience

### **MATLAB in Linear Algebra:**

Linear algebra is a critical branch of mathematics that deals with the study of linear equations and their solutions. MATLAB provides a range of functions for performing linear algebraic computations. For example, the backslash operator in

MATLAB can be used to solve systems of linear equations, while the eigenvalue and eigenvector functions can be used to solve eigenvalue problems. MATLAB's built-in functions for matrix multiplication and inversion make it an excellent tool for performing complex computations in linear algebra

### **MATLAB in Calculus:**

MATLAB is a useful tool for solving complex problems in Calculus, which deals with the study of rates of change and accumulation. For example, MATLAB provides functions such as `quad` and `diff` that are essential for numerical integration and differentiation. These functions can be used to find the area under a curve or compute the derivative of a function, which are fundamental concepts in Calculus. With the help of MATLAB's tools for numerical integration and differentiation, researchers and students can solve calculus problems more efficiently and accurately.

### **MATLAB in Differential Equations:**

Differential equations are a class of mathematical equations that describe the relationship between a function and its derivatives. MATLAB provides a range of functions for solving differential equations, including the `ode45` and `ode23` functions. These functions are essential for solving complex differential equations that cannot be solved analytically. MATLAB's ability to handle large data sets makes it an excellent tool for solving complex systems of differential equations.

### **MATLAB in Laplace Transforms:**

MATLAB is a powerful tool for Laplace transform analysis and visualization. Laplace transform is a mathematical technique used to transform a time-domain signal into the frequency domain. This transformation can be useful for solving differential equations and analyzing systems with complex dynamics.

In MATLAB, the Laplace transform can be computed using the symbolic math toolbox or the control systems toolbox. The symbolic math toolbox provides a suite of functions for computing Laplace transforms, inverse Laplace transforms, and other

related operations. These functions can be used to perform Laplace transform analysis on symbolic expressions, functions, and differential equations. The control systems toolbox provides a set of functions for analyzing linear systems in the frequency domain. These functions can be used to compute the Laplace transform of a system transfer function and plot frequency response curves. The toolbox also includes functions for computing poles and zeros, stability analysis, and controller design.

MATLAB's visualization tools can also be used to plot Laplace transform functions and frequency response curves. The plot function can be used to plot Laplace transform functions in the complex plane, and the bode and Nyquist functions can be used to plot frequency response curves. Overall, Matlab provides a comprehensive suite of tools for Laplace transform analysis and visualization. Its symbolic math toolbox and control systems toolbox make it easy to compute Laplace transforms, analyze linear systems, and design controllers. Its powerful visualization tools make it easy to visualize Laplace transform functions and frequency response curves.

**MATLAB in Statistics:** Statistics is a critical branch of mathematics that deals with the study of data and probability. MATLAB provides a range of tools for performing statistical analysis, including the mean, median, and standard deviation functions. These functions are essential for analyzing data sets and performing hypothesis testing

#### **Advantages of using MATLAB in Mathematical Research:**

MATLAB provides several advantages over traditional methods of mathematical research. First, MATLAB is a user-friendly tool that is easy to learn and use, making it accessible to a wide range of users. Additionally, MATLAB can handle large data sets and perform complex numerical computations efficiently, making it an excellent tool for mathematical research. Moreover, MATLAB offers various visualization tools that allow researchers to visualize data and results, making it easier to communicate their findings effectively. Lastly, MATLAB provides a flexible

programming environment that enables researchers to customize existing algorithms or implement new ones, which is a significant advantage for mathematical research.

**MATLAB offers numerous advantages for mathematical research purposes.**

Some of these advantages include:

1. **Rapid Prototyping:** MATLAB offers a range of built-in functions and toolboxes that allow researchers to quickly prototype and test algorithms.
2. **Flexible Programming Environment:** MATLAB provides a flexible programming environment that enables researchers to implement their own algorithms and customize existing ones.
3. **Handling of Large Datasets:** MATLAB can handle large datasets and complex computations, making it suitable for statistical analysis, machine learning, and computational biology.
4. **Powerful Visualization Tools:** MATLAB's powerful visualization tools enable researchers to effectively communicate complex mathematical concepts.
5. **Active User Community:** MATLAB has an active user community and extensive documentation, making it easy to learn and get help when needed.
6. **Integration with Other Languages:** MATLAB is compatible with other languages and software, allowing for easy integration into research workflows.
7. Overall, MATLAB is a valuable tool for mathematical research purposes due to its flexibility, power, and ease of use

MATLAB is a powerful tool that has revolutionized the field of mathematics. Its ability to handle large data sets and perform complex numerical computations efficiently makes it an excellent tool for mathematical research. MATLAB's user-friendly environment and visualization tools make it accessible to a wide range of users, making it an essential tool in the field of mathematics. The future of MATLAB in mathematical research looks promising, with the potential to revolutionize the field and open up new avenues for research

**DATA ANALYSIS**

**Dr.R.Kalpana**

*Asst. Professor in Mathematics*

*Ponnaiyah Ramajayam Institute of Science and Technology (PRIST)*

*Vallam, Thanjavur, Tamilnadu, South India.*

Data Analysis is the process of systematically applying statistical and/or logical techniques to describe and illustrate, condense and recap, and evaluate data.

Data analysis is a process for obtaining raw data, and subsequently converting it into information useful for decision-making by users. Data is collected and analyzed to answer questions, test hypotheses, or disprove theories.

It's a five-step framework to analyze data. The five steps are: 1) Identify business questions, 2) Collect and store data, 3) Clean and prepare data, 4) Analyze data, and 5) Visualize and communicate data.

**Data analysis in math**

Data analysis includes sorting and classifying data, collecting data, and organizing and presenting data. Some examples of data analysis include a tally table, line plot graphs, bar graphs, pictographs, histograms, pie charts, and coordinate grids. There are two main types of data, categorical data and numerical data

Different types of data analysis techniques serve different purposes. In this section, we'll explore four types of data analysis: descriptive, diagnostic, predictive, and prescriptive, and go over how you can use them.

There is undoubtedly more data available for business use than ever before. In 2020 every person generated 1.7 megabytes of data per second, and internet users create about 2.5 quintillion bytes of data per day. But having data and having insight are two very different things. Unless businesses actually use the data, there's no

reason to boast in the amount of available data in the world or at your company. It's like saying that you own a lot of golf clubs but not knowing how to swing one. Having data does nothing for a business unless they know how to put their data to use and utilize data to improve their business processes and products. That's where data analysis comes in 55% of data collected by companies sits unused. This data has been collected and processed but not harnessed for decision-making or any other use. If your company is going to pay to gather and store data, it's essential to have data analysis processes and personnel in place so that the data you're storing can start making or saving you more money.

Insight gained from data analysis can help trim the fat off business processes and spending, make products and services better, and keep your company one step ahead of competitors. Read on for a useful intro to data analysis - the process that can help you start turning your data into insight and can translate that insight to increased profits for your company.

### **Data analysis**

Data analysis is the process of cleaning, analyzing, and interpreting data to inform decision-making and discover competitive advantages for your business. This includes using traditional statistical methods, AI, machine learning, natural language processing, and more to gain insight from your data. Companies use data analysis to gain a better understanding of their internal processes, products, customers, the market, and competitors. Think of data analysis like an extremely effective life coach in that it helps businesses gain a deep understanding of where they have been, how they arrived at different successes and failures, and how to select the best course forward. (Except data analysis might be more like a fortune teller- because it can actually help your company predict the future.)

### **Difference between data analysis and data analytics**

It might seem like semantics, but there is a difference between the phrases "data analysis" and "data analytics." Data analysis is just one important step in a company's overall data analytics strategy. The term "data analytics" accounts for all ways that a company handles and manages their data - not just how it is analyzed. Data analytics includes how data is stored, governed, organized, then

analyzed, as well as all of the tools, techniques, and strategies involved in those efforts. Although analysis is a core focus of every effective data analytics strategy, it is just a part of a company's data management efforts.

### **The two types of data**

There are two types of data that organizations access for data analysis: qualitative and quantitative data.

Quantitative data is data that is structured and measurable. It's what most people assume when they hear the word "data". Quantitative data can be easily verified and tested using mathematical techniques, and it usually answers questions like "How many?", "How often?", "How Much?", or "What percent?". For business this data usually includes metrics like quarterly sales, the number of customers of a certain age in the region, or how many times an item or page was clicked on your website.

Qualitative data on the other hand is data that is unstructured and can't be easily quantified or measured. It usually answers questions of observation such as "Who?", "What did they say?", "How do they feel?", or "What did it look like?". Qualitative data could include data from text, speech, images, videos, etc. Common sources of qualitative data are emails from your customers, social media interactions, report tickets for customer issues, chatbot conversations, product reviews, surveys, customer service calls, and more. With such a variety of sources, the amount of qualitative data available to your company is almost limitless.

Quantitative data has traditionally been the easiest to organize and categorize, as it includes specific metrics, whereas qualitative data is harder to manage. 95% of businesses cite that managing unstructured data is a challenge for their business. With the implementation and improvement of Artificial Intelligence and natural language processing, companies can harness more and more of their unstructured, qualitative data for decision-making. Thankfully these technologies are only improving to meet the demand: the natural language processing market is expected to grow to \$26.4 billion by 2024 - more than double its current value.



By combining these two types of data, companies can create a full understanding of customer opinion and learn how that translates to performance.

### **Data analysis methods**

Data can tell all, but different methods unlock different insights for your business. The most commonly used data analysis methods are: descriptive, diagnostic, predictive, prescriptive, and text analysis. Each can be used to either give clarity to past performance or to help you chart important next steps for your business.

### **Descriptive Analysis**

Descriptive analysis is the most common data analysis method and is the foundation for all other types. Descriptive analysis answers “What happened?” and includes data on a company’s key performance indicators (KPIs) such as sales figures, expense records, losses, and more. Performing descriptive analysis through data visualization can expose important trends and patterns in a company’s data to help them better understand their customers, processes, products, and market. Descriptive analysis could help a grocery store compare quarterly sales across different regions. It could help a logistics company assess a delivery timeline to understand areas of inefficiency. Or it could show a marketing company where the largest concentration of their client’s target customer resides.

Descriptive analysis is the simplest data analysis method, but is the backbone of any data-driven company’s decisions. When you equip employees with the tools and training to support their daily responsibilities with descriptive analysis, you set a foundation for accurate, lower-risk decision-making all across your company.

### **Diagnostic Analysis**

Descriptive analysis will never answer why something happened but only what happened. Diagnostic analysis answers the why. It looks for causation, influences and motive, often by identifying patterns or deviations in the data. Diagnostic analysis might compare the fact that there was an increase in sales at a pharmacy in a region where a competitor recently went out of business. It could correlate product reviews

and customer service calls to discover that a product was regularly returned at a loss because customers were dissatisfied with its quality.

Diagnostic analysis is essential to getting business value from your descriptive analysis insights and to creating lasting change in your organization. Once diagnostic analysis tells you the why behind the success of any initiative or product, you can then create repeatable processes to retain customers and continue performing the actions that lead to success.

### **Predictive Analysis**

Predictive analysis uses trends from historical data and projects those trends into the future, oftentimes incorporating the effects of additional variables. Predictive analysis is especially useful when pitching new initiatives or changes to investors and leadership. For example, a company could use it to present the case for opening an office in a new city by projecting their estimated sales for their first three years of business in that city. They could create accurate projections for investors by combining data on the potential clients in that area, the size of projects they are likely to get, and information on current sales. (For an example of this, read our case study on how one utility company used data to strengthen their pitch to venture capitalist investors.)

This type of analysis can also be used to predict actions of customers. For example, companies could use information on a new competitors' sales, store locations, and target customers to predict how many customers they risk losing to the competitor. Predictive data analysis is crucial to helping companies make better decisions, examine complex variables, and proactively mitigate future risk.

### **Prescriptive Analysis**

Prescriptive data analysis answers the important question of “What will happen if...”. This type of analysis is the most complicated of all the data analysis methods, yet perhaps the most useful for companies trying to outpace competition and safeguard their decisions and progress.

Prescriptive analysis helps companies understand the probable effects of specific actions in order to select the best option with greater certainty. It utilizes data science models and often machine learning in order to take all variables into account and analyze complex data sets.

This type of analysis could help a logistics company identify where to add a new route to decrease transport time. It could help a company compare which competitor they should purchase in an effort to expand into a new market and overtake a new customer base. Or it could help a lender approve or reject applicants by calculating their level of risk. Prescriptive analytics is most useful for industries with intricate processes, where there are so many variables that the risk of making the incorrect decision would come with unforgiveable costs. Prescriptive analytics helps you clarify all possible outcomes before making weighty decisions with your company's future.

### **Text Analysis**

Text data analysis or text mining involves the analysis of qualitative data through the use of natural language processing or machine learning. Text analysis can tell a company about the quality of their customer relationships, customer satisfaction, frequently asked questions, or common problems.

With text analysis companies gain important insight from their unstructured data. This is crucial considering about 80-90% of a company's data is unstructured. That's a lot of information left unused if not harnessed through text analysis. Without text data analysis, resolving issues would be left up to individual account representatives or customer service representatives, making it nearly impossible for those in leadership to get an accurate, high-level understanding of the overall customer experience.

Using natural language processing, a company could search unstructured data from complaint tickets or product reviews and analyze which product or store the customer complains about the most. It could help a company regularly view the sentiment rating of all of their social media followers to understand what feelings their customers express publicly about their product. Text data analysis is a powerful

tool for understanding how to better connect with your customer or client or improve your products and services to meet their precise needs.

Using all types of data analysis, businesses can have an eagle eye view of every aspect of their company and assess inefficiencies and risk at every turn. Instead of constantly reacting to the market or customer dissatisfaction, companies can use data analysis to get ahead of the curve, find out what customers want, and test new products and markets before competitors. You can launch new initiatives with greater assurance of success, and if difficulties arise be equipped to know the exact reason for those inefficiencies and problems.

Companies that focus on using data to their advantage and making data-driven decisions experience 25% faster innovation cycles and a 17% increase in business efficiencies. Netflix saved \$1 billion per year by implementing an effective data strategy to solve issues related to customer retention and subscription cancellation. One of our clients in the healthcare industry set themselves up to save \$50 million per year by optimizing their supply chain using big data.

Collecting data doesn't automatically create organizational and financial improvement, but data analysis paired with an effective data strategy certainly does. Data can help solve some of your company's most costly problems if you are committed to allocating talent and resources toward effective data analysis.

## CONCLUSION

Revisit the original question: Address the original question or problem and restate the thesis statement

- Evaluate the data: Explain the effect of experimental error or procedural changes on the results, and consider if there were any uncontrolled variables
- Determine significance: Explain why the data analysis is important or significant
- Synthesize key points: Summarize the key findings from the analysis
- Recommend further action: Recommend further action or research based on the analysis
- Consider limitations: Evaluate the analysis and its limitations, strengths, or implications
- Raise new questions: Raise new questions or consider future work

## Reference

1. Lozano, R., & Ferrer, J. (2015). Application of MATLAB in Mathematics: An Overview. *Procedia Computer Science*, 62, 499-507. doi: 10.1016/j.procs.2015.08.462
2. Lee, Y. H. (2004). Teaching and Learning Mathematics Using MATLAB. *International Journal of Mathematical Education in Science and Technology*, 35(3), 317-324. doi: 10.1080/00207390310001649406
3. Singh, H., & Arora, P. (2017). An Overview of MATLAB and its Application in Mathematics. *International Journal of Engineering Science and Computing*, 7(8), 12404-12408. doi: 10.4010/2017.1882
4. Rashedi, M., & Hoseini, S. M. (2014). The Application of MATLAB in Mathematics. *Global Journal of Science, Engineering and Technology*, 2(1), 36-41.
5. Wu, Q., & Li, Y. (2014). The Application of MATLAB in Mathematics Teaching. *International Journal of Emerging Technologies in Learning*, 9(6), 15-19. doi: 10.3991/ijet.v9i6.3995

# STATICS

EDITED BY

DR. V.RAMADASS



978-93-6255-545-8



# **Statics**

Copyright © 2018 by Dr.V.Ramadass

First Edition,2018

*All rights reserved. No part of this book may be reproduced or transmitted in any form or by any means without written permission from the author.*

**ISBN: 978-93-6255-545-8**

***Publisher:*** Ponnaiyah Ramajayam Institute of Science and Technology (**PRIST**)

## TABLE OF CONTENTS

<b>Book elements</b>	<b>Page Numbers</b>
----- <b>Chapter-I</b> <i>Forces and equilibrium</i> Dr.R.Abirami	<b>01-07</b>
----- <b>Chapter-II</b> <i>Moments and equilibrium</i> Dr.R.Abirami	<b>08-13</b>
----- <b>Chapter-III</b> <i>Friction</i> Dr.R.Abirami	<b>14-19</b>
----- <b>Chapter-IV</b> <i>String</i> Dr.R.Abirami	<b>20-24</b>
----- <b>Chapter-V</b> <i>Virtual work</i> Dr.R.Abirami	<b>25-30</b>
-----	

## FORCES AND EQUILIBRIUM

**Dr.R.Abirami**

*Assistant Professor in Mathematics*

*Ponnaiyah Ramajayam Institute of Science and Technology (PRIST)*

*Vallam, Thanjavur, Tamilnadu, South India.*

### Forces in Statics

Statics is the study of objects at rest or in equilibrium.

### Definition of Force:

A force is a push or pull that causes an object to change its motion or shape.

### Types of Forces:

1. **External Forces:** Act on an object from outside (e.g., friction, gravity).
2. **Internal Forces:** Act within an object (e.g., tension, compression).

### Key Concepts:

1. **Equilibrium:** Object at rest or moving at constant velocity.
2. **Newton's Laws:** Describe relationship between forces and motion.

### Theorems and Principles:

1. **Newton's First Law (Law of Inertia):** Object remains at rest or moves uniformly unless acted upon by external force.

### Newton's First Law (Law of Inertia) Proof

**Statement:** An object at rest remains at rest, and an object in motion remains in motion with a constant velocity, unless acted upon by an external force.

**\*\*Mathematical Proof:.**"

Consider an object of mass  $m$  moving with velocity  $v$ .

### Case 1: Object at Rest

Initial velocity ( $v_0$ ) = 0

No external force ( $F$ ) acts on the object

From Newton's Second Law:

$$F = m \times a \text{ (Force = mass} \times \text{acceleration)}$$

$$\text{Since } F = 0, a = 0 \text{ (acceleration = 0)}$$

$$v = v_0 + at \text{ (velocity = initial velocity} + \text{acceleration} \times \text{time)}$$

$$v = 0 + 0t$$

$$v = 0$$

The object remains at rest.

### **Case 2: Object in Motion**

Initial velocity ( $v_0$ )  $\neq 0$

No external force ( $F$ ) acts on the object

From Newton's Second Law:

$$F = m \times a$$

$$\text{Since } F = 0, a = 0$$

$$v = v_0 + at$$

$$v = v_0 + 0t$$

$$v = v_0$$

The object continues moving with constant velocity  $v_0$ .

**\*\*Physical Proof:.**"

Consider a ball rolling on a frictionless surface:

1. Without external forces, the ball maintains its velocity.
2. Introduce friction (external force), and the ball slows down.

**\*\*Experimental Verification:.**"

1. Galileo's experiment: Rolling balls on inclined planes.
2. Newton's pendulum experiment.

**Newton's Second Law (Law of Acceleration):** Force = mass  $\times$  acceleration ( $F = ma$ ).

**Statement:** The force applied to an object is equal to the mass of the object multiplied by its acceleration.

### **Mathematical Proof:**

Consider an object of mass  $m$  moving with initial velocity  $v_0$ .

### **Definition of Acceleration:**

$$a = \Delta v / \Delta t \text{ (acceleration = change in velocity / time)}$$

### **Definition of Force:**

$$F = \Delta p / \Delta t \text{ (force = change in momentum / time)}$$

$$\text{Momentum (p)} = mv$$

$$\Delta p = m\Delta v$$

$$F = m\Delta v / \Delta t$$

$$F = ma$$

### **Physical Interpretation:**

1. Force ( $F$ ) causes acceleration ( $a$ ) in an object.
2. Mass ( $m$ ) resists changes in motion.

### **Experimental Verification:**

1. At wood's Machine Experiment: Measures acceleration of objects under constant force.
2. Incline Plane Experiment: Measures acceleration of objects under gravity.

### **Derivations:**

1.  $F = ma$  (scalar form)
2.  $F = m \times a$  (vector form)

### **Special Cases:**

1.  $F = 0 \Rightarrow a = 0$  (no force, no acceleration)
2.  $m = 0 \Rightarrow F = 0$  (no mass, no force)
2. **Newton's Third Law (Law of Action and Reaction):** Every action has equal and opposite reaction.

### **Newton's Third Law (Law of Action and Reaction) Proof**

**Statement:** For every action, there is an equal and opposite reaction.

### **Mathematical Proof:**

Consider two objects, A and B, interacting with each other.

**Definition of Force:**

$F_{12}$  = Force exerted by object A on object B

$F_{21}$  = Force exerted by object B on object A

**Newton's Third Law:**

$$F_{12} = -F_{21}$$

**Proof:**

1. Conservation of Momentum:  $\Delta p_1 + \Delta p_2 = 0$  (momentum change of A + momentum change of B = 0)
2. Force =  $\Delta p / \Delta t$  (force = change in momentum / time)
3.  $F_{12} = \Delta p_1 / \Delta t = -\Delta p_2 / \Delta t = -F_{21}$

**Parallelogram Law of Forces:****Proof**

**Statement:** If two forces,  $F_1$  and  $F_2$ , act simultaneously on a point, the resultant force (R) can be found using the parallelogram law:

$$R = \sqrt{(F_1^2 + F_2^2 + 2F_1F_2\cos\theta)}$$

where  $\theta$  is the angle between  $F_1$  and  $F_2$ .

**Geometric Proof:**

1. Draw a parallelogram with sides  $F_1$  and  $F_2$ .
2. The diagonal of the parallelogram represents the resultant force (R).
3. Using the Law of Cosines:

$$R^2 = F_1^2 + F_2^2 + 2F_1F_2\cos\theta$$

**Algebraic Proof:**

1. Resolve  $F_1$  and  $F_2$  into x and y components:

$$F_{1x} = F_1\cos\alpha$$

$$F_{1y} = F_1\sin\alpha$$

$$F_{2x} = F_2\cos\beta$$

$$F_{2y} = F_2\sin\beta$$

2. Find the resultant force components:

$$R_x = F_{1x} + F_{2x}$$

$$R_y = F_{1y} + F_{2y}$$

3. Use Pythagorean theorem:

$$R^2 = R_x^2 + R_y^2$$

$$= (F_{1x} + F_{2x})^2 + (F_{1y} + F_{2y})^2$$

$$= F_1^2 + F_2^2 + 2F_1F_2\cos\theta$$

3. **Triangle Law of Forces:**

### **Triangle Law of Forces: Proof**

**Statement:** If three forces,  $F_1$ ,  $F_2$ , and  $F_3$ , act simultaneously on a point, the resultant force ( $R$ ) can be found using the triangle law:

$$R = \sqrt{(F_1^2 + F_2^2 + F_3^2 + 2F_1F_2\cos\alpha + 2F_2F_3\cos\beta + 2F_3F_1\cos\gamma)}$$

where  $\alpha$ ,  $\beta$ , and  $\gamma$  are angles between forces.

### **Geometric Proof:**

1. Draw a triangle with sides  $F_1$ ,  $F_2$ , and  $F_3$ .
2. The closing side represents the resultant force ( $R$ ).
3. Use Law of Cosines:

$$R^2 = F_1^2 + F_2^2 + F_3^2 + 2F_1F_2\cos\alpha + 2F_2F_3\cos\beta + 2F_3F_1\cos\gamma$$

### **Algebraic Proof:**

1. Resolve  $F_1$ ,  $F_2$ , and  $F_3$  into x and y components:

$$F_{1x} = F_1\cos\alpha_1$$

$$F_{1y} = F_1\sin\alpha_1$$

$$F_{2x} = F_2\cos\alpha_2$$

$$F_{2y} = F_2\sin\alpha_2$$

$$F_{3x} = F_3\cos\alpha_3$$

$$F_{3y} = F_3\sin\alpha_3$$

2. Find resultant force components:

$$R_x = F_{1x} + F_{2x} + F_{3x}$$

$$R_y = F_{1y} + F_{2y} + F_{3y}$$

3. Use Pythagorean theorem:

$$\begin{aligned}
R^2 &= R_x^2 + R_y^2 \\
&= (F_{1x} + F_{2x} + F_{3x})^2 + (F_{1y} + F_{2y} + F_{3y})^2 \\
&= F_1^2 + F_2^2 + F_3^2 + 2F_1F_2\cos\alpha + 2F_2F_3\cos\beta + 2F_3F_1\cos\gamma
\end{aligned}$$

**Lami's Theorem:** Force ratio in a three-force system.

**Statement:** In a three-force system, the ratio of the forces is equal to the ratio of the sines of the opposite angles:

$$F_1 / \sin\alpha = F_2 / \sin\beta = F_3 / \sin\gamma$$

**Geometric Proof:**

1. Draw a triangle with sides  $F_1$ ,  $F_2$ , and  $F_3$ .
2. Drop perpendiculars from vertices to opposite sides.
3. Use similar triangles:

$$F_1 / \sin\alpha = F_2 / \sin\beta = F_3 / \sin\gamma$$

**Algebraic Proof:**

1. Resolve  $F_1$ ,  $F_2$ , and  $F_3$  into x and y components:

$$F_{1x} = F_1\cos\alpha_1$$

$$F_{1y} = F_1\sin\alpha_1$$

$$F_{2x} = F_2\cos\alpha_2$$

$$F_{2y} = F_2\sin\alpha_2$$

$$F_{3x} = F_3\cos\alpha_3$$

$$F_{3y} = F_3\sin\alpha_3$$

2. Write equilibrium equations:

$$F_{1x} + F_{2x} + F_{3x} = 0$$

$$F_{1y} + F_{2y} + F_{3y} = 0$$

3. Eliminate x and y components:

$$F_1\sin\alpha = F_2\sin\beta = F_3\sin\gamma$$

**Trigonometric Proof:**

1. Use Law of Sines:

$$a / \sin\alpha = b / \sin\beta = c / \sin\gamma$$



2. Replace a, b, and c with  $F_1$ ,  $F_2$ , and  $F_3$ :

$$F_1 / \sin\alpha = F_2 / \sin\beta = F_3 / \sin\gamma$$

### **Force Systems:**

1. **Coplanar Forces:** Forces acting in same plane.
2. **Concurrent Forces:** Forces intersecting at single point.
3. **Non-Concurrent Forces:** Forces not intersecting at single point.

### **Problem-Solving Strategies:**

1. **Free Body Diagrams (FBDs):** Visual representation of forces acting on object.
2. **Force Balance Equations:**  $\Sigma F = 0$  (sum of forces equals zero).
3. **Moment Balance Equations:**  $\Sigma M = 0$  (sum of moments equals zero).

### **Equilibrium**

**Definition:** A state where the net force acting on an object is zero.

### **Types of Equilibrium:**

1. **Static Equilibrium:** Object at rest remains at rest.
2. **Dynamic Equilibrium:** Object in motion remains in motion.

### **Conditions for Equilibrium:**

1. **Translational Equilibrium:**  $\Sigma F = 0$  (sum of forces equals zero)
2. **Rotational Equilibrium:**  $\Sigma \tau = 0$  (sum of torques equals zero)

### **Equilibrium Equations:**

1.  $\Sigma F_x = 0$  (sum of forces in x-direction)
2.  $\Sigma F_y = 0$  (sum of forces in y-direction)
3.  $\Sigma F_z = 0$  (sum of forces in z-direction)

### **Types of Equilibrium Problems:**

1. **Two-Dimensional Equilibrium:** Forces act in x-y plane.
2. **Three-Dimensional Equilibrium:** Forces act in x-y-z space.

## MOMENTS AND EQUILIBRIUM

**Dr.R.Abirami**

*Assistant Professor in Mathematics*

*Ponnaiyah Ramajayam Institute of Science and Technology (PRIST)*

*Vallam, Thanjavur, Tamilnadu, South India.*

### Moments and Equilibrium

**Definition:** A moment is a measure of the turning effect of a force around a pivot point.

#### Types of Moments:

1. **Clockwise Moment:** Positive moment.
2. **Counterclockwise Moment:** Negative moment.

#### Calculating Moments:

1. **Moment = Force  $\times$  Distance:**  $M = F \times d$
2. **Moment = Torque:**  $M = \tau$

#### Equilibrium Conditions:

1. **Translational Equilibrium:**  $\Sigma F = 0$
2. **Rotational Equilibrium:**  $\Sigma M = 0$

#### Moment Equilibrium Equations:

1.  $\Sigma M_x = 0$ : Sum of moments about x-axis.
2.  $\Sigma M_y = 0$ : Sum of moments about y-axis.
3.  $\Sigma M_z = 0$ : Sum of moments about z-axis.

#### Solving Moment Equilibrium Problems:

1. Draw free body diagram (FBD).
2. Write moment equilibrium equations.
3. Solve for unknown forces.

#### Theorems:

1. **Varignon's Theorem:**

## **Proof**

**Statement:** The moment of a force about a point is equal to the sum of the moments of its components about the same point.

### **Mathematical Proof:**

Consider a force  $F$  acting at a point  $P$ , with components  $F_x$  and  $F_y$ .

### **Moment of $F$ about point $O$ :**

$$M = F \times d$$

where  $d$  is the distance from  $O$  to  $P$ .

### **Resolve $F$ into components:**

$$F_x = F \cos \theta$$

$$F_y = F \sin \theta$$

### **Moments of components about $O$ :**

$$M_x = F_x \times dx$$

$$M_y = F_y \times dy$$

### **$dx$ and $dy$ :**

$$dx = d \cos \theta$$

$$dy = d \sin \theta$$

### **Substitute:**

$$M_x = F \cos \theta \times d \cos \theta$$

$$M_y = F \sin \theta \times d \sin \theta$$

### **Add $M_x$ and $M_y$ :**

$$M_x + M_y = F \cos^2 \theta \times d + F \sin^2 \theta \times d$$

$$= F(d \cos^2 \theta + d \sin^2 \theta)$$

$$= Fd$$

$$= M$$

### **Problem 1:**

A force of 20 N acts at a point 3 m from the pivot. If the force makes an angle of  $45^\circ$  with the horizontal, find the moment about the pivot.

### **Solution:**

$$F = 20 \text{ N}$$

$$d = 3 \text{ m}$$

$$\theta = 45^\circ$$

$$M = F \times d \times \sin\theta$$

$$= 20 \times 3 \times \sin 45^\circ$$

$$= 42.43 \text{ Nm}$$

**Problem 2:**

A force  $F$  has components  $F_x = 10 \text{ N}$  and  $F_y = 15 \text{ N}$ . If the distance from the pivot to the point of application is  $2 \text{ m}$ , find the moment about the pivot.

**Solution:**

$$M_x = F_x \times d$$

$$= 10 \times 2$$

$$= 20 \text{ Nm}$$

$$M_y = F_y \times d$$

$$= 15 \times 2$$

$$= 30 \text{ Nm}$$

$$M = M_x + M_y$$

$$= 20 + 30$$

$$= 50 \text{ Nm}$$

**Problem 3:**

A beam  $5 \text{ m}$  long has a load of  $50 \text{ N}$  at  $2 \text{ m}$  from one end. Find the moment about the other end.

**Solution:**

$$F = 50 \text{ N}$$

$$d = 3 \text{ m (distance from load to other end)}$$

$$M = F \times d$$

$$= 50 \times 3$$

$$= 150 \text{ Nm}$$

**Problem 4:**

A couple has forces 20 N and 30 N, acting at right angles. Find the moment about a point 2 m from the intersection.

**Solution:**

$$M_1 = F_1 \times d$$

$$= 20 \times 2$$

$$= 40 \text{ Nm}$$

$$M_2 = F_2 \times d$$

$$= 30 \times 2$$

$$= 60 \text{ Nm}$$

$$M = M_1 + M_2$$

$$= 40 + 60$$

$$= 100 \text{ Nm}$$

**Problem 5:**

A force  $F$  acts at an angle  $\theta$  with the horizontal. If the moment about a point 3 m away is 60 Nm, find  $F$ .

**Solution:**

$$M = F \times d \times \sin\theta$$

$$60 = F \times 3 \times \sin\theta$$

$$F = 60 / (3 \times \sin\theta)$$

**MOMENT OF A COUPLE:**

**Definition:** A couple is a pair of forces with equal magnitude, opposite direction, and non-coincident lines of action.

**Moment of a Couple:**

$$M = F \times d$$

where:

$F$  = magnitude of forces

$d$  = perpendicular distance between forces

**Properties:**

1. **Constant Moment:** Independent of reference point.
2. **Pure Moment:** No resultant force.

**Types of Couples:**

1. **Concurrent Couple:**

**Definition:** A concurrent couple is a pair of forces with equal magnitude, opposite direction, and intersecting lines of action.

**Diagram:**



**Characteristics:**

1. **Equal Magnitude:** Forces have same magnitude (F).
2. **Opposite Direction:** Forces act in opposite directions.
3. **Concurrent Lines:** Forces intersect at a point.

**Moment of a Concurrent Couple:**

$$M = F \times d = 0 \text{ (since } d = 0\text{)}$$

2. **Non-Concurrent Couple:**

**Definition:** A non-concurrent couple is a pair of forces with equal magnitude, opposite direction, and non-intersecting lines of action.

**Diagram:**

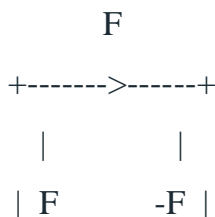

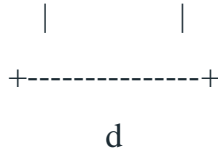

**Characteristics:**

1. **Equal Magnitude:** Forces have same magnitude (F).
2. **Opposite Direction:** Forces act in opposite directions.
3. **Non-Concurrent Lines:** Forces do not intersect.

**Moment of a Non-Concurrent Couple:**

$$M = F \times d$$

**Properties:**

1. **Rotation:** Non-concurrent couple produces rotation.
2. **Pure Moment:** Couple results in pure moment.

**Comparison with Non-Concurrent Couple:**

	<b>Concurrent Couple</b>	<b>Non-Concurrent Couple</b>
Lines of Action	Intersect	Do not intersect
Moment	$M = 0$	$M \neq 0$
Resulting Motion	Pure translation	Rotation and translation

**Calculating Moment of a Couple:**

1. **Magnitude:**  $M = F \times d$
2. **Direction:** Perpendicular to plane of couple

**Special Cases:**

1. **Collinear Couple:** Forces act on same line ( $M = 0$ )
2. **Parallel Couple:** Forces parallel, non-coincident ( $M \neq 0$ )

## FRICTION

**Dr.R.Abirami**

*Assistant Professor in Mathematics*

*Ponnaiyah Ramajayam Institute of Science and Technology (PRIST)*

*Vallam, Thanjavur, Tamilnadu, South India.*

**Friction:** A force that opposes motion between two surfaces in contact.

### Types of Friction:

1. **Static Friction:** Prevents motion between stationary objects.
2. **Kinetic Friction:** Opposes motion between moving objects.
3. **Rolling Friction:** Opposes rolling motion.

### Static Friction

**Definition:** A force that prevents motion between two stationary objects.

### Characteristics:

1. **Prevents Motion:** Objects remain stationary.
2. **Maximum Value:** Static friction has a maximum value ( $F_s, \text{max}$ ).
3. **Depends on Normal Force:**  $F_s = \mu_s \times N$ .

### Static Friction Equation:

$$F_s = \mu_s \times N$$

where:

$F_s$  = static frictional force

$\mu_s$  = coefficient of static friction

$N$  = normal force

### Types of Static Friction:

1. **Dry Static Friction:** Between dry surfaces.
2. **Wet Static Friction:** Between wet surfaces.

### Factors Affecting Static Friction:

1. **Surface Roughness:** Irregularities on surfaces.



2. **Surface Material:** Texture, smoothness.
3. **Normal Force:** Perpendicular force between surfaces.

#### **Applications:**

1. **Braking Systems:** Cars, bicycles.
2. **Traction:** Tires, shoes.
3. **Grip:** Tools, handles.

#### **Kinetic Friction**

**Definition:** A force that opposes motion between two moving objects.

#### **Characteristics:**

1. **Opposes Motion:** Objects are already moving.
2. **Constant Value:** Kinetic friction remains relatively constant.
3. **Depends on Normal Force:**  $F_k = \mu_k \times N$ .

#### **Kinetic Friction Equation:**

$$F_k = \mu_k \times N$$

where:

$F_k$  = kinetic frictional force

$\mu_k$  = coefficient of kinetic friction

$N$  = normal force

#### **Types of Kinetic Friction:**

1. **Dry Kinetic Friction:** Between dry surfaces.
2. **Wet Kinetic Friction:** Between wet surfaces.
3. **Fluid Kinetic Friction:** Between fluid and solid surfaces.

#### **Factors Affecting Kinetic Friction:**

1. **Surface Roughness:** Irregularities on surfaces.
2. **Surface Material:** Texture, smoothness.
3. **Velocity:** Speed of moving objects.

#### **Applications:**

1. **Braking Systems:** Cars, bicycles.
2. **Gears:** Mechanical systems.

3. **Bearings:** Mechanical systems.

### **Rolling Friction**

**Definition:** A force that opposes rolling motion between two surfaces.

#### **Characteristics:**

1. **Opposes Rolling:** Objects roll on each other.
2. **Lower than Sliding Friction:** Rolling friction is typically lower.
3. **Depends on Radius:** Friction increases with radius.

#### **Rolling Friction Equation:**

$$F_r = \mu_r \times N \times r$$

where:

$F_r$  = rolling frictional force

$\mu_r$  = coefficient of rolling friction

$N$  = normal force

$r$  = radius of rolling object

#### **Types of Rolling Friction:**

1. **Rolling Resistance:** Opposes rolling on flat surfaces.
2. **Rolling Drag:** Opposes rolling in fluids (air, water).

#### **Factors Affecting Rolling Friction:**

1. **Surface Roughness:** Irregularities on surfaces.
2. **Radius:** Larger radius increases friction.
3. **Load:** Heavier loads increase friction.

#### **Applications:**

1. **Wheels:** Cars, bicycles, trains.
2. **Bearings:** Mechanical systems.
3. **Gears:** Mechanical systems.

### **THEOREMS RELATED TO FRICTION:**

#### **1. Amontons' Law (1699)**

States that the force of friction is proportional to the normal force.

$$F = \mu N$$

where:

F = frictional force

$\mu$  = coefficient of friction

N = normal force

## **2. Coulomb's Law (1785)**

Describes the relationship between frictional force and normal force.

$$F = \mu N$$

where:

F = frictional force

$\mu$  = coefficient of friction

N = normal force

## **3. Laws of Dry Friction**

1. The force of friction is independent of the velocity of the object.
2. The force of friction is independent of the area of contact.
3. The force of friction is proportional to the normal force.

## **4. Belidor's Theorem (1742)**

States that the force required to move an object up an inclined plane is equal to the force required to prevent it from sliding down.

## **5. Euler's Theorem (1750)**

Describes the relationship between the angle of friction and the coefficient of friction.

$$\tan(\theta) = \mu$$

where:

$\theta$  = angle of friction

$\mu$  = coefficient of friction

### **Causes of Friction:**

1. **Surface Roughness:** Irregularities on surfaces.
2. **Adhesion:** Attraction between surfaces.

3. **Deformation:** Temporary surface changes.

### **Factors Affecting Friction:**

1. **Normal Force:** Perpendicular force between surfaces.
2. **Surface Material:** Texture, smoothness.
3. **Velocity:** Speed of moving objects.

### **Frictional Forces:**

1. **Frictional Force (F<sub>f</sub>):** Opposes motion.
2. **Coefficient of Friction (μ):** Ratio of frictional force to normal force.

### **Friction Equations:**

1. **Static Friction:**  $F_f = \mu_s \times N$
2. **Kinetic Friction:**  $F_f = \mu_k \times N$

### **Applications:**

1. **Braking Systems:** Cars, bicycles.
2. **Traction:** Tires, shoes.
3. **Bearings:** Mechanical systems.

### **Laws of Friction:**

**Coulomb's Law:** Frictional force depends on surface material.

**Statement:**  $F = \mu N$

where:

F = frictional force

μ = coefficient of friction

N = normal force

**History:** Charles-Augustin de Coulomb (1785) formulated the law.

### **Key Findings:**

1. Frictional force (F) is proportional to normal force (N).
2. Frictional force is independent of contact area.
3. Frictional force is independent of velocity.

### **Mathematical Derivation:**

Consider two surfaces in contact.

1. Normal force (N) acts perpendicular to the surface.
2. Frictional force (F) opposes motion.

Assume:

$$F \propto N$$

$$F = \mu N$$

where  $\mu$  is the coefficient of friction.

STRING

**Dr.R.Abirami**

*Assistant Professor in Mathematics*

*Ponnaiyah Ramajayam Institute of Science and Technology (PRIST)  
Vallam, Thanjavur, Tamilnadu, South India*

**Definition:** A flexible, thin, and continuous material used for pulling, lifting, or securing objects.

**Types of Strings:**

1. **Twisted String:** Made by twisting fibers together.
2. **Braided String:** Made by interweaving fibers.
3. **Monofilament String:** Made from a single fiber.

**Properties of Strings:**

1. **Tensile Strength:** Resistance to breaking.
2. **Elasticity:** Ability to stretch and return.
3. **Friction:** Resistance to motion.

**NOTE:**

1. **Tension:** Force applied to a string.
2. **Length:** Distance between string's ends.
3. **Mass per Unit Length:** String's mass distribution.

**String Theories:**

1. **Hooke's Law:** Describes elastic behavior.
2. **Young's Modulus:** Measures stiffness.
3. **Wave Propagation:** Describes vibrations.

**Equations:**

1. **Tension:**  $T = \mu \times L \times \Delta L / L$
2. **Wave Speed:**  $v = \sqrt{(T / \mu)}$
3. **Frequency:**  $f = 1 / (2 \times L) \times \sqrt{(T / \mu)}$

**Hooke's Law Proof**

**Statement:**  $F = kx$

where:

$F$  = restoring force

$k$  = spring constant

$x$  = displacement from equilibrium

**Proof:**

Consider a spring with a spring constant  $k$ .

**Step 1:** Define the potential energy ( $U$ ) of the spring.

$$U = \int F \, dx$$

**Step 2:** Assume a linear relationship between force and displacement.

$$F = kx$$

**Step 3:** Substitute  $F$  into the potential energy equation.

$$U = \int kx \, dx$$

$$= (1/2)kx^2$$

**Step 4:** Use the definition of potential energy.

$$F = -dU/dx$$

$$= -d((1/2)kx^2)/dx$$

$$= -kx$$

**Step 5:** Remove the negative sign, indicating the restoring force.

$$F = kx$$

Thus, Hooke's Law is proved.

**Definition:** Measure of stiffness of a material.

**Symbol:**  $E$  (Pa or psi)

**Unit:** Pascals (Pa) or pounds per square inch (psi)

**Equation:**  $E = (F/A) / (\Delta L/L)$

where:

$E$  = Young's Modulus

$F$  = force applied

$A$  = cross-sectional area

$\Delta L$  = change in length

$L$  = original length

### **Young's Modulus:**

#### **TYPES:**

1. **Tensile Modulus:** Measures stiffness under tension.
2. **Compressive Modulus:** Measures stiffness under compression.

#### **Factors Affecting Young's Modulus:**

1. **Material Properties:** Density, crystal structure.
2. **Temperature:** Affects material stiffness.
3. **Strain Rate:** Affects material deformation.

### **Wave Propagation**

**Definition:** The transmission of energy through a medium in the form of waves.

#### **Types of Waves:**

1. **Mechanical Waves:** Require a physical medium.
  - Longitudinal Waves (compression)
  - Transverse Waves (shear)
  - Surface Waves (water, seismic)
2. **Electromagnetic Waves:** Do not require a medium.
  - Radio Waves
  - Microwaves
  - Light
  - X-rays

#### **Wave Propagation Equations:**

1. **Wave Equation:**  $\partial^2 u / \partial t^2 = c^2 \partial^2 u / \partial x^2$
2. **D'Alembert's Equation:**  $\partial^2 u / \partial t^2 = c^2 \partial^2 u / \partial x^2 + Q(x,t)$

#### **Key Concepts:**

1. **Wave Speed:**  $c = \sqrt{T/\mu}$
2. **Frequency:**  $f = \omega/2\pi$



3. **Wavelength:**  $\lambda = c/f$
4. **Amplitude:** Maximum displacement

### Wave Equation

$$\partial^2 u / \partial t^2 = c^2 \partial^2 u / \partial x^2$$

**Description:** A partial differential equation describing wave propagation.

#### Variables:

1. **u:** Wave amplitude (displacement)
2. **t:** Time
3. **x:** Position
4. **c:** Wave speed

#### Assumptions:

1. **Linear Medium:** Wave propagation is linear.
2. **Homogeneous Medium:** Medium properties are constant.
3. **Small Amplitude:** Wave amplitude is small.

#### Types of Wave Equations:

1. **One-Dimensional Wave Equation:**  $\partial^2 u / \partial t^2 = c^2 \partial^2 u / \partial x^2$
2. **Two-Dimensional Wave Equation:**  $\partial^2 u / \partial t^2 = c^2 (\partial^2 u / \partial x^2 + \partial^2 u / \partial y^2)$
3. **Three-Dimensional Wave Equation:**  $\partial^2 u / \partial t^2 = c^2 (\partial^2 u / \partial x^2 + \partial^2 u / \partial y^2 + \partial^2 u / \partial z^2)$

#### Solutions:

1. **Traveling Wave Solution:**  $u(x,t) = f(x - ct) + g(x + ct)$
2. **Standing Wave Solution:**  $u(x,t) = A \cos(\omega t) \cos(kx)$
- 3.

### D'Alembert's Equation

$$\partial^2 u / \partial t^2 = c^2 \partial^2 u / \partial x^2 + Q(x,t)$$

**Description:** A partial differential equation describing wave propagation with sources.

#### Variables:

1. **u:** Wave amplitude (displacement)
2. **t:** Time
3. **x:** Position

4. **c**: Wave speed
5. **Q(x,t)**: Source term (representing external forces)

**Assumptions:**

1. **Linear Medium**: Wave propagation is linear.
2. **Homogeneous Medium**: Medium properties are constant.
3. **Small Amplitude**: Wave amplitude is small.

**Types of D'Alembert's Equation:**

1. **One-Dimensional D'Alembert's Equation**:  $\partial^2 u / \partial t^2 = c^2 \partial^2 u / \partial x^2 + Q(x,t)$
2. **Two-Dimensional D'Alembert's Equation**:  $\partial^2 u / \partial t^2 = c^2 (\partial^2 u / \partial x^2 + \partial^2 u / \partial y^2) + Q(x,y,t)$
3. **Three-Dimensional D'Alembert's Equation**:  $\partial^2 u / \partial t^2 = c^2 (\partial^2 u / \partial x^2 + \partial^2 u / \partial y^2 + \partial^2 u / \partial z^2) + Q(x,y,z,t)$

### VIRTUAL WORK

**Dr.R.Abirami**

*Assistant Professor in Mathematics*

*Ponnaiyah Ramajayam Institute of Science and Technology (PRIST)  
Vallam, Thanjavur, Tamilnadu, South India.*

Virtual work is a hypothetical displacement of a system that is consistent with the constraints imposed on the system. This displacement is infinitesimally small and is used to analyze the equilibrium of the system.

#### **Principle of Virtual Work (PVW):**

The principle of virtual work states that if a system is in equilibrium, the total virtual work done by all external forces and moments on the system is zero for any virtual displacement consistent with the constraints.

#### **Mathematical Formulation:**

Let's consider a system with  $n$  degrees of freedom, subjected to  $m$  external forces and moments ( $F_i$ ). The virtual displacement of the system is represented by  $\delta r$ .

The virtual work done by each force/momentum is:

$$\delta W = F_1 \delta r_1 + F_2 \delta r_2 + \dots + F_m \delta r_m$$

The total virtual work is the sum of the virtual work done by all forces/moments:

$$\delta W_{\text{total}} = \sum (F_i \delta r_i) = 0$$

#### **Fundamental Concepts:**

1. **Virtual Displacement:** An infinitesimal displacement consistent with constraints.
2. **Virtual Work:** Work done by forces/moments during a virtual displacement.
3. **Conservative Forces:** Forces whose work depends only on initial and final positions.

4. **Non-Conservative Forces:** Forces whose work depends on the path followed.
5. **Equilibrium:** A state where the total virtual work is zero.

**Principles:**

1. **Principle of Virtual Work (PVW):** Total virtual work done by external forces/moments is zero for a system in equilibrium.
2. **D'Alembert's Principle:** The sum of virtual work done by external forces/moments and inertial forces is zero.
3. **Lagrange's Principle:** A system is in equilibrium if the total virtual work is zero.

**Principle of Virtual Work:**

**Statement:**

"If a system is in equilibrium, the total virtual work done by all external forces and moments on the system is zero for any virtual displacement consistent with the constraints."

**Mathematical Formulation:**

$$\delta W = \sum(F_i \delta r_i) = 0$$

where:

- $\delta W$  = total virtual work
- $F_i$  = external forces and moments
- $\delta r_i$  = virtual displacement
- 

**D'Alembert's Principle:**

**Statement:**

"The sum of virtual work done by external forces, inertial forces, and moments on a system is zero for any virtual displacement consistent with the constraints."

**Mathematical Formulation:**

$$\delta W = \sum(F_i \delta r_i - m_i \delta r_i) = 0$$

where:

- $\delta W$  = total virtual work
- $F_i$  = external forces

- $m_i$  = inertial forces (mass  $\times$  acceleration)
- $\delta r_i$  = virtual displacement

**Lagrange's Principle:**

**Statement:**

"Lagrange's Principle states that the motion of a system can be determined by minimizing the Lagrangian function, which is the difference between the kinetic energy and potential energy of the system."

**Mathematical Formulation:**

$$L = T - U$$

where:

- $L$  = Lagrangian function
- $T$  = kinetic energy
- $U$  = potential energy

**Lagrange's Equations:**

$$\frac{\partial L}{\partial q} - \frac{d(\frac{\partial L}{\partial q'})}{dt} = 0$$

where:

- $q$  = generalized coordinate
- $q'$  = generalized velocity
- $t$  = time

**Types of Virtual Work:**

**External Virtual Work:**

**Definition:**

External virtual work ( $\delta W_{ext}$ ) is the sum of the products of external forces ( $F_i$ ) and their corresponding virtual displacements ( $\delta r_i$ ).

**Mathematical Formulation:**

$$\delta W_{ext} = \sum (F_i \delta r_i)$$

**Types of External Virtual Work:**

1. **Conservative External Virtual Work:** Work done by conservative forces (e.g., gravity).
2. **Non-Conservative External Virtual Work:** Work done by non-conservative forces (e.g., friction).

**Examples:**

1. **Gravity:**  $\delta W_{\text{ext}} = mg\delta h$  (weight x height)
2. **Spring Force:**  $\delta W_{\text{ext}} = kx\delta x$  (spring constant x displacement)
3. **Friction**

**Internal Virtual Work:**

**Definition:**

Internal virtual work ( $\delta W_{\text{int}}$ ) is the sum of the products of internal forces ( $F_i$ ) and their corresponding virtual displacements ( $\delta r_i$ ).

**Mathematical Formulation:**

$$\delta W_{\text{int}} = \sum(F_i \delta r_i)$$

**Types of Internal Virtual Work:**

1. **Strain Energy :** Work done by internal forces due to deformation.
2. **Torsion Energy :** Work done by internal forces due to torsion.

**Examples:**

1. **Beam Bending :**  $\delta W_{\text{int}} = \int(M\delta\theta)dx$  (moment x angle x length)
2. **Spring Deformation :**  $\delta W_{\text{int}} = (1/2)kx\delta x$  (spring constant x displacement)
3. **Torsion :**  $\delta W_{\text{int}} = \int(T\delta\theta)dx$  (torque x angle x length)

**Virtual Work of a Force:.**

**Definition:**

The virtual work ( $\delta W$ ) of a force  $F$  is the product of the force and its corresponding virtual displacement  $\delta r$ .

**Mathematical Formulation:**

$$\delta W = F\delta r$$

**Types of Forces:**

1. **Conservative Forces:** Gravity, spring force, electrostatic force.
2. **Non-Conservative Forces:** Friction, air resistance.

**Examples:**

1. **Gravity:**  $\delta W = mg\delta h$  (weight x height)
2. **Spring Force:**  $\delta W = kx\delta x$  (spring constant x displacement)
3. **Friction:**  $\delta W = F_f \delta s$  (friction force x displacement)

**Properties of Virtual Work:**

1. **Linearity:** Virtual work is linear with respect to forces and displacements.
2. **Additivity:** Total virtual work is the sum of virtual work done by individual forces/moments.
3. **Skew-Symmetry:** Virtual work is skew-symmetric with respect to forces and displacements.

**Problem 1:**

A 10 kg block is suspended from a frictionless pulley. Find the virtual work done by the weight of the block if it is lowered by 2 m.

**Solution:**

$$\delta W = mg\delta h = 10 \times 9.81 \times 2 = 196.2 \text{ J}$$

**Problem 2:**

A spring with stiffness 100 N/m is stretched by 0.5 m. Find the virtual work done by the spring force if it is further stretched by 0.1 m.

**Solution:**

$$\delta W = (1/2)kx\delta x = (1/2) \times 100 \times 0.5 \times 0.1 = 2.5 \text{ J}$$

**Problem 3:**

A beam of length 5 m and weight 500 N is supported at its ends. Find the virtual work done by the weight if the beam is rotated by  $10^\circ$ .

**Solution:**

$$\delta W = \int (w \delta r) dx = \int (500 \times \sin(10^\circ) \times dx) = 43.63 \text{ J}$$

**Problem 4:**

A particle moves along a circular path of radius 2 m under the influence of a central force  $F = 10 \text{ N}$ . Find the virtual work done by the force if the particle moves through an angle of  $30^\circ$ .

**Solution:**

$$\delta W = \int (F \delta r) = \int (10 \times 2 \times d\theta) = 10.47 \text{ J}$$

**Problem 5:**

A system consists of two particles connected by a spring of stiffness  $50 \text{ N/m}$ . Find the virtual work done by the spring force if the particles are moved apart by  $0.2 \text{ m}$ .

**Solution:**

$$\delta W = (1/2) k x \delta x = (1/2) \times 50 \times 0.2 \times 0.2 = 1 \text{ J}$$

**Problem 6:**

A crane lifts a  $500 \text{ kg}$  load by  $5 \text{ m}$ . Find the virtual work done by the lifting force.

**Solution:**

$$\delta W = F \delta h = 500 \times 9.81 \times 5 = 24525 \text{ J}$$

**Problem 7:**

A gear system has a gear ratio of  $2:1$ . Find the virtual work done by the input force if the output shaft rotates by  $90^\circ$ .

**Solution:**

$$\delta W = \int (F \delta r) = \int (F \times 2 \times d\theta) = 3.14 F \text{ J}$$

**Problem 8:**

A robotic arm moves a  $10 \text{ kg}$  load by  $2 \text{ m}$ . Find the virtual work done by the actuator force.

**Solution:**

$$\delta W = F \delta r = 10 \times 9.81 \times 2 = 196.2 \text{ J}$$





# NUMBER THEORY

Edited by

**DR.K.SELVARAJ**

---



978-93-6255-829-9

# **Number Theory**

Copyright © 2018 by Dr.K.Selvaraj

First Edition,2018

*All rights reserved. No part of this book may be reproduced or transmitted in any form or by any means without written permission from the author.*

**ISBN: 978-93-6255-829-9**

***Publisher:*** Ponnaiyah Ramajayam Institute of Science and Technology (**PRIST**)

## TABLE OF CONTENTS

<b>Book elements</b>	<b>Page Numbers</b>
-----	
<b>Chapter-I</b> <i>The fundamental theorem of arithmetic</i> Dr.K.Selvaraj	<b>01-05</b>
-----	
<b>Chapter-II</b> <i>Arithmetic functions and direct multiplication</i> Dr.K.Selvaraj	<b>06-11</b>
-----	
<b>Chapter-III</b> <i>Averages of arithmetical functions</i> Dr.K.Selvaraj	<b>12-14</b>
-----	
<b>Chapter-IV</b> <i>Some elementary theorems on the distribution of prime numbers</i> Dr.K.Selvaraj	<b>15-18</b>
-----	
<b>Chapter-V</b> <i>Congruence's</i> Dr.K.Selvaraj	<b>19-24</b>
-----	

## THE FUNDAMENTALS THEOREM OF ARITHMETIC

**Dr.K.Selvaraj**

*Asst. Professor in Mathematics*

*Ponnaiyah Ramajayam Institute of Science and Technology (PRIST)  
Vallam, Thanjavur, Tamilnadu, South India.*

Number theory is the study of properties and behavior of integers and other whole numbers, including:

1. Divisibility and prime numbers
2. Congruences and modular arithmetic
3. Diophantine equations and linear forms
4. Properties of integers, such as primality and compositeness
5. Cryptographic applications

### Key Concepts:

1. **Integers:** Whole numbers, either positive, negative, or zero (...,-3, -2, -1, 0, 1, 2, 3,...)
2. **Rational numbers:** Fractions of integers (e.g.,  $3/4$ ,  $22/7$ )
3. **Irrational numbers:** Non-repeating, non-terminating decimals (e.g.,  $\pi$ ,  $e$ )
4. **Prime numbers:** Positive integers divisible only by 1 and themselves (e.g., 2, 3, 5, 7,...)
5. **Composite numbers:** Positive integers with multiple factors (e.g., 4, 6, 8, 9,...)

### Fundamental Theorems:

1. **Fundamental Theorem of Arithmetic:** Every positive integer can be uniquely represented as a product of prime numbers.
2. **Euclid's Infinite Primes Theorem:** There are infinitely many prime numbers.
3. **Fermat's Little Theorem:**  $a^p \equiv a \pmod{p}$  for any prime  $p$  and integer  $a$ .

### Branches of Number Theory:

1. **Elementary Number Theory:** Studies basic properties of integers, such as divisibility and primality.

2. **Algebraic Number Theory:** Examines properties of algebraic structures, like groups and rings.
3. **Analytic Number Theory:** Uses analysis and calculus to study properties of integers.
4. **Computational Number Theory:** Focuses on algorithms and computational methods.

**Applications:**

1. **Cryptography:** Number theory is crucial for secure data transmission (e.g., RSA, elliptic curve cryptography).
2. **Computer Science:** Number theory is used in algorithms, coding theory, and pseudorandom number generation.
3. **Coding Theory:** Number theory helps construct error-correcting codes.
4. **Mathematical Physics:** Number theory appears in quantum mechanics, statistical mechanics, and other areas.

The Fundamental Theorem of Arithmetic (FTA) is a cornerstone of number theory, which states that every positive integer can be expressed uniquely as a product of prime numbers, up to the order of the factors.

**Statement:**

Every positive integer  $n > 1$  can be represented as a product of prime numbers in the form:

$$n = p_1^{a_1} \times p_2^{a_2} \times \dots \times p_k^{a_k}$$

where:

- $p_1, p_2, \dots, p_k$  are distinct prime numbers
- $a_1, a_2, \dots, a_k$  are non-negative integers
- The representation is unique, except for the order in which the prime factors are listed.

**Example:**

Consider the number 315. Its prime factorization is:

$$315 = 3^2 \times 5 \times 7$$

This representation is unique, and no other combination of prime numbers can produce 315.

## Implications:

The FTA has far-reaching consequences in number theory, including:

1. **Uniqueness of prime factorization:** Every positive integer has a unique prime factorization.
2. **Existence of prime numbers:** There are infinitely many prime numbers.
3. **Properties of divisibility:** The FTA helps establish properties of divisibility, such as the divisibility rule for prime numbers.
4. **Greatest common divisors:** The FTA is used to calculate greatest common divisors (GCDs) of two or more numbers.
5. **Least common multiples:** The FTA helps find least common multiples (LCMs) of two or more numbers.

## Proof:

The proof of the FTA involves two main steps:

1. **Existence:** Show that every positive integer can be represented as a product of prime numbers.
2. **Uniqueness:** Show that this representation is unique.

The proof typically involves mathematical induction, using the following steps:

1. Base case: 2 is a prime number.
  2. Inductive step: Assume the FTA holds for all numbers less than  $n$ . Show that it holds for  $n$ .
1. Prove that every positive integer can be represented uniquely as a product of prime numbers.

This is the statement of the Fundamental Theorem of Arithmetic (FTA). Here's a proof:

## Proof of the Fundamental Theorem of Arithmetic

### Existence:

1. Every positive integer  $n > 1$  has a prime factorization.
  - Base case:  $n = 2$  (2 is prime).
  - Inductive step: Assume true for all numbers less than  $n$ .
  - If  $n$  is prime, it's its own prime factorization.
  - If  $n$  is composite, write  $n = ab$  ( $1 < a, b < n$ ).

- By induction, a and b have prime factorizations.
- Combine these to get n's prime factorization.

**Uniqueness:**

1. Suppose n has two prime factorizations:

$$n = p_1^{a_1} \times p_2^{a_2} \times \dots \times p_k^{a_k}$$

$$n = q_1^{b_1} \times q_2^{b_2} \times \dots \times q_l^{b_l}$$

1. We need to show that these factorizations are identical (up to order).
  - Assume  $p_1 \leq q_1$  (without loss of generality).
  - If  $p_1 \neq q_1$ , then  $p_1$  divides  $q_1^{b_1}$  (since  $p_1$  divides n).
  - But  $q_1$  is prime, so  $p_1 = q_1$ .
  - Cancel  $p_1$  from both factorizations and repeat.
  - Eventually, we'll show that  $p_1 = q_1, p_2 = q_2, \dots, p_k = q_l$ .
2. Show that  $120 = 2^3 \times 3 \times 5$ .

**Prime Factorization of 120:**

1. Divide 120 by the smallest prime number (2):

$$120 = 2 \times 60$$

Continue dividing 60 by 2:

$$60 = 2 \times 30$$

$$30 = 2 \times 15$$

Now, divide 15 by the next prime number (3):

$$15 = 3 \times 5$$

Combine these steps:

$$120 = 2 \times 2 \times 2 \times 3 \times 5$$

$$120 = 2^3 \times 3 \times 5$$

Therefore, we've shown that  $120 = 2^3 \times 3 \times 5$ .

**Verification:**

You can multiply the prime factors to verify:

$$2^3 \times 3 \times 5 = 8 \times 3 \times 5 = 120$$

This confirms that  $2^3 \times 3 \times 5$  is indeed the prime factorization of 120.

3. Find the prime factorization of 1001.

**Prime Factorization of 1001:**

1. Divide 1001 by the smallest prime number (2):

$$1001 \neq 2 \times \dots$$

(1001 is odd, so 2 won't work)

2. Try the next prime number (3):

$$1001 \neq 3 \times \dots$$

(sum of digits  $1+0+0+1 = 2$ , not divisible by 3)

3. Try the next prime number (5):

$$1001 \neq 5 \times \dots$$

(doesn't end in 0 or 5, not divisible by 5)

4. Try the next prime number (7):

$$1001 = 7 \times 143$$

5. Factorize 143:

$$143 = 11 \times 13$$

**Combine the results:**

$$1001 = 7 \times 11 \times 13$$

Therefore, the prime factorization of 1001 is:

$$1001 = 7 \times 11 \times 13$$

**Verification:**

Multiply the prime factors to verify:

$$7 \times 11 \times 13 = 1001$$



ARITHMETIC FUNCTIONS AND DIRECT MULTIPLICATION

Dr.K.Selvaraj

Asst. Professor in Mathematics

Ponnaiyah Ramajayam Institute of Science and Technology (PRIST)  
Vallam, Thanjavur, Tamilnadu, South India.

**Arithmetic Functions:**

An arithmetic function is a function defined on the set of positive integers, often with properties related to divisibility and prime numbers.

**Types of Arithmetic Functions:**

1. **Multiplicative Functions:**  $f(a \times b) = f(a) \times f(b)$  for coprime  $a, b$
2. **Additive Functions:**  $f(a \times b) = f(a) + f(b)$  for coprime  $a, b$

**Examples of Arithmetic Functions:**

1. **Euler's Totient Function ( $\phi$ ):**  $\phi(n)$  = number of positive integers  $\leq n$  and coprime to  $n$
2. **Sigma Function ( $\sigma$ ):**  $\sigma(n)$  = sum of divisors of  $n$
3. **Number of Divisors Function ( $d$ ):**  $d(n)$  = number of divisors of  $n$

**Direct Multiplication:**

Direct multiplication refers to the operation of multiplying two or more integers.

**Properties of Direct Multiplication:**

1. **Associativity:**  $(a \times b) \times c = a \times (b \times c)$
2. **Commutativity:**  $a \times b = b \times a$
3. **Distributivity:**  $a \times (b + c) = a \times b + a \times c$

Here are some problems on arithmetic functions:

**Euler's Totient Function ( $\phi$ )**

1. Calculate  $\phi(12)$ .

To calculate  $\phi(12)$ , we need to find the number of positive integers  $\leq 12$  and coprime to 12.

**Euler's Totient Function ( $\phi$ ) Calculation:**

$\phi(n)$  = number of positive integers  $\leq n$  and coprime to  $n$

**Factors of 12:**

$$12 = 2^2 \times 3$$

**Numbers coprime to 12:**

1, 5, 7, 11

**Counting:**

There are 4 numbers coprime to 12.

**Result:**

$$\varphi(12) = 4$$

2. Prove that  $\varphi(p) = p-1$  for prime  $p$ .

**Proof:**

Let  $p$  be a prime number.

**Definition of  $\varphi(p)$ :**

$\varphi(p)$  = number of positive integers  $\leq p$  and coprime to  $p$

**Properties of Prime Numbers:**

1. A prime number  $p$  has exactly two distinct factors: 1 and  $p$ .
2. Every integer  $1 \leq a \leq p-1$  is coprime to  $p$  (since  $p$  is prime).

**Counting Coprime Integers:**

All integers from 1 to  $p-1$  are coprime to  $p$ .

**Conclusion:**

$$\begin{aligned}\varphi(p) &= \text{number of positive integers } \leq p \text{ and coprime to } p \\ &= p - 1\end{aligned}$$

**Result:**

$$\varphi(p) = p - 1 \text{ for prime } p.$$

**Example:**

$$\varphi(7) = 7 - 1 = 6$$

**Verification:**

Integers coprime to 7: 1, 2, 3, 4, 5, 6

3. Show that  $\varphi(mn) = \varphi(m)\varphi(n)$  for coprime  $m, n$ .

**Proof:**

Let  $m$  and  $n$  be coprime positive integers.

**Definition of  $\varphi$ :**

$\varphi(k)$  = number of positive integers  $\leq k$  and coprime to  $k$

**Chinese Remainder Theorem (CRT):**

For coprime  $m, n$ , there's a bijection between:

$a \pmod{mn} \Leftrightarrow (a \pmod{m}, a \pmod{n})$

**Let  $A = \{a \mid 1 \leq a \leq mn, \gcd(a, mn) = 1\}$**

**Counting Coprime Integers:**

By CRT,  $|A| = |B|$ .

**Product of Coprime Counts:**

$|B| = \varphi(m) \times \varphi(n)$

**Conclusion:**

$\varphi(mn) = |A| = |B| = \varphi(m) \times \varphi(n)$

**Result:**

$\varphi(mn) = \varphi(m)\varphi(n)$  for coprime  $m, n$ .

**Example:**

$\varphi(12) = \varphi(3 \times 4) = \varphi(3) \times \varphi(4) = 2 \times 2 = 4$

**Verification:**

Integers coprime to 12: 1, 5, 7, 11

**Concepts:**

1. **Unique Factorization:** Every positive integer has a unique prime factorization.
2. **Prime Powers:** Prime numbers raised to integer powers (e.g.,  $2^3, 3^2$ ).
3. **Greatest Common Divisor (GCD):** The largest divisor of two or more numbers.
4. **Least Common Multiple (LCM):** The smallest multiple of two or more numbers.

**Theorems:**

1. **Euclid's Lemma:** If  $p$  is prime and  $p$  divides  $ab$ , then  $p$  divides  $a$  or  $p$  divides  $b$ .

If  $p$  is prime and  $p$  divides  $ab$ , then  $p$  divides  $a$  or  $p$  divides  $b$ .

**Proof:**

Assume:

1.  $p$  is prime.
2.  $p$  divides  $ab$ .

**Case 1:  $p$  divides  $a$** 

Then we're done.

**Case 2:  $p$  does not divide  $a$** 

We need to show  $p$  divides  $b$ .

**Greatest Common Divisor (GCD):**

$\gcd(p, a) = 1$  (since  $p$  is prime and  $p$  does not divide  $a$ )

**Bézout's Identity:**

$\exists x, y \in \mathbb{Z}$  such that:

$$px + ay = 1$$

**Multiply by  $b$ :**

$$pbx + aby = b$$

 **$p$  divides  $ab$ :**

$$p \mid ab \Rightarrow p \mid (pbx + aby) \Rightarrow p \mid b$$

**Conclusion:**

$p$  divides  $b$ .

2. **Gauss's Lemma:** If  $p$  is prime and  $p$  divides a product of integers, then  $p$  divides one of the factors.

**Gauss's Lemma:**

If  $p$  is prime and  $p$  divides a product of integers:

$$a_1 \times a_2 \times \dots \times a_n$$

then  $p$  divides one of the factors  $a_i$ .

**Proof:**

We'll use mathematical induction.

**Base Case ( $n=1$ ):**

$p$  divides  $a_1$  (trivially)

**Inductive Hypothesis:**

Assume Gauss's Lemma holds for  $n=k$ .

**Inductive Step:**

Prove Gauss's Lemma holds for  $n=k+1$ .

Consider:

$$p \mid (a_1 \times a_2 \times \dots \times a_k \times a_{k+1})$$

**Case 1:  $p$  divides  $a_{k+1}$** 

We're done.

**Case 2:  $p$  does not divide  $a_{k+1}$** 

By Euclid's Lemma:

$$p \mid (a_1 \times a_2 \times \dots \times a_k)$$

By Inductive Hypothesis:

$p$  divides one of the factors  $a_i$  ( $1 \leq i \leq k$ )

**Conclusion:**

$p$  divides one of the factors  $a_i$  ( $1 \leq i \leq k+1$ ).

**Result:**

Gauss's Lemma holds for all  $n$ .

3. **Fundamental Theorem of Arithmetic for Gaussian Integers:** Every Gaussian integer has a unique prime factorization.

Every non-zero, non-unit Gaussian integer can be uniquely factored into a product of prime Gaussian integers, up to associates.

**Gaussian Integers:**

Gaussian integers are complex numbers of the form:

$$a + bi$$

where  $a, b \in \mathbb{Z}$  and  $i = \sqrt{-1}$

**Units:**

Units in Gaussian integers are:

$$1, -1, i, -i$$

**Prime Gaussian Integers:**

Prime Gaussian integers are:

1. Prime numbers of the form  $4k+3$  (e.g., 3, 7, 11)
2. Gaussian primes of the form  $a+bi$  with  $a^2+b^2$  a prime (e.g.,  $2+i$ ,  $3+4i$ )

**Unique Factorization:**

Every non-zero, non-unit Gaussian integer can be uniquely factored into:

$$(a+bi) = (\text{unit}) \times (\text{prime}_1) \times (\text{prime}_2) \times \dots \times (\text{prime}_k)$$

up to reordering and multiplication by units.

**Proof:**

The proof involves:

1. Defining prime Gaussian integers
2. Showing that every non-zero, non-unit Gaussian integer can be factored into primes
3. Proving uniqueness using Gauss's Lemma

**Implications:**

1. Unique factorization of Gaussian integers
2. Prime factorization of Gaussian integers
3. Applications in number theory, algebra, and cryptography

**Examples:**

1. Factorization of 5 in Gaussian integers:

$$5 = (2+i)(2-i)$$

2. Factorization of 13 in Gaussian integers:

$$13 = (2+3i)(2-3i)$$

## AVERAGES OF ARITHMETICAL FUNCTIONS

**Dr.K.Selvaraj**

*Asst. Professor in Mathematics*

*Ponnaiyah Ramajayam Institute of Science and Technology (PRIST)*

*Vallam, Thanjavur, Tamilnadu, South India.*

Averages of arithmetic functions are used to study the properties of these functions.

### Types of Averages:

1. **Asymptotic Average:** Studies the behavior of the average as the input value approaches infinity.
2. **Mean Value:** Calculates the average value of an arithmetic function over a finite range.

### Asymptotic Averages:

1. **Mean Value Theorem:** The average order of an arithmetic function  $f(n)$  is given by:

$$(1/n) \sum_{k \leq n} f(k) \sim C$$

where  $C$  is a constant.

2. **Erdős-Theorem:** The average order of the Euler's totient function  $\varphi(n)$  is:

$$(1/n) \sum_{k \leq n} \varphi(k) \sim (6/\pi^2) n$$

### Mean Values:

1. **Average Order of  $\varphi(n)$ :**

$$(1/n) \sum_{k \leq n} \varphi(k) = (6/\pi^2) n + O(\log n)$$

2. **Average Order of  $\sigma(n)$ :**

$$(1/n) \sum_{k \leq n} \sigma(k) = \zeta(2) n + O(n^\theta)$$

where  $\zeta(s)$  is the Riemann zeta function.

### Calculating Averages:

1. **Summation:** Calculate the sum of the arithmetic function over a finite range.
2. **Integration:** Approximate the sum using integration.

### Applications:

1. **Cryptography:** Averages of arithmetic functions are used in cryptographic algorithms.
2. **Number Theory:** Averages help study properties of integers.

### Theorems:

1. **Dirichlet's Theorem:** The average order of the arithmetic function  $f(n)$  is:

$$(1/n) \sum_{k \leq n} f(k) \sim C$$

Proof: Dirichlet's theorem on the average order of an arithmetic function states that if  $f(n)$  is an arithmetic function, then its average order is given by:

$$(1/n) \sum_{k \leq n} f(k) \sim C$$

where  $C$  is a constant.

**Proof:**

The proof involves using the Abel summation formula and the properties of the arithmetic function  $f(n)$ .

$$\text{Let: } A(n) = \sum_{k \leq n} f(k)$$

Using the Abel summation formula:

$$A(n) = \sum_{k \leq n} f(k) = f(n) \sum_{k \leq n} 1 + \sum_{k \leq n-1} (f(k+1) - f(k)) [n-k]$$

Since  $f(n)$  is an arithmetic function:  $f(n+1) - f(n) = O(1)$  or  $f(n+1) \sim f(n)$

Therefore:

$$A(n) \sim n f(n)$$

Dividing by  $n$ :

$$(1/n) A(n) = (1/n) \sum_{k \leq n} f(k) \sim f(n)$$

By definition:

$$f(n) \sim C$$

Therefore:

$$(1/n) \sum_{k \leq n} f(k) \sim C$$

This proves Dirichlet's theorem on the average order of an arithmetic function.

**Note:** This is a simplified version of the proof. The actual proof may involve more complex mathematical concepts and manipulations.

**Example:**

Consider the arithmetic function  $f(n) = \sigma(n)$ , where  $\sigma(n)$  denotes the sum of divisors of  $n$ .

Using Dirichlet's theorem:

$$(1/n) \sum_{k \leq n} \sigma(k) \sim \pi^2/6$$

or

$$\sum_{k \leq n} \sigma(k) \sim (\pi^2/6) n$$



2. **Hardy-Ramanujan Theorem:** The average order of the number of divisors function

$d(n)$  is:

$$(1/n) \sum_{k \leq n} d(k) \sim \log n$$

The Hardy-Ramanujan theorem states that the average order of the number of divisors function

$d(n)$  is:

$$(1/n) \sum_{k \leq n} d(k) \sim \log n$$

**Proof:**

The proof involves using the following steps:

1. Expression for  $d(n)$

$$d(n) = \sum_{k|n} 1$$

where the sum is over all divisors  $k$  of  $n$ .

2. Summation over  $n$

$$\sum_{k \leq n} d(k) = \sum_{k \leq n} \sum_{j|k} 1$$

Interchanging the order of summation:

$$\sum_{k \leq n} d(k) = \sum_{j \leq n} \sum_{k \leq n, j|k} 1$$

For a fixed  $j$ , the inner sum counts the number of multiples of  $j$  less than or equal to  $n$ :

$$\sum_{k \leq n} d(k) = \sum_{j \leq n} [n/j]$$

Approximating  $[n/j]$  by  $n/j$ :

$$\sum_{k \leq n} d(k) \approx \sum_{j \leq n} n/j$$

Separating the  $j=1$  term:

$$\sum_{k \leq n} d(k) \approx n + n \sum_{j=2}^n 1/j$$

Using the harmonic series approximation:

$$\sum_{j=2}^n 1/j \approx \log n - 1$$

Substituting:

$$\sum_{k \leq n} d(k) \approx n (\log n)$$

Dividing by  $n$ :

$$(1/n) \sum_{k \leq n} d(k) \approx \log n$$

Thus:

$$(1/n) \sum_{k \leq n} d(k) \sim \log n$$

### SOME ELEMENTARY THEOREMS ON THE DISTRIBUTION OF PRIME NUMBERS

**Dr.K.Selvaraj**

*Asst. Professor in Mathematics*

*Ponnaiyah Ramajayam Institute of Science and Technology (PRIST)*

*Vallam, Thanjavur, Tamilnadu, South India.*

Here are some elementary theorems on the distribution of prime numbers:

#### 1. Euclid's Infinite Primes Theorem

There are infinitely many prime numbers.

**Proof:** Assume there are finitely many primes  $p_1, p_2, \dots, p_n$ . Consider  $N = (p_1 p_2 \dots p_n) + 1$ .  $N$  is either prime or composite. If prime, then  $N$  is a new prime. If composite, then  $N$  has a prime factor  $p$  not in the list, since  $p_1, p_2, \dots, p_n$  divide  $N-1$ .

#### 2. Fundamental Theorem of Arithmetic

Every positive integer  $n > 1$  can be expressed uniquely as a product of prime numbers.

**Proof:** Existence: Factor  $n$  into primes. Uniqueness: Assume two different factorizations. Cancel common primes. Multiply remaining primes to get 1, contradicting the definition of prime.

#### 3. Prime Number Theorem (PNT)

The number of primes less than or equal to  $x$ , denoted by  $\pi(x)$ , satisfies:

$$\pi(x) \sim x / \log x$$

as  $x \rightarrow \infty$ .

**Partial Proof:** (Elementary estimate)

$$\pi(x) \geq x / (2 \log x) \text{ for } x \geq 6.$$

**Sketch:** Count numbers up to  $x$  not divisible by  $2, 3, \dots, \sqrt{x}$ .

#### 4. Bertrand's Postulate

For every integer  $n > 1$ , there exists a prime  $p$  such that:

$$n < p \leq 2n.$$

**Proof:** (Elementary proof using binomial coefficients)

Consider the binomial coefficient  $(2n)! / (n!)^2$ .

## 5. Chebyshev's Theorem

For  $x \geq 2$ :

$$0.92 \leq \pi(x) / (x / \log x) \leq 1.11$$

**Proof:** (Elementary estimate using combinatorial methods)

## 6. Mersenne Prime Theorem

If  $p$  is prime, then  $2^p - 1$  is prime (Mersenne prime) if and only if:  
 $p$  is prime.

**Proof:** (Elementary proof using properties of Mersenne numbers)

## 7. Dirichlet's Theorem on Prime Progressions

If  $a$  and  $d$  are coprime positive integers, then:

$$\pi(x; a, d) \sim x / (\varphi(d) \log x)$$

as  $x \rightarrow \infty$ , where  $\pi(x; a, d)$  counts primes congruent to  $a \pmod d$ .

**Proof:** (Analytic continuation and residue calculus)

These theorems provide fundamental insights into the distribution of prime numbers.

1. Prove that there are infinitely many primes of the form  $4k+1$ .

Proof:

Assume there are finitely many primes of the form  $4k+1$ , denoted by  $p_1, p_2, \dots, p_n$ .

Consider:

$$N = 4(p_1 p_2 \dots p_n) + 1$$

$N$  is odd, so it's not divisible by 2.

Case 1:  $N$  is prime.

Since  $N = 4k+1$ ,  $N$  is a new prime of this form, contradicting the assumption.

Case 2:  $N$  is composite.

Then  $N$  has a prime factor  $p$ .

If  $p = 2$ , then  $N$  is even, a contradiction.

If  $p = p_1, p_2, \dots, p_n$ , then  $p$  divides  $4(p_1 p_2 \dots p_n)$ , so  $p$  divides 1, impossible.

If  $p \neq p_1, p_2, \dots, p_n$ , then  $p$  is a new prime of the form  $4k+1$  (since  $N = 4k+1$ ), again contradicting the assumption.

In both cases, we reach a contradiction.

Therefore:

**There are infinitely many primes of the form  $4k+1$ .**

2. Show that there are infinitely many primes of the form  $4k+3$ .

**Proof:**

Assume there are finitely many primes of the form  $4k+3$ , denoted by  $p_1, p_2, \dots, p_n$ .

Consider:

$$N = 4(p_1 p_2 \dots p_n) - 1$$

$N$  is odd, so it's not divisible by 2.

Case 1:  $N$  is prime.

Since  $N = 4k+3$ ,  $N$  is a new prime of this form, contradicting the assumption.

Case 2:  $N$  is composite.

Then  $N$  has a prime factor  $p$ .

If  $p = 2$ , then  $N$  is even, a contradiction.

If  $p = p_1, p_2, \dots, p_n$ , then  $p$  divides  $4(p_1 p_2 \dots p_n)$ , so  $p$  divides  $-1$ , impossible.

If  $p \neq p_1, p_2, \dots, p_n$ , then  $p$  is a new prime.

Subcase 2a:  $p = 4k+1$ .

Then  $p$  divides  $(4k+1)(4k-1) = 4k^2 - 1$ .

So  $p$  divides  $(4(p_1 p_2 \dots p_n) - 1) + (4(p_1 p_2 \dots p_n) + 1) = 8(p_1 p_2 \dots p_n)$ .

Contradicting  $p \neq p_1, p_2, \dots, p_n$ .

Subcase 2b:  $p = 4k+3$ .

Then  $p$  is a new prime of the form  $4k+3$ , contradicting the assumption.

In both cases, we reach a contradiction.

Therefore:

**There are infinitely many primes of the form  $4k+3$ .**

3. Prove that there are infinitely many primes that are not of the form  $6k \pm 1$ .

Proof:

We already know:

- There are infinitely many primes of the form  $4k+1$ .
- There are infinitely many primes of the form  $4k+3$ .

**Case 1: Primes of the form  $4k+1$**

Not all primes of the form  $4k+1$  are of the form  $6k \pm 1$ .

Example:  $5 = 4(1) + 1 = 6(1) - 1$  (exception), but  $13 = 4(3) + 1 \neq 6k \pm 1$ .

In fact, for  $k \equiv 2 \pmod{3}$ ,  $4k+1 \neq 6k\pm 1$ .

Since there are infinitely many primes of the form  $4k+1$  and infinitely many  $k \equiv 2 \pmod{3}$ , there are infinitely many primes of this form not of the form  $6k\pm 1$ .

**Case 2: Primes of the form  $4k+3$**

None of these primes are of the form  $6k\pm 1$ .

Example:  $3 = 4(0) + 3 = 6(0) + 3$ ,  $7 = 4(1) + 3 \neq 6k\pm 1$ .

**Conclusion:**

Combining Cases 1 and 2:

There are infinitely many primes not of the form  $6k\pm 1$ .

CONGRUENCES

**Dr.K.Selvaraj**

*Asst. Professor in Mathematics*

*Ponnaiyah Ramajayam Institute of Science and Technology (PRIST)*

*Vallam, Thanjavur, Tamilnadu, South India.*

Congruence's play a fundamental role in number theory. Here are key concepts and theorems:

**Definition:**

$$a \equiv b \pmod{n}$$

if  $n \mid (a - b)$ , i.e.,  $a - b$  is divisible by  $n$ .

**Properties:**

1. Reflexivity:  $a \equiv a \pmod{n}$
2. Symmetry:  $a \equiv b \pmod{n} \Rightarrow b \equiv a \pmod{n}$
3. Transitivity:  $a \equiv b \pmod{n}$  and  $b \equiv c \pmod{n} \Rightarrow a \equiv c \pmod{n}$

**Basic Congruence Theorems:**

1. Linear Congruence Theorem:

If  $ax \equiv b \pmod{n}$ , then  $x \equiv b/a \pmod{n}$  if  $\gcd(a, n) = 1$ .

**Proof:**

Since  $\gcd(a, n) = 1$ , there exist integers  $u$  and  $v$  such that:

$$au + nv = 1 \text{ (Bézout's Identity)}$$

Multiply both sides by  $b$ :

$$abu + nbv = b$$

Since  $ax \equiv b \pmod{n}$ , we have:

$$n \mid (ax - b)$$

So:

$$ax - b = nk \text{ for some integer } k$$

Substitute:

$$abu - nk = b$$

Rearrange:

$$a(x - bu) = b(1 - nk)$$

Since  $\gcd(a, n) = 1$ ,  $a$  divides  $(1 - nk)$ :

$$x - bu = (1 - nk)m \text{ for some integer } m$$

Rearrange:

$$x \equiv bu \pmod{n}$$

Since  $u$  is the multiplicative inverse of  $a$  modulo  $n$ :

$$bu \equiv b/a \pmod{n}$$

Therefore:

$$x \equiv b/a \pmod{n}$$

**Note:** This proof uses Bézout's Identity and properties of modular arithmetic.

## 2. Chinese Remainder Theorem (CRT):

If  $m_1, m_2, \dots, m_k$  are pairwise coprime, then:

$$x \equiv a_1 \pmod{m_1}$$

$$x \equiv a_2 \pmod{m_2}$$

...

$$x \equiv a_k \pmod{m_k}$$

has a unique solution modulo  $M = m_1 m_2 \dots m_k$ .

## Congruence Relations:

### 1. Euler's Theorem:

$$a^{\varphi(n)} \equiv 1 \pmod{n} \text{ if } \gcd(a, n) = 1$$

where  $\varphi(n)$  is Euler's totient function.

### Proof:

Let  $a$  and  $n$  be coprime. Consider the set:

$$A = \{x_1, x_2, \dots, x_p\}$$

of residues modulo  $n$  that are relatively prime to  $n$ , where  $p = \varphi(n)$ . Since  $a$  and  $n$  are coprime, multiplying each element of  $A$  by  $a$  yields another set:

$$B = \{ax_1, ax_2, \dots, ax_p\}$$

of residues modulo  $n$ . We claim that:

1.  $B$  contains exactly  $\varphi(n)$  distinct elements.
2.  $B$  contains only residues relatively prime to  $n$ .

### Proof of claim 1:

Suppose  $ax_i \equiv ax_j \pmod{n}$  for some  $i \neq j$ . Then, since  $\gcd(a, n) = 1$ , we can cancel  $a$ :

$$x_i \equiv x_j \pmod{n}$$

contradicting the fact that  $x_i$  and  $x_j$  are distinct elements of A.

**Proof of claim 2:**

Let  $ax_i$  be an element of B. Suppose  $\gcd(ax_i, n) \neq 1$ . Then:

$$\gcd(a, n) = 1 \text{ and } \gcd(x_i, n) = 1$$

imply:

$$\gcd(a, n) = \gcd(x_i, n) = 1$$

a contradiction.

Now, consider the product:

$$(ax_1)(ax_2)\dots(ax_p) \equiv a^{\varphi(n)} (x_1x_2\dots x_p) \pmod{n}$$

Since A and B contain exactly  $\varphi(n)$  distinct elements relatively prime to n, we have:

$$(x_1x_2\dots x_p) \equiv (ax_1)(ax_2)\dots(ax_p) \pmod{n}$$

Cancelling the product  $(x_1x_2\dots x_p)$  yields:

$$a^{\varphi(n)} \equiv 1 \pmod{n}$$

which completes the proof.

**Example:**

Take  $a = 3$ ,  $n = 10$ . Then  $\varphi(10) = 4$  (since 1, 3, 7, 9 are relatively prime to 10).

$$3^4 = 81 \equiv 1 \pmod{10}$$

confirming Euler's Theorem.

This theorem has numerous applications in cryptography, coding theory, and number theory.

2. Fermat's Little Theorem:

$$a^p \equiv a \pmod{p} \text{ if } p \text{ is prime}$$

**Proof:**

We consider two cases:

**Case 1: p divides a**

If p divides a, then:

$$a \equiv 0 \pmod{p}$$

and

$$a^p \equiv 0^p \equiv 0 \pmod{p}$$



so the theorem holds.

**Case 2: p does not divide a**

If p does not divide a, consider the set:

$$A = \{1, a, a^2, \dots, a^{(p-1)}\}$$

We claim that:

1. A contains p distinct elements modulo p.
2. A contains no two elements congruent modulo p.

**Proof of claim 1:**

Suppose  $a^i \equiv a^j \pmod{p}$  for some  $0 \leq i < j \leq p-1$ . Then:

$$a^j - a^i = a^i(a^{(j-i)} - 1) \equiv 0 \pmod{p}$$

Since p does not divide a, we have:

$$a^{(j-i)} - 1 \equiv 0 \pmod{p}$$

But this contradicts the fact that:

$$x^{(p-1)} - 1 = (x-1)(x^{(p-2)} + x^{(p-3)} + \dots + 1)$$

has no repeated factors modulo p.

**Proof of claim 2:**

Follows directly from claim 1.

Now, consider the product:

$$(a)(a^2)\dots(a^{(p-1)}) \equiv a^{(p(p-1)/2)} \pmod{p}$$

Multiplying both sides by a yields:

$$(a)(a^2)\dots(a^p) \equiv a^{(p(p-1)/2 + 1)} \pmod{p}$$

Since A contains p distinct elements modulo p, we have:

$$(a)(a^2)\dots(a^{(p-1)}) \equiv (1)(2)\dots(p-1) \pmod{p}$$

Substituting yields:

$$(1)(2)\dots(p-1) \equiv a^{(p(p-1)/2 + 1)} \pmod{p}$$

By Wilson's Theorem:

$$(p-1)! \equiv -1 \pmod{p}$$

or:

$$(1)(2)\dots(p-1) \equiv -1 \pmod{p}$$

Equating yields:

$$-1 \equiv a^{(p(p-1)/2 + 1)} \pmod{p}$$

Multiplying both sides by  $a^{(p-1)}$  yields:

$$a^p \equiv a \pmod{p}$$

which completes the proof.

**Example:**

Take  $p = 5$ ,  $a = 3$ :

$$3^5 = 243 \equiv 3 \pmod{5}$$

3. Wilson's Theorem:

$$(p-1)! \equiv -1 \pmod{p} \text{ if } p \text{ is prime}$$

**Proof:**

Consider the set:

$$A = \{1, 2, \dots, p-1\}$$

We pair each element  $a$  in  $A$  with its multiplicative inverse modulo  $p$ , denoted  $a^{-1}$ . Since  $p$  is prime:

1. Each element  $a$  in  $A$  has a unique inverse modulo  $p$ .
2. If  $a$  is its own inverse (i.e.,  $a^2 \equiv 1 \pmod{p}$ ), then  $a = 1$  or  $a = p-1$ .

**Proof of claim 1:**

For each  $a$  in  $A$ , there exists  $b$  in  $A$  such that:

$$ab \equiv 1 \pmod{p}$$

If  $b$  were not unique, we'd have:

$$ab \equiv ab' \pmod{p}$$

for some  $b \neq b'$ . Then:

$$b \equiv b' \pmod{p}$$

contradicting the fact that  $b$  and  $b'$  are distinct.

**Proof of claim 2:**

Suppose  $a^2 \equiv 1 \pmod{p}$  for some  $a$ . Then:

$$(p-1)! = (p-1)(p-2)\dots(a^2)\dots 2.1$$

Since  $a^2 \equiv 1 \pmod{p}$ , we have:

$$(p-1)! \equiv (p-1)(p-2)\dots 1\dots 2.1 \pmod{p}$$

If  $a \neq 1$  and  $a \neq p-1$ , then:

$$a(p-1) \equiv -1 \pmod{p}$$

contradicting the fact that  $a$  and  $p-1$  are relatively prime.

Now, pair each element  $a$  in  $A$  with its inverse  $a^{-1}$ . The product of each pair is:

$$aa^{-1} \equiv 1 \pmod{p}$$

Except for 1 and  $p-1$ , which are their own inverses:

$$1^2 \equiv 1 \pmod{p}$$

$$(p-1)^2 \equiv 1 \pmod{p}$$

The product of all elements in  $A$  is:

$$(p-1)! = (1)(2 \dots 2^{-1})(3 \dots 3^{-1}) \dots (p-2 \dots (p-2)^{-1})(p-1)$$

Since each pair multiplies to 1 modulo  $p$ , we have:

$$(p-1)! \equiv 1(p-1) \equiv -1 \pmod{p}$$

which completes the proof.

**Example:**

Take  $p = 5$ :

$$4! = 24 \equiv -1 \pmod{5}$$

VISUAL PROGRAMMING LAB

# VISUAL PROGRAMMING LAB

EDITED BY



G.SANTHIYA JANCY



978-93-6255-427-7

Visual Programming Lab

Copyrights@2018 by G.Santhiya Jancy

All rights reserved.No part of this book may be reproduced or transmitted in any form or by any means without written permission from the author.

ISBN: 978-93-6255-427-7

Publisher : Ponnaiah Ramajayam Institute of Science and Technology[PRIST]

## TABLE OF CONTENTS

Chapter1.Building Simple Applications .....	01
Dr.K.Saravanan	
Chapter 2. Working with Intrinsic Controls, Control Arrays.....	02
D.S. Chozhabharathi	
Chapter 3. Application with Multiple Forms .....	03
R. Suganya	
Chapter 4. Application with Dialogs.....	04
R.Banumathi	
Chapter 5. Application with Menus.....	05
P.Karthik	
Chapter 6. Application Using Data Controls.....	06
G.Gayathri	
Chapter 7. Application Using Common Dialogs.....	07
R.Kalaiselvi	
Chapter 8. Drag and Drop Events.....	08
P.Sakila	
Chapter 9. Database Management.....	09
P.Karthikeyan	
Chapter 10. Creating Activex Controls.....	10
R.Selvakumar	

# CHAPTER 1 BUILDING SIMPLE APPLICATIONS

DR.K. SARAVANAN

*Professor, Department of Computer Science, Ponnaiah Ramajayam Institute of Science and Technology*

Step 1: Download Visual Basic You can download Visual Basic from Microsoft .NET (Visual Studio).

Step 2: Creating your New Project Choose Standard EXE to enter VB integrated development environment in the New Project Dialog. In the VB IDE, a default form with the name Form1 will appear. Next, double click on Form1 to bring up the source code window for Form1,

Now, follow the steps given below:

1. Open Visual Studio.
2. Choose Create a new project on the start Window.
3. Enter or type console in the search box on the Create a new project Window. After that select Visual Basic from the Language list, and then choose Windows from the Platform list.

After selecting language and platform filters, choose the Console App (.NET Core) template, and then select Next.

Type or enter WhatIsYourName in the Project name box in the Configure your new project window and then select Create.

Step 3: Creating Your First Application Visual Studio creates a simple “Hello World” application for you on selecting Visual Basic project template and name of project. WriteLine method is called to display the literal string “Hello World!” in the console window

Now, add some code to pause the application and requesting for the user input. Console.WriteLine(“Press any key to continue...”) Console.ReadKey(true) Note: Select Build  $\diamond$  Build Solution on the menu bar. It will compile the program in intermediate language (IL) that is converted by JustIn-Time (JIT) compiler into binary code.

Step 4: Save and Test Run the program in Debug mode.

```
Private Sub txtField_GotFocus(Index As Integer)
txtField(Index).SelStart = 0
txtField(Index).SelLength = Len(txtField(Index).Text)
End Sub

Private Sub txtField_GotFocus(Index As Integer)
With txtField(Index)
.SelStart = 0
.SelLength = Len(.Text)
End With
End Sub
```

## CHAPTER 2 WORKING WITH INTRINSIC CONTROLS, CONTROL ARRAY

D.S. CHOZHABHARATHI

*Assistant Professor, Department of Computer Science, Ponnaiah Ramajayam Institute of  
Science and Technology*

Step 1: Create new Windows forms application and name it as “Mdi\_Form”. A default Windows form will be displayed. Click on the Form Header and visit its properties window.

Step 2: Right click on Mdi\_Form in solution explorer and add two forms by clicking over ADD option therein and Name them Form2 and Form3 respectively.

Step 3: Customise each control pasted on the Form2 and Form3 as per the functions specified on labeled as show above. After customizing these form2.

‘From2.vb

‘Program to demonstrate the use of MDI Form to perform Addition operation

Public Class Child1\_form

Private Sub Label1\_Click(sender As Object, e As EventArgs) Handles Label1.Click

End Sub

Private Sub Button1\_Click(sender As Object, e As EventArgs) Handles Button1.Click

Dim sum As Integer

sum = Convert.ToInt32(TextBox1.Text) + Convert.ToInt32(TextBox2.Text)

TextBox3.Text = sum

End Sub

Private Sub Button2\_Click(sender As Object, e As EventArgs) Handles Button2.Click

TextBox1.Text = “ “

TextBox2.Text = “ “

TextBox3.Text = “ “

End Sub

End Class



## CHAPTER 3 APPLICATION WITH MULTIPLE FORMS

**R.SUGANYA**

*Assistant Professor, Department of Computer Science, Ponnaiah Ramajayam Institute of Science and Technology*

### **Properties**

The two properties involved are DragMode that specifies whether Automatic or Manual dragging will be used, and DragIcon that specifies which icon is displayed when the control is dragged.

### **Events**

It involves two events i.e. DragDrop, which happens when a control is lowered onto the target, and DragOver, which happens when a control is dragged over the object.

### **Method**

The Drag method starts or stops manual dragging.

```
Private MouseIsDown As Boolean = False 'variable declaration
```

```
Private Sub TextBox1_MouseDown (ByVal sender As Object, ByVal e As _  
System.Windows.Forms.MouseEventArgs) Handles TextBox1.MouseDown  
'Set a flag to show that the mouse is down.
```

```
MouseIsDown = True
```

```
End Sub
```

```
Private Sub TextBox1_MouseMove (ByVal sender As Object, ByVal e As _  
System.Windows.Forms.MouseEventArgs) H a n dl es TextBox1.MouseMove
```

```
If MouseIsDown Then
```

```
'Initiate dragging.
```

```
TextBox1.DoDragDrop(TextBox1.Text, DragDropEffects.Copy)
```

```
End If
```

```
MouseIsDown = False
```

```
End Sub
```

## CHAPTER 4 APPLICATIONS WITH DIALOGS

R.BANUMATHI

*Assistant Professor, Department of Computer Science, Ponnaiah Ramajayam Institute of Science and Technology*

### **ADO.NET Data Architecture**

#### **Connection**

It is used for establishing a connection between database and application. SqlConnection class is used for the MS-SQL database. OleDbConnection class is used for a database like an oracle and MS-Access.

#### **Command**

It is used to execute a command (Query). SqlCommand class is used for the MS-SQL database. OleDbCommand class is used for a database like an oracle and MS-Access.

#### **DataSet**

It provides a copy of the original database tables.

#### **DataAdapter**

It is used to retrieve data from the database and update DataSet. SqlDataAdapter class is used for the MS-SQL database. OleDbDataAdapter class is used for a database like an oracle and MS-Access.

### **Data Access with Server Explorer**

VB allows us to work with db in two ways i.e. visually and code. Server Explorer enables us to work with connections across different data sources visually. The window that is displayed is the Server Explorer that helps us to create and examine data connections. Server Explorer can be viewed by selecting View!Server Explorer from the main menu or by pressing Ctrl+Alt+S on the keyboard as shown below.

We will work with SQL Server, the default provider for .NET. We'll be displaying data from Customers table in sample Northwind database in SQL Server. It requires establishing a connection to this database. You need to right-click on the Data Connections icon in Server Explorer and select Add Connection item that opens the Data Link Properties dialog. It allows us to enter the name of the server with which we want to work along with login name and password as shown below

Now select Northwind database from the list. After that click on the Test Connection tab, If the connection is successful, a message "Test Connection Succeeded" is displayed. Click OK and close the Data Link Properties or add connection when connection to the database is set.

## CHAPTER 5 APPLICATION WITH MENUS

P.KARTHIK

*Assistant Professor, Department of Computer Science, Ponnaiah Ramajayam Institute of Science and Technology*

Public Class AddBooks

Public NameFrm, NameTo As String

Private Sub Button9\_Click(ByVal sender As System.Object, ByVal e As System.EventArgs) Handles Button9.Click

Me.Close()

End Sub

Private Sub AddBooks\_Load(ByVal sender As System.Object, ByVal e As System.EventArgs) Handles MyBase.Load

Call generateyear()

Call disablethem()

Call readData()

Call GroupID\_Combo()

End Sub

Sub GroupID\_Combo()

Try

If objcon.State = ConnectionState.Closed Then objcon.Open()

com = New OleDb.OleDbCommand("Select GroupID from GroupD", objcon)

dr = com.ExecuteReader

While dr.Read

ComboBox1.Items.Add(dr.Item(0))

End While

dr.Close()

objcon.Close()

Catch ex As Exception

End Try

End Sub

## CHAPTER 6 APPLICATIONS USING DATA CONTROLS

G.GAYATHRI

*Assistant Professor, Department of Computer Science, Ponnaiah Ramajayam Institute of Science and Technology*

Data Controls are used to create interfaces for manipulating and editing data from a data source. For example, TextBox or DropDownList can be used to display and/or edit data from a data source.

The data control can be used to perform the following tasks:

1. It is used for connecting to a database.
2. To open a specified database table.
3. For creating a virtual table based on a database query.
4. Passing database fields to other Visual Basic tools.
5. Adding/updating records.
6. Identify errors that may occur while accessing data.
7. Close the database connection.

### Creating the Database

Microsoft Access or SQL Server can be used to create your database. Following are steps for creating an SQL server database:

1. Open SQL Server Management Studio.
2. Right click on the folder named Databases and select New.
3. Give it a name of Students and click OK. After that you will now see Students in the list of databases.
4. Expand Students in the database list, and right click on Tables, then select New Table.
5. Enter the following fields in the table.
6. Click on the Save button and name your Table StudentInfo
7. In SQL Management Studio, click on New Query and write the following:

```
INSERT INTO [Students].[dbo].[StudentInfo]([StudentName],[StudentSurname]  
,[StudentNumber])
```

8. Click on Execute.

## CHAPTER 7 APPLICATIONS USING COMMON DIALOGS

R.KALAISELVI

*Assistant Professor, Department of Computer Science, Ponnaiah Ramajayam Institute of Science and Technology*

All Windows applications use standard dialog boxes for common operations. These dialog boxes are implemented as standard controls in the Toolbox. To use any of the common dialog controls in your interface, just place the appropriate control from the Dialog section of the Toolbox on your form and activate it from within your code by calling the ShowDialog method.

The Common Dialog control provides a standard set of dialog boxes for operations such as opening, saving, and printing files, as well as selecting colors and fonts and displaying help. Any six of the different dialog boxes can be displayed with just one Common Dialog control. A particular dialog box is displayed by using one of the six “Show...” methods of the Common Dialog control: ShowOpen, ShowSave, ShowPrinter, ShowColor, ShowFont, or ShowHelp.

**OpenFileDialog** : The OpenFileDialog control prompts the user to open a file and allows the user to select a file to open. The user can check if the file exists and then open it. The OpenFileDialog control class inherits from the abstract class FileDialog.

If the ShowReadOnly property is set to True, then a read-only check box appears in the dialog box. You can also set the ReadOnlyChecked property to True, so that the read-only check box appears checked.

Consider an example of loading an image file in a picture box, using the open file dialog box. Apply the following steps:

1. Drag and drop a PictureBox control, a Button control and OpenFileDialog control on the form.
2. Set the Text property of the button control to ‘Load Image File’
3. Double-click the Load Image File button and modify the code of the Click event as given below:

```
Private Sub Button1_Click(sender As Object, e As EventArgs) Handles Button1.Click
If OpenFileDialog1.ShowDialog <> Windows.Forms.DialogResult.Cancel Then
PictureBox1.Image = Image.FromFile (OpenFileDialog1.FileName)
End If
End Sub
```

**FontDialog**: It displays a dialog box that enables users to set a font and its attribute

It prompts the user to choose a font from among those installed on the local computer and lets the user select the font, font size, and color. It returns the Font and Color objects.

## CHAPTER 8 DRAG AND DROP EVENTS

P.SAKILA

*Assistant Professor, Department of Computer Science, Ponnaiah Ramajayam Institute of Science and Technology*

It is essentially a pointing interface gesture in the drag and drop case, in which the user selects a virtual object by “Grabbing” it and moving it to another position or to another virtual object.

You have certainly used drag and drop techniques as a Windows user to copy or transfer files from one folder to another, to remove a file by dragging it to the recycling bin, and to perform actions in different programs of the application. In Visual Basic, the drag-and-drop features allow you to integrate this functionality into the programs you are creating. The action of holding a mouse button down and moving a control is called dragging, and the action of releasing the button is called dropping.

Basically, a control may act as a source of a drag-and-drop process or as a destination. Visual Basic supports two drag-and-drop modes, automatic or manual. You only need to set a property in automatic mode at design time or at run time and let Visual Basic do it all. Conversely, in manual mode you have to respond to a number of events that occur while dragging is in progress, but in return you get better control over the process. To incorporate drag and drop functionality in your VB programs, you use a handful of properties, events, and methods.

### **Properties**

The two properties involved are DragMode that specifies whether Automatic or Manual dragging will be used, and DragIcon that specifies which icon is displayed when the control is dragged.

### **Events**

It involves two events i.e. DragDrop, which happens when a control is lowered onto the target, and DragOver, which happens when a control is dragged over the object.

### **Method**

The Drag method starts or stops manual dragging.

The GetDataPresent method checks the format of the data being dragged in case of DragEnter event. In our case it is text, so the Effect property is set to Copy, which in turn displays the copy cursor. The GetData method is used to retrieve the text from the DataObject. In case of DragDrop event it also assigns it to the target TextBox.

## CHAPTER 9 DATABASE MANAGEMENT

P.KARTHIKEYAN

*Assistant Professor, Department of Computer Science, Ponnaiah Ramajayam Institute of Science and Technology*

Database means a place where data can be stored in a structured manner. It is a shared collection or batch of data that is logically related, along with their descriptions designed to meet the information requirements of an organization.

Database Management System (DBMS) is a software system that allows users to not only define and create a database but also maintain it and control its access. A database management system can be called a collection of interrelated data (usually called database) and a collection or set of programs that helps in accessing, updating and managing that data (which form part of a database management system).

The primary benefit of using a DBMS is to impose a logical and structured organization on data. A DBMS provides simple mechanisms for processing huge volumes of data because it is optimized for operations of this type. The two basic operations performed by the DBMS are as follows:

1. Management of data in the database
2. Management of users associated with the database

Management of the data means specifying how data will be stored, structured and accessed in the database. This includes the following:

- Defining: Specifying data types and structures, and constraints for data to be stored.
- Constructing: Storing data in a storage medium.
- Manipulating: Involves querying, updating and generating reports.
- Sharing: Allowing multiple users and programs to access data simultaneously

Management of database users means managing the users in such a way that they are able to perform any desired operations on the database. A DBMS also ensures that a user cannot perform any operation for which he is not authorized.

1. Create an assembly (class library project) containing an item of type User Control.
2. Expose an interface for the control
3. Embed the user control into a web page.
4. Transfer data from a web form to the control and display the data on the control

## CHAPTER 10 CREATING ACTIVE X CONTROLS

R.SELVAKUMAR

*Assistant Professor, Department of Computer Science, Ponnaiah Ramajayam Institute of Science and Technology*

1. Create an assembly (class library project) containing an item of type User Control.
2. Expose an interface for the control
3. Embed the user control into a web page.
4. Transfer data from a web form to the control and display the data on the control.

First, we will create a simple ActiveX control to get an overall idea about how to create ActiveX controls.

Step 1: Create an assembly

Create a new project of type Class Library. Name the class library ActiveXDotNET

Delete the Class1.cs file from your project once the project is developed, as it won't be required. Next, by right-clicking the project in your Solution Explorer, add User Control to the project, select Add, then User Control. Name your control as "myControl".

On the user control, add some UI elements, and a text box control named txtUserText. The txtUserText control will display the user data that is typed into the web form. This will demonstrate how to pass data to your User Control.

When you are done adding your user interface to the control we now have to add a key element to the control, an Interface. The interface will allow COM/ COM+ objects to know what properties they can use. In this case, we are going to expose one public property named UserText. That property will allow us to set the value of the text box control.

Step 2: Expose the interface for the control

First, create a private String to hold the data passed from the web form to the control:

```
private Dim mStr_UserText as String
```

Place this String just inside the Class myControl.

Next, we will create a public property. The web page will use this property to pass text back to your control. This property will allow reading and writing of the value mStr\_UserText.

```
Public Property UserText() As [String]
```

```
Get
```

```
Return mStr_UserText
```

```
End Get
```





# CLASS IN **C++**

EDITED BY  
B.VATCHALA



978-93-6255-692-9

Computer Design

CopyRights@2018

B.Vatchala

All rights reserved.No part of this book may be reproduced or transmitted in any form or by any means without written permission from the author.

ISBN: 978-93-6255-692-9

Publisher: Ponnaiah Ramajayam Institute of Science and Technology[PRIST]

# Table of Contents

<b>Chapter I: C++ Classes</b>	.....	<b>1</b>
-------------------------------	-------	----------

Dr.K.Saravanan

<b>Chapter II: Defining a classes in c++</b>	.....	<b>2</b>
--	-------	----------

Dr.K.Raja

<b>Chapter III: Constructors and Destructors</b>	.....	<b>3</b>
--	-------	----------

R.Banumathi

<b>Chapter IV: Access Modifiers</b>	.....	<b>4</b>
-------------------------------------	-------	----------

Dr.S.R.Suresh

<b>Chapter V: Encaptulation</b>	.....	<b>5</b>
---------------------------------	-------	----------

R.Suganya

<b>Chapter VI: Inheirtance</b>	.....	<b>6</b>
--------------------------------	-------	----------

P.Karthikeyan

<b>Chapter VII: Polymorphism</b>	.....	<b>8</b>
----------------------------------	-------	----------

D.S.Chozhbharathi

## CHAPTER I: C++ Classes

**Dr.K.Saravanan**

*Professor,*

*Ponnaiyah Ramajayam Institute of science and Technology [PRIST],  
Thanjavur.*

A class is used to specify the form of an object and it combines data representation and methods for manipulating that data into one neat package. The data and functions within a class are called members of the class.

### C++ Class Definitions

When you define a class, you define a blueprint for a data type. This doesn't actually define any data, but it does define what the class name means, that is, what an object of the class will consist of and what operations can be performed on such an object.

A class definition starts with the keyword **class** followed by the class name; and the class body, enclosed by a pair of curly braces. A class definition must be followed either by a semicolon or a list of declarations. For example, we defined the Box data type using the keyword **class** as follows –

```
class Box {  
    public:  
        double length; // Length of a box  
        double breadth; // Breadth of a box  
        double height; // Height of a box  
};
```

The keyword **public** determines the access attributes of the members of the class that follows it. A public member can be accessed from outside the class anywhere within the scope of the class object. You can also specify the members of a class as **private** or **protected** which we will discuss in a sub-section.

A class is a blueprint for the object.

We can think of a class as a sketch (prototype) of a house.

It contains all the details about the floors, doors, windows, etc - we build the house based on these descriptions.

## CHAPTER II: Defining a Classes in c++

**Dr.K.Raja**

**Associate Professor,**

Ponnaiyah Ramajayam Institute of science and Technology [PRIST],  
Thanjavur.

A class provides the blueprints for objects, so basically an object is created from a class. We declare objects of a class with exactly the same sort of declaration that we declare variables of basic types. Following statements declare two objects of class Box.

Accessing the Data Members

The public data members of objects of a class can be accessed using the direct member access operator (.). Let us try the following example to make the things clear –

```
#include <iostream>
using namespace std;
class Box {
    public:
        double length; // Length of a box
        double breadth; // Breadth of a box
        double height; // Height of a box
};
int main()
{
    Box Box1;    // Declare Box1 of type Box
    Box Box2;    // Declare Box2 of type Box
    double volume = 0.0; // Store the volume of a box here
    // box 1 specification
    Box1.height = 5.0;
    Box1.length = 6.0;
    Box1.breadth = 7.0; // box 2 specification
    Box2.height = 10.0;
    Box2.length = 12.0;
    Box2.breadth = 13.0;
    // volume of box 1
    volume = Box1.height * Box1.length * Box1.breadth;
    cout << "Volume of Box1 : " << volume << endl;
    // volume of box 2
    volume = Box2.height * Box2.length * Box2.breadth;
    cout << "Volume of Box2 : " << volume << endl;
    return 0;
}
```

## CHAPTER III: Constructors and Destructors

**R.Banumathi**

**Associate Professor,**

Ponnaiyah Ramajayam Institute of science and Technology [PRIST],  
Thanjavur.

### **Understanding Constructors and Destructors in C++**

In object-oriented programming, particularly in C++, constructors and destructors play a crucial role in managing the lifecycle of objects. They are both special member functions of a class, but they serve opposite purposes.

#### **Constructors: Initializing Objects**

A constructor is a special function that has the same name as the class and is used to initialize objects. When you create an instance of a class, the constructor is automatically called, setting up the initial state of the object and allocating the necessary resources. Constructors can be overloaded, meaning you can have multiple constructors in a class with different parameters. They can also be default, parameterized, or copy constructors, each serving a different initialization purpose.

#### **Here's a simple example of a constructor in C++:**

```
class MyClass {  
public:  
MyClass() {  
// Constructor's body  
}  
};
```

#### **Destructors: Releasing Resources**

A destructor, on the other hand, is used to clean up when an object is no longer needed. It has the same name as the class but is preceded by a tilde (~). The destructor is automatically called when an object goes out of scope or is explicitly deleted. It's responsible for releasing any resources the object may have acquired during its lifetime. Unlike constructors, a class can only have one destructor, and it cannot be overloaded.

#### **Here's a simple example of a destructor in C++:**

```
class MyClass {  
public:  
~MyClass() {  
// Destructor's body  
}  
};
```

## CHAPTER IV: Access Specifiers

Dr. S.R.Suresh

Associate Professor,

Ponnaiyah Ramajayam Institute of science and Technology [PRIST],  
Thanjavur.

### Access Specifiers

The public keyword is an access specifier. Access specifiers define how the members (attributes and methods) of a class can be accessed. In the example above, the members are public - which means that they can be accessed and modified from outside the code.

However, what if we want members to be private and hidden from the outside world?

In C++, there are three access specifiers:

**public** - members are accessible from outside the class

**private** - members cannot be accessed (or viewed) from outside the class

**protected** - members cannot be accessed from outside the class, however, they can be accessed in inherited classes. You will learn more about Inheritance later.

```
class MyClass {
    public: // Public access specifier
        int x; // Public attribute
    private: // Private access specifier
        int y; // Private attribute
};

int main() {
    MyClass myObj;
    myObj.x = 25; // Allowed (public)
    myObj.y = 50; // Not allowed (private)
    return 0;
}
```

## CHAPTER V: Encapsulation

R.Suganya

Assistant Professor,

Ponnaiyah Ramajayam Institute of science and Technology [PRIST],  
Thanjavur.

**Encapsulation** is defined as binding together the data and the functions that manipulate them.

Two Important property of **Encapsulation**

**Data Protection:** Encapsulation protects the internal state of an object by keeping its data members private. Access to and modification of these data members is restricted to the class's public methods, ensuring controlled and secure data manipulation.

**Information Hiding:** Encapsulation hides the internal implementation details of a class from external code. Only the public interface of the class is accessible, providing abstraction and simplifying the usage of the class while allowing the internal implementation to be modified without impacting external code.

```
#include <iostream>
using namespace std;
class temp{
    int a;
int b;
public:
int solve(int input){
    a=input;
    b=a/2;
    return b;
}
};
int main() {
int n;
cin>>n;
temp half;
int ans=half.solve(n);
cout<<ans<<endl;

}
```



## CHAPTER VI: Inheritance

P.Karthikeyan

Associate Professor,

Ponnaiyah Ramajayam Institute of science and Technology [PRIST],  
Thanjavur.

When creating a class, instead of writing completely new data members and member functions, the programmer can designate that the new class should inherit the members of an existing class. This existing class is called the base class, and the new class is referred to as the derived class.

### Base and Derived Classes

A class can be derived from more than one classes, which means it can inherit data and functions from multiple base classes. To define a derived class, we use a class derivation list to specify the base class(es). A class derivation list names one or more base classes and has the form –

**class derived-class: access-specifier base-class**

Where access-specifier is one of public, protected, or private, and base-class is the name of a previously defined class. If the access-specifier is not used, then it is private by default. Consider a base class Shape and its derived class Rectangle as follows

```
#include <iostream>
using namespace std;
// Base class
class Shape {
public:
    void setWidth(int w) {
        width = w;
    }
    void setHeight(int h) {
        height = h;
    }
protected:
    int width;
```

## **CHAPTER VII: Polymorphism**

**D.S.Chozhabharathi**

**Assistant Professor,**

Ponnaiyah Ramajayam Institute of science and Technology [PRIST],  
Thanjavur.

The word “polymorphism” means having many forms. In simple words, we can define polymorphism as the ability of a message to be displayed in more than one form. This is called polymorphism.

### **Types of Polymorphism**

Compile-time Polymorphism

Runtime Polymorphism

#### **1. Compile-Time Polymorphism**

This type of polymorphism is achieved by function overloading or operator overloading.

##### **A. Function Overloading**

When there are multiple functions with the same name but different parameters, then the functions are said to be overloaded, hence this is known as Function Overloading. Functions can be overloaded by changing the number of arguments or/and changing the type of arguments. There are certain Rules of Function Overloading that should be followed while overloading a function.

##### **B. Operator Overloading**

C++ has the ability to provide the operators with a special meaning for a data type, this ability is known as operator overloading. So a single operator ‘+’, when placed between integer operands, adds them and when placed between string operands, concatenates them.

#### **2. Runtime Polymorphism**

This type of polymorphism is achieved by Function Overriding. The function call is resolved at runtime in runtime polymorphism

##### **A. Function Overriding**

Function Overriding occurs when a derived class has a definition for one of the member functions of the base class. That base function is said to be overridden.

##### **B. Virtual Function**

A virtual function is a member function that is declared in the base class using the keyword virtual and is re-defined (Overridden) in the derived class.



# FILEHANDLING IN **C**

*Edited by*  
**G.SANTHIYA JANCY**



978-93-6255-598-8

File Handling in C

CopyRights@2018

`G.Santhiya Jancy

All rights reserved.No part of this book may be reproduced or transmitted in any form or by any means without written permission from the author.

ISBN: 978-93-6255-590-8

Publisher: Ponnaiah Ramajayam Institute of Science and Technology[PRIST]

# Table of Contents

**Chapter I: File Handling in c Using File Pointers** ..... **1**

**Dr.S.Srinivasan**

**Chapter II: Open A File Using The Function fopen()** ..... **2**

**M.Aarthi**

**Chapter III: Close A File Using The Function Fclose()** ..... **3**

**G.Gayathri**

**Chapter IV: Character Input and Output in Files** ..... **4**

**P.Sakila**

**Chapter V: String Input/Output Functions** ..... **5**

**R.Kalaiselvi**

**Chapter VI: Formatted Input/Output Functions** ..... **6**

**R.Selvakumar**

**Chapter VII:Block Input/Output Functions** ..... **8**

**R.Banumathi**

## CHAPTER I: File Handling in c Using File Pointers

**Dr.S.Srinivasan**

*Associate Professor,*

*Ponnaiyah Ramajayam Institute of science and Technology [PRIST],*

*Thanjavur.*

As already mentioned in the above section, a sequential stream of bytes ending with an end-of-file marker is what is called a file. When the file is opened the stream is associated with the file. By default, three files and their streams are automatically opened when program execution begins - the standard input, standard output, and the standard error. Streams provide communication channels between files and programs.

For example, the standard input stream enables a program to read data from the keyboard, and the standard output stream enables to write data on the screen.

Opening a file returns a pointer to a FILE structure (defined in <stdio.h>) that contains information, such as size, current file pointer position, type of file etc., to perform operations on the file. This structure also contains an integer called a file

descriptor which is an index into the table maintained by the operating system namely, the open file table. Each element of this table contains a block called file control block (FCB) used by the operating system to administer a particular file.

The standard input, standard output and the standard error are manipulated using file pointers stdin, stdout and stderr. The set of functions which we are now going to discuss come under the category of buffered file system. This file system is referred to as buffered because, the routines maintain all the disk buffers required for reading / writing automatically.

To access any file, we need to declare a pointer to FILE structure and then associate it with the particular file. This pointer is referred as a file pointer and it is declared as follows:

```
FILE *fp;
```

## CHAPTER II: Open A File Using The Function fopen()

**M.Aarthi**

*Assistant Professor,*

*Ponnaiyah Ramajayam Institute of science and Technology [PRIST],*

*Thanjavur.*

Once a file pointer variables has been declared, the next step is to open a file. The fopen() function opens a stream for use and links a file with that stream. This function returns a file pointer, described in the previous section. The syntax is as follows:

```
FILE *fopen(char *filename,*mode);
```

where mode is a string, containing the desired open status. The filename must be a string of characters that provide a valid file name for the operating system and may include a path specification

The following code fragment explains how to open a file for reading.

```
Code Fragment 1 #include <stdio.h> main()
```

```
{
```

```
FILE *fp;
```

```
if ((fp=fopen("file1.dat", "r"))==NULL)
```

```
{
```

```
printf("FILE DOES NOT EXIST\n");
```

```
exit(0);
```

```
}
```

```
}
```

## CHAPTER III: Close A File Using The Function Fclose()

**G.Gayathri**

*Assistant Professor,*

*Ponnaiyah Ramajayam Institute of science and Technology [PRIST],*

*Thanjavur.*

When the processing of the file is finished, the file should be closed using the fclose() function, whose syntax is:

```
int fclose(FILE *fptr);
```

This function flushes any unwritten data for stream, discards any unread buffered input, frees any automatically allocated buffer, and then closes the stream. The return value is 0 if the file is closed successfully or a constant EOF, an end-of file marker, if an error occurred. This constant is also defined in <stdio.h>. If the function fclose() is not called explicitly, the operating system normally will close the file when the program execution terminates.

The following code fragment explains how to close a file.

```
# include <stdio.h> main()
{
FILE *fp;
if ((fp=fopen("file1.dat", "r"))==NULL)
{
printf("FILE DOES NOT EXIST\n");
exit(0);
}
/* close the file */ fclose(fp);
}
```

Once the file is closed, it cannot be used further. If required, it can be opened in same or another mode.



## CHAPTER IV: Character Input and Output in Files

**P.Sakila**

*Assistant Professor,*

*Ponnaiyah Ramajayam Institute of science and Technology [PRIST],*

*Thanjavur.*

ANSI C provides a set of functions for reading and writing character by character or one byte at a time. These functions are defined in the standard library. They are listed and described below:

- `getc()`
- `putc()`

`getc()` is used to read a character from a file and `putc()` is used to write a character to a file. Their syntax is as follows:

```
int putc(int ch, FILE *stream); int getc(FILE *stream);
```

The file pointer indicates the file to read from or write to. The character `ch` is formally called an integer in `putc()` function but only the low order byte is used. On success `putc()` returns a character (in integer form) written or EOF on failure. Similarly `getc()` returns an integer but only the low order byte is used. It returns EOF when end-of-file is reached. `getc()` and `putc()` are defined in `<stdio.h>` as macros not functions.

`fgetc()` and `fputc()`

Apart from the above two macros, C also defines equivalent functions to read / write characters from / to a file. These are:

```
int fgetc(FILE *stream);
```

```
int fputc(int c, FILE *stream);
```

To check the end of file, C includes the function `feof()` whose prototype is:

```
int feof(FILE *fp);
```

It returns 1 if end of file has been reached or 0 if not. The following code fragment explains the use of these functions.

## CHAPTER V: String Input/Output Functions

**R.Kalaiselvi**

*Assistant Professor,*

*Ponnaiyah Ramajayam Institute of science and Technology [PRIST],*

*Thanjavur.*

If we want to read a whole line in the file then each time we will need to call character input function, instead C provides some string input/output functions with the help of which we can read/write a set of characters at one time. These are defined in the standard library and are discussed below:

- fgets()
- fputs()

These functions are used to read and write strings. Their syntax is:

```
int fputs(char *str, FILE *stream);
```

```
char *fgets(char *str, int num, FILE *stream);
```

The integer parameter in fgets() is used to indicate that at most num-1 characters are to be read, terminating at end-of-file or end-of-line. The end-of-line character will be placed in the string str before the string terminator, if it is read. If end-of-file is encountered as the first character, EOF is returned, otherwise str is returned. The fputs() function returns a non-negative number or EOF if unsuccessful.

### Example

Write a program read a file and count the number of lines in the file, assuming that a line can contain at most 80 characters.

```
/*Program to read a file and count the number of lines in the file */ #include<stdio.h>
```

```
#include<conio.h> #include<process.h> void main()
```

```
{
```

```
FILE *fp;
```

```
int cnt=0; char str[80];
```

## CHAPTER VI: Formatted Input/Output Functions

**R.Selvakumar**

*Assistant Professor,*

*Ponnaiyah Ramajayam Institute of science and Technology [PRIST],*

*Thanjavur.*

If we want to read a whole line in the file then each time we will need to call character input function, instead C provides some string input/output functions with the help of which we can read/write a set of characters at one time. These are defined in the standard library and are discussed below:

- `fgets()`
- `fputs()`

These functions are used to read and write strings. Their syntax is:

```
int fputs(char *str, FILE *stream);
```

```
char *fgets(char *str, int num, FILE *stream);
```

The integer parameter in `fgets()` is used to indicate that at most `num-1` characters are to be read, terminating at end-of-file or end-of-line. The end-of-line character will be placed in the string `str` before the string terminator, if it is read. If end-of-file is encountered as the first character, EOF is returned, otherwise `str` is returned. The `fputs()` function returns a non-negative number or EOF if unsuccessful.

### Example

Write a program read a file and count the number of lines in the file, assuming that a line can contain at most 80 characters.

```
/*Program to read a file and count the number of lines in the file */ #include<stdio.h>
```

```
#include<conio.h> #include<process.h> void main()
```

```
{
```

```
FILE *fp;
```

```
int cnt=0; char str[80];
```

## CHAPTER VII: Block Input/Output Functions

**R.Banumathi**

*Assistant Professor,*

*Ponnaiyah Ramajayam Institute of science and Technology [PRIST],*

*Thanjavur.*

If the file contains data in the form of digits, real numbers, characters and strings, then character input/output functions are not enough as the values would be read in the form of characters. Also if we want to write data in some specific format to a file, then it is not possible with the above described functions. Hence C provides a set of formatted input/output functions. These are defined in standard library and are discussed below:

fscanf() and fprintf()

These functions are used for formatted input and output. These are identical to scanf() and printf() except that the first argument is a file pointer that specifies the file to be read or written, the second argument is the format string. The syntax for these functions is:

```
int fscanf(FILE *fp, char *format, . . .); int fprintf(FILE *fp, char *format, . . .);
```

Both these functions return an integer indicating the number of bytes actually read or written.

```
#include<stdio.h>
```

```
main()
```

```
{
```

```
int account; char name[30]; double bal; FILE *fp;
```

```
if((fp=fopen("bank.dat","r"))== NULL) printf("FILE not present \n");
```

```
else
```

```
do{
```

```
fscanf(fp,"%d%s%lf",&account,name,&bal); if(!feof(fp))
```

```
{
```

```
if(bal==0)
```

```
printf("%d %s %lf\n",account,name,bal);
```

```
}}while(!feof(fp));}
```



# **INFORMATION SECURITY**

EDITED BY  
**P.SAKILA**



Information Security

Copyright © 2018 by P.Sakila

All rights reserved. No part of this book may be reproduced or transmitted in any form or by any means without written permission from the author.

ISBN: 978-93-6255-807-7

Publisher: Ponnaiyah Ramajayam Institute of Science and Technology (PRIST)

## **TABLE OF CONTENTS**

CHAPTER 1 Basics of Information Security.....1	
<b>Dr.P.Sathya</b>	
CHAPTER 2 Threats & Attacks .....2	
<b>Dr.K.Raja</b>	
CHAPTER 3 Management in Security .....3	
<b>D.S.Chozha Bharathi</b>	
CHAPTER 4 Architectural Design in Security .....4	
<b>K.Priyadharshini</b>	
CHAPTER 5 Access Control & Security .....5	
<b>M.Aarthi</b>	
CHAPTER 6 Application Security .....6	
<b>P.Karthik</b>	
CHAPTER 7 Emerging Trends in Information Security .....7	
<b>G.Gayathri</b>	

**CHAPTER 1**  
**BASICS OF INFORMATION SECURITY**  
**DR.P.SATHYA**

Associate Professor, Department of Computer Science, Ponnaiyah Ramajayam Institute  
of Science and Technology, Tamil Nadu, India.

Information security is a critical discipline that focuses on protecting information and information systems from unauthorized access, disclosure, alteration, and destruction.

As organizations increasingly rely on digital technologies to store and process sensitive data, the importance of robust security measures becomes paramount.

This field encompasses a wide range of practices and technologies aimed at ensuring the confidentiality, integrity, and availability of information—commonly referred to as the CIA triad. Information security involves identifying potential threats, assessing vulnerabilities, and implementing appropriate controls to mitigate risks.

These controls may include firewalls, encryption, access controls, and security awareness training, all designed to safeguard data against various cyber threats such as malware, phishing, and insider attacks. Additionally, regulatory compliance plays a significant role in shaping security policies and practices, as organizations must adhere to laws and regulations that govern data protection.

The dynamic nature of the cybersecurity landscape necessitates continuous monitoring and adaptation to emerging threats.

Information security not only protects organizational assets but also fosters trust among users and stakeholders.

By promoting a culture of security awareness and employing proactive measures, organizations can better safeguard their information assets, ensuring resilience in an increasingly interconnected world. Information security is a multifaceted discipline focused on protecting sensitive data from unauthorized access, theft, alteration, and destruction.

With the rapid evolution of technology and the increasing prevalence of cyber threats, the importance of implementing robust security measures has never been more critical.

**Key Concepts**

**The CIA Triad:**

**Confidentiality:** Ensures that information is accessible only to those authorized to view it. Techniques include encryption and access controls.

**Integrity:** Protects data from being altered or tampered with, ensuring accuracy and reliability. Methods such as hashing and checksums are commonly used.

**Availability:** Ensures that information and resources are available to authorized users when needed. This involves implementing redundancy and disaster recovery plans.

**Types of Threats:**

**Malware:** Includes viruses, worms, and ransomware that can disrupt, damage, or gain unauthorized access to systems.

**Phishing:** Social engineering attacks that trick users into divulging sensitive information through deceptive emails or websites.

**Insider Threats:** Risks originating from within the organization, often from employees or contractors with access to sensitive data.

**Security Controls:**

**Preventive Controls:** Measures designed to prevent security incidents (e.g., firewalls, anti-virus software).

**Detective Controls:** Tools that monitor for suspicious activities and provide alerts (e.g., Intrusion Detection Systems).



**CHAPTER 2**  
**THREATS & ATTACKS**  
**DR.K.RAJA**

Associate Professor, Department of Computer Science, Ponnaiyah Ramajayam Institute  
of Science and Technology, Tamil Nadu, India.

In the realm of information security, threats and attacks pose significant risks to the confidentiality, integrity, and availability of data. As organizations increasingly rely on digital infrastructures, the variety and sophistication of threats have evolved, necessitating a deeper understanding of potential vulnerabilities and attack vectors.

Threats can be categorized into various types, including external threats such as malware, phishing, and denial-of-service (DoS) attacks, as well as internal threats stemming from insider negligence or malicious intent. Each of these threats exploits specific vulnerabilities within systems, applications, or human behavior, often leading to significant financial loss, reputational damage, and legal repercussions.

Understanding the tactics, techniques, and procedures (TTPs) employed by attackers is crucial for developing effective defense strategies. Common attacks include social engineering, ransomware, and zero-day exploits, each requiring tailored security measures to mitigate risks. Organizations must implement a multi-layered security approach, combining preventive, detective, and corrective controls, alongside regular training and awareness programs to empower users against potential threats.

As the cybersecurity landscape continues to evolve, organizations must remain vigilant and proactive in their security posture, adapting to new threats and ensuring resilience against attacks. This abstract underscores the importance of comprehensively addressing threats and attacks in information security to protect valuable assets and maintain trust in the digital age.

**Applications of Threats and Attacks in Information Security**

Understanding threats and attacks is crucial for developing effective security measures and enhancing overall cybersecurity posture. Here are some key applications of this knowledge:

**1. Risk Assessment and Management**

**Identifying Vulnerabilities:** Analyzing potential threats helps organizations identify weaknesses in their systems and processes, enabling them to prioritize security efforts.

**Risk Mitigation Strategies:** By understanding the nature of specific threats, organizations can develop targeted strategies to mitigate risks, such as implementing stronger access controls or enhanced monitoring.

**2. Incident Response Planning**

**Preparedness:** Knowledge of common threats informs the development of incident response plans, ensuring organizations are ready to respond swiftly and effectively to security incidents.

**Drills and Simulations:** Conducting tabletop exercises based on potential attack scenarios allows teams to practice their response and improve coordination during actual incidents.

**3. Security Policy Development**

**Policy Formulation:** Insights into threats and attack vectors guide the creation of comprehensive security policies that outline acceptable use, data protection, and incident reporting procedures.

**Compliance Requirements:** Understanding threats helps organizations align their security policies with regulatory requirements, ensuring compliance and reducing legal risks.

**4. Awareness and Training Programs**

**User Education:** Organizations can tailor security awareness training to educate employees about specific threats, such as phishing and social engineering, enhancing overall vigilance.

**Behavioral Change:** Training programs can foster a culture of security by encouraging employees to adopt safe practices and report suspicious activities.

**CHAPTER 3**  
**MANAGEMENT IN SECURITY**  
**D.S.CHOZHA BHARATHI**

Assistant Professor, Department of Computer Science, Ponnaiyah Ramajayam Institute  
of Science and Technology, Tamil Nadu, India.

Management in security encompasses the strategic planning, implementation, and oversight of practices designed to protect an organization's information assets from threats and vulnerabilities. As cyber threats continue to evolve and increase in complexity, effective security management has become essential for organizations aiming to safeguard their data, maintain operational integrity, and ensure compliance with regulatory requirements.

At the core of security management is the establishment of a comprehensive security framework that includes risk assessment, policy development, incident response, and continuous monitoring. This framework facilitates the identification of potential security risks and the implementation of appropriate controls to mitigate those risks. Additionally, it involves fostering a culture of security awareness among employees through training and education, ensuring that everyone understands their role in protecting sensitive information.

Leadership and governance are also crucial components of security management, as they set the tone for the organization's security posture. Executives and security leaders must prioritize security initiatives, allocate resources effectively, and engage in regular communication with stakeholders to align security objectives with business goals.

By integrating security management into the overall organizational strategy, businesses can enhance their resilience against cyber threats, protect their reputation, and achieve long-term success in an increasingly interconnected world. This abstract underscores the importance of effective management practices in addressing security challenges and promoting a proactive approach to information security.

**Applications of Management in Security**

Effective management in security plays a critical role in protecting an organization's information assets and enhancing its overall security posture. Here are some key applications:

**1. Risk Assessment and Management**

**Identifying Vulnerabilities:** Conducting regular risk assessments to identify potential threats and vulnerabilities within the organization.

**Prioritizing Risks:** Classifying risks based on their impact and likelihood, enabling informed decision-making regarding resource allocation and mitigation strategies.

**2. Policy Development and Implementation**

**Creating Security Policies:** Developing comprehensive security policies that outline acceptable use, data protection, and incident response procedures.

**Policy Enforcement:** Implementing mechanisms to ensure compliance with security policies across the organization, including regular audits and reviews.

**3. Incident Response Planning**

**Developing Response Plans:** Establishing clear incident response plans that outline roles, responsibilities, and procedures for addressing security incidents.

**Training and Drills:** Conducting regular training sessions and simulations to prepare staff for potential security breaches, ensuring a coordinated and effective response.

**4. Security Awareness and Training**

**Employee Education:** Implementing ongoing security awareness programs to educate employees about potential threats, safe practices, and their role in maintaining security.

**CHAPTER 4**  
**ARCHITECTURAL DESIGN IN SECURITY**  
**K.PRIYADHARSHINI**

Assistant Professor, Department of Computer Science, Ponnaiyah Ramajayam Institute  
of Science and Technology, Tamil Nadu, India.

**Architectural design** in security refers to the systematic approach of integrating security measures into the physical and digital frameworks of an organization. This discipline focuses on creating a robust infrastructure that not only safeguards sensitive data and assets but also supports operational efficiency and compliance with regulatory requirements.

Effective architectural design encompasses a holistic view, considering the interplay between physical security, network security, application security, and data protection. By employing principles such as defense in depth, segmentation, and least privilege, organizations can build resilient systems that mitigate risks and enhance their overall security posture.

**Key components of security architecture include** the use of firewalls, intrusion detection systems, and secure network configurations, alongside policies that govern access controls and data handling practices. Additionally, the architectural design must accommodate emerging technologies, such as cloud computing and the Internet of Things (IoT), ensuring that security measures evolve alongside technological advancements.

This abstract highlights the importance of architectural design in security as a foundational element in protecting organizational assets. By strategically integrating security into architectural frameworks, organizations can better defend against evolving threats, ensure continuity of operations, and maintain the trust of stakeholders in an increasingly complex digital landscape.

**Applications of Architectural Design in Security**

Architectural design in security plays a critical role in establishing a resilient and secure framework for organizations. Here are some key applications:

**1. Network Security Architecture**

**Segmentation and Zoning:** Dividing networks into distinct segments to contain potential breaches and limit lateral movement within the network.

**Firewalls and Intrusion Detection Systems (IDS):** Implementing firewalls to filter incoming and outgoing traffic and IDS to monitor for suspicious activities.

**2. Physical Security Integration**

**Access Control Systems:** Designing physical layouts that incorporate security measures like biometric scanners, key card systems, and surveillance cameras.

**Secure Facility Design:** Planning the physical architecture of buildings to protect sensitive areas, including data centers and server rooms, from unauthorized access.

**3. Cloud Security Architecture**

**Shared Responsibility Model:** Understanding the division of security responsibilities between the cloud service provider and the organization to ensure data protection.

**Secure Configuration:** Designing cloud environments with secure configurations, including identity and access management (IAM) and encryption of data at rest and in transit.

**4. Application Security Architecture**

**Secure Software Development Life Cycle (SDLC):** Incorporating security practices into each phase of application development to identify and mitigate vulnerabilities early.

**API Security:** Designing secure application programming interfaces (APIs) with authentication, authorization, and data validation to prevent unauthorized access.

**CHAPTER 5**  
**ACCESS CONTROL & SECURITY**  
**M.AARTHI**

Assistant Professor, Department of Computer Science, Ponnaiyah Ramajayam Institute  
of Science and Technology, Tamil Nadu, India.

**Access control and security** are critical components in safeguarding sensitive information and ensuring the integrity of systems in various environments, from corporate networks to personal devices.

This paper examines the fundamental principles of access control mechanisms, including authentication, authorization, and accountability, while also exploring their implementation in both physical and digital contexts.

We analyze various access control models—such as discretionary access control (DAC), mandatory access control (MAC), and role-based access control (RBAC)—highlighting their strengths and weaknesses in different scenarios. Furthermore, we discuss the evolving landscape of security threats and the importance of adaptive security measures that incorporate machine learning and behavioral analytics to enhance traditional access control strategies.

By integrating these approaches, organizations can improve their resilience against unauthorized access and data breaches, ultimately fostering a more secure operational environment.

The paper concludes with recommendations for best practices in access control implementation, emphasizing the need for a holistic security framework that balances usability and protection.

Access control and security are fundamental elements of information security, aimed at protecting sensitive data and ensuring that only authorized individuals have access to resources. Here's an overview of key concepts, mechanisms, and their significance.

**Key Concepts**

**Access Control:**

Definition: A set of policies and technologies that regulate who can access specific resources and what actions they can perform.

Objectives: To prevent unauthorized access, ensure data integrity, and protect confidential information.

**Security:**

Definition: The measures taken to protect systems, networks, and data from threats, including unauthorized access, breaches, and attacks.

Scope: Encompasses both physical security (e.g., locks, surveillance) and cyber security (e.g., firewalls, encryption).

**Core Components**

**Authentication:**

The process of verifying the identity of a user or device. Common methods include passwords, biometrics, and multi-factor authentication (MFA).

**Authorization:**

Determines what an authenticated user is allowed to do. It involves assigning permissions based on roles, attributes, or policies.

**Accountability:**

Ensures that actions taken on a system can be traced back to a specific user. This is often implemented through logging and auditing mechanisms.

**CHAPTER 6**  
**APPLICATION SECURITY**  
**P.KARTHIK**

Assistant Professor, Department of Computer Science, Ponnaiyah Ramajayam Institute  
of Science and Technology, Tamil Nadu, India.

**Application security** is a critical aspect of cyber security that focuses on protecting applications from vulnerabilities and threats throughout their development lifecycle.

As organizations increasingly rely on software applications to drive business operations, the potential for exploitation by malicious actors has grown.

This paper explores the fundamental principles of application security, including threat modeling, secure coding practices, and security testing methodologies such as static and dynamic analysis. We highlight common vulnerabilities, including SQL injection, cross-site scripting (XSS), and insecure authentication mechanisms, drawing attention to the importance of addressing these issues early in the development process.

Furthermore, we discuss the integration of security into DevOps practices (DevSecOps) to promote a culture of security awareness among developers and stakeholders.

By adopting a proactive approach to application security, organizations can enhance their resilience against cyber threats, protect sensitive data, and ensure compliance with regulatory requirements.

**Uses of Application Security**

Application security encompasses a range of practices and tools designed to protect applications from threats and vulnerabilities. Here are some key uses:

**Protecting Sensitive Data:**

Safeguards personally identifiable information (PII), financial data, and proprietary business information from unauthorized access and breaches.

**Preventing Cyber Attacks:**

Mitigates risks from common attack vectors such as SQL injection, cross-site scripting (XSS), and denial-of-service (DoS) attacks, reducing the likelihood of exploitation.

**Ensuring Compliance:**

Helps organizations adhere to regulatory requirements (e.g., GDPR, HIPAA, PCI-DSS) that mandate specific security measures for protecting sensitive information.

**Enhancing Software Integrity:**

Validates that applications function as intended without vulnerabilities, thus maintaining the integrity and reliability of software systems.

**Securing APIs:**

Protects application programming interfaces (APIs) from abuse and ensures that only authorized users can access backend services, crucial for modern web and mobile applications.

**Implementing Secure Development Practices:**

Promotes secure coding standards and practices among developers to prevent vulnerabilities from being introduced during the software development lifecycle (SDLC).

**Facilitating Continuous Security:**

Integrates security testing and monitoring throughout the development process (DevSecOps), allowing for timely identification and remediation of security issues.

## **CHAPTER 7**

### **EMERGING TRENDS IN INFORMATION SECURITY**

**G.GAYATHRI**

Assistant Professor, Department of Computer Science, Ponnaiyah Ramajayam Institute  
of Science and Technology, Tamil Nadu, India.

As the digital landscape evolves, information security is increasingly challenged by sophisticated cyber threats and the rapid adoption of new technologies.

This paper explores emerging trends in information security, highlighting key developments such as the rise of artificial intelligence (AI) and machine learning for threat detection and response, the growing importance of zero trust architecture, and the integration of security into DevOps practices (DevSecOps).

Additionally, we examine the implications of regulatory changes, such as GDPR and CCPA, which drive organizations to enhance their data protection measures.

The proliferation of Internet of Things (IoT) devices and the shift to cloud-based solutions further complicate security landscapes, necessitating innovative approaches to safeguard sensitive information.

The paper concludes by discussing best practices for organizations to stay ahead of evolving threats, emphasizing the need for continuous education, adaptive security frameworks, and collaboration across industries to build a resilient cyber security posture in an increasingly interconnected world.

#### **Overview of Emerging Trends in Information Security**

The field of information security is rapidly evolving to address the complexities and challenges posed by new technologies and sophisticated cyber threats. Here are some key emerging trends shaping the future of information security:

##### **1. Artificial Intelligence and Machine Learning**

**Threat Detection:** AI and machine learning algorithms are increasingly used to analyze vast amounts of data for patterns indicative of security breaches. These technologies enhance threat detection and response capabilities.

**Automated Responses:** Automation of security responses allows organizations to react swiftly to incidents, reducing the potential impact of attacks.

##### **2. Zero Trust Architecture**

**Principle of Least Privilege:** Zero trust emphasizes that no user or device should be trusted by default, regardless of their location. Access is granted based on continuous verification of identity and context.

**Micro-Segmentation:** This approach divides networks into smaller segments, limiting lateral movement by attackers and containing breaches more effectively.

##### **3. Cloud Security**

**Shared Responsibility Model:** As organizations increasingly adopt cloud services, understanding the shared responsibility for security between cloud providers and users is crucial.

**Cloud Access Security Brokers (CASBs):** These solutions provide visibility and control over data stored in cloud applications, helping to enforce security policies.

##### **4. IoT Security**

**Increased Vulnerabilities:** The proliferation of Internet of Things (IoT) devices introduces new security challenges, as many devices lack robust security measures.

**Security Frameworks:** Organizations are developing frameworks and standards to secure IoT devices and ensure their safe integration into existing networks.

##### **5. Regulatory Compliance**

**Data Protection Regulations:** Laws such as GDPR and CCPA are prompting organizations to enhance their data protection strategies and adopt proactive security measures to comply with stringent regulations.



# **CLOUD** **TECHNOLOGY**



Edited by  
**MR.K.UMASHANKAR**



978-93-6255-784-1

## CLOUD TECHNOLOGY

Copyright@ 2018 by Mr.K.Umashankar

All rights reserved. No part of this book may be reproduced or transmitted in any form or by any means without written permission from the author.

ISBN: 978-93-6255-784-1

Publisher: Ponnaiah Ramajayam Institute of Science and Technology[PRIST]



## TABLE OF CONTENTS

CHAPTER 1: Navigating the Cloud: Architecture, Security, and Compliance in the Modern Computing Landscape.....	1
D.S.Chozhabharathi	
CHAPTER 2: Securing Access: A Comprehensive Guide to Identity and Access Management in the Cloud, Featuring IAM Best Practices and Case Studies .....	2
R. Suganya	
CHAPTER 3: Securing the Cloud Journey: Navigating On-Prem to Cloud Migration, Integration, and Best Practices for Cloud Configuration Management .....	3
R. Banumathi	
CHAPTER 4: Guardians of Data: Strategies and Best Practices for Securing Cloud Data, Encryption, and Key Management.....	6
R. Banumathi	
CHAPTER 5: Securing Cloud Applications: From Development Basics to DevSecOps Practices and the OWSAP Top 10.....	8
R. Idayathulla	
CHAPTER 6: Multifaceted Web Crafting: From Stylish Typography to Dynamic Functionality.....	10
M. Aarthi	
CHAPTER 7: Improving Cloud Security.....	12
P. Karthik	
CHAPTER 8: Managing Cloud Workload and Service.....	13.
G. Gayathri	
CHAPTER 9: Transforming IT with Cloud.....	15
R. Rajayogeswari	

## CHAPTER- 1

### Navigating the Cloud: Architecture, Security, and Compliance in the Modern Computing Landscape

D.S.Chozhabharathi

(Assistant Professor, Department of Computer science, Ponnaiah Ramajayam  
Institute of Science and Technology[PRIST], Thanjavur.)

Cloud architecture is a key element of building in the cloud. It refers to the layout and connects all the necessary components and technologies required for [cloud computing](#).

Migrating to the cloud can offer many business benefits compared to on-premises environments, from improved agility and scalability to cost efficiency. While many organizations may start with a “lift-and-shift” approach, where on-premises applications are moved over with minimal modifications, ultimately it will be necessary to construct and deploy applications according to the needs and requirements of cloud environments.

#### **Cloud architecture defined**

Cloud architecture refers to how various cloud technology components, such as hardware, virtual resources, software capabilities, and virtual network systems interact and connect to create cloud computing environments. It acts as a blueprint that defines the best way to strategically combine resources to build a cloud environment for a specific business need.

Cloud architecture components include:

- A frontend platform
- A backend platform
- A cloud-based delivery model
- A network (internet, intranet, or intercloud)

In cloud computing, frontend platforms contain the client infrastructure—user interfaces, client-side applications, and the client device or network that enables users to interact with and access cloud computing services. For example, you can open the web browser on your mobile phone and edit a Google Doc.

## CHAPTER- 2

# Securing Access: A Comprehensive Guide to Identity and Access Management in the Cloud, Featuring IAM Best Practices and Case Studies.

R. Suganya

(Assistant Professor, Department of Computer science, Ponnaiah Ramajayam Institute of Science and Technology[PRIST], Thanjavur.)

Access Management delivers risk-aware, end-to-end multifactor authentication (MFA) and single sign-on (SSO) that integrates identities and systems across the cloud and on-premises. With access management, organizations gain flexibility to control access for existing enterprise platforms and support migration to cloud. Access management ensures policies follow the user regardless of the device and location to secure access to data anywhere, anytime, from any device. Access management features provide adaptive authentication reducing the risk by increasing login requirements for users based on device, location, and behavior when access is deemed high-risk. These context-aware policies and authorization capabilities are designed to address security threats to business-critical data.

### **Directory services**

Directory Services provide multiple deployment options and allow ISVs to bundle the directory into their applications. A unified directory provides elastic scalability to support growth without unnecessary over-provisioning, and easily expands without impacting the existing service. Directory services provide architectural flexibility and optimization, accelerate identity management projects and applications deployments and reduce total cost of ownership.

### **IAM**

IAM is a critical tool for protecting enterprise resources against cybersecurity threats. IAM systems ensure consistency of user access rules and policies across an organization, while also ensuring entitlements to resources are accurately applied as users change roles within the organization. Without automated monitoring of resources and activity, organizations become vulnerable to compromised users and data breaches. This is often at risk due to challenges of over-privileged access rights that have not been effectively managed. It is an essential tool for cloud environments to help manage the consistency of access between on-premises data centers and numerous cloud services. To prevent against identity-based attacks, organizations need an IAM strategy to enable greater visibility into company users and activity.

## CHAPTER- 3

# Securing the Cloud Journey: Navigating On-Prem to Cloud Migration, Integration, and Best Practices for Cloud Configuration Management

R. Banumathi

(Assistant Professor, Department of Computer science, Ponnaiah Ramajayam Institute of Science and Technology[PRIST], Thanjavur.)

### **Cloud migration**

[Cloud migration](#) is the process of moving applications, data, infrastructure, security, and other objects to a cloud computing environment.

Typically, companies are moving data, applications, and IT workloads from on-premises servers to the public cloud, but cloud migration also includes moving data and applications from one cloud provider to another.

Once migrated, systems might remain as is, or go through ongoing optimization and modernization. Cloud migration can also work in the reverse, from a cloud provider back to on-premises servers.

Why migrate to the cloud?

Some of the biggest reasons to migrate to the cloud are to reduce costs and optimize infrastructure. Migrating to the cloud can help organizations move spending from a capital expenditure model to an operational expenditure model, reducing the need to own, operate, maintain, and refresh expensive equipment in on-premises data centers.

Migrating to the cloud can help companies improve performance and increase uptime. The cloud also helps companies modernize workloads, avoiding burdensome licensing fees from legacy applications. The cloud can help organizations safeguard their data while increasing governance and compliance with regulators across the globe.

Organizations also migrate to the cloud to:

### **Unlock data analytics**

Migrating existing apps to the cloud can help businesses create more value out of tools they already use, such as CRM, SAP, marketing databases, and more. Getting these systems modernized in the cloud helps companies unlock their data and find new business opportunities while increasing organizational agility to address problems.

## CHAPTER- 4

### Guardians of Data: Strategies and Best Practices for Securing Cloud Data, Encryption, and Key Management

R. Banumathi

(Assistant Professor, Department of Computer science, Ponnaiah Ramajayam  
Institute of Science and Technology[PRIST], Thanjavur.)

Cloud encryption is a data security process in which plaintext data is encoded into unreadable cipher text to help keep it secure in or between cloud environments. It is one of the most effective ways to uphold data privacy as well as protect cloud data in transit or at rest against cyberattacks. Anywhere, anytime access to apps and data is a key advantage of the cloud, but such ubiquitous access—often to sensitive data—requires strong data protection, of which cloud encryption is a crucial part.

Cloud encryption protects sensitive information as it traverses the internet or rests in the cloud. Encryption algorithms can transform data of any type into an encoded format that requires a decryption key to decipher. This way, even if an attacker intercepts or exfiltrates the data, it's useless to them unless they can decrypt it.

Cloud encryption protects data in two basic states:

Data in transit between destinations, often outside a secure network, making it more vulnerable.

Data at rest in cloud storage, a data center server, or similar, and not being used or moved.

Today, standard HTTPS web traffic encryption uses Transport Layer Security (TLS; aka SSL) protocol to secure each data packet. When trusted users or entities (established through multifactor authentication) request access to encrypted data, they receive it in its encrypted state and must use a decryption key to render it usable.

#### Two Basic Types of Data Encryption

All cloud encryption services and protocols fall into two main categories: symmetric and asymmetric encryption.

CHAPTER- 5  
Securing Cloud Applications: From Development Basics to DevSecOps Practices  
and the OWSAP Top 10

R. Idayathulla

(Assistant Professor, Department of Computer science, Ponnaiah Ramajayam  
Institute of Science and Technology[PRIST], Thanjavur.)

The Open Worldwide Application Security Project (OWASP) is an essential resource for developers, particularly those working with cloud-based systems. As cloud computing continues to dominate the tech landscape, understanding the security challenges and solutions in this environment is crucial. This article, focusing on OWASP's contributions to cloud application security in 2024, offers vital insights into how developers can fortify their cloud applications against emerging threats.

#### Comprehensive Cloud Application Security Practices

OWASP emphasizes a holistic approach to cloud application security, advocating for measures that span the entire development lifecycle—from planning and design to deployment and maintenance. This comprehensive approach is crucial for cloud environments where integrating third-party services and APIs adds complexity and potential vulnerabilities.

#### Special Focus on APIs

Given APIs' foundational role in cloud applications, OWASP has spotlighted API security. API vulnerabilities can critically affect customer-facing, partner-facing, and internal web and mobile applications, as they play a crucial role in facilitating communication and data exchange. APIs inherently expose application logic and sensitive data, including Personally Identifiable Information (PII), making them prime targets for attackers in cloud environments. OWASP offers guidelines and tools to help developers implement robust authentication, encryption, and access control measures tailored to API security.

#### OWASP Resources for Cloud Application Security Developers

Developers should pay particular attention to the following OWASP resources that are useful for enhancing cloud application security:

## CHAPTER- 6

### Multifaceted Web Crafting: From Stylish Typography to Dynamic Functionality

M. Aarthi

(Assistant Professor, Department of Computer science, Ponnaiah Ramajayam  
Institute of Science and Technology[PRIST], Thanjavur.)

Cloud has captured the attention of business leaders with its distinctive capabilities of revitalizing antiquated technology stacks. It infused a new life into legacy IT infrastructures and created anything-as-a-service (XaaS) with tools that can be delivered to users as a service over the internet. The software and applications born in the cloud, also called cloud-native, yield agility, scalability, experience improvement, reusability, cost-efficiency, and security benefits.

#### **Navigating cloud migration challenges for a seamless transition**

To capitalize upon cloud's potential for digital transformation, enterprises must overcome the typical obstacles associated with its management.

#### **The key challenges include:**

- 1. Lack of cloud migration strategy:** The advantages of cloud transformation come with judicious design and planning whereby an organisation must select the right data and applications to be moved to the platform. It is also essential to strategize the order of migration for business assets. Failure to consider the integration issues between various datasets and applications can result in data loss and accessibility issues.
- 2. Existing architecture complexities:** Not all on-prem systems are compatible with the cloud, which can lead to data corruption during migration. Specific tools may need to be collocated to function effectively. However, a complex architecture and unstructured data make it challenging to identify interdependencies. Additionally, highly customized legacy setups demand more effort for successful cloud migration.

## CHAPTER- 7

### Improving Cloud Security

P. Karthik

(Assistant Professor, Department of Computer science, Ponnaiah Ramajayam  
Institute of Science and Technology[PRIST], Thanjavur.)

#### **Cloud Security**

To safeguard your cloud-based applications and systems, cloud security entails a combination of policies, controls, procedures, and technologies.

As remote work becomes more common, businesses are opting to store their sensitive data in the cloud. It's critical to understand that every business, big or small, has valuable information stored in cloud-based applications, making them vulnerable to cyberattacks.

And as more employees rely on personal and business devices for remote work, companies are at a higher risk of cyber attacks, which can take advantage of vulnerabilities and expand the "attack surface" of a business.

This creates more opportunities for hackers to strike and highlights the importance of mobile device security, especially when accessing cloud apps like Microsoft 365, Google apps and more.

Mobile device security is of particular importance. Many companies may have some sort of monitoring and management in place for corporate-supplied computers, but very few are on top of managing employee-owned mobile devices.

The trend of Bring-Your-Own Device (BYOD) has become increasingly popular among employees who use their personal devices to access cloud applications like Microsoft 365. However, this convenience comes at a cost, as it elevates the risks associated with cloud security.

In a recent advisory, CISA (Cybersecurity and Infrastructure Security Agency) revealed that hackers have been employing successful phishing campaigns and brute force logins to exploit weaknesses in cloud security practices.

Attackers deploy emails with malicious links to try and capture login credentials for cloud service accounts. The emails look legitimate, as do the links, tricking employees with these sophisticated phishing schemes.

Unfortunately, it often comes down to weak cyber hygiene habits in a company that opens the doors to hackers.



## CHAPTER- 8

### Managing Cloud Workload and Service

G. Gayathri

(Assistant Professor, Department of Computer science, Ponnaiah Ramajayam  
Institute of Science and Technology[PRIST], Thanjavur.)

#### **Cloud Workloads**

A cloud workload refers to the computing resources and tasks that are required to run an application or service in a cloud computing environment. This can include resources such as virtual machines, storage, and networking, as well as the software and applications that run on those resources.

Cloud workloads are typically managed and scaled using cloud-native tools and services, such as Kubernetes, a container orchestrator, or tools provided by cloud providers like Amazon Web Services, Microsoft Azure, and Google Cloud.

#### **Types of Workloads in the Cloud Classifying Workloads by Cloud Deployment Model**

There are three main types of cloud workloads, classified according to the cloud deployment model:

**Infrastructure as a Service (IaaS):** IaaS is a cloud computing model where the cloud provider offers virtualized computing resources, such as virtual machines (VMs), storage, and networking, over the internet. IaaS is suitable for hosting and managing infrastructure-level workloads, such as operating systems, databases, and storage.

**Platform as a Service (PaaS):** PaaS is a cloud computing model that provides a platform for developing, running, and managing applications, without having to worry about the underlying infrastructure. PaaS is suitable for hosting and managing application-level workloads, such as web and mobile applications.

**Software as a Service (SaaS):** SaaS is a cloud computing model where the cloud provider offers a complete software solution over the internet, typically on a subscription basis. SaaS is suitable for hosting and managing software-level workloads, such as email, customer relationship management (CRM), and human resource management (HRM) systems.

Each of these cloud deployment models provides different levels of control and customization to organizations, and choosing the right one depends on the specific requirements of the workloads being hosted.

## CHAPTER- 9

# Transforming IT with Cloud

R. Rajayogeswari

(Assistant Professor, Department of Computer science, Ponnaiah Ramajayam  
Institute of Science and Technology[PRIST], Thanjavur.)

### Introduction

Cloud transformation is a critical necessity and a complex journey filled with challenges. Moving from traditional on-premises infrastructure to the cloud requires careful planning to avoid compatibility issues, security risks, and cost overruns. Cloud transformation is essential as it empowers businesses to scale, collaborate seamlessly, enhance disaster recovery, and reduce costs. Moreover, 90% of companies are already on the cloud. It enables agility, rapid adaptation to market changes, and access to cutting-edge innovations without managing on-premises infrastructure. This thorough Cloud Transformation Guide will lead you through the critical phases of reviewing your present IT infrastructure, selecting the proper cloud provider, optimizing costs, assuring security, and deploying cloud-native technology. Real-world case studies will give invaluable insights, supporting your successful cloud transition path. What is

### Cloud Transformation

The notion of cloud computing is central to cloud transformation. In essence, cloud computing allows you to access and control computer resources like servers, databases, storage, and other resources over the internet. Therefore, on-prem infrastructure is no longer required; businesses can scale up or down your data with a few clicks. Cloud services come in various types to meet the demands of diverse businesses.

IaaS (Infrastructure as a Service) provides the required raw computer power.

Platform as a Service (PaaS) is a cloud-based platform for developing and delivering applications.

Software as a Service (SaaS) is a cloud-based delivery of ready-to-use software applications.

Businesses that opt for Cloud transformation save costs, can quickly scale, and do seamless collaboration and disaster recovery. It enables you to remain nimble, adapt rapidly to market developments, and leverage cutting-edge technology without managing on-premises infrastructure.



# DATA STRUCTURE AND ALGORITHMS

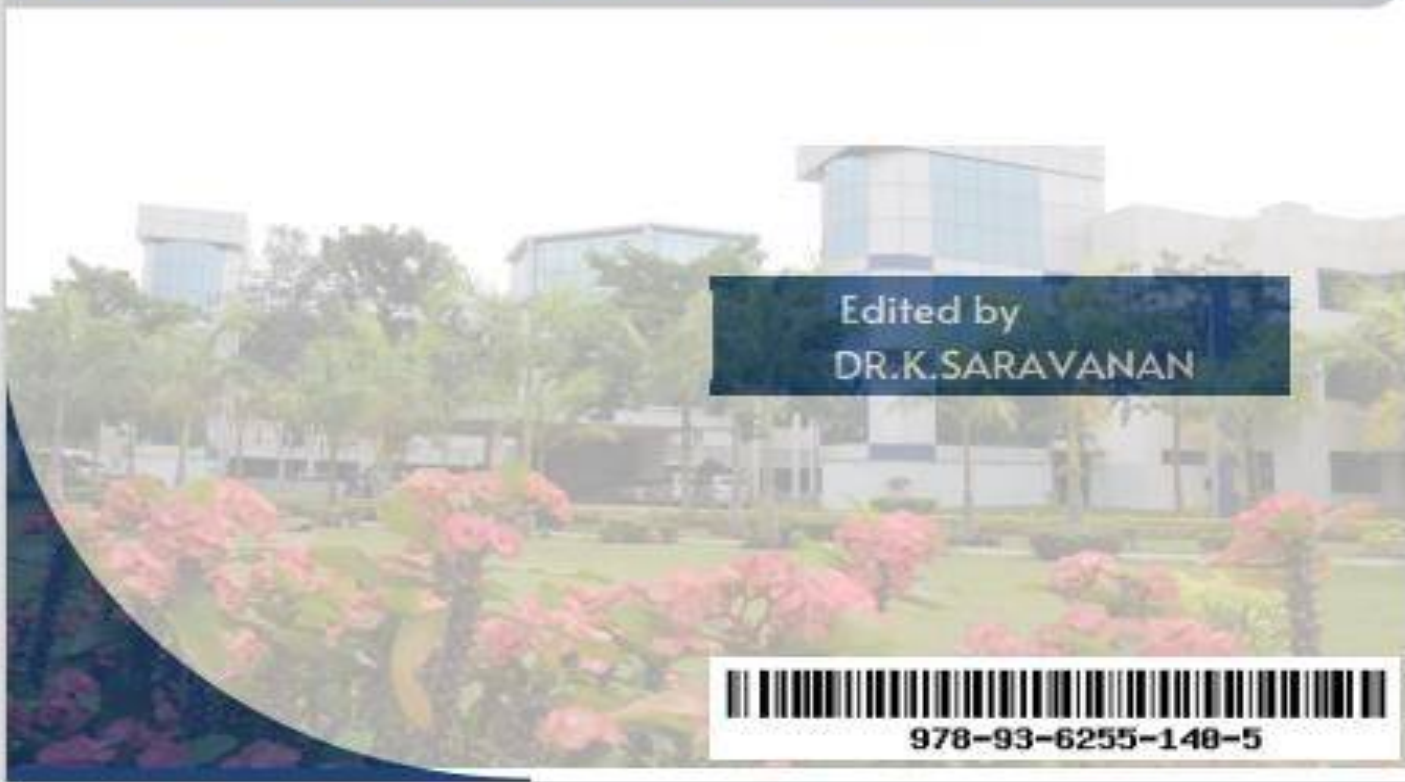

Edited by  
DR.K.SARAVANAN



978-93-6255-148-5

# DATASTRUCTURES & ALGORITHMS

Copyright@ 2018 by DR.K. Saravanan

All rights reserved. No part of this book may be reproduced or transmitted in any form or by any means without written permission from the author.

ISBN: 978-93-6255-140-5

Publisher: Ponnaiah Ramajayam Institute of Science and Technology[PRIST]

## TABLE OF CONTENTS

CHAPTER 1: "Foundations of Algorithms and Data Structures: Navigating Complexity and Efficiency".....	1
Dr.K. Raja	
CHAPTER 2: "Traversal, Search, and Divide-and-Conquer Mastery: Unlocking Efficient Algorithms for Trees and Sorting".....	4
DR.N. Jayashri	
CHAPTER 3: Greedy Method.....	6
R. Banumathi	
CHAPTER 4: "Dynamic Programming and Optimization Strategies: Solving Multistage Problems, Shortest Paths, and Combinatorial Challenges” .....	8
R. Idayathulla	
CHAPTER 5: "Exploring Backtracking and Branch-and-Bound: Solutions to N-Queens, Subset Sums, Graph Coloring, and the Traveling Salesperson Problem.....	9
M. Aarthi	
CHAPTER 6: Algorithm Design Techniques.....	10
P. Karthik	
CHAPTER 7: Dynamic Strategies.....	12
G. Gayathri	
CHAPTER 8: Master Theorem.....	14
R. Rajayogeswari	
CHAPTER 9: String Algorithms.....	16
P. Sakila	
CHAPTER 10: Medians of Median Algorithm.....	18
P. Karthikeyan	

# CHAPTER 1

Foundations of Algorithms and Data Structures:

“Navigating Complexity and Efficiency”

Dr.K. Raja

(Assistant Professor, Department of Computer science, Ponnaiah Ramajayam Institute of Science and Technology[PRIST], Thanjavur.)

## Complexity Analysis of Data Structures and Algorithms: An Overview

Complexity analysis is defined as a technique to measure how long an algorithm would take to complete given an input of size  $n$ ; independent of the machine, language, and compiler. It is used for evaluating the variations of execution time on different algorithms. While complexity is usually in terms of time, it is also analyzed in terms of space i.e. algorithm's memory requirements.

### Complexity Analysis is Required

- It gives you an estimated time and space required to execute a program.
- It is used for comparing different algorithms for different input sizes.
- It helps to determine the difficulty of a problem.

### Asymptotic Notations for Determining Complexities

Your algorithm doesn't need to behave in the same way for different input sizes. Its performance may vary. The study of the variations in the performance of the algorithm with the change in the order of the input size is called **Asymptotic Analysis**.

**Asymptotic notations** are mathematical notations to describe the running time of an algorithm when the input tends towards a particular value or a limiting value. In other words, it defines the mathematical limits of its run-time performance. Using the asymptotic analysis, we can easily conclude the average-case, best-case, and worst-case scenario of an algorithm.

There are mainly three asymptotic notations for the complexity analysis of algorithms. They are as follows:

1. Big-O notation
2. Omega notation
3. Theta notation

## CHAPTER -2

Traversal, Search, and Divide-and-Conquer Mastery:  
"Unlocking Efficient Algorithms for Trees and Sorting"

DR.N. Jayashri

(Assistant Professor, Department of Computer science, Ponnaiah Ramajayam Institute of Science and Technology[PRIST], Thanjavur.)

### Introduction

Have you ever wondered how computer programs solve complex problems so quickly? Or why some software seems faster than others. The secret lies in the use of efficient algorithms.

### What is an Algorithm?

Before we discuss algorithm efficiency, it's essential to understand what an algorithm is.

An algorithm is a step-by-step procedure or set of instructions for performing specific task or solving a particular problem. In computer science, algorithms are used to manipulate data in various data structures, such as arrays, linked lists, and trees, among others.

### Understanding Algorithm Efficiency

The term "algorithm efficiency" refers to the measure of how well an algorithm performs with respect to time and other resources required to complete its task. It is crucial because it determines the speed at which an algorithm can solve a problem, thus affecting the overall performance of the software using that algorithm.

### How to Measure Algorithm Efficiency

There are two primary ways to measure algorithm efficiency:

1. **Time complexity:** This is the amount of time an algorithm takes to complete its task, usually expressed as a function of the input size. It is typically represented using Big O notation, which allows us to compare the growth rates of different algorithms. For example, an algorithm with time complexity  $O(n)$  grows linearly with the input size, while another with time complexity  $O(\log n)$  grows logarithmically.
2. **Space complexity:** This represents the amount of memory or storage required by the algorithm. Like time complexity, space complexity is also expressed using Big O notation. For example, an algorithm with space complexity  $O(n)$  uses memory proportional to the input size.

## CHAPTER -3

### Greedy Method

R. Banumathi

(Assistant Professor, Department of Computer science, Ponnaiah Ramajayam Institute of Science and Technology[PRIST], Thanjavur.)

#### Introduction

Greedy algorithms are a category of algorithms that solve optimization problems by making a series of choices that are locally optimal, aiming for a globally optimal solution. These algorithms operate by always choosing the best immediate option, without taking future outcomes into account.

#### Challenges of the Greedy Algorithm

Greedy algorithms are simple to implement and efficient, making them ideal for solving problems where finding the optimal solution is not necessary. They are often used in scenarios where a quick, satisfactory solution is more important than an optimal one. However, greedy algorithms can be challenging to design and validate, as ensuring their correctness can be complex. Despite these challenges, greedy algorithms are widely used in various applications, such as scheduling, data compression, and network routing.

#### **Benefits:**

##### Simplicity:

Developing greedy algorithms is typically straightforward.

##### Ease of Analysis:

Analyzing their runtime is often simpler than methods like divide and conquer, which involve complex recursion and numerous sub problems.

#### **Challenges:**

##### Correctness:

Verifying the correctness of greedy algorithms can be complex and requires deep understanding and inventive thinking. Proving their validity is often more intricate than their initial design.



## CHAPTER -4

"Dynamic Programming and Optimization Strategies:  
Solving Multistage Problems, Shortest Paths, and Combinatorial Challenges"

R. Idayathulla

(Assistant Professor, Department of Computer science, Ponnaiah Ramajayam  
Institute of Science and Technology[PRIST], Thanjavur.)

This study proposes an efficient deviation path algorithm for finding exactly  $k$  shortest simple paths without loops in road networks. The algorithm formulates the deviation path calculation process as repeated one-to-one searches for the shortest path in a dynamic network, where only a node and a link are restored at each search. Using this formulation, the proposed algorithm maintains and updates a single shortest path tree rooted at the destination. A re-optimization technique, lifelong planning  $A^*$ , is incorporated into the algorithm to efficiently calculate each deviation path by reusing the shortest path tree generated at the previous search. To verify the efficiency of the proposed algorithm, computational experiments were conducted using several real road networks, and the results showed that the proposed algorithm performed significantly better than state-of-the-art algorithms.

$K$  shortest path (KSP) problems involve finding the shortest path, the second shortest path, and so on to the  $k$ th shortest path between a given origin and a destination (O–D) pair.

For example, KSPs are usually provided in route guidance systems to satisfy various preferences that different users have for path choices. In addition, KSPs are often generated for approximating complicated network optimization problems with multiple objectives and/or constraints (Pugliese and Recently, KSPs are also utilized for transport big data mining and complex network analysis.

Therefore, it is necessary to develop efficient algorithms for finding KSPs in real large-scale transport networks.

In light of work in the literature, the KSP problems can be classified into two variants:  $k$  shortest simple path problems, and  $k$  shortest non-simple path problems. In the first variant, the paths are restricted to being simple and without loops, i.e., no node can be repeated. Paths in the second variant can be non-simple paths with loops. Compared with the non-simple path variant, the simple path variant is more frequently applicable to empirical scenarios (e.g. route guidance systems), and is significantly more challenging due to the additional “loopless” constraint. This study focuses on the simple path variant.

## CHAPTER 5

### Exploring Backtracking and Branch-and-Bound:

(Solutions to N-Queens, Subset Sums, Graph Coloring, and the Traveling Salesperson Problem)

M. Aarthi

(Assistant Professor, Department of Computer science, Ponnaiah Ramajayam  
Institute of Science and Technology[PRIST], Thanjavur.)

Branch-and-bound Algorithm Design is a technique in computer science that systematically enumerates candidate solutions, branches out choices into a solution space, sets bound on solution quality, and prunes poor solutions to effectively reduce the search space, especially for NP-complete problems.

Branch-and-bound

Branch-and-bound is a general technique for improving the searching process by systematically enumerating all candidate solutions and disposing of obviously impossible solutions.

Branch-and-bound usually applies to those problems that have finite solutions, in which the solutions can be represented as a sequence of options. The first part of branch-and-bound, branching, requires several choices to be made so that the choices branch out into the solution space.

Branching out to all possible choices guarantees that no potential solutions will be left uncovered. But because the target problem is usually NP-complete or even NP-hard, the solution space is often too vast to traverse. The branch-and-bound algorithm handles this problem by bounding and pruning. Bounding refers to setting a bound on the solution quality (e.g., the route length for TSP), and pruning means trimming off branches in the solution tree whose solution quality is estimated to be poor. Bounding and pruning are the essential concepts of the branch-and-bound technique, because they are used to effectively reduce the search space.

Branch-and-bound mainly addresses optimization problems, because bounding is often based on numerical comparisons. TSP that uses the route length as the bound is a classical application; however, it can also be applied to some decision problems.

## CHAPTER- 6

### Algorithm Design Techniques

P. Karthik

(Assistant Professor, Department of Computer science, Ponnaiah Ramajayam  
Institute of Science and Technology[PRIST], Thanjavur.)

#### **Algorithm Design Techniques**

Algorithm design techniques are systematic approaches used to create algorithms that efficiently solve specific computational problems. These techniques provide a structured framework for algorithm development, guiding programmers in devising solutions that are not only correct but also optimized for performance, scalability, and resource utilization.

or, Algorithm design techniques refer to the methods and strategies used to develop efficient and effective algorithms for solving computational problems. These techniques help algorithm designers create algorithms that are correct, optimal, and scalable.

#### **Common Algorithm Design Techniques:**

Brute Force:

The brute force technique involves trying out all possible solutions to a problem and selecting the one that works. While not the most efficient approach, it's often used as a baseline for comparison with more sophisticated algorithms.

Divide and Conquer:

This technique involves breaking down a problem into smaller, more manageable sub problems, solving each independently, and then combining their solutions to solve the original problem.

Dynamic Programming:

Dynamic programming is an optimization technique used to solve problems by breaking them down into simpler sub problems and solving each sub problem only once. The solutions to sub problems are stored in a table to avoid redundant computations. This technique is particularly useful for problems with overlapping sub problems, such as the knapsack problem and Fibonacci sequence calculation.

Greedy Algorithms:

Greedy algorithms make locally optimal choices at each step with the hope of finding a global optimum. These algorithms are often simple and intuitive but may not always produce the best solution.

## CHAPTER- 7

### Dynamic Strategies

G. Gayathri

(Assistant Professor, Department of Computer science, Ponnaiah Ramajayam  
Institute of Science and Technology[PRIST], Thanjavur.)

Dynamic memory management has been an important topic in computer systems for over three decades. High-performance algorithms for dynamic memory allocation and deallocation are of considerable interest. The primary goals of these algorithms are to speed up the dynamic memory allocation and deallocation as well as minimize internal and external fragmentation

One of the most commonly used allocation/deallocation techniques is First Fit. In brief, a list is maintained of free space and another list is maintained of allocated space. When an allocation request is made, the free list is searched until a free memory block is found that is at least as big as the request. Both lists are then updated accordingly. The algorithm's name comes from the fact that the very First Fit (i.e., block that is large enough) is returned. Deallocation is usually handled in a similar manner. The allocated list is searched until the specific block to be freed is found. Then, that block is removed from the allocated list, and the free list is updated accordingly. When a block of memory is freed, the algorithm examines the blocks before and after it to determine if they are also free. It coalesces the newly freed block with these blocks if possible and the freed block is linked into the free-list data structure. Obviously, an address-ordered free list can facilitate the deallocation process.

To reduce the search time to traverse through two lists, an efficient data structure that links two lists, called the Common List method, is presented. Its performance compared to a simple linked list implementation of the same First Fit algorithm is also described.

Next Fit is a variant of First Fit that searches from the position of the last search instead of starting from the beginning of memory as First Fit does, and is easily implemented with linked lists. Best Fit and Worst Fit search all of memory for an available space of memory which is closest and farthest from the requested size, respectively. Since these two algorithms search all available free spaces they often use more complex data structures such as balanced binary trees to organize the free memory areas, but it is convenient to still keep track of the allocated areas of memory via a linked list. If the allocated memory is maintained with a linked list, it is possible to use the Common List methodology to integrate this list with the free list data structure whether that structure is a linked list, binary tree, etc.

## CHAPTER- 8

### Master Theorem

R. Rajayogeswari

(Assistant Professor, Department of Computer science, Ponnaiah Ramajayam  
Institute of Science and Technology[PRIST], Thanjavur.)

Master Theorem provides a direct route to deduce the time complexity of algorithms that follow the divide-and-conquer paradigm. By applying this theorem, developers and computer science students can predict how an algorithm's performance scales with the size of the input. This capability is crucial in choosing the most efficient algorithm for a given problem, a frequent task in coding and software development, especially in learning platforms like codedamn where efficiency and optimization are often key learning outcomes.

#### **Background Information**

To fully grasp the Master Theorem, a foundational understanding of certain concepts in algorithm analysis is necessary. This includes familiarity with time complexity, Big O notation, and the divide-and-conquer approach.

#### **Basics of Algorithm Analysis**

Algorithm analysis revolves around evaluating the efficiency of an algorithm, primarily in terms of time and space complexity. Time complexity, often expressed using Big O notation, gives an upper bound on the time an algorithm takes relative to its input size. This concept is fundamental in understanding how algorithms scale and is a cornerstone in optimizing code, a skill highly emphasized in platforms like codedamn.

#### **Divide-and-Conquer Algorithms**

Divide-and-conquer algorithms work by breaking down a problem into smaller, more manageable sub-problems, solving each of these sub-problems, and then combining their solutions to solve the original problem. Classic examples include Merge Sort and Quick Sort. These algorithms are prevalent in computer science and form the basis of many complex data processing and analysis tasks.

## CHAPTER- 9

### String Algorithms

P. Sakila

(Assistant Professor, Department of Computer science, Ponnaiah Ramajayam  
Institute of Science and Technology[PRIST], Thanjavur.)

Algorithms, which are used for searching a string within another string. Use cases vary from Natural Language Processing to Plagiarism Detection, Search Engines, and Database Schemas. For instance, have you ever mistyped a word and searched for it? And have you seen Google's 'Did you mean ...' message? That's it. Another beautiful example is a search for text within the website, pdf file, or document.

The purpose of the string matching algorithms is to find an exact one or several occurrences of a given string (pattern/needle) in a larger string (sequence/haystack) or a text.

There's few algorithms mentioned here:

#### 1. Naïve Algorithm

A brute force approach, which checks all characters of the sequence.

It slides the haystack one by one to see the occurrence. If there's one found, it slides again to the following occurrences.

So, searching for a string with a brute approach will result in the time complexity of  $O(n*m)$  and in  $O(m*(n-m+1))$  in the worst case, where  $m$  is the length of the pattern/needle and the  $n$  is the length of the sequence/haystack.

#### 2. Knuth–Morris–Pratt algorithm (KMP)

This is an improved version of the Naive Algorithm for the haystack with a needle appearing more than once in it.

The algorithm does not traverse the haystack one by one, instead, when a mismatch is found, the KMP starts to seek a match from the character where the match was found.

#### 3. Boyer Moore Algorithm:

This is a Naive and KMP algorithms combo.

It preprocesses the string as KMP and uses it to skip the mismatches. One important point is that it starts matching from the last character of the needle.

## CHAPTER- 10

### Medians of Median Algorithm

P. Karthikeyan

(Assistant Professor, Department of Computer science, Ponnaiah Ramajayam  
Institute of Science and Technology[PRIST], Thanjavur.)

The median of medians is an approximate median selection algorithm, frequently used to supply a good pivot for an exact selection algorithm, most commonly quickselect, that selects the  $k$ th smallest element of an initially unsorted array. Median of medians finds an approximate median in linear time. Using this approximate median as an improved pivot, the worst-case complexity of quickselect reduces from quadratic to linear, which is also the asymptotically optimal worst-case complexity of any selection algorithm. In other words, the median of medians is an approximate median-selection algorithm that helps building an asymptotically optimal, exact general selection algorithm (especially in the sense of worst-case complexity), by producing good pivot elements.

Although this approach optimizes the asymptotic worst-case complexity quite well, it is typically outperformed in practice by instead choosing random pivots for its average complexity for sorting, without any overhead of computing the pivot.

Similarly, Median of medians is used in the hybrid introselect algorithm as a fallback for pivot selection at each iteration until  $k$ th smallest is found. This again ensures a worst-case linear performance, in addition to average-case linear performance: introselect starts with quickselect (with random pivot, default), to obtain good average performance, and then falls back to modified quickselect with pivot obtained from median of medians if the progress is too slow. Even though asymptotically similar, such a hybrid algorithm will have a lower complexity than a straightforward introselect up to a constant factor (both in average-case and worst-case), at any finite length.

If one instead consistently chooses "good" pivots, this is avoided and one always gets linear performance even in the worst case. A "good" pivot is one for which we can establish that a constant proportion of elements fall both below and above it, as then the search set decreases at least by a constant proportion at each step, hence exponentially quickly, and the overall time remains linear. The median is a good pivot – the best for sorting, and the best overall choice for selection – decreasing the search set by half at each step. Thus if one can compute the median in linear time, this only adds linear time to each step, and thus the overall complexity of the algorithm remains linear.

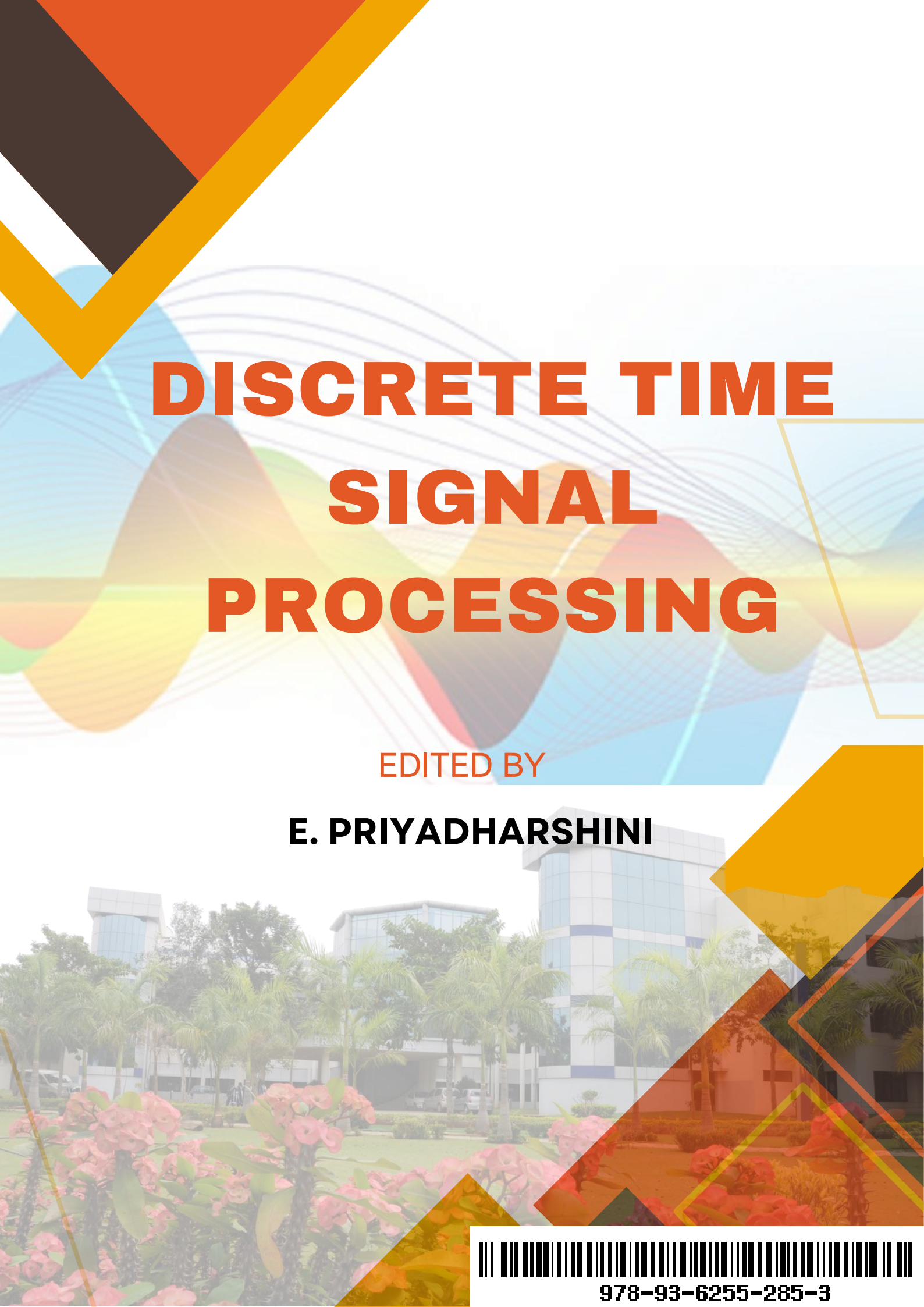

# **DISCRETE TIME SIGNAL PROCESSING**

EDITED BY

**E. PRIYADHARSHINI**



978-93-6255-285-3



DISCRETE-TIME SIGNAL PROCESSING

COPYRIGHT @ 2018 BY E.PRIYADHARSHINI

ALL RIGHTS RESERVED. NO PART OF THIS BOOK MAY BE REPRODUCED OR TRANSMITTED IN ANY FORM OR BY ANY MEANS WITHOUT WRITTEN PERMISSION FROM THE AUTHOR.

ISBN: 978-93-6255-285-3

PUBLISHER: Ponnaiyah Ramajayam Institute of Science and Technology (PRIST)

# TABLE OF CONTENTS

<b>CHAPTER</b>	<b>CONTENT</b>	<b>PAGE</b>
	<b>INTRODUCTION</b>	5
1	<b>INTRODUCTION TO DISCRETE-TIME SIGNALS AND SYSTEMS</b> Dr. SMITHA ELSA PETER	13
2	<b>SINUSOIDS, SPECTRUM REPRESENTATION</b> Dr. N. PARVATHAM	28
3	<b>SAMPLING</b> S. MAHESHWARAN	49
4	<b>ALIASING</b> R.SAVITHA	64
5	<b>FINITE IMPULSE RESPONSE (FIR) FILTER</b> P.GEETHA	85
6	<b>SIGNAL PROPERTIES</b> S.LILLYPET	96
7	<b>PROPERTIES OF FIR FILTERS</b> A.AMUDHA	107
8	<b>APPLICATION TO ANALYSIS AND DESIGN OF FIR FILTERS</b> R.SAVITHA	132
9	<b>EXAMPLES OF FIR FILTER DESIGN</b> S.SARASWATHY	168
10	<b>ADVANCED OF DISCRETE-TIME SIGNALS AND SYSTEMS</b> E.PRIYADHARSHINI	185
	<b>REFERENCES</b>	205

# CHAPTER 1 INTRODUCTION TO DISCRETE-TIME SIGNALS AND SYSTEMS

**Dr. SMITHA ELSA PETER**

*Professor, Department of ECE*

*Ponnaiyah Ramajayam Institute of Science and Technology, Tamil Nadu, India.*

Discrete-time signals are a fundamental concept in digital signal processing (DSP) and digital communications. They are used to represent data that varies in discrete intervals of time, as opposed to continuous-time signals, which vary continuously over time. Here's a comprehensive introduction to discrete-time signals, covering their definition, characteristics, types, and applications:

## \*\*1. Definition of Discrete-Time Signals

- **Description:** Discrete-time signals are sequences of values or samples taken at discrete intervals. They represent data points or signal values at specific time instances.
- **Notation:** A discrete-time signal is usually denoted as  $x[n]$ , where  $n$  is an integer representing the discrete time index.

## \*\*2. Characteristics of Discrete-Time Signals

### \*\*2.1. Time Domain Representation

- **Description:** The time domain representation shows how the signal values change over discrete time indices. This representation helps in analyzing and processing signals in terms of their time evolution.

### \*\*2.2. Amplitude

- **Description:** The amplitude of a discrete-time signal is the value of the signal at a particular time index. It can be real or complex depending on the nature of the signal.

### \*\*2.3. Periodicity

- **Description:** A discrete-time signal is periodic if it repeats itself after a certain number of samples. The period  $N$  of a periodic signal satisfies:

$$x[n] = x[n+N] \quad x[n] = x[n + N] = x[n+N]$$

- **Types:**
  - **Discrete-Time Periodic Signals:** Signals that repeat at regular intervals.
  - **Aperiodic Signals:** Signals that do not repeat.

## CHAPTER 2 SINUSOIDS, SPECTRUM REPRESENTATION

**Dr. N. PARVATHAM**

*Associate Professor, Department of ECE*

*Ponnaiyah Ramajayam Institute of Science and Technology, Tamil Nadu, India.*

Sinusoids are fundamental components of signals and systems in both analog and digital signal processing. They play a crucial role in understanding and analyzing various types of signals, especially when it comes to frequency analysis. Here's an in-depth look at sinusoids and their spectrum representation:

### \*\*1. Sinusoids

Description: A sinusoid is a smooth, periodic oscillation that can be described by either a sine or cosine function. It represents a continuous waveform with a single frequency.

Mathematical Representation:

Sine Function:

### \*\*1.2. Characteristics

Amplitude (A): The peak value of the sinusoid. It determines how strong or intense the signal is.

Frequency (f): The number of oscillations or cycles per second. It determines how fast the sinusoid oscillates.

Phase ( $\phi$ ): The horizontal shift of the sinusoid. It indicates how the wave is shifted relative to a reference.

Period (T): The time it takes for one complete cycle of the sinusoid. It is the reciprocal of frequency:

### \*\*2. Spectrum Representation

#### \*\*2.1. Frequency Domain Representation

Description: The frequency domain representation of a sinusoid shows how the signal's energy is distributed across different frequencies. This is achieved through Fourier Transform or its discrete counterpart, the Discrete Fourier Transform (DFT).

Fourier Transform (Continuous-Time):

#### \*2.2. Magnitude and Phase Spectrum

Magnitude Spectrum:

Description: Represents the amplitude of each frequency component. For a pure sinusoid, the magnitude spectrum will show peaks at the sinusoid's frequency

Phase Spectrum:

Description: Represents the phase shift of each frequency component. For a pure sinusoid, the phase spectrum will show a constant phase shift and a phase shift depending on the cosine function.

## CHAPTER 3 SAMPLING AND ALIASING

S. MAHESHWARAN

*Assistant Professor, Department of ECE*

*Ponnaiyah Ramajayam Institute of Science and Technology, Tamil Nadu, India.*

Sampling and aliasing are fundamental concepts in digital signal processing that deal with converting continuous signals into discrete signals and the potential issues that arise during this conversion. Here's a comprehensive overview:

### \*\*1. Sampling

#### \*\*1.1. Definition

- Description: Sampling is the process of converting a continuous-time signal into a discrete-time signal by taking periodic samples of the continuous signal.
- Goal: To create a sequence of values from a continuous signal that can be processed digitally.

#### \*\*1.2. Sampling Theorem (Nyquist-Shannon Theorem)

- Description: The theorem states that a continuous-time signal can be completely represented by its samples and reconstructed without loss of information if it is sampled at a rate greater than twice its highest frequency component.
- Formula:  $f_s \geq 2 \cdot f_{\max}$  Where:
  - $f_s$  = Sampling rate (samples per second or Hertz)
  - $f_{\max}$  = Maximum frequency of the signal (highest frequency component)

#### \*\*1.3. Sampling Process

- Procedure:
  1. Choose Sampling Rate: Determine the sampling rate  $f_s$  based on the highest frequency component of the signal.
  2. Take Samples: Periodically sample the continuous signal at intervals  $T_s = \frac{1}{f_s}$ , where  $T_s$  is the sampling period.
  3. Digitize Samples: Convert the sampled values into digital form for processing.
- Example: If a continuous-time signal  $x(t)$  with a maximum frequency of 1 kHz is sampled at 2.5 kHz, the discrete-time signal  $x[n]$  is obtained by sampling  $x(t)$  at intervals of 0.4 milliseconds.

## CHAPTER 4 ALIASING

R.SAVITHA

*Assistant Professor, Department of ECE*

*Ponnaiyah Ramajayam Institute of Science and Technology, Tamil Nadu, India.*

### 1. Aliasing

Definition

Description: Aliasing is an effect that occurs when a continuous-time signal is sampled at a rate that is insufficient to capture its highest frequency components. It results in different signals becoming indistinguishable or "aliased" when sampled. Consequences: Aliased signals can lead to distortion and inaccuracies in the reconstructed signal.

### 2. Frequency Folding

Description: Frequencies higher than half the sampling rate ( $f_s/2$ ) get mapped or "folded" back into the lower frequency range, causing them to overlap and be misinterpreted.

Formula: If a signal contains a frequency component  $f > f_s/2$

### 3. Aliasing Example

Description: If a signal with a frequency of 3 kHz is sampled at 4 kHz, which is less than twice the signal's frequency, the sampled signal will incorrectly represent the 3 kHz component as a lower frequency, due to aliasing.

Visual: A sine wave at 3 kHz sampled at 4 kHz will appear as a lower frequency sine wave because the sampling rate is not high enough to capture the original frequency accurately.

#### 3. Preventing Aliasing

##### 3.1. Anti-Aliasing Filter

Description: An anti-aliasing filter is used to remove high-frequency components from the continuous signal before sampling. This ensures that only frequencies below  $f_s/2$  are present in the signal.

Type: Typically a low-pass filter with a cutoff frequency at or below  $f_s/2$ .

##### 3.2. Proper Sampling Rate

Description: Choose a sampling rate that is at least twice the highest frequency component of the signal to avoid aliasing.

Example: For a signal with a maximum frequency of 1 kHz, sample at least at 2 kHz to avoid aliasing. For better accuracy, a higher sampling rate (e.g., 4 kHz) is often used.

## CHAPTER 5 FINITE IMPULSE RESPONSE (FIR) FILTER

### P.GEETHA

*Assistant Professor, Department of ECE  
Ponnaiyah Ramajayam Institute of Science and Technology, Tamil Nadu, India.*

Finite Impulse Response (FIR) filters are a class of digital filters widely used in signal processing. They are characterized by having a finite number of non-zero coefficients, which makes them particularly useful for various applications including audio processing, image processing, and communications.

Here's an in-depth look at FIR filters:

#### \*\*1. Definition and Structure

##### \*\*1.1. Definition

Description: An FIR filter is a type of digital filter whose impulse response is of finite duration. This means that the filter's response to an impulse input (a signal with a single non-zero value at time zero) will eventually settle to zero after a finite number of steps.

Impulse Response: The impulse response

$h[n]$  of an FIR filter is non-zero for only a finite number of samples and zero otherwise.

#### . Design of FIR Filters

##### \*\*2.1. Filter Types

Low-Pass FIR Filter: Allows frequencies below a certain cutoff frequency to pass through while attenuating frequencies above it.

High-Pass FIR Filter: Allows frequencies above a certain cutoff frequency to pass through while attenuating frequencies below it.

Band-Pass FIR Filter: Allows frequencies within a certain range to pass through while attenuating frequencies outside this range.

Band-Stop FIR Filter: Attenuates frequencies within a certain range while allowing frequencies outside this range to pass through.

## CHAPTER 6 SIGNAL PROPERTIES

S.LILLYPET

*Associate Professor, Department of ECE*

*Ponnaiyah Ramajayam Institute of Science and Technology, Tamil Nadu, India*

- Understanding signal properties is crucial for analyzing and processing signals effectively in various applications, including communications, audio processing, image processing, and control systems.
- Basic Signal Properties
  - \*\*1.1. Amplitude
  - Definition: The amplitude of a signal refers to its maximum value or strength. It represents the signal's magnitude at any given time.
  - 1.2. Frequency
  - Definition: Frequency is the number of oscillations or cycles that a signal completes in one second.
  - Period
  - Definition: The period of a signal is the duration of one complete cycle of the signal.
  - Phase

Definition: The phase of a signal refers to the position of the waveform relative to a reference point in time.

Definition: The waveform of a signal represents its shape over time.

### **\*\*2. Signal Classification**

#### **\*\*2.1. Continuous-Time Signals**

Definition: Signals that are defined at every instant of time.

Example: Analog audio signals, natural sound waves.

#### **\*\*2.2. Discrete-Time Signals**

Definition: Signals that are defined only at discrete intervals of time.

Example: Digital audio signals, sampled data from sensors.

#### **\*\*2.3. Analog Signals**

Definition: Continuous signals that vary smoothly over time and can take any value within a range.



## CHAPTER 7 PROPERTIES OF FIR FILTERS

### A. AMUDHA

*Assistant Professor, Department of ECE  
Ponnaiyah Ramajayam Institute of Science and Technology, Tamil Nadu, India.*

The properties of discrete-time signals (often abbreviated as *dd*-properties) play a crucial role in the analysis and design of Finite Impulse Response (FIR) filters. Understanding these properties helps in designing FIR filters that meet specific requirements and perform efficiently in practical applications. Here's a detailed look at these properties and their application in the analysis and design of FIR filters:

#### \*\*1. Properties of Discrete-Time Signals

##### \*\*1.1. Linearity

**Definition:** A discrete-time system or filter is linear if it satisfies the principle of superposition. This means that if the system is linear, the response to a weighted sum of inputs is the weighted sum of the responses to each input.

**Application to FIR Filters:** FIR filters are inherently linear systems. The linearity property ensures that if you apply a linear combination of signals to an FIR filter, the output will be a corresponding linear combination of the filter's responses to those individual signals.

##### \*\*1.2. Time Invariance

**Definition:** A system is time-invariant if a shift in the input signal results in an identical shift in the output signal.

**Application to FIR Filters:** FIR filters are time-invariant systems. If the input signal is shifted in time, the output signal will be shifted by the same amount. This property simplifies the analysis of FIR filters and ensures predictable behavior.

##### \*\*1.3. Causality

**Definition:** A system is causal if its output at any time depends only on the current and past input values, not on future values.

##### \*1.4. Stability

**Definition:** A system is stable if bounded inputs always produce bounded outputs.

##### \*1.5. Frequency Response

**Definition:** The frequency response of a discrete-time signal or system describes how the signal's amplitude and phase are altered by the system as a function of frequency.

## CHAPTER 8 APPLICATION TO ANALYSIS AND DESIGN OF FIR FILTERS

R.SAVITHA

*Assistant Professor, Department of ECE*

*Ponnaiyah Ramajayam Institute of Science and Technology, Tamil Nadu, India.*

### Design Specifications

**Frequency Response Specifications:** To design an FIR filter, you first specify the desired frequency response (magnitude and phase) that meets the filtering requirements. This involves setting parameters such as cutoff frequencies, passband ripple, and stopband attenuation.

**Application:** FIR filters are designed using various methods such as the windowing method, frequency sampling method, or optimal design algorithms. The chosen design method will produce filter coefficients

$h[n]$  that provide the desired frequency response.

### \*\*2.2. Impulse Response and Filter Coefficients

**Impulse Response:** The impulse response

$h[n]$  of an FIR filter is finite in duration and directly determines the filter's characteristics.

**Filter Coefficients:** The coefficients

$h[n]$  are the values used in the convolution operation to produce the output signal. The choice of these coefficients affects the filter's behavior, including its frequency response and phase characteristics.

### \*\*2.3. Windowing Method

**Method Overview:** The windowing method involves designing an ideal filter and then applying a window function to truncate the ideal impulse response.

**Steps:**

**Determine Ideal Response:** Define the ideal impulse response based on the desired frequency response.

**Apply Window Function:** Multiply the ideal response by a window function to obtain a finite-length impulse response.

**Application:** The choice of window function (e.g., Hamming, Hanning, Blackman) affects the trade-off between main lobe width and side lobe level in the frequency response.

### \*\*2.4. Frequency Sampling Method

**Method Overview:** This method involves specifying the desired frequency response and deriving the filter .

## CHAPTER 9 EXAMPLES OF FIR FILTER DESIGN

**S.SARASWATHY**

*Assistant Professor, Department of ECE*

*Ponnaiyah Ramajayam Institute of Science and Technology, Tamil Nadu, India.*

### **Low-Pass FIR Filter Design**

Specification: Design a low-pass FIR filter with a cutoff frequency of 1 kHz and a sampling rate of 8 kHz.

Design Steps: Use the windowing method or optimal design methods to determine the filter coefficients that will provide the desired cutoff frequency and stopband attenuation.

### **Band-Pass FIR Filter Design**

Specification: Design a band-pass FIR filter with passband frequencies of 1 kHz and 3 kHz.

Design Steps: Specify the passband and stopband frequencies, choose a design method, and calculate the filter coefficients to achieve the desired band-pass characteristics.

Design Method: Optimal Design (Parks-McClellan)

Design Method: Frequency Sampling

Specify Desired Frequency Response:

Magnitude Response: Design a filter that passes frequencies between 500 Hz and 1 kHz and attenuates other frequencies.

Sample Frequency Response:

Frequency Sampling: Sample the desired frequency response at discrete frequencies and compute the inverse Fourier transform to get the impulse response.

Calculate Filter Coefficients:

Implementation: Using MATLAB or Python, compute the FIR filter coefficients.

Verify Filter Response:

Frequency Response: Ensure the filter meets the passband and stopband specifications.

## CHAPTER 10 ADVANCED OF DISCRETE-TIME SIGNALS AND SYSTEMS

**E.PRIYADHARSHINI**

*Assistant Professor, Department of ECE*

*Ponnaiyah Ramajayam Institute of Science and Technology, Tamil Nadu, India.*

Advanced concepts in discrete-time signals and systems build upon fundamental principles to address more complex and sophisticated signal processing and system analysis tasks. Here's an overview of some advanced topics in discrete-time signals and systems, including their applications and implications.

### **\*\*1. Advanced Signal Properties**

#### **\*\*1.1. Z-Transform**

1. **Definition:** The Z-transform is a powerful tool for analyzing discrete-time signals and systems, particularly in the z-domain.
2. **Definition:**
3. **Applications:**
  - **System Analysis:** Simplifies the analysis of linear time-invariant (LTI) systems by converting convolution into multiplication.
  - **Filter Design:** Used in digital filter design and implementation.

#### **. Discrete Fourier Transform (DFT) and Fast Fourier Transform (FFT)**

- **DFT:**
  - **Definition:** The DFT converts a discrete-time signal from the time domain to the frequency domain.
  - **Applications:** Analyzes the frequency components of a discrete signal.
- **FFT:**
  - **Definition:** An efficient algorithm for computing the DFT.
  - **Applications:** Speeds up the computation of the DFT, essential for real-time signal processing.

#### **\*\*1.3. Multi-Rate Signal Processing**

- **Definition:** Involves changing the sampling rate of signals through processes like decimation (downsampling) and interpolation (upsampling).

#### **\*\*1.4. Adaptive Filters**

- **Definition:** Filters that adjust their coefficients based on the input signal and desired response.



# COMMUNICATION NETWORKS

EDITED BY  
**A.AARTHI**



978-93-6255-734-6

COMMUNICATION NETWORKS Copyright @ 2018 by *Mrs. A.AARTHI*

All rights reserved. No part of this book may be reproduced or transmitted in any form or by any means without written permission from the author.

ISBN: 978-93-6255-734-6

Publisher: PUBLICATIONS

# TABLE OF CONTENTS

<b>CHAPTER</b>	<b>CONTENT</b>	<b>PAGE</b>
	<b>INTRODUCTION</b>	5
1	<b>NETWORK TOPOLOGIES</b> R.SAVITHA	13
2	<b>PROTOCOLS AND STANDARDS</b> A.AMUDHA	28
3	<b>NETWORK SECURITY</b> S.SARASWATHY	49
4	<b>NETWORK MANAGEMENT</b> P.GEETHA	64
5	<b>EMERGING TECHNOLOGIES</b> S. MAHESHWARAN	85
	<b>REFERENCES</b>	100

## CHAPTER 1 NETWORK TOPOLOGIES

**R.SAVITHA**

*Assistant Professor, Department of ECE*

*Ponnaiyah Ramajayam Institute of Science and Technology, Tamil Nadu, India.*

Network topologies refer to the physical or logical arrangement of network devices and how they are interconnected. Each topology has its own characteristics in terms of performance, reliability, and scalability. Here are the most common types of network topologies:

### 1. Bus Topology

Structure: All devices are connected to a single central cable (called the bus).

### 2. Star Topology

Structure: All devices are connected to a central hub, switch, or router.

Use Case: Most modern networks (LANs), including home and office networks.

### 3. Ring Topology

Structure: Devices are connected in a circular fashion, and each device has exactly two neighbors.

Use Case: Some legacy networks, but not widely used today.

### 4. Mesh Topology

Structure: Each device is connected to every other device in the network.

Use Case: WANs (like the internet backbone), military or critical systems requiring high reliability.

### 5. Tree Topology

Structure: A combination of star and bus topologies. Devices are connected in hierarchical levels, often starting with a central node and branching out.

Use Case: Large networks, like universities or enterprises, where scalability is needed.

### 6. Hybrid Topology

Structure: Combines two or more topologies, for example, star-bus or star-ring.

Use Case: Large, complex networks where a single topology isn't enough.



# CHAPTER 2 PROTOCOLS AND STANDARDS

## A.AMUDHA

*Assistant Professor, Department of ECE*

*Ponnaiyah Ramajayam Institute of Science and Technology, Tamil Nadu, India.*

A protocol is a set of rules that dictate how data is transmitted and received over a network. Different protocols manage different aspects of communication, such as how data is divided into packets, how devices are addressed, and how errors are handled. Here are some important protocols in networking:

### 1. Transmission Control Protocol/Internet Protocol (TCP/IP)

**Purpose:** The fundamental protocol suite for the internet and most networks. TCP handles reliable data transfer, while IP addresses and routes packets.

### 2. Hypertext Transfer Protocol (HTTP/HTTPS)

**Purpose:** Used for transferring web pages and web-based data between a web server and a client (browser).

**Use Case:** Web browsing and secure transactions online (e.g., online shopping, banking).

### 3. File Transfer Protocol (FTP)

**Purpose:** Used for transferring files between a client and a server.

**Use Case:** Uploading and downloading files from websites, managing servers.

### 4. Simple Mail Transfer Protocol (SMTP)

**Purpose:** Protocol for sending email messages.

**Use Case:** Sending emails through applications like Gmail, Outlook.

### 5. Internet Message Access Protocol (IMAP) and Post Office Protocol (POP3)

**Purpose:** Used for retrieving emails from mail servers.

**Use Case:** Email retrieval in clients like Thunderbird, Outlook.

### 6. Dynamic Host Configuration Protocol (DHCP)

**Purpose:** Automatically assigns IP addresses to devices on a network.

## CHAPTER 3 NETWORK SECURITY

**S.SARASWATHY**

*Assistant Professor, Department of ECE*

*Ponnaiyah Ramajayam Institute of Science and Technology, Tamil Nadu, India.*

Network security refers to the practices, tools, and policies designed to protect networks, devices, and data from unauthorized access, misuse, modification, or denial of service. It involves multiple layers of defense and security measures that safeguard both the infrastructure and the data traveling through the network.

Here are key concepts, techniques, and tools related to network security:

### 1. Types of Network Security Threats

**Malware:** Software designed to harm, exploit, or damage a network or its devices. Examples include viruses, worms, Trojans, ransomware, and spyware.

**Phishing:** Fraudulent attempts to obtain sensitive information by pretending to be a trustworthy source, often via email or malicious websites.

**Denial-of-Service (DoS) Attacks:** Attacks aimed at overwhelming a network or server to make it unavailable to users. A more severe variant is Distributed Denial-of-Service (DDoS), where the attack is launched from multiple devices.

**Insider Threats:** Threats posed by individuals within an organization who misuse their access to compromise network security.

### 2. Key Network Security Techniques and Measures

#### 1. Firewalls

**Purpose:** A firewall is a barrier that monitors and controls incoming and outgoing network traffic based on predefined security rules.

**Types:**

**Packet-Filtering Firewalls:** Inspect packets and allow or block them based on source and destination IP addresses, protocols, or ports.

**Stateful Firewalls:** Monitor the state of active connections and make decisions based on the context of the traffic (e.g., only allowing return traffic from legitimate requests).

**Next-Generation Firewalls (NGFW):** Include advanced features such as deep packet inspection, application-level filtering, and intrusion prevention. Use Case: Prototyping, IoT applications on microcontrollers like the ESP8266, and educational purposes.. 49

# CHAPTER 4 NETWORK MANAGEMENT

**P.GEETHA**

*Assistant Professor, Department of ECE  
Ponnaiyah Ramajayam Institute of Science and Technology, Tamil Nadu, India.*

Network management refers to the processes, tools, and protocols used to monitor, control, and maintain the performance, availability, and security of a network. Effective network management ensures that network resources operate efficiently and that issues are detected, diagnosed, and resolved quickly. This discipline includes several key areas such as performance management, fault detection, configuration management, and security.

## Key Areas of Network Management

### 1.1 Fault Management

**Purpose:** Detects, logs, and resolves network faults (problems) that can affect performance and availability.

**Key Components:**

**Fault Detection:** Monitoring devices and systems for issues (e.g., device failure, link disruption).

**Alarm Systems:** When a fault is detected, the system triggers alerts to notify network administrators.

**Troubleshooting Tools:** Tools that help diagnose and fix problems (e.g., using ping, traceroute, or specialized software like Nagios).

**Use Cases:**

Automatic alerts when a server goes down.

Resolving connectivity issues in real-time.

### 1.2 Performance Management

**Purpose:** Monitors and analyzes the performance of network resources to ensure efficient operation and troubleshoot bottlenecks.

**Metrics:**

**Bandwidth Utilization:** The amount of data being transferred over a link compared to its total capacity.

**Throughput:** The rate at which data is successfully transmitted through the network.

**Latency:** The time it takes for data to travel from source to destination.

**Packet Loss:** The percentage of packets lost during transmission.

## CHAPTER 5 EMERGING TECHNOLOGIES

S. MAHESHWARAN

*Assistant Professor, Department of ECE*

*Ponnaiyah Ramajayam Institute of Science and Technology, Tamil Nadu, India.*

Emerging technologies refer to new and innovative advancements in science and technology that have the potential to reshape industries, improve efficiencies, or even revolutionize how we live and work. These technologies often stem from cutting-edge research and offer transformative solutions to modern-day challenges. Below are some key emerging technologies that are gaining prominence across various sectors:

### 1. Artificial Intelligence (AI) and Machine Learning (ML)

Overview: AI refers to the simulation of human intelligence in machines, enabling them to perform tasks like problem-solving, decision-making, and learning from experience. Machine Learning is a subset of AI that focuses on training machines to learn from data and improve over time without being explicitly programmed.

Key Applications:

Natural Language Processing (NLP): Used in voice assistants (e.g., Siri, Alexa) to understand and process human language.

Computer Vision: Enabling machines to interpret visual data, such as facial recognition, autonomous vehicles, and medical imaging.

Predictive Analytics: Leveraged in industries like finance, healthcare, and retail for forecasting trends and making data-driven decisions.

Generative AI: Creating new content (text, images, music) using AI models like GPT, DALL-E, or GANs.

Challenges:

Ethical concerns, such as bias in AI algorithms, and the impact of AI on employment.

### 2. 5G Technology

Overview: 5G is the fifth generation of mobile network technology, designed to deliver ultra-fast internet speeds, low latency, and increased network capacity.

Key Applications:

Internet of Things (IoT): 5G enables seamless connectivity for billions of IoT devices, supporting smart cities, autonomous vehicles, and industrial automation.

Augmented Reality (AR) and Virtual Reality (VR): 5G will enhance immersive experiences by providing the necessary bandwidth and low latency for real-time interactions.

Healthcare: 5G supports telemedicine, remote surgeries, and enhanced medical diagnostics.

Challenges:

Infrastructure costs and rollout delays in certain regions, and concerns about network security.

### 3. Internet of Things (IoT)

Overview: IoT refers to the network of interconnected physical devices embedded with sensors, software, and other technologies to collect and share data. These devices range from smart home gadgets to industrial sensors.

Key Applications:

Smart Homes: Devices like smart thermostats, security systems, and appliances communicate to enhance home automation.

Smart Cities: IoT helps manage urban infrastructure efficiently by optimizing traffic management, waste disposal, and energy use.

Industry 4.0: IoT is central to smart manufacturing, enabling predictive maintenance and automation in factories.

Challenges:

Data security and privacy concerns due to the vast amount of personal and sensitive information collected by IoT devices.

### 4. Blockchain and Distributed Ledger Technology (DLT)

Overview: Blockchain is a decentralized ledger technology that records transactions across multiple computers in a way that ensures security, transparency, and immutability. It is best known for powering cryptocurrencies like Bitcoin.

# COST ACCOUNTING

Edited by

**DR. D.SILAMBARASAN**



978-93-6255-933-3

Cost Accounting

Copyright © 2018 by Dr. D. Silambarasan

All rights reserved. No part of this book may be reproduced or transmitted in any form or by any means without written permission from the author.

ISBN: 978-93-6255-933-3

Publisher: Ponnaiyah Ramajayam Institute of Science and Technology (PRIST)

## TABLE OF CONTENTS

CHAPTER-I.....	1
Introduction to Cost Accounting	
Dr. R. Selvaraj	
CHAPTER-II.....	10
Classification of Cost.	
Dr. R. Selvaraj	
CHAPTER-III.....	15
Material Cost,Employee Costs	
Dr.S.Rajendran	
CHAPTER-IV.....	20
Direct Expenses,Overheads	
Dr.S.Rajendran	
CHAPTER-V.....	25
Job Costing	
Dr. G. Karthiga	
CHAPTER-VI.....	30
Batch Costing	
Dr. V. Sridevi	
CHAPTER-VII.....	35
Contract Costing	
Dr. V. Sridevi	
CHAPTER-VIII.....	40
Process Costing	
Dr. R. Rajavardhini	
CHAPTER-IX.....	45
Marginal Costing	
Dr. R. Rajavardhini	
CHAPTER-X.....	50
Standard Costing & Variance Analysis	
Dr. G. Karthiga	
REFERENCES.....	55



## CHAPTER –I INTRODUCTION TO COST ACCOUNTING

Dr. R. Selvaraj  
*Department of Commerce,*  
*Ponnaiyah Ramajayam Institute of Science & Technology(PRIST)*

Cost Accounting may be defined as “Accounting for costs classification and analysis of expenditure as will enable the total cost of any particular unit of production to be ascertained with reasonable degree of accuracy and at the same time to disclose exactly how such total cost is constituted”. Thus Cost Accounting is classifying, recording an appropriate allocation of expenditure for the determination of the costs of products or services, and for the presentation of suitably arranged data for the purpose of control and guidance of management.

Cost Accounting can be explained as follows: -

Cost Accounting is the process of accounting for cost which begins with recording of income and expenditure and ends with the preparation of statistical data.

It is the formal mechanism by means of which cost of products or services are ascertained and controlled.

Cost Accounting provides analysis and classification of expenditure as will enable the total cost of any particular unit of product / service to be ascertained with reasonable degree of accuracy and at the same time to disclose exactly how such total cost is constituted. For example, it is not sufficient to know that the cost of one pen is ` 25/- but the management is also interested to know the cost of *material* used, the amount of *labour* and *other expenses* incurred so as to control and reduce its cost.

It establishes budgets and standard costs and actual cost of operations, processes, departments or products and the analysis of variances, profitability and social use of funds.

Thus Cost Accounting is a quantitative method that collects, classifies, summarizes and interprets information for product costing, operation planning and control and decision making.

*Costing: Costing is defined as the technique and process of ascertaining costs.*

The technique in costing consists of the body of principles and rules for ascertaining the costs of products and services. The technique is dynamic and changes with the change of time. The process of costing is the day to day routine of ascertaining costs. It is popularly known as an arithmetic process. For example, If the cost of producing a product say ` 200/-, then we have to refer material, labour and expenses accounting and arrive the above cost as follows:

Material	100
Labour	40
Expenses	60
Total	200

Finding out the breakup of the total cost from the recorded data is a daily process. That is why it is called arithmetic process/daily routine. In this process we are classifying the recorded costs and summarizing at each element and total is called technique.

**Cost Accountancy:** Cost Accountancy is defined as ‘*the application of Costing and Cost Accounting principles, methods and techniques to the science, art and practice of cost control and the ascertainment of profitability*’. It includes the presentation of information derived there from for the purposes of managerial decision making. Thus, Cost Accountancy is the science, art and practice of a Cost Accountant.

## CHAPTER –II CLASSIFICATION OF COST

Dr. R. Selvaraj  
*Department of Commerce,*  
*Ponnaiyah Ramajayam Institute of Science & Technology(PRIST)*

Types of costing have been designed to suit the needs of individual business conditions. The basic principles underlying all these methods are the same i.e. to collect and analyze the expenditure according to the elements of costs and to determine the cost of each Cost Centre and or Cost Unit. Classification of cost is the arrangement of items of costs in logical groups having regard to their nature or purpose. Items should be classified by one characteristic for a specific purpose without ambiguity. Scheme of classification should be such that every item of cost can be classified. In view of the above, cost classification may be explained as below:

As per Cost Accounting Standard 1 (CAS-1), the basis for cost classification is as follows:

- (a) Nature of expense
- (b) Relation to Object – Traceability
- (c) Functions / Activities
- (d) Behaviour – Fixed, Semi-variable or Variable
- (e) Management decision making
- (f) Production Process
- (g) Time Period

Classification of cost is the process of grouping the components of cost under a common designation on the basis of similarities of nature, attributes or relations. It is the process of identification of each item and the systematic placement of like items together according to their common features.

### *Classification:*

Costs should be gathered together in their natural grouping such as Material, Labour and Other Direct expenses. Items of costs differ on the basis of their nature. The elements of cost can be classified in the following three categories. 1. Material 2. Labour 3. Expenses

**Material Cost:** Material cost is the cost of material of any nature used for the purpose of production of a product or a service. It includes cost of materials, freight inwards, taxes & duties, insurance ...etc. directly attributable to acquisition, but excluding the trade discounts, duty drawbacks and refunds on account of excise duty and vat.

**Labour Cost:** Labour cost means the payment made to the employees, permanent or temporary for their services. Labour cost includes salaries and wages paid to permanent employees, temporary employees and also to the employees of the contractor. Here salaries and wages include all the benefits like provident fund, gratuity, ESI, overtime, incentives...etc

**Expenses:** Expenses are other than material cost or labour cost which are involved in an activity.

## CHAPTER –III MATERIAL COST, EMPLOYEE COSTS

Dr.S.Rajendran

*Department of Commerce,*

*Ponnaiyah Ramajayam Institute of Science & Technology(PRIST)*

**MATERIAL COST:** Material is any substance (Physics term) that forms part of or composed of a finished product. i.e material refers to the commodities supplied to an undertaking for the purpose of consumption in the process of manufacturing or of rendering service or for transformation into products. The term ‘Stores’ is often used synonymously with materials, however, stores has a wider meaning and it covers not only raw materials consumed or utilized in production but also such other items as sundry supplies, maintenance stores, fabricated parts, components, tools, jigs, other items, consumables, lubricants.....etc. Finished and partly finished products are also often included under the term ‘Stores’. Materials are also known as Inventory. The term Materials / Inventory covers not only raw materials but also components, work-in-progress and finished goods and scrap also.

Material cost is the significant constituent of the total cost of any product. It constitutes 40% to 80% of the total cost. The percentages may differ from industry to industry. But for manufacturing sector the material costs are of greatest significance. Inventory also constitutes a vital element in the Working Capital. So it is treated as equivalent to cash. Therefore, the analysis and control on Material Cost is very important.

*Objectives of Material Control System:*

*Material Control: The function of ensuring that sufficient goods are retained in stock to meet all requirements without carrying unnecessarily large stocks.*

The objectives of a system of material control are as following: -

- (a) To make continuous availability of materials so that there may be uninterrupted flow of materials for production. Production may not be held up for want of materials.
- (b) To purchase requisite quantity of materials to avoid locking up of working capital and to minimize risk of surplus and obsolete stores.
- (c) To make purchase competitively and wisely at the most economical prices so that there may be reduction of material costs.
- (d) To purchase proper quality of materials to have minimum possible wastage of materials.
- (e) To serve as an information centre on the materials knowledge for prices, sources of supply, lead time, quality and specification.

**LABOUR COST:** Labour is an important element of cost and for overall cost control and cost reduction, Labour Cost is of paramount importance. Labour Cost is also called as Employee Cost. However, for control and reduction of Labour Cost, it is essential to compute the Labour Cost in a scientific manner and hence there should be proper systems and processes and documentation, which will help computation of Labour Cost in a scientific manner. It should be remembered that Labour is not like material as there is a human aspect involved in it. Therefore, there should be a comprehensive study of all related aspects of Labour Cost and then only computation and control over the same will be possible. Attention should also be paid to the productivity aspect. Low productivity results in higher Labour Cost per unit while higher productivity will reduce the Labour Cost per unit. All these aspects of Labour Cost are discussed in detail in this chapter.

*Labour Cost Accounting:*

There should be a proper cost accounting system, which will identify the Direct and Indirect Labour Cost. Similarly, the cost accounting department should be able to generate and maintain records for time keeping, time booking, idle and overtime, impact of incentive schemes, per unit of Labour, cost due to Labour Turnover and other relevant records.

Thus from the above mentioned points, it will be clear that there is a need to control the Labour Cost and it can be done by the combined efforts of various departments

## CHAPTER –IV DIRECT EXPENSES, OVERHEADS

Dr.S.Rajendran,  
*Department of Commerce,*  
*Ponnaiyah Ramajayam Institute of Science & Technology(PRIST)*

**Direct expenses:** Direct expense or chargeable expense is that which can be allocated to a cost center or cost unit and indirect expense is that which needs to be apportioned. There may be items of expense direct in relation to some cost center. Thus rent and rates, heating & lighting, depreciation & insurance are often allocated or charged directly to the appropriate service cost center, the totals of service department cost are however, apportioned to other cost centers before being absorbed by cost units as overheads. These costs are direct costs of the first cost center, but indirect costs of other production cost centers, as well as being indirect cost of cost units.

*Direct expenses as defined in CAS-10 (Limited Revision 2017), 'Expenses relating to manufacture of a product or rendering a service, which can be identified or linked with the cost object other than direct material cost and direct employee cost'.*

The more a factory is departmentalized, the greater will be the proportion of expenses which can be classified as direct. Thus cost of medicines, first aid, and other expenses in connection with the medical service are direct expenses of medical service department, but if there is no medical service department, the expenses would have been distributed to all the cost centers at the very beginning.

The following expenses may be treated as direct expenses: -

- (a) Cost of patents, royalty payment;
- (b) Hire charges in respect of special machinery or plant;
- (c) Cost of special patterns, cores, designs or tools;
- (d) Experimental costs and expenditure in connection with models and pilot schemes;
- (e) Architects, surveyors and other consultants fee;
- (f) Travelling expenses to sites;
- (g) Inward charges and freight charges on special material.

**Overheads:** An overhead is the amount which is not identified with any product. The name overhead might have come due to the reason of over and above the normal heads of expenditure. It is the aggregate of indirect material, indirect labour and indirect expenditure. The generic term used to denote indirect material, indirect labour and indirect expenses. Thus overheads form a class of cost that cannot be allocated or absorbed but can only be apportioned to cost units.

In earlier days, overheads were not given much importance, because the prime cost constitutes 50-80% of the total cost. However, with the modern trend towards the mechanization, automation, and mass production, overhead costs have grown considerably in size and in many undertakings the proportion of overhead costs to the total costs of products is appreciably high. High overheads do not indicate inefficiency if the increase in overheads is due to the following likely causes:

- (a) Improved methods of managerial control like Accountancy, Production Control, Work Study, Cost and Management Accountancy...etc. In the process of reducing costs of other elements, viz. direct material and direct labour, overhead costs are likely to increase.
- (b) Large scale production or mass production.
- (c) Use of costly machines and equipment's increases the amounts of depreciation, maintenance expenditure and similar other items of overhead costs.
- (d) Less human efforts are necessary with automatic machines. A major portion of the cost is allocated direct to machines, thus increasing the machine overhead costs.
- (e) Increased efficiency and productivity of labour has the effect of pushing up the overhead to direct labour ratio.

## CHAPTER –V JOB COSTING

Dr. G. Karthiga,  
*Department of Commerce,*  
*Ponnaiyah Ramajayam Institute of Science & Technology(PRIST)*

Industries which manufacture products or render services against specific orders as distinct from continuous production for stock or sales use the job costing or job order method of cost accounting. The method is also known under various other names, such as specific order costing, production order costing, job lot costing or lot costing. Every order in job costing is separate and it is not essential that the same manufacturing operations be carried out or the same materials be utilized in respect of each. However, a number of identical orders or identical products may be combined together to form lots or batches, each such lot or batch constituting a job order. In the job costing system, an order or a unit, lot, or batch of a product may be taken as a cost unit, i.e. a job.

In job costing, there is no averaging of costs except to the extent that in the ascertainment of unit cost, the cost of a lot of products in one order is obtained. A job or an order may extend to several accounting periods and job costs are, therefore, not related to particular periods.

Job cost accounting is followed in three types of manufacturing organizations:

- (i) Jobbing concerns.
- (ii) Small firms.
- (iii) Large enterprises manufacturing a variety of products.

### ***Procedure for Job Cost Accounting:***

On receipt of an order from the customer or an indication from the sales department for manufacturing a particular product, the production planning department prepares a suitable design for the product or job. It also works out the requirements of materials for the product and prepares a list of operations indicating the various operations to be carried out and their sequence, and the shops, departments, plants or machines to be entrusted with each of the operations.

A Production Order is issued giving instructions to the shops to proceed with the manufacture of the product. The production order constitutes the authority for work. Usually a production order contains all relevant information regarding production, such as detailed particulars of the job or product, the quantity or units to be manufactured, date of start of production, probable date of completion, details of materials required as per the bill of materials, the operations and the various shops involved in performing them and the route of the job should take.

The production order usually lays down only the quantities of materials required and the time allowed for the operations, but the values of materials and labour are also sometimes indicated. In the later case, the production order serves the combined purpose of an order for manufacture as well as the cost sheet on which the cost of the order is compiled.

The production order also provides for the material and labour on account of normal wastage or spoilage of the product in the final stage or during the various stages of manufacture.

*Production orders may, in general, be of three types:*

- (i) Assembly type of order.
- (ii) Sub-assembly type of order.
- (iii) Components or parts production type.



## CHAPTER –VI BATCH COSTING

Dr. V. Sridevi  
*Department of Commerce,*  
*Ponnaiyah Ramajayam Institute of Science & Technology(PRIST)*

### *Meaning*

Batch Costing is that form of specific order costing under which each batch is treated as a cost unit and costs are accumulated and ascertained separately for each batch. Each batch consists of a number of like units.

### *Basic Features*

- (a) Each batch is treated as a cost unit.
- (b) All costs are accumulated and ascertained for each batch.
- (c) A separate Batch Cost Sheet is used for each batch and is assigned a certain number by which the batch is identified.
- (d) The cost per unit is ascertained by dividing the total cost of a batch by the number of items produced in that batch.

### *Applications*

Batch Costing is applied in those industries where the similar articles are produced in definite batches for internal consumption in the production of finished products or for sale to customers generally. It is generally applied in –

- (a) Read made Garments Manufacturing Industries
- (b) Pharmaceutical/ Drug Industries
- (c) Spare parts and Components Manufacturing Industries
- (d) Toys Manufacturing Industries
- (e) Tyre and Tubes Manufacturing Industries.

### *Economic Batch Quantity (EBQ) Meaning*

Economic Batch Quantity refers to the optimum quantity batch which should be produced at a point of time so that the Set up & Processing Costs and Carrying Costs are together optimized.

### *Setting up & Processing Costs*

The setting up and processing costs refer to the costs incurred for setting up and processing operations before the start of production of a batch. There is an inverse relationship between batch size and setup & processing costs.

Large the Batch size : Lower the set up costs because of few batches

Smaller the Batch Size: Higher the set up costs because of more batches

### **Carrying Costs**

The carrying costs refer to the costs incurred in maintaining a given level of inventory. There is a positive relationship between batch size and carrying costs.

Large the Batch size : Higher the carrying costs because of high average inventory

Smaller the Batch Size: Lower the carrying costs because of low average inventory

**CHAPTER –VII CONTRACT COSTING**  
Dr. V. Sridevi  
*Department of Commerce,*  
*Ponnaiyah Ramajayam Institute of Science & Technology(PRIST)*

Contract Costing or Terminal Costing as it is often termed, is a variant of the job costing system, which is applied in businesses engaged in building or other construction work. The jobs are usually the contracts entered into with the customers. As the number of such contracts handled at a time by a business may not be usually large, Contract Costing is comparatively simpler in operation than job costing system. The basic principles applied in Contract Costing are the same as those used in job costing except that these are modified to suit the particular requirements of the contracts.

*Differences between Job costing and Contract costing:*

- (a) While the number of jobs in hand at any time in a concern may be large, only a few contracts may be undertaken at a time.
- (b) The accumulation, analysis, apportionment, allocation and control of costs is simplified in Contract Costing.
- (c) Most of the expenses are chargeable direct to the Contract Account. Direct allocation to such an extent is not possible in job costing.
- (d) As contracts may run for long periods, there arises the problem of assessment and crediting of profits on incomplete contracts at the end of the accounting period.

Contract Costing is a type of costing used in constructional activities such as construction of buildings, roads, bridges etc. The person who takes contract for a price is called the **Contractor** and the person from whom it is taken is called the **Contractee**. We are mainly concerned with the books of the contractor. To find out profit earned or loss incurred on the contract, the contractor prepares a nominal account in his books called 'Contract Account'. In this account, all the expenses incurred by the contractor are debited and the income i.e. mainly work certified is credited; the difference represents profit or loss.

The items generally debited are materials, wages, establishment expenses & other expenses. Depreciation of assets used in the contract will also be debited, but unlike in other types of accounts it is customary in Contract Accounts to debit the opening balance of the assets and credit the closing balance of the same instead of depreciation, wherever it is convenient to do so. Amounts credited are work-in-progress, which consists of work certified and cost of work uncertified and any scrap of materials etc. Further some special items which are discussed here under will also be taken care of.

The contracts run for or number of years; however it is necessary to find out the profit or loss at the end of every year. The profit earned on a Contract Account is primarily called **Notional Profit** and a portion of which would be kept on reserve against contingencies. The profit to be transferred to Profit & Loss Account out of notional profit is ascertained by taking into consideration the degree of completion of the work, cash received etc.

**CHAPTER –VIII PROCESS COSTING**  
Dr. R. Rajavardhini  
*Department of Commerce,*  
*Ponnaiyah Ramajayam Institute of Science & Technology(PRIST)*

**Process costing:**

Process costing is that aspect of operation costing which is used to ascertain the cost of the product at each process or stage of manufacture. This method of accounting used in industries where the process of manufacture is divided into two or more processes. The objective is to find out the total cost of the process and the unit cost of the process for each and every process. Usually the industries where process costing used are textile, oil industries, cement, pharmaceutical etc.

*Features of Process Costing:*

- (a) Production is done having a continuous flow of products having a continuous flow of identical products except where plant and machinery is shut down for repairs etc.
- (b) Clearly defined process cost centres and the accumulation of all costs by the cost centres.
- (c) The maintenance of accurate records of units and part units produced and cost incurred by each process.
- (d) The finished product of one process becomes the raw material of the next process or operation and so on until the final product is obtained.
- (e) Avoidable and unavoidable losses usually arise at different stages of manufacture for various reasons.
- (f) In order to obtain accurate average costs, it is necessary to measure the production at various stages of manufacture as all the input units may not be converted into finished goods.
- (g) Different products with or without by-products are simultaneously produced at one or more stages or processes of manufacture. The valuation of by-products and apportionment of joint cost before joint of separation is an important aspect of this method of costing.
- (h) Output is uniform and all units are exactly identical during one or more processes. So the cost per unit of production can be ascertained only by averaging the expenditure incurred during a particular period.

*Applications of Process Costing:*

The industries in which process costs may be used are many. In fact a process costing system can usually be devised in all industries except where job, batch or unit or operation costing is necessary. In particular, the following are examples of industries where process costing is applied:

Chemical works	Textile, weaving, spinning etc.
Soap making	Food products
Box making	Canning factory
Distillation process	Coke works
Paper mills	Paint, ink and varnishing etc.
Biscuit works	Meat products factory
Oil refining	Milk dairy



## CHAPTER –IX MARGINAL COSTING

Dr. R. Rajavardhini,  
*Department of Commerce,*  
*Ponnaiyah Ramajayam Institute of Science & Technology (PRIST)*

Marginal Cost is defined as “*the amount at any given volume of output by which aggregate costs are changed if the volume of output is increased or decreased by one unit.*” Marginal Cost also means *Prime Cost plus Variable Overheads*. Marginal Cost is a constant ratio which may be expressed in terms of an amount per unit of output. On the other hand, fixed cost which is not normally traceable to particular unit denotes a fixed amount of expenditure incurred during an accounting period. Fixed cost is, therefore, also called time cost, period cost, standby cost, capacity cost, or constant cost. Variable cost or marginal cost is also termed as direct cost, activity cost, volume cost or out-of-pocket cost.

From the above definition and analysis of marginal cost, we can understand that is the cost which varies according to the variations in the volumes of output. However, by definition marginal cost is the change in the total cost for addition of one unit. *It is to be noted that for an economist marginal cost and variable cost would be different. But for an accountant both marginal cost and variable cost are same and are interchangeably used.* Therefore, for our study, we use marginal cost and variable cost synonymously.

### **Marginal Costing:**

Marginal costing is “*the ascertainment of marginal costs and of the effect on profit of changes in volume or type of output by differentiating between fixed costs and variable costs.*” Several other terms in use like direct costing, contributory costing, variable costing, comparative costing, differential costing and incremental costing are used more or less synonymously with marginal costing.

It is a process whereby costs are classified into fixed and variable and with such a division so many managerial decisions are taken. The essential feature of marginal costing is division of total costs into fixed and variable, without which this could not have existed. Variable costs vary with volume of production or output, whereas fixed costs remain unchanged irrespective of changes in the volume of output. It is to be understood that unit variable cost remains same at different levels of output and total variable cost changes in direct proportion with the number of units. On the other hand, total fixed cost remains same regardless of changes in units, while there is inverse relationship between the fixed cost per unit and the number of units.

### **Features of Marginal Costing:**

The main features of Marginal Costing may be summed up as follows:

1. Appropriate and accurate division of total cost into fixed and variable by picking out variable portion of semi variable costs also.
2. Valuation of stocks such as finished goods, work-in-progress is valued at variable cost only.
3. The fixed costs are written off soon after they are incurred and do not find place in product cost or inventories.
4. Prices are based on Marginal Cost and Marginal Contribution.
5. It combines the techniques of cost recording and cost reporting.

## CHAPTER –X STANDARD COSTING & VARIANCE ANALYSIS

Dr. G. Karthiga,  
Department of Commerce,  
Ponnaiyah Ramajayam Institute of Science & Technology(PRIST)

### **Standard Cost:**

Standard Cost is defined as “*the predetermined cost that is calculated at the management’s standards of efficient operations and the relevant necessary expenditure*”.

From this we understand that it is the cost calculated when all the people working in the organisation to their utmost, the expenditure incurred for producing the product can be taken as standard cost. The optimum efficiency can not at all time exists. Therefore, optimum efficiency is assumed and that is why standard cost is called assumed cost. Further, all the inputs of cost scientifically analysed using so many industrial engineering techniques such as work measurement, method study, time and motion study, merit rating, job evaluation and other scientific techniques, it can also be called as Scientific Cost.

### **Standard Costs and Estimated Costs:**

The distinction between Standard Costs and Estimated Costs should be clearly understood. While both Standard Costs and Estimated Costs are predetermined costs, their objectives are different. The main differences between the two types of costs are:

1. Estimated Costs are intended to determine what the costs ‘will’ be. Standard Costs aim at what costs ‘should’ be.
2. Estimated Costs are based on average of past actual figures adjusted for anticipated changes in future. Anticipated wastes, spoilage and inefficiencies, all of which tend to increase costs are included in estimated costs. Standard Costs are planned costs determined on a scientific basis and they are based upon certain assumed conditions of efficiency and other factors.
3. In Estimated Costing Systems, stress is not so much on cost control, but costs are used for other purposes such as fixation of prices to be quoted in advance. Standard Costs serve as effective tools for cost control.

### **Setting of Standard Costs:**

While setting production costs standards, the following preliminaries should be considered:

- a. Study of the technical and operational aspects of the concern, such as methods of manufacture and the processes involved, management of organisation and line of assignment of responsibilities, division of the organisation into cost centres, units of measurement of input and output, anticipation of wastes, rejections and losses, expected efficiency, and capacity likely to be utilized.
- b. Review of the existing costing system and the cost records and forms in use.
- c. The type of standard to be used, i.e, whether current, basic, or normal standard costs are to be set. The choice of a particular type of standard will depend upon two factors, viz. which type would be most effective for cost control in the organization, and whether the standards will be merged in the accounting system or kept outside the accounts as statistical data.

### **Cost variance:**

The cost variance formula is a project cost management tool that can help you keep projects under budget. “Cost variance” is the difference between the expected cost of the project (or the amount budgeted) and the actual cost of the project (or the amount spent). When this value is positive, it indicates that a project is under budget, while a negative variance indicates that a project costs more than what you budgeted.

When you’re managing a project, calculate cost variance periodically in order to determine whether your project is staying on or under budget. You can even calculate individual variances for different budget categories, like labor or supplies, in order to find areas that are most likely to push a project over budget. In this post, we’ll explain what cost variance is and how you can apply the cost variance formula.

# **BANKING THEORY LAW AND PRACTICES**

EDITED BY

DR. S. KAMARAJU



978-93-6255-450-5

Banking Theory Law and Practice

Copyright © 2018 by Dr. S. Kamaraju

**All rights reserved. No part of this book may be reproduced or transmitted in any form or by any means without written permission from the author.**

ISBN: 978-93-6255-450-5

**Publisher: Ponnaiyah Ramajayam Institute of Science & Technology (PRIST)**

## TABLE OF CONTENTS

<b>CHAPTER – I.....</b>	<b>1</b>
<b>Role of Banking</b>	
<b>Dr. R. Selvaraj</b>	
<b>CHAPTER – II.....</b>	<b>8</b>
<b>Importance of Banking</b>	
<b>Dr. R. Selvaraj</b>	
<b>CHAPTER – II.....</b>	<b>16</b>
<b>Banking</b>	
<b>Dr.S.Rajendran</b>	
<b>CHAPTER – IV.....</b>	<b>24</b>
<b>E-Banking.</b>	
<b>Dr.S.Rajendran</b>	
<b>CHAPTER – V.....</b>	<b>32</b>
<b>Special Types of Bank Customers</b>	
<b>Dr. G. Karthiga</b>	
<b>CHAPTER – VI.....</b>	<b>41</b>
<b>Types of Banking</b>	
<b>Dr. G. Karthiga</b>	
<b>CHAPTER – VII.....</b>	<b>48</b>
<b>Commercial Bank</b>	
<b>Dr. D. Silambarasan</b>	
<b>CHAPTER-VIII.....</b>	<b>54</b>
<b>Investors Policy of a Commercial Bank</b>	
<b>Dr. D. Silambarasan</b>	
<b>CHAPTER IX.....</b>	<b>62</b>
<b>Investment Policy of a Commercial Bank</b>	
<b>Dr. R. Rajavardhini</b>	
<b>CHAPTER X.....</b>	<b>71</b>
<b>Electronic Fund Transfer</b>	
<b>Dr. R. Rajavardhini</b>	
<b>References.....</b>	<b>80</b>

## CHAPTER I ROLE OF BANKING

Dr. R. Selvaraj,

*Department of Commerce,*

**Ponnaiyah Ramajayam Institute of Science & Technology (PRIST)**

The recent financial turbulence in the US and Swiss banking sector has amplified the challenges surrounding monetary policy and inflation, adding to the complexities caused by various economic shocks such as the COVID outbreak, Russia-Ukraine conflict, and rising inflation. **Banks and financial institutions have a vital role in fostering economic growth and development by offering capital and financial services that empower businesses and individuals to thrive.** In this article, we will explore how banks support economic development and the positive impacts on communities, briefly touching on the subject.

- ***Financing infrastructure projects:*** One way in which banks support economic development is by providing financing for infrastructure projects. Infrastructure is essential for economic growth, and it requires significant investment. Banks help to finance large-scale projects such as roads, bridges, and airports, which can provide jobs, increase productivity, and drive economic growth. By providing financing for these projects, banks help to stimulate economic development and create opportunities for communities.
- ***Promoting financial inclusion:*** Financial inclusion is the idea that everyone should have access to financial services, regardless of their income level or geographic location. Banks promote financial inclusion by offering products and services that are tailored to the needs of underserved communities, such as mobile banking and microfinance. By promoting financial inclusion, banks help to reduce poverty, promote economic development, and build more resilient communities.
- ***Supporting international trade:*** Banks play a crucial role in supporting international trade by providing letters of credit, trade financing, and other services that help to facilitate cross-border transactions. By supporting international trade, banks help to promote economic growth and development, as well as foster greater global cooperation and understanding.
- ***Supporting small businesses:*** Small businesses are often the engines of local and regional economies. Banks support these businesses by providing access to capital and credit, as well as other financial services such as cash management and payroll processing. By supporting small businesses, banks help to create jobs, stimulate economic growth, and promote entrepreneurship.
- ***Encouraging savings and investment:*** Banks play an important role in encouraging savings and investment, which are essential for economic growth and development. By offering savings accounts and investment products, banks help individuals and businesses to build wealth and plan for their future. This, in turn, help to stimulate economic growth and development.

## CHAPTER II IMPORTANCE OF BANKING

**Dr. R. Selvaraj,**

*Department of Commerce,*

**Ponnaiyah Ramajayam Institute of Science & Technology (PRIST)**

### Importance of Banking

1. There are two types of Importance of banking: Primary and Secondary.

#### Primary

All banks have to perform two major primaries namely:

1. Accepting of deposits
2. Granting of loans and advances

#### Accepting of Deposits

A very basic yet important function of all the commercial banks is mobilising public funds, providing safe custody of savings and interest on the savings to depositors. Bank accepts different types of deposits from the public such as:

1. **Saving Deposits:** encourages saving habits among the public. It is suitable for salary and wage earners. The rate of interest is low. There is no restriction on the number and amount of **withdrawals**.
2. **Fixed Deposits:** Also known as Term Deposits. Money is deposited for a fixed tenure. No withdrawal money during this period allowed.
3. **Current Deposits:** They are opened by businessmen. The account holders get an overdraft facility on this account. These deposits act as a short term loan to meet urgent needs.
4. **Recurring Deposits:** A certain sum of money is deposited in the bank at a regular interval. Money can be withdrawn only after the expiry of a certain period.

#### Granting of Loans & Advances

The deposits accepted from the public are utilised by the banks to advance loans to the businesses and individuals to meet their uncertainties. Bank charges a higher rate of interest on loans and advances than what it pays on deposits. The difference between the lending interest rate and interest rate for deposits is bank profit.

Bank offers the following types of Loans and Advances:

1. **Bank Overdraft:** This facility is for current account holders. It allows holders to withdraw money anytime more than available in bank balance but up to the provided limit.
2. **Cash Credits:** a short term loan facility up to a specific limit fixed in advance. Banks allow the customer to take a loan against a mortgage of certain property (tangible assets and / guarantees).
3. **Loans:** Banks lend money to the customer for short term or medium periods of say 1 to 5 years against tangible assets. Nowadays, banks do lend money for the long term.

#### Secondary

Like Primary importance of Bank, the secondary are also classified into two parts:

1. Agency functions
2. Utility Functions

#### Agency Functions of Bank

Banks are the agents for their customers, hence it has to perform various agency functions as mentioned below:

**Transfer of Funds:** Transferring of funds from one branch/place to another.

**Periodic Collections:** Collecting dividend, salary, pension, and similar periodic collections on the clients' behalf.

**Periodic Payments:** Making periodic payments of rents, electricity bills, etc on behalf of the client.

**Collection of Cheques:** Like collecting money from the bills of exchanges, the bank collects the money of the cheques through the clearing section of its customers.

**Portfolio Management:** Banks manage the portfolio of their clients. It undertakes the activity to purchase and sell the shares and debentures of the clients and debits or credits the account.

**Other Agency Functions:** Under this bank act as a representative of its clients for other institutions. It acts as an executor, trustee, administrators, advisers, etc. of the client.

#### Utility Functions of Bank

- Issuing letters of credit, traveller's cheque, etc.
- Undertaking safe custody of valuables, important documents, and securities by providing safe deposit vaults or lockers.
- Providing customers with facilities of foreign exchange dealings
- Underwriting of shares and debentures
- Dealing in foreign exchanges
- Social Welfare programmes
- Project reports
- Standing guarantee on behalf of its customers, etc.

## CHAPTER III BANKING

Dr. S. Rajendran.,  
*Department of Commerce,*  
**Ponnaiyah Ramajayam Institute of Science & Technology (PRIST)**

### **What Is a Bank?**

A bank is a lawful organization that accepts deposits that can be withdrawn on demand. Banks are institutions that help the public in the management of their finances, public deposit their savings in banks with the assurance to withdraw money from the deposits whenever required.

Banks accept deposits from the general public and from the business community as well and give two assurances to the depositors –

1. Safety of deposit
2. Withdrawal of deposit, whenever needed

Banks give interest on deposits which adds to the original deposit amount and is a great incentive to the depositor. This promotes saving habits among the public. Bank also grants loans based on deposits thereby adding to the economic development of the country and well-being of the general public. With this stature, it becomes important to understand the major functions of a bank.

### **Banking:**

Banking is the system of financial institutions that provide financial services to individuals, businesses, and governments. Banks are intermediaries that accept deposits from depositors and lend them to borrowers.

Banking services include:

- Accepting deposits
- Lending money
- Facilitating transactions
- Offering financial products like savings accounts, loans, and credit cards

A bank is an institution that accepts customer deposits and offers loans to individuals and corporate clients. Banks make money by charging higher interest on loans than the interest they pay on customer deposits.



## CHAPTER IV E-BANKING

Dr. S. Rajendran.,  
*Department of Commerce,*  
Ponnaiyah Ramajayam Institute of Science & Technology (PRIST)

### **Meaning of E-Banking:**

Banks give administrations or bank services to draw in clients, from giving advances, issuing of debit cards and credit cards, computerised monetary services, and surprisingly personal services or administrations. Even so, some fundamental present-day administrations are presented by many commercial banks.

Electronic banking has many names like web-based banking, e-banking, virtual banking, or web banking, and online banking. It is just the utilisation of telecommunications networks and electronic networks for conveying different financial services and products. Through e-banking, a client can acquire his record and manage numerous exchanges utilising his cell phone or personal computer.

### **Classification of E-Banking:**

Banks offer different kinds of services through electronic financial stages. These are of three sorts:

#### **Type 1:**

This is the essential degree of administrations or services that banks offer through their sites. Through this assistance, the bank offers data, information regarding its services and products to clients. Further, a few banks might respond to an inquiry through email as well.

#### **Type 2:**

In this category, banks permit their clients to submit directions or applications for various administrations, check their record balance, and so on. Be that as it may, banks don't allow their clients to do any fund-based exchanges with respect to their records or accounts.

#### **Type 3:**

In the third category, banks permit their clients to work or operate their records or accounts for bill payments, purchase and redeem securities and fund transfers, and so on.

Most conventional banks offer e-banking administrations as an extra technique for offering support. Further, many new banks convey banking administrations principally through the other electronic conveyance channels or web. Likewise, a few banks are 'internet only' banks with no actual branch anyplace in the country.

## CHAPTER V SPECIAL TYPES OF BANK CUSTOMERS

**Dr. G. Karthiga,**

*Department of Commerce,*

*Ponnaiah Ramajayam Institute of Science & Technology*

During the opening of accounts, the banker deals with different types of customers. The banker should acquaint himself with various laws governing different types of customers. The customers can be classified as follows:

**1. Personal accounts:** The Banker should take care and verify certain facts while opening individual accounts. As per the Indian Contract Act 1872, a person is competent to enter into a valid contract and open a bank account provided:

- i) The individual should be major, i.e. of 18 years of age;
- ii) He should be of sound mind;
- iii) He is otherwise not disqualified by any law;
- iv) He should not be insolvent;
- v) Drunken person is not legally competent to enter into a contract;
- vi) He should be in good sense while lending a loan and entering into a contract.

**2. Hindu Undivided Family(HUF):** Hindu Undivided Family' otherwise known as 'Joint Hindu Family' property, business or ancestral estates and its common possession, enjoyment ownership is the basis of the formation of HUF.As per Hindu law, the Hindus, Buddhists, Sikhs & Jains can form HUF.

**3. Sole Proprietary Firms:** A business is wholly owned by an individual. In law, there is no difference between the proprietor & the firm. In all respects, it is an account in the name of an individual only except that it is operated upon by the proprietor on behalf of the firm. The firm should have PAN or GST Number. A proprietorship letter in the bank's Performa is to be obtained. Proof of proprietorship to be obtained. Creditors have recourse not only against assets of the firm but also against the private assets of the proprietor.

**4. Partnership Firm:** Partnership is the relation between persons who have agreed to share profits of business carried on by all or any one of them acting for all (Indian Partnership Act 1932). As per RBI instruction now Registration Certificate and Partnership deed to be obtained. The Indian Partnership Act does not mention anything about the maximum number of partners in a partnership firm. The Central Government has prescribed a maximum number of partners in a firm to be 50 vide Rule 10 of the Companies (Miscellaneous) Rules, 2014. Thus, in effect, a partnership firm cannot have more than 50 members".

**5. Limited Liability Partnership (LLP):** A limited liability partnership (LLP) is a partnership in which some or all partners (depending on the jurisdiction) have limited liabilities. LLP is governed by the Limited Liability Partnership Act 2008. Liability is limited to the extent of his contribution in the LLP. Minimum 2 designated partners and no limit on the maximum number of Partners. A partner is not liable for another partner's misconduct or negligence, except in certain cases.

**6. Companies:** Companies are defined in the Indian Company Act 1956. As per the provision of Company Act 2013 (implemented with effect from 1<sup>st</sup> April 2014), recognizes a joint Stock Company is a legal person with perpetual entity & is distinct from its members. A company or association of persons can be created at law as a legal person so that the company in itself can accept limited liability for civil responsibility.

## CHAPTER VI TYPES OF BANKING

Dr. G. KARTHIGA,  
*Department of Commerce,*  
Ponnaiyah Ramajayam Institute of Science & Technology (PRIST)

### 1) Central Bank

The Reserve Bank of India (RBI) serves as the Central Bank of India and is responsible for regulating and controlling the monetary and banking system in the country.

### 2) Commercial Banks

These are the most common types of banks and include public sector banks, private sector banks, and foreign banks. They provide various services like savings and current accounts, loans, and investments.

These are the most common types of banks and include public sector banks, private sector banks, and foreign banks. They provide various services like savings and current accounts, loans, and investments.

### 3) Cooperative Banks

A Co-operative Bank is registered under the Co-operative Societies Act of 1912 and is run by an elected managing committee. It works on a non-profit, no-loss basis and mainly serves entrepreneurs, small businesses, self-employment, and more in urban areas.

### 4) Payment Banks

The payment banks are a relatively new banking model in the country that has been conceptualised by the RBI. This bank is allowed to accept a restricted deposit. This amount is limited to Rs. 1 lakh for a customer. The bank also offers services such as ATM cards, net banking and more.

### 5) Small Finance Banks

These banks primarily serve the unserved and underserved sections of the population, including small businesses and low-income individuals.

This type of bank is licensed under Section 22 of the Banking Regulation Act 1949, and it is governed by the Provisions Act of 1934.

### 6) Scheduled Banks

These banks are covered under the 2nd Schedule of RBI Act 1934, and they need to have a paid-up capital of Rs. 5 lakhs or more.

### 7) Non-Scheduled Banks

The non-scheduled banks are local area banks that are not listed in the 2nd Schedule of the RBI Act 1934.

## CHAPTER VII COMMERCIAL BANK

Dr. D. Silambarasan,  
*Department of Commerce,*  
**Ponnaiyah Ramajayam Institute of Science & Technology (PRIST)**

### **Meaning:**

A commercial bank is a kind of financial institution that carries all the operations related to deposit and withdrawal of money for the general public, providing loans for investment, and other such activities. These banks are profit-making institutions and do business only to make a profit.

The two primary characteristics of a commercial bank are lending and borrowing. The bank receives the deposits and gives money to various projects to earn interest (profit). The rate of interest that a bank offers to the depositors is known as the borrowing rate, while the rate at which a bank lends money is known as the lending rate.

### **Function of Commercial Bank:**

The functions of commercial banks are classified into two main divisions.

#### **(a) Primary functions**

**Accepts deposit:** The bank takes deposits in the form of saving, current, and fixed deposits. The surplus balances collected from the firm and individuals are lent to the temporary requirements of the commercial transactions.

**Provides loan and advances :** Another critical function of this bank is to offer loans and advances to the entrepreneurs and business people, and collect interest. For every bank, it is the primary source of making profits. In this process, a bank retains a small number of deposits as a reserve and offers (lends) the remaining amount to the borrowers in demand loans, overdraft, cash credit, short-run loans, and more such banks.

**Credit cash:** When a customer is provided with credit or loan, they are not provided with liquid cash. First, a bank account is opened for the customer and then the money is transferred to the account. This process allows the bank to create money.

#### **(b) Secondary functions**

**Discounting bills of exchange:** It is a written agreement acknowledging the amount of money to be paid against the goods purchased at a given point of time in the future. The amount can also be cleared before the quoted time through a discounting method of a commercial bank.

**Overdraft facility:** It is an advance given to a customer by keeping the current account to overdraw up to the given limit.

**Purchasing and selling of the securities:** The bank offers you with the facility of selling and buying the securities.

**Locker facilities:** A bank provides locker facilities to the customers to keep their valuables or documents safely. The banks charge a minimum of an annual fee for this service.

**Paying and gathering the credit :** It uses different instruments like a promissory note, cheques, and bill of exchange.

## CHAPTER VIII INVESTMENT POLICY OF A COMMERCIAL BANK

**Dr. R. Rajavardhini,**  
*Department of Commerce,*  
**Ponnaiyah Ramajayam Institute of Science & Technology (PRIST)**

Before discuss about the investment policy by a commercial bank we have to distinguish between loans and investment. As all knows that higher risk gives higher returns and lower risk gives lower returns. The banks will provide loans for making short term profit, it will gives lower amount of profit to the bank. Bank loans otherwise known as bank credit .Commercial banks keeps a certain portion of its total deposit as a minimum reserve for meeting the demand of the depositors and lends out the remaining excess reserve to earn profit. On the other hand banks will invest his money for making long term profit, it will gives higher amount of profit to the bank. Thus a commercial bank will invest his money in real-estate, mutual fund, stocks, gilt edged securities, bonds, large scale industries etc.

As instructed by Reserve Bank of India, the investment policies of commercial banks are discussed below:-

- **Mandatory Investment**  
The mandatory investment of commercial bank will be made compulsory by RBI for controlling the money flow or credit control.
- **Advancing loans**  
Advancing loans is a function or a non mandatory investment by commercial bank. The loans-to-deposit ratio (LDR) is a simple measurement used to know the bank liquidity by comparing its total loans with its total deposits for the same periods of time.
- **Investment in other banks**  
If a bank facing deficit of money at that time another commercial bank may invest its surplus funds in any banks viz- commercial bank, public sector bank, private sector bank, co-operative banks.
- **Investment in government securities**  
Government securities are otherwise known as gilt edged securities will issued by either central government or state government and purchased by commercial banks. Due to most reliable and bear least risk a commercial always prefer to invest on these securities.
- **Investment in private companies**  
Investment in private companies is a risk full investment for commercial bank, but higher risk gives higher returns to the commercial banks.
- **Investment in other institutions, corporations and companies**  
Despite higher interest rate given by other institutions, corporations & companies, commercial bank will not invest its excess or surplus funds fund in any of these.

## CHAPTER IX INVESTMENT POLICY OF A COMMERCIAL BANK

**Dr. R. Rajavardhini,**  
*Department of Commerce,*  
**Ponnaiyah Ramajayam Institute of Science & Technology (PRIST)**

In modern banking a better investment policy is not only make profitability to commercial bank but also it will help to developing country for their growth and development. Thus to achieve maximum profits goal the bank will follow below principles: -

### 1) Liquidity

The actual meaning of liquidity is the ability of a bank to give cash on its customer demand. The most liquid assets of a bank is cash. A bank should choose such securities for investment which contain more liquidity. Such highly liquid securities are government bonds, government securities or gilt edge securities etc.

### 2) Safety or security

When an individual deposits their money in a bank they think about is their money or deposit safe or not. So commercial bank will assure to his customer about the deposits. Thus a commercial bank is a trustee of its customer. Therefore, it must be the greatest care by commercial bank in the matter of investing its customer's funds in the form of deposits.

### 3) Profitability

The most important objective of a commercial bank is to earn maximum profit to satisfy its all expenses and to make payments to its customers as interest. Therefore a commercial bank will invest its funds in such a manner to extract sufficient income with minimum cost. Thus a commercial bank should prefer to invest in such securing which will give maximum profit.

### 4) Stability

Floating interest rate is not secure and will not give a fixed rate of profit to the bank. So, a commercial bank should invest in those securities which give a fixed interest rate and possess a high degree of stability in their price. Such securities are viz- government securities or gilt edge securities, government bonds, government debentures and reputed companies.

### 5) Diversity

The commercial bank should invest its funds in different types securities or different industries for minimizing the risk. If a commercial bank choose only a single sector to invest funds it will not make profitable. So a commercial bank has to diversity its fund or surplus money in different types of sector.

### 6) Marketability

Meaning of marketability is the ability and attractiveness of a security to be sold easily. Thus a commercial bank should adopt the principle of marketability in investment policy. It helps to bank for easily saleable the securities and recovered profit with in short period of time.

## CHAPTER X ELECTRONIC FUND TRANSFER

Dr. R. Rajavardhini,  
*Department of Commerce,*  
Ponnaiyah Ramajayam Institute of Science & Technology (PRIST)

An electronic funds transfer (EFT), also known as a direct deposit, is the digital transfer of money between bank accounts. As digital transfers, they reduce the need for manual input and paper documents.

EFTs have become a popular mode of money transfer in the US because they are easy and don't require very much bank employee intervention. As such, they have made paper checks all but obsolete, especially for businesses that can save time and money using EFTs.

Anyone with a bank account can send money, including businesses and individuals. EFTs require two parties: the person or entity sending money and the person or entity receiving the money. The sender initiates the transfer over the internet or at a payment terminal. The transfer request is sent to the sender's bank and then back to the receiver's bank. EFTs are commonly used by businesses to pay employees, by utility companies to collect payment for services, and by retailers to pay suppliers. Most EFTs are completed (cleared) and funds are available to use within a couple of days.

### **What are the Different Types of Electronic Funds Transfer (EFT) Payments?**

Electronic Funds Transfer (EFT) is simple but can occur in a few different ways. The most common types of EFT payments are:

**Electronic Checks** – Sometimes called an e-check, this payment method generates a digital check as authorized by the payer. Many businesses use e-checks to pay their vendors.

**Direct Deposit** – Direct deposits bypass most of the paperwork of manual deposits and automatically deposit funds into an account. Many employees choose direct deposit as a payment option to eliminate a trip to the bank to deposit checks. The only requirement is a bank account. Users must also complete the initial set-up process, which may require some additional information.

**Phone Payments** – As the name implies, these EFTs happen over the phone. The payee supplies bank account information to the recipient and verbally authorizes the transaction. Phone payments are often used for utility payments.

**ATM Transactions** – ATM transactions are a type of EFT that relies on the digital transmission of info between a user's bank and the ATM machine. When a person withdraws cash from the machine, funds electronically transfer from the person's bank account and are physically dispensed through the machine instantly.

**Card Transactions** – When a person makes a purchase using a debit or credit card, either online or in person, account information is electronically received by the issuing bank, and a withdrawal in the amount of the transaction is approved. The payment is then scheduled and typically processes within one to two days.

**Internet Transactions** – With online transactions, users manually enter their payment card information into point of sale fields on a checkout page. Once that information is submitted by clicking a payment button, the issuing bank processes the payment approval. Just like with in-person card transactions, the payment is scheduled and funds are transferred within one to two days.

Electronic Funds Transfer (EFT) payments are quick, easy, and reliable. They require minimal effort from either the sender or recipient, making them an attractive solution for businesses and individuals alike.



# BUSINESS ACCOUNTING

Edited by  
**DR. R. SELVARAJ**



978-93-6255-547-2



Business Accounting

Copyright © 2018 by Dr.R.Selvaraj

All rights reserved. No part of this book may be reproduced or transmitted in any form or by any means without written permission from the author.

ISBN: 978-93-6255-547-2

Publisher: Ponnaiyah Ramajayam Institute of Science & Technology(PRIST)

## TABLE OF CONTENTS

CHAPTER – I.....	1
Introduction to Accounting	
Dr. R. Selvaraj	
CHAPTER – II.....	8
Importance of Accounting	
Dr. R. Selvaraj	
CHAPTER – III.....	15
Branch Accounts	
Dr.S.Rajendran	
CHAPTER – IV.....	22
Branch Accounts types	
Dr.S.Rajendran	
CHAPTER – V.....	30
Consignment Joint Venture	
Dr. G. Karthiga	
CHAPTER – VI.....	36
Installment Purchase System-I	
Dr. V. Sridevi	
CHAPTER – VII.....	44
Installment Purchase System-II	
Dr. V. Sridevi	
CHAPTER-VIII.....	52
Hire Purchase System-I	
Dr. R. Rajavardhini	
CHAPTER-IX.....	60
Hire Purchase System-II	
Dr. R. Rajavardhini	
CHAPTER X.....	65
Various of Accounting	
Dr. G. Karthiga	
REFERENCE.....	70

## CHAPTER I INTRODUCTION TO ACCOUNTING

**Dr. R. Selvaraj**

*Department of Commerce,*  
**Ponnaiyah Ramajayam Institute of Science & Technology (PRIST)**

Accounting is the system of recording financial transactions with both numbers and text in the form of financial statements. It provides an essential tool for billing customers, keeping track of assets and liabilities (debts), determining profitability, and tracking the flow of cash. The system is largely self-regulated and designed for the users of financial information, who are referred to as stakeholders: business owners, lenders, employees, managers, customers, and others. Stakeholders utilize financial statements to help make business, lending, and investment decisions.

Accounting has several specialized fields and roles. Private (internal) accounting generally refers to accountants who work within a single business entity. Small business accountants may assume general roles which require preparing the records (bookkeeping) and performing bank reconciliations. Accounting professionals are generally divided into three fields: tax, audit, and advisory. The tax field focuses on federal, state, and local tax filings. Audit roles test the validity of financial statements and internal controls. Advisory services perform general financial consulting. Public accounting firms have several different clients, whereas private accounting refers to working for one specific business entity.

### **Accounts**

There are five different types of accounts: asset, liability, equity, revenue, and expense. Each account type includes sub-accounts to record transaction details. For example, cash assets may include several different cash and savings accounts.

- **Asset accounts:** Cash and cash equivalents, accounts receivable, inventory, allowance for doubtful accounts (contra account), prepaid expense, investment, property, plant, and equipment, accumulated depreciation (contra account), intangible assets, accumulated amortization (contra account) and others
  - **Liability accounts:** Accounts payable, notes payable, accrued expenses, deferred revenue, long-term bonds payable and others
  - **Equity accounts:** Common stock, additional paid-in capital, retained earnings, treasury stock (contra account) and others

## CHAPTER II IMPORTANCE OF ACCOUNTING

Dr. R. Selvaraj,

*Department of Commerce,*  
Ponnaiyah Ramajayam Institute of Science & Technology (PRIST)

### *1. Keeps a record of business transactions*

Accounting is important as it keeps a systematic record of the organization's financial information. Up-to-date records help users compare current financial information to historical data. With full, consistent, and accurate records, it enables users to assess the performance of a company over a period of time.

### *2. Facilitates decision-making for management*

Accounting is especially important for internal users of the organization. Internal users may include the people that plan, organize, and run the organization. The management team needs accounting in making important decisions. Business decisions may range from deciding to pursue geographical expansion to improving operational efficiency.

### *3. Communicates results*

Accounting helps to communicate company results to various users. Investors, lenders, and other creditors are the primary external users of accounting information. Investors may be deciding to buy shares in the company, while lenders need to analyze their risk in deciding to lend. It is important for companies to establish credibility with these external users through relevant and reliable accounting information.

### *4. Meets legal requirements*

Proper accounting helps organizations ensure accurate reporting of financial assets and liabilities. Tax authorities, such as the U.S. Internal Revenue Service (IRS) and the Canada Revenue Agency (CRA), use standardized accounting financial statements to assess a company's declared gross revenue and net income. The system of accounting helps to ensure that a company's financial statements are legally and accurately reported.

## CHAPTER III BRANCH ACCOUNTS TYPES

**Dr.S.Rajendran,**  
*Department of Commerce,*  
*Ponnaiyah Ramajayam Institute of Science & Technology(PRIST)*

### **What Is Branch Accounting?**

Branch accounting is a bookkeeping system in which separate accounts are maintained for each branch or operating location of an organization. Typically found in geographically dispersed corporations, multinationals, and chain operators, it allows for greater transparency in the transactions, cash flows, and overall financial position and performance of each branch.

Branch accounting is a bookkeeping system in which separate accounts are kept for each branch or operating location of an organization. Technically, the branch account is a temporary or nominal ledger account, lasting for a designated accounting period.

Branch accounts can also refer to records individually produced to show the performance of different locations, with the accounting records actually maintained at the corporate headquarters. However, branch accounting usually refers to branches keeping their own books and later sending them into the head office to be combined with those of other units.

What are the rules of making record in branch Account?

Branch Account is debited with the opening balance of cash and further sum sent by Head Office to Branch. At the closing time, Branch Account is credited with the closing balance of Petty Cash. Thus, the petty expenses are automatically charged to Branch Account.

### **Important points:**

- Branch accounting is a bookkeeping system in which separate accounts are kept for each branch or operating location of an organization.
- Technically, the branch account is a temporary or nominal ledger account, lasting for a designated accounting period.
- Branch accounting provides better accountability and control since profitability and efficiency can be closely tracked for each location.
- Branch accounting has a long history, going back to the Venetian banks of the 14th century.

### **Some typical features of a branch**

A branch is not a separate legal entity, it is a part of the foreign-based company. A foreign company may only have one branch in Sweden.

The foreign-based company shall appoint a managing director to run the business activities in Sweden.

A branch is subject to Swedish law and the decisions of Swedish authorities regarding legal matters in connection with its business activities in Sweden.

A branch has no independent capital and its assets and liabilities are a part of the total assets of the foreign-based company.

## CHAPTER IV BRANCH ACCOUNTS TYPES

**Dr.S.Rajendran,**  
*Department of Commerce,*  
*Ponnaiyah Ramajayam Institute of Science & Technology(PRIST)*

Branches can be classified into two types.

### 1. Dependent Branches

The term dependent branch means a branch that does not maintain its own set of books. All records have to be maintained by the head office in case of a dependent branch.

Thus, the head office may keep accounts of the branch according to any of the following methods:

1. Debtors System.
2. Stock and Debtors system.
3. Final Accounting System.
4. Wholesale Branch system.

### 2. Independent Branch

An independent branch means a branch, which maintains its own set of books. Such a branch can either be a home branch or a foreign branch.

Related: Departmental Stores Accounts: Explanation, Importance (Explained).

The method of accounting is the same in both the case except that in case of a foreign branch, the trial balance sent by the foreign branch is to be converted into the currency of the country of the Head Office.

#### (A). Home Branch

Such a branch keeps a complete set of its books. It may also purchase goods from outside parties besides receiving goods from the head office.

It prepares its own trial balance and final accounts and sends its copies to the head office for their incorporation in the head office books. Thus, it maintains a head office account in its books this is of the nature of a personal account.

#### (B). Foreign Branch

In the case of a foreign branch, the accounting procedure is the same as in the case of a Home Branch.

**On receipt of the trial balance from the foreign branch,** the head office will scrutinize it and pass necessary entries for goods in transit, for cash in transit and other adjustments as may be necessary.

The trial balance of the foreign branch will have to be converted into home currency in the following manner.

## CHAPTER – V CONSIGNMENT JOINT VENTURE

**Dr. G. Karthiga,**  
*Department of Commerce,*  
*Ponnaiyah Ramajayam Institute of Science & Technology(PRIST)*

### CONCEPTS OF CONSIGNMENT

You know that goods are often sent by the producer on consignment basis to the selling agents or distributors. Let us now understand what exactly we mean by consignment, how does it differ from sale and what kind of relationship exists between the consignor and the consignee

What is Consignment?

When goods are sent by a manufacturer or a trader to an agent to be sold by him on commission basis and at the risk and account of the former, they are said to be sent on consignment. In other words a producer/trader forwards his products to his selling agents, appointed at different places, to sell them on his behalf for an agreed commission. The process of sending goods on this basis by one firm to another for sale is known as 'Consignment' and this transaction is called a 'Consignment Transaction'. The consignment is 'Outward Consignment' for the person who sends the goods and an 'Inward Consignment' for the person who receives the goods for sale.

Features of Consignment

- Goods are forwarded by the consignor to the consignee with an objective of sale at a profit.
- Under the consignment, goods are to be treated as the property of the consignor and to be sold at his risk entirely. The consignee does not buy the goods, he merely undertakes to sell them on behalf of the consignor. He is not responsible for any loss or even for any destructions or damages to the goods. But the consignee should not show any negligence.
- The consignor does not sell the goods to the consignee. Therefore, he can not ask the consignee to pay the price of the goods unless they are sold and the sale proceeds are actually realised.
- The consignee agrees to sell the goods for an agreed rate of commission and is allowed to deduct his commission due from the sale proceeds.
- The agent enters into the picture only when he sells the goods and realises the amount. He becomes indebted for amounts realised on behalf of the principal. The relationship between the consignor and the consignee is that of a principal and an agent.
- As it is not a sale, whatever the consignee does is on behalf of the consignor and, therefore, all legitimate expenses incurred by the consignee for receiving and selling the goods should be reimbursed.
- Any stock remaining unsold with the consignee belongs to the consignor.
- As the consignee acts on behalf of the consignor, the profit or loss on sale of goods sent on consignment belongs to the consignor.

## CHAPTER – VI INSTALLMENT PURCHASE SYSTEM-I

Dr. V. Sridevi

*Department of Commerce,*

*Ponnaiyah Ramajayam Institute of Science & Technology(PRIST)*

Purchase system is a special system of purchase and sale of goods. Under this system purchaser pays the price of the goods in instalments. The instalments may be annual, six monthly, quarterly, monthly fortnightly etc.

Thus Purchase means a transaction where the goods are sold by vendor to the purchaser under the following conditions:

- The goods will be delivered to the purchaser at the time of agreement. The purchaser has a right to use the goods delivered.
- The price of the goods will be paid in instalments.
- Every instalment will be treated to be the hire charges of the goods which is being used by the purchaser.
- If all instalments are paid as per the terms of agreement, the title of the goods is transferred by vendor to the purchaser.
- If there is a default in the payment of any of the instalments, the vendor will take away the goods from the possession of the purchaser without refunding him any amount received earlier in the form of various instalments.

### **Characteristics of Purchase System**

The characteristics of Purchase system are as under

- Purchase is a credit purchase.
- The price under Purchase system is paid in instalments.
- The goods are delivered in the possession of the purchaser at the time of commencement of the agreement.
- Hire vendor continues to be the owner of the goods till the payment of last instalment.
- The Purchaser has a right to use the goods as a bailer.
- The Purchaser has a right to terminate the agreement at any time in the capacity of a hirer.
- The Purchaser becomes the owner of the goods after the payment of all instalments as per the agreement.

### **Difference between Purchase system and Instalment payment system**

- In Purchase system, the transfer of ownership takes place after the payment of all instalments while in case of Instalment payment system, the ownership is transferred immediately at the time of agreement.
- In Purchase system, the Purchase agreement is like a contract of hire though later on it may become a purchase after the payment of last instalment while in Instalment payment system, the agreement is like a contract of credit purchase.
- In case of default in payment, in Purchase system the vendor has a right to back goods from the possession of the Purchaser while in case of Instalment payment system, the vendor has no right to take back the goods from the possession of the purchaser; he can simply sue for the balance due.
- In Purchase system, if the purchaser sells the goods to a third party before the payment of last instalment, the third party does not get a better title on the goods purchased. But in case of Instalment payment system, the third party gets a better title on the goods purchased.
- In Purchase system the provisions of the Purchase Act apply to the transaction while in case of Instalment payment system, the provisions of Sale of Goods Act apply to the transaction.



## CHAPTER – VII INSTALLMENT PURCHASE SYSTEM-II

Dr. V. Sridevi  
*Department of Commerce,  
Ponnaiyah Ramajayam Institute of Science & Technology(PRIST)*

Different Types of Instalment Systems

### **Instalment Sales:**

Arrangement between buyer and seller. Goods are paid for in a series of instalments instead of upfront. Commonly facilitated by third-party payment service providers (e.g., Klarna).

### **Instalment Loans:**

Loan obtained from a financial institution. Repaid in periodic instalments. Typically incurs interest on the outstanding balance.

### **Instalment Debt:**

Large outstanding debt repaid in instalments. Example: HMRC offered this service to SMEs during the pandemic.

A point worth noting about Merchant Relevance: Instalment sales are most useful for merchants as they facilitate customer purchases by spreading costs over time, increasing flexibility and potential for increased sales.

Benefits of Instalment Payments

### **Benefits for the Customer:**

**Financial Tracking:** This is meant to improve cash flow monitoring and control.

**Cost Stretching:** With this feature, a customer can spread their expenditure budget across payment cycles in a way that makes it possible to make financial decisions without having limited expenses.

**Budget Adherence:** Assists customers in staying within their budget.

**Low Monthly Payments:** These involve cheaper payment methods that are also simple to monitor.

### **Benefits for the Business:**

**Customer Flexibility:** Allows adaptability, hence, draws in bigger clientele.

**Increased Sales:** Encourages more purchases, boosting sales.

**Cash Flow Regulation:** Helps control and keep a steady stream of cash.

**CHAPTER – VIII HIRE PURCHASE SYSTEM-I**  
**Dr. R. Rajavardhini,**  
*Department of Commerce,*  
*Ponnaiyah Ramajayam Institute of Science & Technology(PRIST)*

A Hire Purchase System is a system in which the hirer purchases goods from the vendor but does not pay him in full. Instead, he makes a lump sum payment known as a down payment, and the remainder is paid in instalments by the purchaser of the goods. It is similar to an instalment system, but the basic difference between an instalment system and a hire purchase system is the time to transfer the ownership.

Parties involved in the hire purchase systems are Hirer: A “Hirer” is a purchaser of a good or an individual who acquires a good or service from the proprietor or vendor under the recruit buy framework.

### **Hire Purchase Meaning: Characteristics of Hire Purchase System**

The Hire Purchase System offers a wide range of leverage to the hirer as it offers a chance to pay half of the amount in instalments. Some of the major features of the same are discussed below:

1. Regulations: Compliant with the Employment Purchase Act of 1972.
2. Parties: The leasing of resources is an agreement between residents and managers.
3. Exercise of Rights: If the resident fails to pay, the property owner may use or request the return of the property, not the remaining parts.
4. Right to sell: Tenants may not sell or mortgage investment property until the property has been transferred.
5. Failure: Hire Vendor is solely responsible for any loss until the ownership gets transferred to the hirer of the good.

### **Hire Purchase Meaning: Hire Purchase Varieties**

- Purchase of Consumer Hire: The buyer, in this case, hires the goods for non-business purposes, i.e. for personal use. Aside from business, this could also be for family or other domestic purposes. The natural person, not the business, is the hirer in this situation.
- In contrast to the preceding example, the hirer, in this case, is a firm or industry that takes things on hire for business purposes. Consider the hire purchase of industrial machinery as an example.

### **Hire Purchase Meaning: Hire Purchase Agreements Have Several Advantages**

Hire purchase agreements may be used by businesses with limited working capital to deploy assets. As the payments are recorded in expenses, they may be more tax-efficient than that of standard loans in which any depreciation tax benefits will offset the savings.

## CHAPTER –IX HIRE PURCHASE SYSTEM-II

**Dr. R. Rajavardhini,**  
*Department of Commerce,*  
*Ponnaiyah Ramajayam Institute of Science & Technology(PRIST)*

The rent-to-own concept is very similar to hire purchase. The lessee will pay the rent for a property or a vehicle over a period of time. If the lessee pays the actual sale price of the property or vehicle, he will have the option to own the property or vehicle at any time.

### **Benefits of Hire Purchase Agreements**

The opportunity to purchase more expensive goods than an individual or business could typically afford is the principal benefit of employing hire purchase agreements. The fact that the payments are spaced out over time makes them less onerous for the buyer and enables them to buy a more expensive asset. Because a hire purchase agreement is not seen as an extension of credit, it can be used even by those with bad credit or who have reached their credit limit.

Similarly, hire buy arrangements might benefit companies with little or no working capital. As long as all installments are made, ownership of the item is not transferred until then, posing no danger to the seller because the item may be repossessed at any time if payments are not made. Since there is no extension of credit involved in the arrangement, consumers may use the payment plan in an interesting way.

Along with the buyer, vendors profit from hire purchase agreements. Given that more people can afford the pricey items, the majority of the benefit comes from the increasing demand for their product. Hire contracts ultimately increase the company's revenue and broaden its consumer base. The benefits of the buyer's accrued interest, which they will receive in the subsequent installments, accrue to the corporation if they are self-financing the product.

### **Drawbacks of Hire Purchase Agreements**

The hire purchase contract has drawbacks for both the vendor and the buyer. In an effort to buy pricey items outside of their budget, the consumer frequently goes overboard and ends up being saddled with additional expenses.

Furthermore, interest payments might be very expensive, especially when compared to outright buying the things at the beginning. The risk of entering into a hire agreement is increased by the lack of explicit disclosure of the interest rates.

Hire purchase agreements can result in challenging organizational and administrative chores on the part of the vendors, which ultimately raises expenses for the business.

## CHAPTER –X Various of Accounting

Dr. G. Karthiga,  
Department of Commerce,  
Ponnaiyah Ramajayam Institute of Science & Technology(PRIST)

Accounting is often called the language of business. Accounting is the language of business. Recording and summarizing business and financial transactions and analysing, verifying, and reporting the results. The accounting function in a small business is vital because it allows the firm owner or accountant to assess both historical and current financial data in a way that benefits all stakeholders.

The three types of accounting include cost, managerial, and financial accounting. Although 3 methods of accounting are both vital to the healthy functioning of a business, they have different meanings and accomplish different goals. Let's dive into each of each below.

### Financial Accounting

The primary function of financial accounting is to track, record, and recap all daily types of accounting transactions into monthly, quarterly, and yearly financial statements. From the financial statements, the owners and financial managers can perform multiple forms of financial analysis, such as Common size financial statement analysis or Ratio analysis. The result from the analysis is reported to the stakeholders later. In short, financial accounting provides a general look at business performance over a period of time in the form of financial statements – the Balance Sheet, Income Statement, and Statement of Cash Flows, and "financial reporting" to your description would make it more comprehensive.

### Managerial Accounting

Managerial accounting can be easily mistaken for financial accounting, but actually, they are two different aspects. Managerial accounting is the process of organizing financial data and reporting financial status to managers. Thereby helping business managers make optimal operating decisions and grasp the issues as soon as possible if there are any. Management accounting information is especially important in operating an enterprise, and at the same time serves to control and evaluate that business.

While financial accounting can be publicly shared with stakeholders, management accounting information is shared exclusively with others in an organization due to the sensitive nature of the information.

Three common types of management accounting are used:

- Strategic management
- Performance management
- Risk management

### Cost Accounting

Costing accounting is a specialty field that looks closely at the actual cost related to the accomplishment of a business goal. Cost accounting plays an important role in optimizing production processes in order to reduce costs for businesses and bring higher profits for individual product sales.

The costs of producing a product for a business can be categorized as fixed and variable costs.

**Fixed costs:** The type of costs that do not change with the amount of product that is manufactured. Fixed costs remain the same regardless of whether goods or services are produced or not. Thus, a company cannot avoid fixed costs. The most common examples of fixed costs include lease and rent payments, utilities, insurance, and interest payments.

**Variable costs:** The costs that change with the production quantity of products made or the performance of services. Common examples of variable costs include costs of goods sold (COGS), raw materials, packaging, commissions, and certain utilities such as gas or electricity.

# PRINCIPLES OF MANAGEMENT

*Edited by*  
**DR. S. RAJENDRAN**



978-93-6255-131-3

Principles of Management  
Copyright © 2018 by Dr. S. Rajendran

All rights reserved. No part of this book may be reproduced or transmitted in any form or by any means without written permission from the author.

ISBN: 978-93-6255-131-3

Publisher: Ponnaiyah Ramajayam Institute of Science & Technology (PRIST)

## TABLE OF CONTENTS

CHAPTER-I.....	1
NATURE AND FUNCTIONS OF MANAGEMENT	
Dr.S.Rajendran	
CHAPTER-II.....	7
EVOLUTION OF MANAGEMENT THOUGHT	
Dr. G. Karthiga	
CHAPTER-III.....	15
PLANNING AND DECISION MAKING	
Dr. G. Karthiga	
CHAPTER-IV.....	22
ORGANISING AND ORGANISATION STRUCTURE	
Dr.S.Kamaraju	
CHAPTER-V.....	31
STAFFING	
Dr. G. Karthiga	
CHAPTER-VI.....	40
DIRECTION AND SUPERVISION	
Dr. V. Sridevi	
CHAPTER-VII.....	47
CONTROLLING AND CO-ORDINATION	
Dr. R. Rajavardhini	
CHAPTER-VIII.....	52
COMMUNICATION, MOTIVATION AND LEADERSHIP	
Dr. D. Silambarasan	
CHAPTER-IX.....	61
SOCIAL RESPONSIBILITIES OF BUSINESS	
Dr. R. Rajavardhini	
CHAPTER-X.....	70
STRATEGIC MANAGEMENT	
Dr. G. Karthiga	
REFERENCES.....	75

## CHAPTER –I NATURE AND FUNCTIONS OF MANAGEMENT

Dr.S.Rajendran,

*Department of Commerce,*

*Ponnaiyah Ramajayam Institute of Science & Technology(PRIST)*

### **Definition of Management:**

Management is a vast and extensive subject. It is therefore, not possible to put all the essential features of management in a single formula.

### **Nature of Management:**

**Management is Goal-Oriented:** The accomplishment of several management activities advances by its appearance of its planned aims or objective. Management is involved in descriptive action.

**Management integrates Human, Physical and Financial Resources:** In an organisation, communal presence functions with non-human reserves like instruments, components, financial inventories, frameworks etc.

**Management is Continuous:** Management is basically an on-going approach which encompasses responding of difficulties as well as handling that the objective of an establishment continues as utmost development mechanism.

**Management is all Pervasive:** Management continues imperative in conclusive categories of organisations whether it continues political, communal and cultural or business which will handle and commands complex behaviours towards a perfect approach.

**Management is a Group Activity:** Management is not as concerned with individual efforts as it is about groups and team work. It involves the use of teamwork to achieve predetermined goal of management.

**Principles are Dynamic in Nature:** Principle is a fundamental truth, which establishes cause and effect relationships of a function within a set- up.

**Principles are Relative, not absolute:** Management principles are relative, not absolute and they should be applied according to the need of the organisation. The organisational difference between organisations may exist because of time, place, socio-cultural factors, etc.

**Management is a Science, Art and Profession:** There is a controversy whether management is science or art. However, management is both a science and an art because it follows principles of science and requires the skills of an art. Management has been regarded as a profession by many while many have suggested otherwise.

**Management is Decision-Making:** Management process involves decision- making at various levels. This usually includes delegation of work.

### **Functions of Management:**

Planning

Organizing

Staffing

Directing

Controlling

Co-Coordinating



## CHAPTER –II EVOLUTION OF MANAGEMENT THOUGHT

Dr. G. Karthiga,  
*Department of Commerce,*  
*Ponnaiyah Ramajayam Institute of Science & Technology(PRIST)*

Management is considered as the significant feature of economic life of mankind throughout ages. Management thought is regarded as an evolutionary concept. It has developed along with it and in line with social, cultural, economic and scientific institutions. Management thought has its origin in ancient times. It is developed along with other socio economic development. The contributors to management theory include management philosophers, management practitioners, and scholars. Modern management is based on the strong foundation laid down by the management thinkers from the past events.

### The Concept of Evolution of Management Thought

To understand the entire concept of evolution of the management thought, the topic is divided into 4 major stages, which are as follows:

- Pre-scientific management period
- Classical theory
- Neo-classical theory (or behavior approach)
- Bureaucratic Model of Max Weber

### Pre-Scientific Management Period

As the industrial revolution occurred in the 18th century, there was a huge impact on management. The scenario changed the method of raising capitals, organizing labor, and goods' production for the individuals and businesses. Entrepreneurs then had access to production factors like land, labor, and capital. The final step was only to make some effort to combine these factors to achieve the target successfully.

### The Classical Theory

Robert Owens, Charles Babbage, and other prominent personalities are regarded as management's pioneers. However, their contribution to the evolution of management is lower. Further, by the last decade of the 19th century, the science of management began, and with it, some professionals like H. L. Grant, F. W. Taylor, Emerson, and others entered for the establishment of scientific management.

### The Neo-Classical Theory

This duration of the evolution of management thought is a better version of classical theory. It is a modified version of classical theory with several improvements. The classical theory focused mainly on the areas of job including physical resources and their management, but Neoclassical theory focuses on employee relationships in the work ecosystem.

### The Bureaucratic Model

Max Weber, a German sociologist, proposed the bureaucratic model. This includes a system of labor division, rules, authority hierarchy, and employees' placement based on their technical capabilities.

## CHAPTER –III PLANNING AND DECISION MAKING

Dr. G. Karthiga,  
Department of Commerce,  
Ponnaiyah Ramajayam Institute of Science & Technology(PRIST)

Successful managers try to envisage the problems before they turn into emergencies. As pointed out by Terry, “successful managers deal with foreseen problems and unsuccessful manager’s struggle with unforeseen problems. The difference lies in planning.”

A plan is a forecast for accomplishment. It is a prearranged course of action for tomorrow’s activity. In other words, to plan is to prepare a blue print for future action, to bring about specific results at a specific cost in a specific period. Management thinkers have defined the term in two ways:

### *Based on futurity:*

- Planning is a trap laid down to capture the future. (Allen)
- Planning is deciding in advance what is to be done in future. (Koontz).
- Planning is informed anticipation of future. (Haimann)
- Planning is „anticipatory“ decision-making. (R.L, Ackoff)

### *Based on thinking:*

- Planning is a thinking process, an organised foresight, a vision based on fact and experience that is required for intelligent action. (Alford and Beatt)
- Planning is deciding in advance what to do, how to do it, when to do it and who is to do it. (Koontz and O’Donnell)

### Meaning of Decision Making

Decision-making can be considered as the cognitive process resulting in the selection of a course of action among several available alternatives. It is found that all decision making process will generate a final choice where the output can be perceived as an opinion.

### Characteristics of Decision-Making

The important characteristics of decision-making may be listed thus:

- **Goal-oriented:** Decision-making is a goal-oriented process. Decisions are usually prepared to attain some purpose or goal. The intention is to move towards some anticipated state.
- **Alternative:** A decision should be viewed as „a point reached in a stream of action.“ It is characterized by two activities- search and choice. The manager searches for opportunities, to arrive at decisions and for alternative solutions, so that action may take place.
- **Analytical-Intellectual:** Decision-making is not only an intellectual process but also an intuitive one. It involves conscious and unconscious aspects. Part of it can be learned, but part of it depends upon the personal characteristics of the decision maker.
- **Dynamic Process:** Decision-making is characterized as a process, rather than as one static entity. It is a process of using inputs effectively in the solution of selected problems and the creation of outputs that have utility. Moreover, it is a process concerned with „identifying worthwhile things to do“ in a dynamic setting.
- **Pervasive Function:** Decision-making permeates all management and covers every part of an enterprise. Decision-making is the crux of a manager’s job. Everything that the manager does is backed by the power of decision – making.

Dr.S.Kamaraju,  
*Department of Commerce,*  
*Ponnaiyah Ramajayam Institute of Science & Technology(PRIST)*

**Organising** is the management function wherein organisational resources are allocated and responsibilities are delegated in order to accomplish long-term organisational goals. It ensures efficient use of organisational resources. It is related with building up of a framework or structure of various interrelated parts. We can say that organising is a process consisting of a series of steps by which managers create a network of authority responsibility relationship. It helps people to work together (relate to one another) for a common objective.

### **Characteristics of Organising**

Organising is one of the basic and important elements or functions of management. To get things done by others, a manager has to organise their activities

It is a goal-oriented process. It is only to accomplish certain goals that the process of organising is designed for. The structure of an organisation is designed so as to facilitate performance of large number of activities.

The organising process chiefly deals with group efforts, which are made to achieve common goals.

Organising is based on the principle of division of work and specialisation.

It involves the processes of differentiation or division of activities and integration of activities by grouping them.

The process of organising aims at interrelating, mobilising and coordinating the activities of employees.

It establishes authority relationship of superior and subordinate among the employees by assigning the activities and delegating adequate authority to them.

### **Structure of an Organisation:**

The structure of an organisation is a network of authority and responsibility assumed by and delegated to the employees. Organisational structure defines the pattern of formal relationship between superiors and subordinates. It may also be regarded as a network of role, relationship, assigned work and delegated authority to employees. It provides the basis on which the managers and non-managerial employees perform the job assigned to them.

### **Classification of Organisational Structure**

Various activities are grouped together to create departments and units and their relationships in the organisation is thus prescribed. On the basis of this, the organisational structure is classified. Thus, there are seven types of organisation structure:

- Line
- Line and staff
- Functional
- Divisional
- Project
- Matrix
- Free-from (virtual organization)

**Dr. G. Karthiga,**  
*Department of Commerce,*  
*Ponnaiyah Ramajayam Institute of Science & Technology(PRIST)*

According to Theo Haimann, “Staffing pertains to recruitment, selection, development and compensation of subordinates.”

***Nature of Staffing can be explained by the following characteristics:***

Staffing is an important managerial function: Staffing function is the most important managerial act along with planning, organising, directing and controlling.

Staffing is a pervasive activity: As the function of staffing is carried out by all managers and in all types of concerns where business activities are carried out.

Staffing is a continuous activity: This is because staffing function continues throughout the life of an organisation due to the transfers and promotions that take place.

The basis of staffing function is efficient management of personnel: Human resources can be efficiently managed by a system or proper procedure, that is, recruitment, selection, placement, training and development, providing remuneration, etc.

***Importance of Staffing:***

Key to other managerial functions: It is seen that function of staffing is closely related to managerial business areas which influences direction and control in organisation.

Building healthy human relationships: It builds the required man-power relationships in an organisation. With smooth human relation, excellent coordination and communication takes place.

Human resources development: For any business establishment, hardworking and skilled man-power is welcomed prerequisite which serves as an asset of a business concern.

Long Term effect: The work operations of the company depend upon the effective decision making quality. It is noted that skilled, laborious and well-motivated people becomes an asset to an organisation.

***Staffing Process-Steps involved in Staffing:***

Manpower requirements: It is seen that the first step towards staffing is planning of good manpower which will match the need of particular work.

Recruitment: As per the demand from the organisation, the applications of concerned workers are entertained as per invitations by company to the desired candidate.

Selection: After receiving applications from candidates, they are scanned as per suitability of position and candidature.

Orientation and Placement: After a job proposal is given to the candidate, the initial work is to make the candidate familiar with working style and environment.

Training and Development: Training is part of inducements which is provided to worker so as to frame and grow as per the concern. It involves working capability and scope.

Remuneration: It is the sort of compensation which is paid by the concern to the new joiners. It depends on nature of job skilled or unskilled, physical or mental, etc.

Performance Evaluation: Performance evaluation is a method which will record candidate behaviour, attitudes and progress. It involves regular assessment based on reports from different departments.

Promotion and transfer: It involves transfer in job sector and level which depends on past performance of the candidate. It is non- monetary incentive.

## CHAPTER –VI DIRECTION AND SUPERVISION

Dr. V. Sridevi,  
Department of Commerce,  
Ponnaiyah Ramajayam Institute of Science & Technology(PRIST)

### ***Definition of Directing***

In the words of Urwick and Brech, “directing is the guidance, the inspiration, the leadership of those men and women that constitutes the real core of the responsibility of management.”

Thus directing involves, issuing orders and instructions, overseeing of the subordinates and supervising the work being performed by them.

According to Haiman, “Directing consists of a process or technique by which instruction can be issued and operations can be carried out as originally planned.” Broadly, the process of directing involves the following elements:

- Issuing orders and instructions to the subordinates regarding the work being performed by them.
- Guiding, counselling and educating the subordinates and telling them the way of doing the given job.
- Supervising the work being performed by them on the regular basis to ensure that they have been working according to the plan.

### ***Nature of Directing***

**1.Pervasive Function:** As directing is essential at every levels in an organisation, so it is the duty of the manager to give related guidance and to boost his subordinates.

**2.Continuous Activity:** In an organisation, direction serves as continuous activity throughout life in an organisation.

**3.Human Factor:** It is seen that directing is associated with subordinates and as human factor. As both are complex and unpredictable, hence direction serves as an important part.

**4.Creative Activity:** With direction, you can alter any plans into performance as in the absence of this; people will become stationary and physical resources results in no meaning.

**5.Executive Function:** As seen, direction is done with all managers and executives at certain levels without working of an enterprise.

**6.Delegate Function:** It is a function which is related to direction that deals with human beings.

### ***Importance of Directing:***

Directing is at the core of managing process. The presentations of various accomplishments in organisation revolve around it. In spite of sound planning, a suitable organisational structure, effective staffing and efficient controlling, the desired results may not be obtained without proper directing. It is only through directing process, the organisational actions are commenced for attaining its objectives.

In detail, the importance of directing can be understood on the basis of the following factors

- Directing helps in achieving Co-ordination
- It is a means of motivation
- Directing supplements other managerial functions
- Directing helps in coping with changing environment
- Directing facilitates order and discipline among employees

## CHAPTER –VII CONTROLLING AND CO-ORDINATION

Dr. R. Rajavardhini,  
*Department of Commerce,*  
*Ponnaiyah Ramajayam Institute of Science & Technology(PRIST)*

According to Brech, “Controlling is a systematic exercise which is called as a process of checking actual performance against the standards or plans with a view to ensure adequate progress and also recording such experience as is gained as a contribution to possible future needs.”

### Features of Controlling

**Control is a Positive Force:** The primary object of control is to find areas of failure, and who is responsible for them and remedial actions to be taken. It is thus a positive force, aimed at securing performance. Just like a thermostat in a refrigerator control automatically begins to operate whenever deviations occur. It is a constructive activity designed to check deviations and advance performance.

**Controls Continuous Process:** It is not a one-step action plan. As pointed by the navigator continually takes readings to ascertain where he is, relative to a planned course, so should the business manager continually take readings to assure him that his enterprise or department is on course.”

**Control is Forward Looking:** Control involves a post-mortem examination of past events; it is often viewed negatively, as a policing or watchdog kind of job. The whole exercised of looking back is meant to improve performance in future, as past cannot be controlled.

**Control Process is Universal:** Control is a primary function of every manager. It has to be undertaken at every level. Managers at every level have to check deviations from standards; set it right immediately and keep the business on course. The, process of management is incomplete without controlling.

**Control Process is Dynamic:** Control is not static; it is dynamic in the sense, it is amenable to change and hence, highly flexible. Between the establishment and achieving of the goal many things can happen in the organisation and its environment to disrupt or slow the pace of movement toward the goal or even to change goal itself. “A properly designed control system can help managers anticipate, monitor and respond to changing circumstances.”

**Control is Goal-Oriented:** Control guides activities (along desired lines) towards predetermined goals. The primary focus is on achieving results, checking deviations, if any and initiating timely remedial steps. Control, thus, is not an end in itself but only a means to achieve predetermined goals.

**Delegation is the Key to Control:** A manager gets authority to use resources and achieve results through delegation. Without such authority, a manager may not be in a position to take effective rectification steps in time.

## CHAPTER –VIII COMMUNICATION, MOTIVATION AND LEADERSHIP

Dr. D. Silambarasan,  
*Department of Commerce,*  
*Ponnaiyah Ramajayam Institute of Science & Technology(PRIST)*

### **Communication:**

Alien Louis A: Communication is the sum of all the things one person does when he wants to create understanding in the mind of another. It involves a systematic and continuous process of telling, listening and understanding.

### **Nature of Communication**

**Completeness:** The communication must be complete. It should convey all facts required by the audience. The senders of the message must take into consideration the receiver's mind set and convey the message accordingly.

**Conciseness:** Conciseness means wordiness, i.e. communicating what you want to convey in least possible words without forgoing the other C's of communication. Conciseness is a necessity for effective communication.

**Consideration:** Consideration implies "stepping into the shoes of others". Effective communication must take the audience into consideration, i.e. the audience's viewpoints, background, mind-set, education level, etc.

**Clarity:** Clarity implies emphasizing on a specific message or goal at a time, rather than trying to achieve too much at once.

**Courtesy:** Courtesy in message implies the message should show the sender's expression as well as should respect the receiver. The sender of the message should be sincerely polite, judicious, reflective and enthusiastic.

**Correctness:** Correctness in communication implies that there are no grammatical errors in communication.

**Motivation:** "Any emotion or desire which so conditions one's will that the individual is propelled in to action." Stanley Vence.

"The complex of forces starting and keeping a person at work in an organisation": Robert's Encyclopaedia of Management

### **Importance of Motivation**

**Effective use of resources:** In business, all physical resources are to be used through human force. Effective and competent use of these resources depends on the ability and reading of work force

**Higher efficiency:** Motivation is directly related to the level of efficiency. Highly motivated employees make full use of their energy and other abilities that raise the existing level of efficiency. They produce more as compared to other employees.

**Accomplishment of organisational goals:** The process of motivation helps in shaping the working behaviour of the employees and making it desirable for achieving objectives. Highly motivated employees would make goal directed efforts. They are more committed and cooperative for seeking organisational goals.

**Leadership:** "Leadership is a process of giving purpose (meaningful direction) to collective effort and causing willing effort to be expended to achieve purpose." (Jacobs and Jaques)

### **Leadership Styles**

Leadership style is the manner and approach of providing direction, implementing plans and motivating people. Kurt Lewin (1939) led a group of researchers to identify different styles of leadership. This early study has been very influential and established three major leadership styles. The three major styles of leadership are:

- Authoritarian or autocratic
- Participative or democratic
- Delegated or free reign

## CHAPTER –IX SOCIAL RESPONSIBILITIES OF BUSINESS

Dr.R. Rajavardhini,  
*Department of Commerce,*  
*Ponnaiyah Ramajayam Institute of Science & Technology(PRIST)*

### **Definition of Social Responsibility**

“Social responsibilities refer to the businessman’s decisions and actions taken to reasons at least partially beyond the firm’s direct economic or technical interest.”

### **Features of Social Responsibility**

Based on this definition, following features of SR can be identified:

1. The SR contains three types of behaviour- positive, neutral and negative. The negative and neutral aspects of behaviour areas important as positive.
2. Every person in the society has a social obligation to fulfil. However, the emphasis is on social responsibility of management as a group because it is in a position to use the resources of the society in the way it likes. Therefore, it must be conscious about its SR.
3. SR involves fulfilling obligations to various parties concerned with the functioning of an organisation. Some of these parties are concerned directly. Others may be concerned indirectly.
4. The standards fixed for fulfilling obligations to various parties are to be decided according to social norms and expectations. Therefore, these obligations may vary from society to society.

### **Scope of Social Responsibility**

Social responsibility and business ethics while working alongside each other tell what a business organisation should do. The issue of responsibilities of business towards society merits consideration in all phases of business growth.

The scope of social responsibility is comprehensive and can be considered in terms of diverse factors. Some people cogitate social responsibility in terms of employees, customers and shareholders.

Thus, the business organisations, depending on their nature and size, can extend social responsiveness to the problems of the local community and the nation at large.

### **Social Responsibility of Managers**

Social responsibility (SR) of managers predominantly in business organisations has, of late, been one of the most spoken of.. Traditionally the fundamental objective of a business has been defined in terms of profit maximisation. The first break came in the 1930s when the view was radical and accepted that managers of large companies must make decisions, which maintain an equitable balance among the shareholders, employees, customers, suppliers and public. Managers took painstaking measures to meet the interests.. Such a view was later developed as the social responsibility.

The phrase social responsibility is widely used in the literature of sociology, anthropology, economics, politics and business management. However, conceptually as well as in practice also, this has been a volatile, vague and confused area. Conceptually, there is confusion as to the exact meaning of SR is and how it works in practicality. . From a practical point of view, the response from business has gone on providing a spectrum ranging from mere verbal sympathy to multi- lakh rupees concrete programmes in our country.



**CHAPTER –X STRATEGIC MANAGEMENT**  
Dr.G. Karthiga,  
*Department of Commerce,*  
*Ponnaiyah Ramajayam Institute of Science & Technology(PRIST)*

**Definition:** "Strategic management is the process of managing the pursuit of organisational mission while managing the relationship of the organisation to its environment." (James M. Higgins)

### **Elements of Strategic Management**

Strategic management, as minimum, includes strategic planning and strategic control. Strategic planning describes the periodic activities undertaken by organisations to cope with changes in their external environments (Lester A. Digman).

Strategic planning entails formulating strategies from which overall plans for implementing the strategy are developed. Further, strategic planning includes conveying and appraising alternative strategies, choosing a strategy and developing meticulous plans for putting the strategy into practice. Strategic control consists of ensuring that the chosen strategy is being implemented properly and that it is producing the desired results.

Based on Robert Anthony's framework, three types of planning and control are required by organisations:

- **Strategic Planning and Control:** This is the process of deciding on changes in organisational objectives, in the resources to be used in attaining these objectives, in policies governing the acquisition and use of these resources and in the means (strategies) of attaining the objectives. Strategic planning and control involve actions that change the character or direction of the organisation.
- **Management Planning and Control:** This entails the process of ensuring that resources are acquired and used resourcefully in the completion of the organisation's goals. Management planning and control is approved within the framework established by strategic planning and is analogous to operating control.
- **Technical Planning and Control:** This is the process of guaranteeing an efficient acquisition and utilisation of resources, with regards to activities for which the optimum relationship between outputs and resources can be accurately estimated (e.g. financial, accounting and quality controls).

### **Scope of Strategic Management**

J. Constable has defined the area addressed by strategic management as "the management processes and decisions which determine the long-term structure and activities of the organisation." This definition incorporates five key themes:

- **Management process:** Management processes relate to how strategies are created and changed.
- **Management decisions:** The decisions must relate clearly to a solution of perceived problems (how to avoid a threat, how to capitalize on an opportunity).
- **Time scales:** The strategic time horizon is long. However, for a company in real trouble, it can be very short.
- **Structure of the organisation:** An organisation is appropriately managed by workforce within a structure. The decisions resulting from the way that managers work together within the structure can result in strategic change.
- **Activities of the organisation:** This is a potentially limitless area of study and we normally shall centre upon all activities which affect the organisation.

These all five themes are fundamental to the study of the strategic management field.



# ELECTRON DEVICES AND CIRCUITS

Edited By

**R.ELANGOVAN**



978-93-6255-861-9

**ELECTRON DEVICES AND CIRCUITS**

Copyright © 2018 by Mr.R.Elangovan

All rights reserved. No part of this book may be reproduced or transmitted in any form or by any means without written permission from the author.

ISBN: 978-93-6255-861-9

Publisher: Ponnaiyah Ramajayam Institute of Science and Technology (PRIST)

Date of Publication : 22.12.18

## TABLE OF CONTENTS

<b>Introduction</b> .....	<b>10</b>
<b>CHAPTER 1</b> - Characteristics of PN Junction and Zener Diode .....	<b>20</b>
Mr.Dr.S.A.Ahamed Ibrahim	
<b>CHAPTER 2</b> – Characteristics And Its Applications Of Op Amp.....	<b>32</b>
Mr.J.Vivek Raja	
<b>CHAPTER 3</b> - Transistors and thyristors .....	<b>85</b>
Mr.D.Hariharan	
<b>CHAPTER 4</b> - Multi stage amplifiers .....	<b>96</b>
Mr.B.Arunpandiyan	
<b>CHAPTER 5</b> – Feedback amplifiers and oscillators .....	<b>118</b>
Mrs.R.Prasannadevi	
<b>CHAPTER 6</b> – Rectifiers .....	<b>143</b>
Mr.Dr.S.A.Ahamed Ibrahim	
<b>CHAPTER 7</b> – Field-Effect Transistor .....	<b>174</b>
Mr.J.Vivek Raja	
<b>CHAPTER 8</b> – JFET & CMOS.....	<b>181</b>
Mr.D.Hariharan	
<b>CHAPTER 9</b> – MOSFET .....	<b>198</b>
Mr.B.Arunpandiyan	
<b>CHAPTER 10</b> – SCR & TRIAC .....	<b>206</b>
Mrs.R.Prasannadevi	
<b>REFERENCES</b> .....	<b>211</b>

# CHAPTER 1

## Characteristics of PN Junction and Zener Diode

Mr.Dr.S.A.Ahamed Ibrahim

### PN Junction Diode

#### Characteristics:

##### 1. Basic Structure:

- **Junction:** Consists of a P-type (positive) and an N-type (negative) semiconductor material joined together, forming a junction.
- **Depletion Region:** At the junction, a depletion region is formed where mobile charge carriers recombine, creating an area devoid of charge carriers.

##### 2. Forward Bias:

- **Current Flow:** When forward-biased (positive voltage applied to the P-side and negative to the N-side), the depletion region narrows, allowing current to flow through the diode.
- **Threshold Voltage:** Requires a minimum forward voltage (typically around 0.7V for silicon diodes) to overcome the built-in potential barrier and allow current to flow.

##### 3. Reverse Bias:

- **Current Flow:** When reverse-biased (positive voltage applied to the N-side and negative to the P-side), the depletion region widens, preventing current flow. Only a small leakage current (reverse saturation current) flows.
- **Breakdown:** If the reverse voltage exceeds a certain threshold (reverse breakdown voltage), the diode may undergo breakdown, allowing a large current to flow.

### Zener Diode

#### Characteristics:

##### 1. Basic Structure:

- **Junction:** Similar to a PN junction diode but designed to operate in the reverse breakdown region.
- **Design:** Specifically designed to exploit the Zener breakdown or avalanche breakdown phenomenon.

##### 2. Zener Breakdown:

- **Reverse Bias:** Operates in reverse bias and is designed to allow current flow once the reverse voltage reaches a specific breakdown voltage (Zener knee voltage).
- **Voltage Regulation:** The Zener breakdown voltage remains nearly constant over a range of currents, making it useful for voltage regulation.

##### 3. Forward Bias:

- **Current Flow:** Similar to a regular diode, it requires a forward voltage (about 0.7V for silicon Zener diodes) to conduct in forward bias.

##### 4. Reverse Breakdown Characteristics:

- **Zener Effect:** For breakdown voltages below 5V, Zener effect dominates, characterized by a sharp increase in current.
- **Avalanche Effect:** For breakdown voltages above 5V, avalanche effect occurs, where high-energy electrons impact and free more charge carriers, causing breakdown.

## CHAPTER 2

### Characteristics and Its Applications of Op Amp

Mr.J.Vivek Raja

#### Characteristics of Op-Amps

##### Ideal Characteristics:

- **Infinite Open-Loop Gain:** An ideal op-amp has an infinite voltage gain when there is no feedback applied.
- **Infinite Input Impedance:** The input impedance is infinite, meaning the op-amp draws no current from the signal source.
- **Zero Output Impedance:** The output impedance is zero, allowing the op-amp to drive any load without affecting its output voltage.
- **Infinite Bandwidth:** An ideal op-amp can amplify signals of any frequency without attenuation.
- **Zero Offset Voltage:** There is no voltage difference between the inverting and non-inverting inputs when the output is zero.
- **Infinite Common-Mode Rejection Ratio (CMRR):** An ideal op-amp rejects all common-mode signals, amplifying only the difference between its inputs.

##### Practical Characteristics:

- **High Open-Loop Gain:** Real op-amps have high but finite open-loop gain, which decreases with frequency.
- **High Input Impedance:** Real op-amps have very high input impedance but are not infinite. This minimizes the loading effect on the preceding stage.
- **Low Output Impedance:** Real op-amps have low output impedance, which is still sufficiently low for most applications.
- **Finite Bandwidth:** Real op-amps have a limited bandwidth, often characterized by a gain-bandwidth product (GBP).
- **Offset Voltage:** There is a small voltage difference between the inputs even when the output is zero.
- **Common-Mode Rejection Ratio (CMRR):** Real op-amps have high CMRR, but not infinite. They are designed to minimize the effect of common-mode signals.

##### Parameters:

- **Gain-Bandwidth Product (GBP):** The product of the gain and bandwidth of the op-amp is constant. It defines the frequency at which the gain of the op-amp drops to unity.
- **Slew Rate:** The maximum rate at which the output voltage can change. It determines how fast the op-amp can respond to rapid changes in the input signal.
- **Input Offset Voltage:** The small voltage required between the input terminals to make the output zero. It is an inherent imperfection in practical op-amps.

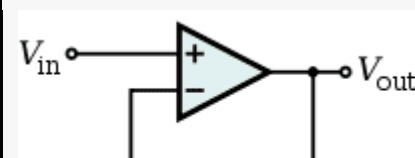
OPERATIONAL APPLICATIONS		AMPLIFIER
Comparator		
Voltage Follower		

# CHAPTER 3

## Transistors and Thyristors

Mr.D.Hariharan

### Transistors

#### Overview:

Transistors are semiconductor devices used to amplify or switch electronic signals. They are fundamental building blocks in modern electronic circuits and can be found in virtually every electronic device.

#### Types:

##### Bipolar Junction Transistor (BJT):

- **Structure:** Consists of three layers of semiconductor material arranged as either NPN or PNP.
- **Operation:** Uses both electron and hole charge carriers. The current flowing between the collector and emitter is controlled by the base current.

##### Field-Effect Transistor (FET):

- **Structure:** Uses an electric field to control the flow of current. The main types are:
- **Junction FET (JFET):** Has a channel controlled by a gate voltage.
- **Metal-Oxide-Semiconductor FET (MOSFET):** Has a gate isolated from the channel by a thin oxide layer. MOSFETs can be further classified into N-channel and P-channel types.

#### Characteristics:

##### Amplification:

- **BJT:** Amplifies current. The current gain ( $\beta$ ) is a key parameter.
- **FET:** Amplifies voltage. The transconductance ( $g_m$ ) is a key parameter.

##### Switching:

- **BJT:** Fast switching times, used in high-speed digital circuits.
- **FET:** Generally higher input impedance, used in analog signal processing and high-impedance applications.

##### Input and Output:

- **BJT:** Current-controlled device with low input impedance.
- **FET:** Voltage-controlled device with high input impedance.

##### Power Dissipation:

- **BJT:** Higher power dissipation due to higher base current.
- **FET:** Lower power dissipation due to lower gate current.

### Thyristors

#### Overview:

Thyristors are semiconductor devices used primarily for switching and controlling high-power AC and DC signals. They are also known as silicon-controlled rectifiers (SCRs).

#### Types:

##### Silicon-Controlled Rectifier (SCR):

- **Structure:** Consists of four layers (PNPN) and four junctions.
- **Operation:** Can be turned on by applying a gate current and remains on even after the gate current is removed until the current through it drops below a certain level.

##### Triac:

- **Structure:** A type of thyristor designed to control AC power. It allows current to flow in both directions.
- **Operation:** Can be triggered by a gate signal to control the AC power.

# CHAPTER 4

## Multi stage amplifiers

Mr.B.Arunpandiyam

### Overview of Multi-Stage Amplifiers

#### 1. Purpose:

- **Gain Enhancement:** To achieve higher total gain than a single stage can provide.
- **Impedance Matching:** To match impedance between different stages or between the amplifier and its load.
- **Signal Conditioning:** To improve signal quality by providing better noise performance, bandwidth control, and linearity.

#### 2. Configuration:

- **Cascading:** Stages are connected in series, with the output of one stage feeding into the input of the next stage.
- **Coupling:** Stages are coupled using coupling capacitors (in AC coupling) or direct connections (in DC coupling) to transfer the signal while isolating DC components.

### Types of Stages

#### Common-Emitter (CE) Stage:

- **Configuration:** Typically used in BJTs.
- **Characteristics:** Provides good voltage gain and is commonly used as the first stage in a multi-stage amplifier.
- **Applications:** Suitable for high-gain and moderate-frequency applications.

#### Common-Collector (CC) Stage:

- **Configuration:** Also known as an emitter follower, often used in BJTs.
- **Characteristics:** Provides impedance matching with unity voltage gain and is used to drive low-impedance loads.
- **Applications:** Used for impedance buffering between stages.

#### Common-Base (CB) Stage:

- **Configuration:** Less common in BJTs, used in high-frequency applications.
- **Characteristics:** Provides high-frequency gain and has low input impedance.
- **Applications:** Used in RF amplifiers and high-frequency circuits.

#### Source Follower (Common-Source):

- **Configuration:** Used in FETs, similar to the CC stage but for FETs.
- **Characteristics:** Provides high input impedance and is used for impedance matching.

#### Common-Drain (CD) Stage:

- **Configuration:** Also known as a source follower in MOSFETs.
- **Characteristics:** Provides impedance matching with unity gain.

#### Common-Gate (CG) Stage:

- **Configuration:** Used in FETs, less common than other stages.
- **Characteristics:** Provides high-frequency gain and has high output impedance.

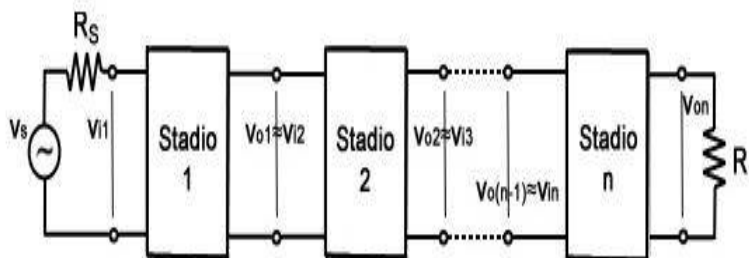



# CHAPTER 5

## Feedback amplifiers and oscillators

Mrs.R.Prasannadevi

### Feedback Amplifiers

**Definition:** A feedback amplifier uses a portion of its output signal to influence its input signal. This feedback can be positive or negative.

#### Types of Feedback:

##### 1. Negative Feedback:

- **Purpose:** Reduces distortion, improves stability, and increases bandwidth.
- **How it Works:** The output signal is fed back in such a way that it subtracts from the input signal, effectively reducing the overall gain.
- **Example:** Inverting amplifier, where a resistor network is used to provide feedback to the inverting input.

##### 2. Positive Feedback:

- **Purpose:** Can increase gain and produce oscillations.
- **How it Works:** The output signal is fed back in such a way that it adds to the input signal, increasing the overall gain.
- **Example:** In a regenerative receiver, where positive feedback helps amplify weak signals.

### Oscillators

**Definition:** An oscillator is a circuit that generates a continuous waveform (such as sine, square, or triangle waves) without needing an external input signal. It uses positive feedback to maintain oscillations.

#### Types of Oscillators:

##### 1. LC Oscillators:

- **Components:** Use inductors (L) and capacitors (C) to determine the frequency.
- **Example:** Colpitts oscillator, Hartley oscillator.
- **Frequency Determination:** The frequency of oscillation is determined by the LC network.

##### 2. RC Oscillators:

- **Components:** Use resistors (R) and capacitors (C).
- **Example:** Phase-shift oscillator, Wien bridge oscillator.
- **Frequency Determination:** The frequency of oscillation is determined by the RC network.

##### 3. Crystal Oscillators:

- **Components:** Use a quartz crystal to stabilize the frequency.
- **Example:** Used in wristwatches and clocks.
- **Frequency Determination:** The crystal provides a very stable and precise frequency.

##### 4. Relaxation Oscillators:

- **Components:** Use components like resistors and capacitors to create a sawtooth or triangular waveform.
- **Example:** 555 timer IC in astable mode.
- **Frequency Determination:** The frequency is set by the timing components.

# CHAPTER 6

## Rectifiers

Mr.Dr.S.A.Ahamed Ibrahim

Rectifiers are essential components in electrical engineering that convert alternating current (AC) into direct current (DC). Here's an overview of how they work and their various types:

### Basic Function:

- **AC to DC Conversion:** Rectifiers are used to change the direction of current flow, so it is unidirectional, which is necessary for powering DC devices or for providing a stable DC voltage from an AC supply.

### Types of Rectifiers:

#### Half-Wave Rectifier:

- **Operation:** Uses a single diode to convert AC to DC. The diode only allows one half of the AC cycle to pass through, blocking the other half.
- **Output:** Produces a pulsating DC output with a frequency equal to the AC supply frequency.
- **Efficiency:** Simple and inexpensive but has low efficiency and high ripple (variation in the DC output).

#### Full-Wave Rectifier:

- **Operation:** Uses either two diodes with a center-tap transformer or a bridge rectifier with four diodes to convert the entire AC waveform into DC.
- **Output:** Provides a smoother DC output compared to a half-wave rectifier, with a frequency that is twice the AC supply frequency.
- **Types:**
  - **Center-Tap Transformer:** Requires a center-tap transformer and two diodes.
  - **Bridge Rectifier:** Uses four diodes arranged in a bridge configuration, allowing it to work with both center-tap and non-center-tap transformers.

#### Bridge Rectifier:

- **Operation:** Employs four diodes arranged in a bridge configuration to convert AC to DC. This configuration allows for a full-wave rectification without needing a center-tap transformer.
- **Advantages:** More efficient than a half-wave rectifier and doesn't require a center-tap transformer, making it more versatile.

#### Full-Wave Center-Tap Rectifier:

- **Operation:** Uses two diodes and a center-tap transformer to convert AC to DC.
- **Advantages:** Provides a smoother DC output compared to half-wave rectifiers.

### Key Characteristics:

#### Ripple:

- **Definition:** The AC component remaining in the DC output after rectification. Lower ripple indicates a smoother DC output.
- **Mitigation:** Ripple can be reduced using filters like capacitors or inductors.

#### Efficiency:

- **Definition:** The effectiveness of the rectifier in converting AC to DC. Higher efficiency means less energy is lost during conversion.

#### Peak Inverse Voltage (PIV):

- **Definition:** The maximum voltage a diode can withstand in the reverse direction without breaking down. It's an important parameter to consider when choosing diodes for rectification.

# CHAPTER 7

## Field-Effect Transistor

Mr.J.Vivek Raja

A Field-Effect Transistor (FET) is a type of transistor that controls the flow of electrical current using an electric field. Unlike bipolar junction transistors (BJTs) which use both electron and hole charge carriers, FETs use only one type of charge carrier, making them highly efficient and suitable for various applications. Here's an overview of FETs, including their types, operation, and applications:

### Basic Operation:

### Structure:

- **Three Terminals:** The FET has three terminals: Gate (G), Drain (D), and Source (S).
- **Channel:** The region between the drain and source where current flows is called the channel. The conductivity of this channel is controlled by the voltage applied to the gate.

### Control Mechanism:

- **Electric Field:** The gate voltage creates an electric field that controls the flow of current between the drain and source. This field modulates the channel's conductivity, hence controlling the current flow.

### Types of FETs:

#### Junction FET (JFET):

- **Operation:** The gate is reverse-biased with respect to the source, which controls the channel's width and thus the current flow.
- **Types:**
  - **n-channel JFET:** Uses an n-type semiconductor for the channel.
  - **p-channel JFET:** Uses a p-type semiconductor for the channel.

#### Metal-Oxide-Semiconductor FET (MOSFET):

- **Operation:** Uses an insulating layer (usually silicon dioxide) between the gate and the channel. The gate voltage creates an electric field across the insulator, affecting the channel's conductivity.
- **Types:**
  - **Enhancement-mode MOSFET:** Normally off when the gate-source voltage ( $V_{GS}$ ) is zero. A positive (n-channel) or negative (p-channel) gate voltage enhances the channel and allows current to flow.
  - **Depletion-mode MOSFET:** Normally on when  $V_{GS}$  is zero. A gate voltage is used to deplete the channel and reduce current flow.

#### Insulated-Gate FET (IGFET):

- This term is often used interchangeably with MOSFET, emphasizing the gate insulation.

# CHAPTER 8

## JFET & CMOS

Mr.D.Hariharan

Junction FET (JFET) and Complementary Metal-Oxide-Semiconductor (CMOS) technologies are both types of field-effect transistors (FETs) but serve different purposes and have different characteristics. Here's a detailed look at each:

### Junction Field-Effect Transistor (JFET)

#### Overview:

- **Structure:** A JFET consists of a semiconductor channel (n-type or p-type) and a gate junction that controls the flow of current through the channel.
- **Operation:** The gate-source voltage ( $V_{GS}$ ) controls the width of the channel by varying the electric field, which in turn regulates the current between the drain and source.

#### Types:

- **n-channel JFET:** Uses an n-type semiconductor for the channel, where the majority carriers are electrons.
- **p-channel JFET:** Uses a p-type semiconductor for the channel, where the majority carriers are holes.

#### Characteristics:

- **High Input Impedance:** JFETs have high input impedance, making them suitable for use as input stages in amplifiers.
- **Pinch-Off Voltage:** The voltage at which the channel is completely pinched off and current flow stops.
- **Low Noise:** Due to their high input impedance, JFETs are used in low-noise applications.
- **Voltage-Controlled:** The gate is reverse-biased to control the channel conductivity.

#### Applications:

- **Amplifiers:** Used in the front-end stages of amplifiers due to their high input impedance.
- **Impedance Matching:** Ideal for impedance matching in various circuits.



## CHAPTER 9

### MOSFET

Mr. B. Arunpandiyam

A Metal-Oxide-Semiconductor Field-Effect Transistor (MOSFET) is a type of field-effect transistor that is widely used in electronic devices due to its high efficiency and versatility. Here's a detailed look at MOSFETs, including their operation, types, characteristics, and applications:

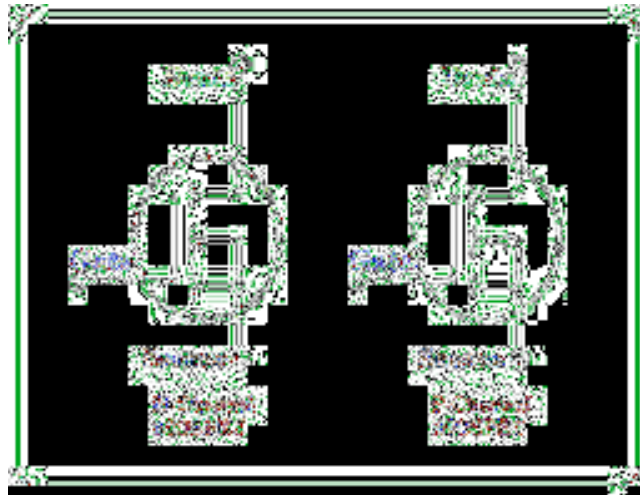

#### Basic Structure and Operation:

##### Structure:

- **Three Terminals:**
  - **Gate (G):** Controls the transistor's conductivity.
  - **Drain (D):** The terminal through which current exits the transistor.
  - **Source (S):** The terminal through which current enters the transistor.
- **Channel:** The region between the drain and source through which current flows. The conductivity of this channel is modulated by the voltage applied to the gate.
- **Gate Oxide:** A thin insulating layer (usually silicon dioxide) separates the gate from the channel.

##### Operation:

- **Gate Voltage Control:** The gate voltage ( $V_{GS}$ ) creates an electric field that modulates the channel's conductivity between the drain and source. When the gate voltage exceeds a certain threshold, the channel forms, allowing current to flow from the drain to the source.

##### Types of MOSFETs:

##### Enhancement-mode MOSFET:

- **n-channel MOSFET:** Normally off when  $V_{GS} = 0$ . A positive voltage applied to the gate creates an n-type channel between the drain and source, allowing current to flow.
- **p-channel MOSFET:** Normally off when  $V_{GS} = 0$ . A negative voltage applied to the gate creates a p-type channel, allowing current to flow.

## CHAPTER 10

### SCR & TRIAC

Mrs. R. Prasannadevi

**Silicon Controlled Rectifiers (SCRs)** and **Triacs** are both types of semiconductor devices used in power control applications. They share similarities but have distinct functions and characteristics. Here's a detailed look at each:

#### Silicon Controlled Rectifier (SCR)

##### \*\*1. \*\* Overview:

- **Structure:** An SCR is a four-layer, three-junction semiconductor device with four terminals: Anode (A), Cathode (K), Gate (G), and a junction that divides the structure into three regions (P-N-P-N).
- **Operation:** It can be turned on by applying a small voltage to the gate terminal (G), which allows a larger current to flow between the anode and cathode. Once turned on, the SCR remains on even if the gate voltage is removed, until the current through it drops below a certain level (known as the holding current).

##### \*\*2. \*\* Characteristics:

- **Unidirectional:** SCRs conduct current in one direction (from anode to cathode) when turned on.
- **Latching Device:** Once triggered on, it stays on until the current drops below the holding current.
- **Gate Control:** The gate voltage controls the SCR's turning-on process, but it cannot turn it off; turning it off requires reducing the current through the SCR.
- **Triggering:** Can be triggered by applying a small gate current or voltage.

##### \*\*3. \*\* Applications:

- **Phase Control:** Used in light dimmers, motor speed controls, and temperature controllers where phase-angle control of AC power is needed.
- **Switching:** Employed in high-power switching applications where precise control of the current is required.
- **Rectifiers:** Used in rectifier circuits to control the output voltage and current.

#### Triac

##### \*\*1. \*\* Overview:

- **Structure:** A Triac (Triode for Alternating Current) is a three-terminal semiconductor device with a structure similar to an SCR but designed for bidirectional operation. The terminals are Gate (G), Main Terminal 1 (MT1), and Main Terminal 2 (MT2).
- **Operation:** It can conduct current in both directions (from MT1 to MT2 and vice versa) when triggered by a gate signal. The Triac remains conductive until the current flowing through it drops below a certain level, even if the gate signal is removed.

##### \*\*2. \*\* Characteristics:

- **Bidirectional:** Triacs can conduct in both directions, making them suitable for AC power control.
- **Gate Control:** The gate terminal can be used to trigger the Triac on, and its state can be controlled to turn it off indirectly by reducing the current below the holding current.
- **Triggering:** Can be triggered by applying a gate voltage or current; it can be turned on during both the positive and negative halves of the AC cycle.

##### \*\*3. \*\* Applications:

- **Phase Control:** Widely used in dimmers for lighting, fan speed controls, and motor speed controls where alternating current needs to be regulated.
- **Motor Control:** Employed in controlling AC motors in various appliances and industrial machinery.
- **Temperature Control:** Used in temperature controllers where precise regulation of AC power is needed.

# **ELECTRIC CIRCUITS LAB**

**EDITED BY  
M.R.GEETHA**



**978-93-6255-973-9**

Electric circuits lab  
Copyright © 2018 by Mrs. M.R.Geetha

All rights reserved. No part of this book may be reproduced or transmitted in any form or by any means without written permission from the author.

ISBN: 978-93-6255-973-9

Publisher: Ponnaiyah Ramajayam Institute of Science and Technology (PRIST)  
Date of Publication : 18.11.18



## TABLE OF CONTENTS

<b>Introduction</b>	-	<b>04</b>
<b>CHAPTER 1</b> - Verification of series and parallel circuits using KVL and KCL Mrs. M.R. Geetha	-	<b>10</b>
<b>CHAPTER 2</b> - Verification of series and parallel circuits using Thevinins theorem Mrs. M.R.Geetha	-	<b>18</b>
<b>CHAPTER 3</b> - Verification of series and parallel circuits using Norton's theorem Mrs. M.R.Geetha	-	<b>25</b>
<b>CHAPTER 4</b> - Verification of series and parallel circuits using superposition theorem Mrs. M.R.Geetha	-	<b>34</b>
<b>CHAPTER 5</b> - Verification of series and parallel circuits using Maximum Power Transfer Theorem Mrs. M.R.Geetha	-	<b>52</b>
<b>CHAPTER 6</b> - Simulation and experimental verification of Maximum Power transfer theorem.- Mrs. M.R.Geetha	-	<b>34</b>
<b>CHAPTER 7</b> - Simulation and Experimental validation of R-C,R-L and RLC electric circuit transients Mrs. M.R.Geetha	-	<b>41</b>
<b>CHAPTER 8</b> – Simulation and Experimental validation of frequency response of RLC electric circuit. Mrs. M.R.Geetha	-	<b>46</b>
<b>CHAPTER 9</b> - Design and implementation of series and parallel resonance circuit. Mrs. M.R.Geetha	-	<b>52</b>
<b>CHAPTER 10</b> - Simulation and experimental verification of three phase balanced and unbalanced star, delta networks circuit (Power and Power factor calculations). Mrs. M.R.Geetha	-	<b>60</b>
<b>REFERENCES</b>	-	<b>65</b>

# CHAPTER 1

## Verification of series and parallel circuits using KVL and KCL

Mrs. M.R. Geetha

**AIM:**

To Verify KCL & KVL from the given circuit.

**APPARATUS REQUIRED:**

S.NO.	NameoftheApparatus	Range	Quantity
1	Bread Board	-	1
2	Resistor	1KΩ	3
3	Ammeter	0-25mA	3
4	Voltmeter	0-30V	2
5	RPS	0-30V	1

**THEORY:**

Kirchhoff's Voltage Law (KVL) states that the algebraic sum of all branch voltages around any closed path in a circuit is always zero at all instants of time. In the figure 1.1, if KVL is applied then the equation is  $V_s = V_1 + V_2 + V_3$

Kirchhoff's Current Law (KCL) states that the sum of the currents entering into any node/point/junction is equal to the sum of the currents leaving that node/point/junction. In the figure 1.2, if KCL is applied then the equation is  $I_T = I_1 + I_2 + I_3$

**CIRCUIT DIAGRAM:**

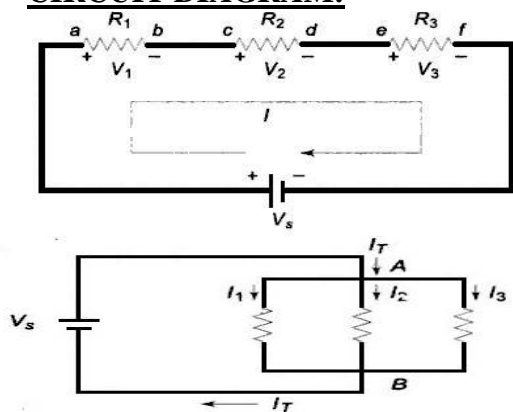

**TABULATION:**

Vin (v)	I <sub>1</sub> (mA)		I <sub>2</sub> (mA)		I <sub>L</sub> =I <sub>1</sub> +I <sub>2</sub> (mA)	
	Theoretical	Practical	Theoretical	Practical	Theoretical	Practical

**RESULT:**

Thus find KCL & KVL from the given circuit.

## CHAPTER 2

### Verification of series and parallel circuits using Thevinins theorem

Mrs. M.R. Geetha

**AIM:**

To find the Thevenin's equivalent circuit from the given circuit.

**APPARATUS REQUIRED:**

S.NO.	Name of the Apparatus	Range	Quantity
1	Bread Board	-	1
2	Resistor	1KΩ	3
3	Resistor	2.2 KΩ	2
4	Resistor	4.7 KΩ	1
5	Ammeter	0-100mA	1
6	Voltmeter	0-30V	1
7	RPS	0-30V	1

**CIRCUIT DIAGRAM:**

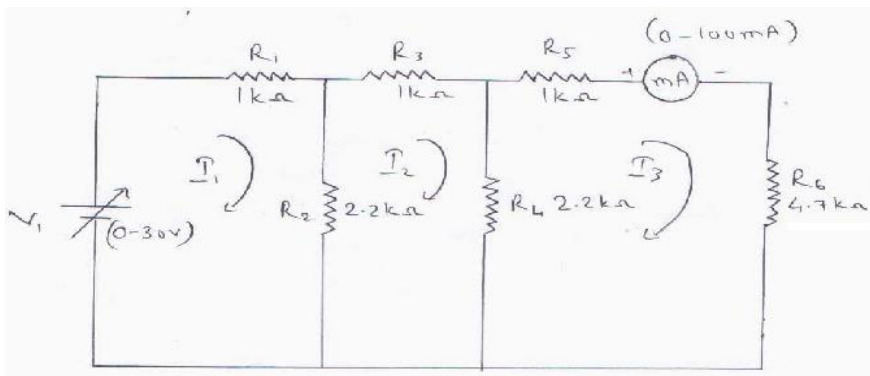

**TABULATION:**

Table 1 (for  $I_3$  &  $V_{TH}$  or  $V_{AB}$ ):

V1 (v)	$I_3$ (mA)		$V_{TH}$ (v)	
	Theoretical	Practical	Theoretical	Practical

**RESULT:**

Thus find the Thevenin's equivalent circuit from the given circuit.

## CHAPTER 3

### Verification of series and parallel circuits using Norton's theorem

Mrs. M.R. Geetha

**AIM:**

To find the Norton's equivalent circuit from the given circuit.

**APPARATUS REQUIRED:**

S.NO.	Name of the Apparatus	Range	Quantity
1	Bread Board	-	1
2	Resistor	1KΩ	3
3	Resistor	2.2 KΩ	2
4	Resistor	4.7 KΩ	1
5	Ammeter	0-100mA	1
6	Voltmeter	0-30V	1
7	RPS	0-30V	1

**CIRCUIT DIAGRAM:**

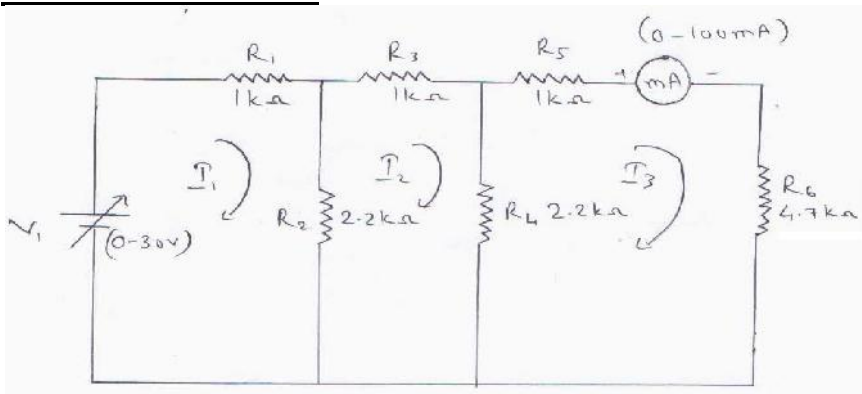

**TABULATION:**

Table 1 (for  $I_3$  &  $I_N$ ):

$V_1$ (V)	$I_3$ (mA)		$I_N$ (mA)	
	Theoretical	Practical	Theoretical	Practical

**RESULT:**

Thus find the Norton's equivalent circuit from the given circuit.

## CHAPTER 4

### Verification of series and parallel circuits using superposition theorem

Mrs. M.R. Geetha

**AIM:**

To find the superposition equivalent circuit from the given circuit.

**APPARATUS REQUIRED:**

S.NO.	Name of the Apparatus	Range	Quantity
1	Bread Board	-	1
2	Resistor	1KΩ	2
3	Resistor	2.2 KΩ	2
4	Ammeter	0-25mA	1
5	Voltmeter	0-30V	1
6	RPS	0-30V	1

**CIRCUIT DIAGRAM:**

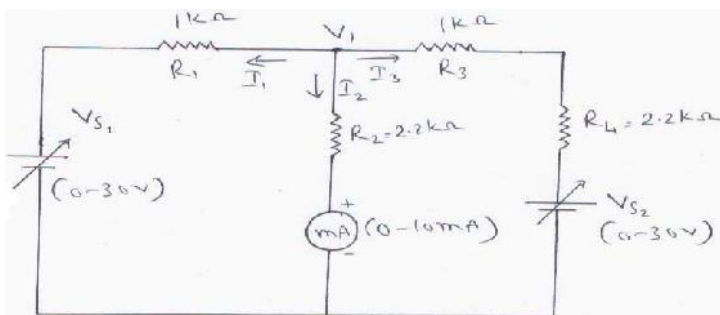

**TABULATION:**

Table 1 (for I<sub>2</sub>):

V <sub>S1</sub> (v)	V <sub>S2</sub> (v)	I <sub>2</sub> (mA)	
		Theoretical	Practical

**NOTE:** All theoretical values can be found by using either mesh analysis or nodal analysis and also using voltage division rule and current division rule where it is applicable.

**RESULT:**

Thus find the superposition equivalent circuit from the given circuit.

## CHAPTER 5

### Verification of series and parallel circuits using Maximum power transfer theorem

Mrs. M.R. Geetha

#### AIM:

To find the Maximum Power Transfer Theorem.

#### APPARATUS REQUIRED:

S.NO.	Name of the Apparatus	Range	Quantity
1	BreadBoard	-	1
2	Resistors	470Ω, 750Ω	1 Each
3	Resistors	560Ω, 330Ω	1 Each
4	Ammeter	0-10mA	1
5	Voltmeter	0-30V	1
6	RPS	0-30V	1
7	DRB	-	1

#### CIRCUIT DIAGRAM:

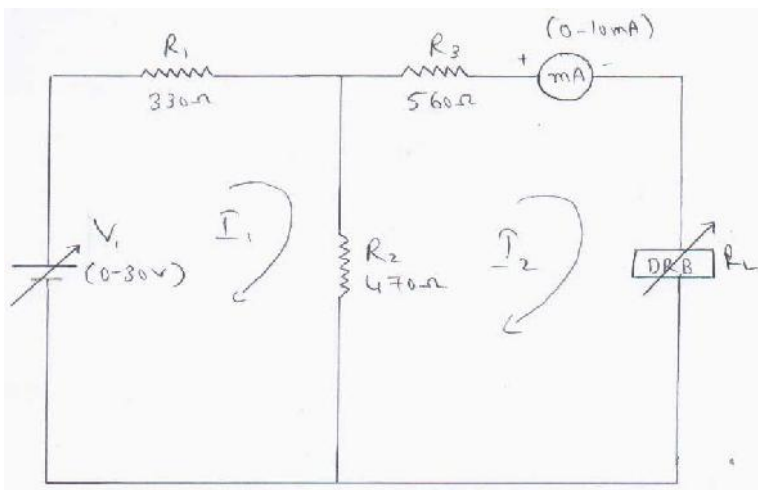

#### TABULATION:

$R_L(\Omega)$	$I_L(\text{mA})$	$P=I_L^2 R_L(\text{mW})$

#### RESULT:

Thus find the Maximum Power Transfer Theorem

## CHAPTER 6

### Simulation and experimental verification of Maximum Power transfer theorem

Mrs. M.R.Geetha

#### AIM:

To verify maximum power transfer theorem.

#### APPARATUS REQUIRED:

S.NO.	NameoftheApparatus	Range	Quantity
1	BreadBoard	-	1
2	Resistors	470 $\Omega$ ,750 $\Omega$	1Each
3	Resistors	560 $\Omega$ ,330 $\Omega$	1Each
4	Ammeter	0-10mA	1
5	Voltmeter	0-30V	1
6	RPS	0-30V	1
7	DRB	-	1

#### SOFTWARE REQUIRED:

Matlab 7.1

#### PROCEDURE:

1. Find the Load current for the minimum position of the Rheostat theoretically.
2. Select the ammeter Range.
3. Give connections as per the circuit diagram.
4. Measure the load current by gradually increasing RL .
5. Enter the readings in the tabular column.
6. Calculate the power delivered in RL.
7. Plot the curve between RL and power.
8. Check whether the power is maximum at a value of load resistance that equals source resistance.
9. Verify the maximum power transfer theorem.

#### RESULT:

Thus the Maximum power transfer theorem was verified.

## CHAPTER 7

### Simulation and Experimental validation of R-C,R-L and RLC electric circuit transients

Mrs. M.R.Geetha

#### AIM:

To find the time constant of series R-C electric circuits

#### APPARATUS REQUIRED:

S.NO.	NameoftheApparatus	Range	Quantity
1	BreadBoard	-	1
2	Resistors	470 $\Omega$ ,750 $\Omega$	1Each
3	Function generator	-	1Each
4	Ammeter	0-10mA	1
5	Voltmeter	0-30V	1
6	RPS	0-30V	1
7	DRB	-	1

#### SOFTWARE REQUIRED:

Matlab 7.1

#### PROCEDURE:

1. Make the connections as per the circuit diagram.
2. Vary the frequency by using function generator.
3. For different frequencies tabulate the value of voltage across the capacitor .
4. Calculate the time period.
5. Plot the graph for time period Vs voltage across the capacitor.

#### TABULATION:

$R_L(\Omega)$	Frequency (Hz)	Time (s)	Voltage across the capacitor VC (v)

#### RESULT:

Thus the transient responses of RC circuit are found practically.



## CHAPTER 8

### Simulation and Experimental validation of frequency response of RLC electric circuit.

Mrs. M.R.Geetha

#### AIM:

To simulate and find the frequency response of RLC electric circuits.

#### APPARATUS REQUIRED:

S.NO.	NameoftheApparatus	Range	Quantity
1	BreadBoard	-	1
2	Resistors	470Ω,750Ω	1Each
3	Decade capacitance box	-	2
4	Ammeter	0-10mA	1
5	Voltmeter	0-30V	1
6	RPS	0-30V	1
7	DRB	-	1

#### SOFTWARE REQUIRED:

Matlab 7.1

#### THEORY:

#### RLC CIRCUIT:

Consider a series RLC circuit as shown. The switch is in open state initially.

There is no charge on condenser and no voltage across it. At instant  $t=0$ , switch is closed.

Immediately after closing a switch, the capacitor acts as a short circuit, so current at the time of switching is high. The voltage across capacitor is zero at  $t=0+$  as capacitor acts as a short circuit, and the current is maximum given by,

$$i = V/R \text{ Amps}$$

#### TABULATION:

$R_L(\Omega)$	Frequency (Hz)	Time (s)	Voltage across the capacitor VC (v)

#### RESULT:

Thus the transient responses of RLC circuit are found practically.

## CHAPTER 9

### Design and implementation of series and parallel resonance circuit.

Mrs. M.R.Geetha

#### AIM:

To plot the current Vs frequencies graph of series resonant circuits and hence measure their bandwidth, resonant frequency and Q factor..

#### APPARATUS REQUIRED:

S.NO.	NameoftheApparatus	Range	Quantity
1	BreadBoard	-	1
2	Resistors	470 $\Omega$ ,750 $\Omega$	1Each
3	Function Generator	-	1
4	Ammeter	0-10mA	1
5	Voltmeter	0-30V	1
6	RPS	0-30V	1
7	Decade Inductance Box	-	2

#### SOFTWARE REQUIRED:

Matlab 7.1

#### THEORY:

A circuit is said to be in resonance when applied voltage V and current I are in phase with each other. Thus at resonance condition, the equivalent complex impedance of the circuit consists of only resistance (R) and hence current is maximum. Since V and I are in phase, the power factor is unity.

#### TABULATION:

$R_L(\Omega)$	Frequency (Hz)	Output Current in mA

#### RESULT:

Thus the current Vs frequency graphs of series resonant circuits were plotted and the bandwidth, resonant frequency and Q factor were measured.

## CHAPTER 10

### Simulation and experimental verification of three phase balanced and unbalanced star, delta networks circuit (Power and Power factor calculations).

Mrs. M.R.Geetha

#### **AIM:**

To simulate and do experiment on three phase balanced and unbalanced star, delta networks circuits and to calculate power and power factor

#### **APPARATUS REQUIRED:**

Three Phase Variable Load,  
Ammeters 0-10 A, MI, 2nos  
Wattmeters 0-5 A, 300V, 2Nos  
Voltmeter 0-300V, MI

#### **SOFTWARE REQUIRED:**

Matlab 7.1

#### **BALANCED THREE- PHASE CIRCUIT:**

Balanced phase voltages are equal in magnitude and are out of phase with each other by  $120^\circ$ . The phase sequence is the time order in which the voltages pass through their respective maximum values. A balanced load is one in which the phase impedances are equal in magnitude and in phase.

#### **POSSIBLE LOAD CONFIGURATIONS:**

#### **Four possible connections between source and load:**

1. Y-Y connection (Y-connected source with a Y-connected load)
2. Y- $\Delta$  connection (Y-connected source with a  $\Delta$ -connected load)
3.  $\Delta$ - $\Delta$  connection
4.  $\Delta$ -Y connection

#### **RESULT:**

Thus the simulation and experiment on three phase balanced and unbalanced star, delta networks circuits were done and the power and power factor are calculated. simulated and verified. .

# **ELECTRICAL MACHINES**

---

Edited by

**DR.B.KUNJITHAPATHAM**



978-93-6255-202-0

ELECTRICAL MACHINES  
Copyright © 2018 by DR.B.KUNJITHAPATHAM

All rights reserved. No part of this book may be reproduced or transmitted in any form or by any means without written permission from the author.

ISBN 978-93-6255-202-0

Publisher: Ponnaiyah Ramajayam Institute of Science and Technology (PRIST)  
Date of Publication : 20.10.18

## TABLE OF CONTENTS

<b>Introduction</b>	-	<b>03</b>
<b>CHAPTER 1 - Dc Generators and its Characteristics</b>	-	<b>17</b>
Mrs. M.R. Geetha		
<b>CHAPTER 2 - Electromechanical Energy Conversion</b>	-	<b>34</b>
Mr.MkNm.Sakthi Nagaraj		
<b>CHAPTER 3 - Transformer and its types</b>	-	<b>65</b>
Mr.J. Vivekraj		
<b>CHAPTER 4 - Induction machines</b>	-	<b>125</b>
Dr.B.Kunjithapatham		
<b>CHAPTER 5 - Comparison And Working Of Autotransformer and Three Phase Transformer</b>	-	<b>175</b>
Mrs.R.Prasanna Devi		
<b>CHAPTER 6 – Stepper Motors</b>	-	<b>185</b>
Mrs. M.R. Geetha		
<b>CHAPTER 7 - synchronous generator</b>	-	<b>205</b>
Mr.MkNm.Sakthi Nagaraj		
<b>CHAPTER 8 - synchronous Motors</b>	-	<b>234</b>
Mr.J. Vivekraj		
<b>CHAPTER 9 – Hybrid Motors</b>	-	<b>242</b>
Dr.B.Kunjithapatham		
<b>CHAPTER 10 – Universal Motors</b>	-	<b>250</b>
Mrs.R.Prasanna Devi		
<b>REFERENCES</b>	-	<b>261</b>

# CHAPTER 1

## Dc Generators and its Characteristics

Mrs. M.R. Geetha

The characteristics of a DC generator encompass a range of performance metrics and relationships, including voltage-current characteristics, efficiency, power output, load characteristics, speed-voltage relationships, field current characteristics, temperature effects, and armature reaction. Understanding these characteristics is crucial for designing, operating, and troubleshooting DC generators to ensure they meet desired performance and operational requirements.

### Voltage-Current Characteristics

#### 1.1. Open-Circuit Characteristic (OCC):

- **Definition:** The relationship between the terminal voltage and the field current when the generator is running with no load (i.e., no external current is drawn).
- **Plot:** A graph of terminal voltage (V) versus field current ( $I_f$ ).
- **Importance:** Helps in understanding how the voltage of the generator changes with variations in the excitation current. Typically, the voltage increases with an increase in field current until it reaches a saturation point.

#### 1.2. Internal Characteristic:

**Definition:** The relationship between the terminal voltage and the load current while accounting for the internal resistance of the generator.

- **Plot:** A graph of terminal voltage (V) versus load current ( $I_L$ ).
- **Importance:** Shows how the voltage decreases with an increase in load current due to the voltage drop across the armature resistance.

#### 1.3. External Characteristic:

- **Definition:** The relationship between the terminal voltage and the load current when considering the effects of both the internal resistance and the load connected to the generator.
- **Plot:** A graph of terminal voltage (V) versus load current ( $I_L$ ) including the effect of the load resistance.
- **Importance:** Provides insight into the generator's performance under actual operating conditions, including the effects of load variations on the terminal voltage.

This is due to excessive demagnetizing effects of the armature reaction.

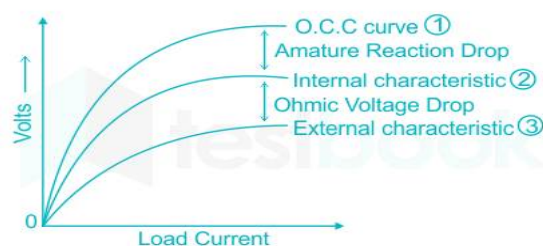

1. O.C.C. curve
2. Internal characteristic curve
3. External characteristic curve

## CHAPTER 2

### Electromechanical Energy Conversion

Mr.S.Govindaswamy

Electromechanical energy conversion involves transforming mechanical energy into electrical energy or vice versa using various devices that operate through either rotary or translatory motion. Here's a detailed explanation of these concepts and their applications:

#### ELECTROMECHANICAL ENERGY CONVERSION

##### 1. Basic Concepts

##### 1.1. Mechanical to Electrical Conversion:

- **Principle:** Mechanical energy is converted into electrical energy through devices like generators, where rotational motion is transformed into electrical power.
- **Example:** A DC generator converts rotational mechanical energy into electrical energy.

##### 1.2. Electrical to Mechanical Conversion:

- **Principle:** Electrical energy is converted into mechanical energy using devices such as motors, where electrical current generates rotary or translatory motion.
- **Example:** An electric motor converts electrical energy into rotational motion.

#### ELECTROMECHANICAL ENERGY CONVERSION

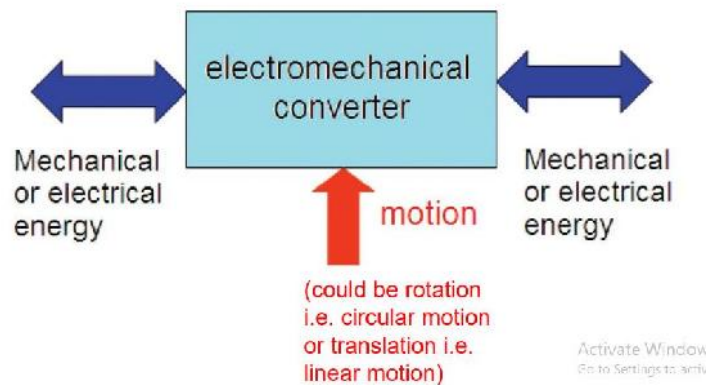

#### APPLICATIONS

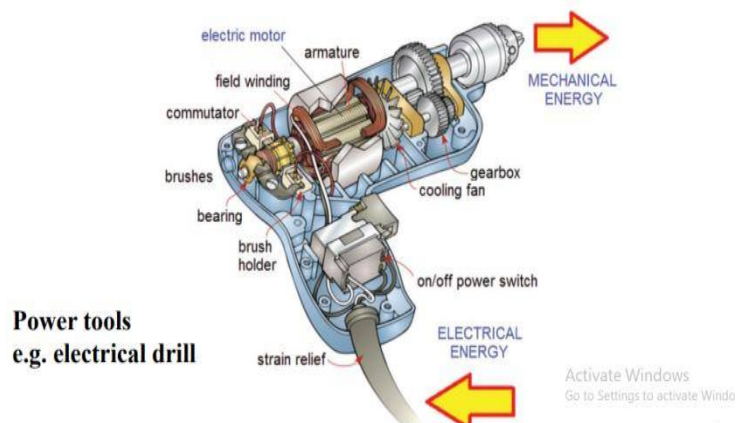



# CHAPTER 3

## Transformer and its types

Mr.J. Vivekraja

### Basics of Transformer Operation

1. **Electromagnetic Induction:** A transformer operates on the principle of electromagnetic induction, specifically mutual induction. It consists of two coils of wire, called the primary and secondary windings, which are wound around a common core. When alternating current (AC) flows through the primary winding, it creates a varying magnetic field in the core.
2. **Mutual Induction:** This varying magnetic field induces a voltage in the secondary winding through the process of mutual induction. The amount of voltage induced depends on the number of turns in the secondary winding relative to the primary winding.

### Transformer Types

Transformers are used in various fields like power generation grid, distribution sector, transmission and electric energy consumption. There are various types of transformers which are classified based on the following factors:

- Working voltage range
- The medium used in the core
- Winding arrangement
- Installation location

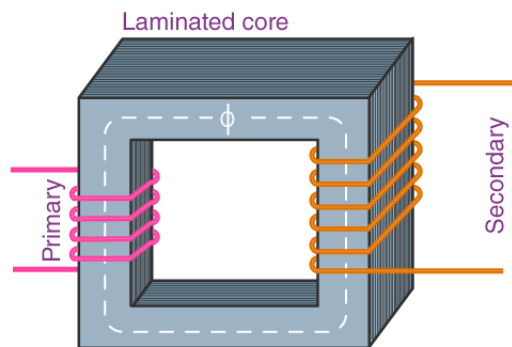

### EMF Equation of Transformer

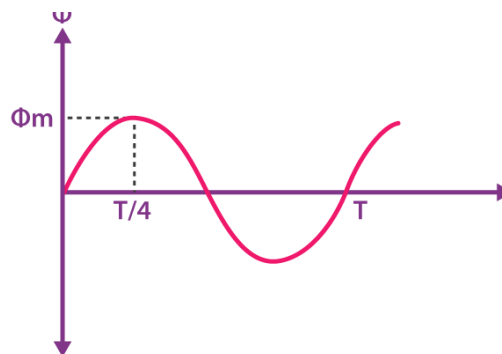

# CHAPTER 4

## Induction machines

Dr.B.Kunjithapatham

### Operation Principle

**Faraday's Law of Electromagnetic Induction:** Induction machines operate based on Faraday's Law, which states that a changing magnetic field induces an electromotive force (EMF) in a conductor. In an induction machine, this principle is applied in the following way:

1. **Stator Windings:** The stator of the induction machine is connected to an AC supply, creating a rotating magnetic field in the stator windings.
2. **Induced Current in Rotor:** This rotating magnetic field induces a current in the rotor windings (or in the rotor bars, in the case of a squirrel-cage rotor). This induced current creates its own magnetic field, which interacts with the stator's rotating field.
3. **Torque Production:** The interaction between the stator's rotating magnetic field and the rotor's induced magnetic field generates torque, causing the rotor to turn.

### Construction

#### 1. Stator:

- **Stator Windings:** The stator is the stationary part of the machine and contains windings connected to the AC power supply. These windings are arranged in such a way that they produce a rotating magnetic field when AC current flows through them.
- **Core:** The stator core is made of laminated steel sheets to reduce eddy current losses and improve efficiency.

#### 2. Rotor:

- **Squirrel-Cage Rotor:** The most common type of rotor, consisting of conductive bars (usually aluminum or copper) short-circuited at both ends by rings. This design is rugged and requires minimal maintenance.
- **Wound Rotor:** Contains three separate windings connected to external resistors or controllers via slip rings. This type allows for better control of the motor's characteristics but is less common than the squirrel-cage type.

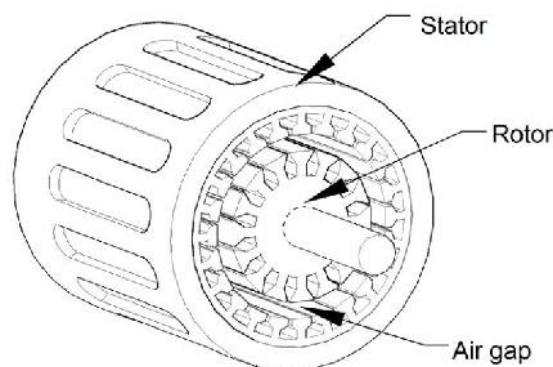

## CHAPTER 5

### Comparison and Working of Autotransformer and Three Phase Transformer

Mrs.R.Prasanna Devi

#### AUTOTRANSFORMER

##### Working Principle:

- **Single-Winding Design:** An autotransformer has a single winding that acts as both the primary and secondary winding. This winding is tapped at different points to provide different voltage levels. The section of the winding between the input and output taps forms the transformer.
- **Voltage Adjustment:** The voltage is adjusted by selecting different points on the single winding. The voltage change is directly proportional to the turns ratio between the tapped points.

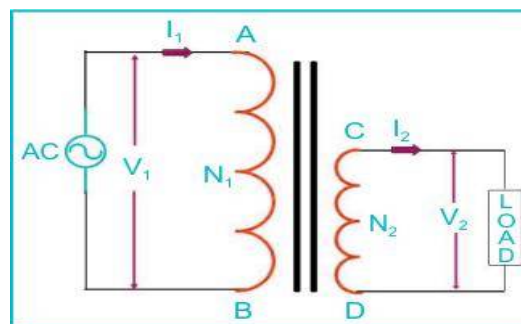

#### Three-Phase Transformer

##### Working Principle:

- **Three Windings:** A three-phase transformer consists of three sets of windings—one for each phase. These windings are arranged on a common core and are used to convert voltages in three-phase AC systems.
- **Balanced Load:** Designed to handle balanced three-phase loads, where each phase carries an equal amount of current.

#### 3- $\phi$ Transformer Construction

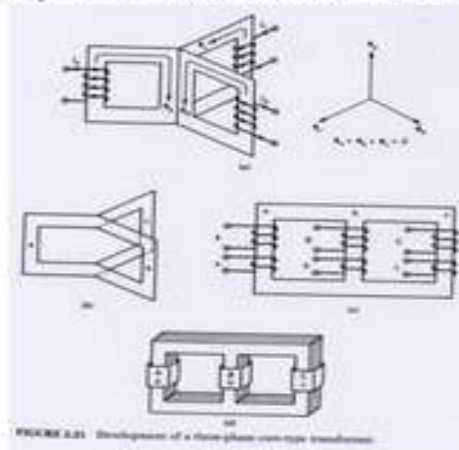

# CHAPTER 6

## Stepper Motors

Mrs. M.R. Geetha

Stepper motors are a type of electric motor that divide a full rotation into a number of discrete steps. They are widely used in applications requiring precise position control and are favored for their ability to provide accurate, repeatable movements without the need for feedback systems. Here's an overview of stepper motors, including their working principles, types, and applications:

### Basic Principles

#### 1. Step-by-Step Rotation:

- Unlike conventional motors, which rotate continuously, stepper motors move in discrete steps. Each step represents a fixed angle of rotation, which allows for precise control of the motor's position.

#### 2. Electromagnetic Operation:

- Stepper motors use electromagnetic fields to control the movement of the rotor. They are equipped with multiple coils organized in phases. By energizing these coils in a specific sequence, the motor moves in steps.

#### 3. Step Angle:

- The step angle is the angle by which the rotor turns when the motor takes one step. It depends on the motor design and is typically between  $0.9^\circ$  and  $1.8^\circ$  per step for common stepper motors. For instance, a motor with a  $1.8^\circ$  step angle has 200 steps per revolution.

### Types of Stepper Motors

#### 1. Permanent Magnet Stepper (PM Stepper):

- **Construction:** Contains a rotor made of permanent magnets and stator windings.
- **Operation:** The rotor aligns with the magnetic field created by the stator coils. These motors are simple and cost-effective but may have lower performance compared to other types.

#### 2. Variable Reluctance Stepper (VR Stepper):

- **Construction:** Uses a rotor with soft iron poles and stator windings.
- **Operation:** The rotor aligns with the magnetic field of the stator windings based on the principle of reluctance. These motors have good stepping precision but are generally noisier and less efficient than PM steppers.

#### 3. Hybrid Stepper Motor:

- **Construction:** Combines features of both permanent magnet and variable reluctance motors.
- **Operation:** Offers improved performance and precision. Hybrid stepper motors are widely used due to their enhanced torque and accuracy. They have a rotor with both permanent magnets and soft iron teeth.

### Operating Modes

#### 1. Full-Step Mode:

- **Operation:** The motor moves in full steps, with each step representing a full step angle. For example, a motor with a  $1.8^\circ$  step angle will move in  $1.8^\circ$  increments per step.

#### 2. Half-Step Mode:

- **Operation:** The motor alternates between full steps and half steps, effectively doubling the resolution. For a motor with a  $1.8^\circ$  step angle, it will move in  $0.9^\circ$  increments in this mode.

# CHAPTER 7

## Synchronous generator

Mr.Mkmm.Sakthi Nagaraj

A synchronous generator, often referred to as an alternator, is a type of electric generator that produces alternating current (AC) by converting mechanical energy into electrical energy through the principle of electromagnetic induction. Here's a detailed overview of synchronous generators, including their operation, construction, and applications:

### Basic Principles

#### 1. Electromagnetic Induction:

- A synchronous generator operates on Faraday's Law of Electromagnetic Induction. It generates electricity by rotating a magnetic field within a set of stationary coils, or stator windings.

#### 2. Synchronous Operation:

- The generator operates synchronously with the grid frequency, meaning the rotor's rotational speed is directly proportional to the frequency of the electrical output. For instance, in a system with a 50 Hz frequency, the rotor speed of a synchronous generator is 1500 RPM (revolutions per minute) for a 4-pole machine, and 1800 RPM for a 6-pole machine in a 60 Hz system.

### Construction

#### 1. Stator:

- The stator is the stationary part of the generator that contains the three-phase windings. These windings are connected to the external load and generate the electrical output when the magnetic field from the rotor induces an electromotive force (EMF) in them.

#### 2. Rotor:

- The rotor is the rotating part of the generator and contains the field windings or permanent magnets. It generates a rotating magnetic field that induces a voltage in the stator windings. The rotor is connected to a mechanical power source, such as a turbine or an engine.

#### 3. Field Winding:

- In a conventional synchronous generator, the rotor's magnetic field is created by the field winding, which is supplied with direct current (DC) through slip rings. In some designs, permanent magnets are used instead of a field winding.

#### 4. Slip Rings and Brushes:

- Slip rings provide a connection between the rotating rotor and the stationary external circuit. Brushes maintain electrical contact with the slip rings to supply DC current to the rotor's field windings.

#### 5. Exciter:

- An exciter provides the necessary DC current to the rotor's field windings. It can be a separate small generator (a conventional exciter) or a static device such as a brushless exciter.

### Operation

#### 1. Magnetic Field Generation:

- When the rotor turns, it creates a rotating magnetic field that cuts through the stator windings. This induces an alternating voltage in the stator windings due to Faraday's Law.

# CHAPTER 8

## Synchronous Motors

Mr.J. Vivekraja

Synchronous motors are a type of electric motor that operates at synchronous speed, meaning their rotor rotates at the same frequency as the rotating magnetic field produced by the stator. Unlike induction motors, which slip (i.e., their rotor speed is slightly less than the synchronous speed), synchronous motors run at a constant speed regardless of the load, as long as the system remains in synchrony. Here's a detailed overview of synchronous motors:

### Basic Principles

#### 1. Synchronous Speed:

- The synchronous speed ( $N_s$ ) of a synchronous motor is determined by the frequency of the AC supply and the number of poles in the motor. It is given by:  $N_s = 120 \times f / p$
- $N_s$  is the synchronous speed in revolutions per minute (RPM).
- $f$  is the supply frequency in hertz (Hz).
- $P$  is the number of poles in the motor.

#### 2. Operation:

- **Magnetic Field:** The stator of a synchronous motor produces a rotating magnetic field when AC current flows through its windings. The rotor, which can be either a permanent magnet or an electromagnet, aligns with this rotating magnetic field.
- **Rotation:** The rotor rotates at the synchronous speed, which is constant and determined by the supply frequency and the number of poles. The motor's rotor is locked in synchrony with the stator's rotating magnetic field.

### Construction

#### 1. Stator:

- The stator is the stationary part of the motor and consists of three-phase windings that are connected to an AC power supply. These windings generate a rotating magnetic field when energized.

#### 2. Rotor:

- The rotor can be of two types:
  - **Salient Pole Rotor:** Contains projecting poles, which are used in low-speed applications. The rotor has a series of poles that protrude and are excited by DC current to create a magnetic field.
  - **Non-Salient Pole Rotor:** Also known as a cylindrical rotor, it is used in high-speed applications and has a smooth cylindrical surface. It also has field windings or permanent magnets to produce the magnetic field.

#### 3. Field Windings:

- In some synchronous motors, the rotor has field windings that are supplied with DC current. These windings create a magnetic field that interacts with the rotating field of the stator.

#### 4. Exciter:

- An exciter supplies the DC current to the rotor's field windings. This can be done using a separate small generator (conventional exciter) or a brushless system.

#### 5. Slip Rings and Brushes:

- For rotors with field windings, slip rings and brushes are used to deliver the DC current to the rotating windings.

# CHAPTER 9

## Hybrid Motors

Dr.B.Kunjithapatham

Hybrid motors combine features of different types of motors to leverage their respective advantages. These motors are designed to enhance performance, efficiency, and control in various applications. The term "hybrid motor" can refer to several different concepts depending on the context. Here's an overview of some common types of hybrid motors:

### 1. Hybrid Electric Vehicles (HEVs) Motors

#### Concept:

- In the context of hybrid electric vehicles (HEVs), hybrid motors typically refer to the combination of an internal combustion engine (ICE) and an electric motor. The aim is to combine the benefits of both power sources to improve fuel efficiency and reduce emissions.

#### Types:

- **Parallel Hybrid:** Both the electric motor and the internal combustion engine can drive the wheels independently or together. This configuration allows for flexible power management and improved efficiency.
- **Series Hybrid:** The internal combustion engine powers a generator that produces electricity for the electric motor, which drives the wheels. The engine operates at its optimal efficiency, while the electric motor provides the primary propulsion.
- **Series-Parallel Hybrid:** Combines elements of both series and parallel configurations, allowing the vehicle to operate in either mode depending on driving conditions.

#### Advantages:

- Improved fuel efficiency and reduced emissions compared to conventional vehicles.
- Flexibility in driving modes and power management.
- Potential for reduced reliance on fossil fuels.

#### Examples:

- Toyota Prius, Honda Insight.

### 2. Hybrid Stepper Motors

#### Concept:

- Hybrid stepper motors combine features of permanent magnet stepper motors and variable reluctance stepper motors. This design aims to improve performance, accuracy, and torque.

#### Types:

- **Permanent Magnet (PM) Hybrid Stepper Motors:** Use permanent magnets in the rotor to enhance torque and stepping accuracy. They combine the advantages of both PM and VR stepper motors.
- **Variable Reluctance (VR) Hybrid Stepper Motors:** Utilize the principle of reluctance and incorporate design features to improve stepping precision and reduce cogging.

#### Advantages:

- Higher torque and improved stepping accuracy.
- Reduced vibration and noise compared to conventional stepper motors.

#### Applications:

- Used in precision motion control applications, such as CNC machines, 3D printers, and robotics.

## CHAPTER 10 Universal Motors

Mrs.R.Prasanna Devi

The universal motor is a fascinating piece of electrical engineering. Here's a breakdown of its key features and operation:

### Basic Structure and Operation:

- **Commutator and Brushes:** A universal motor uses a commutator and brushes to switch the direction of current in the armature windings, which is necessary for it to work with both AC and DC power. The commutator helps in reversing the current direction in the armature windings, maintaining a consistent direction of torque.
- **Series-Wound Design:** The stator's field coils are connected in series with the armature windings. This is similar to the DC series motor. When power is applied, the current flowing through both the field coils and the armature is the same.

### Operation on AC Power:

- **Alternating Magnetic Fields:** When AC power is supplied, the current in both the field coils and armature alternates. This causes the magnetic fields produced by the stator and rotor to reverse direction synchronously with the AC supply.
- **Synchronous Reversal:** The commutator ensures that the armature current direction changes in sync with the AC supply. This synchronization helps to produce a consistent rotational direction, even though the magnetic fields are reversing.

### Advantages:

- **Versatility:** One of the main advantages of universal motors is their ability to run on either AC or DC power. This makes them versatile and useful in applications where the type of available power may vary.
- **High Speed and Power-to-Weight Ratio:** Universal motors can operate at high speeds and are known for their favorable power-to-weight ratio, making them suitable for applications like household appliances (e.g., vacuum cleaners, hair dryers) where high speed and compact size are advantageous.

### Applications:

- **Household Appliances:** Commonly found in devices like vacuum cleaners, power tools, and small appliances due to their high speed and versatility.
- **Portable Tools:** Used in power tools like drills and saws, where high speed and variable power sources are beneficial.

### Limitations:

- **Noise and Wear:** Universal motors can be noisier and wear out more quickly compared to other types of motors due to the mechanical commutation process.
- **Efficiency:** They are generally less efficient than other types of motors like induction motors, especially in AC operation.

In summary, the universal motor is a flexible and robust design that allows for high-speed operation and versatility in power sources, but it comes with trade-offs in terms of noise and efficiency.



# ELECTROMAGNETIC FIELDS

Edited by

**DR.J.SANJEEVIKUMAR**



978-93-6255-069-9

ELECTROMAGNETIC FIELDS

Copyright © 2018 by Dr.J.Sanjeevikumar

All rights reserved. No part of this book may be reproduced or transmitted in any form or by any means without written permission from the author.

ISBN: 978-93-6255-069-9

Publisher: Ponnaiyah Ramajayam Institute of Science and Technology (PRIST)

Date of Publication : 18.8. 2018

## TABLE OF CONTENTS

<b>Introduction</b> .....	<b>07</b>
<b>CHAPTER 1</b> - Electromagnetic Wave Generation and Equations .....	<b>14</b>
Dr.J.Sanjeevikumar	
<b>CHAPTER 2</b> – Electrostatics .....	<b>35</b>
Dr.J.Sanjeevikumar	
<b>CHAPTER 3</b> - Gauss’s Law And Applications .....	<b>73</b>
Dr.J.Sanjeevikumar	
<b>CHAPTER 4</b> - Ohm’s Law And Kirchoff ‘S Laws .....	<b>115</b>
Dr.J.Sanjeevikumar	
<b>CHAPTER 5</b> – Sources And Effects of Electromagnetic Fields .....	<b>158</b>
Dr.J.Sanjeevikumar	
<b>CHAPTER 6</b> – Maxwell’s equations.....	<b>161</b>
Dr.J.Sanjeevikumar	
<b>CHAPTER 7</b> – Boundary conditions.....	<b>172</b>
Dr.J.Sanjeevikumar	
<b>CHAPTER 8</b> – Inductance and magnetic field .....	<b>188</b>
Dr.J.Sanjeevikumar	
<b>CHAPTER 9</b> – Capacitance of Electromagnetic field .....	<b>194</b>
Dr.J.Sanjeevikumar	
<b>CHAPTER 10</b> - Wave propagation .....	<b>205</b>
Dr.J.Sanjeevikumar	
<b>REFERENCES</b> .....	<b>210</b>

# CHAPTER 1

## Electromagnetic Wave Generation and Equations

Dr.J.Sanjeevikumar

*Assistant Professor, Department of Electrical and  
Electronics Engineering Ponnaiyah Ramajayam Institute of  
Science and Technology, Tamil Nadu, India.*

A plane electromagnetic wave traveling in the xxx-direction can be described by sinusoidal functions for the electric and magnetic fields, each oscillating perpendicular to the direction of propagation. The electric field  $\mathbf{E}(x,t)$  and magnetic field  $\mathbf{B}(x,t)$  are related by their amplitudes and phases, and their magnitudes are tied to the speed of light in a vacuum. These waves are solutions to Maxwell's equations and can be expressed as linear superposition's of sinusoidal plane waves.

$$\mathbf{E}(x,t) = \mathbf{E}_{\max} \cos(kx - \omega t + \phi), \quad \mathbf{B}(x,t) = \mathbf{B}_{\max} \cos(kx - \omega t + \phi).$$

$\mathbf{E}$  is the electric field vector, and  $\mathbf{B}$  is the magnetic field vector of the EM wave. For electromagnetic waves  $\mathbf{E}$  and  $\mathbf{B}$  are always perpendicular to each other and perpendicular to the direction of propagation. The direction of propagation is the direction of  $\mathbf{E} \times \mathbf{B}$ .

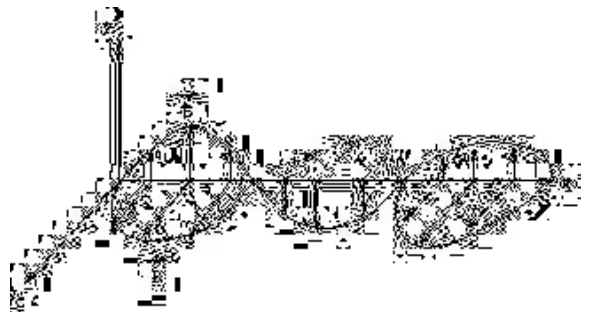

If, for a wave traveling in the x-direction  $\mathbf{E} = E\mathbf{j}$ , then  $\mathbf{B} = B\mathbf{k}$  and  $\mathbf{j} \times \mathbf{k} = \mathbf{i}$ . Electromagnetic waves are transverse waves.

The wave number is  $k = 2\pi/\lambda$ , where  $\lambda$  is the wavelength of the wave. The frequency  $f$  of the wave is  $f = \omega/2\pi$ ,  $\omega$  is the angular frequency. The speed of any periodic wave is the product of its wavelength and frequency.  $v = \lambda f$ .

**The electromagnetic wave equation** is a second-order partial differential equation that describes the propagation of electromagnetic waves through a medium or in a vacuum. It is a three-dimensional form of the wave equation. The homogeneous form of the equation, written in terms of either the electric field  $\mathbf{E}$  or the magnetic field  $\mathbf{B}$ , takes the form:

$$(\nabla^2 - \frac{1}{v_{ph}^2} \frac{\partial^2}{\partial t^2}) \mathbf{E} = 0 \quad (\nabla^2 - \frac{1}{v_{ph}^2} \frac{\partial^2}{\partial t^2}) \mathbf{B} = 0$$

Where  $v_{ph} = 1/\mu\epsilon$

is the speed of light (i.e. phase velocity) in a medium with permeability  $\mu$ , and permittivity  $\epsilon$ , and  $\nabla^2$  is the Laplace operator. In a vacuum,  $v_{ph} = c_0 = 299792458$  m/s, a fundamental physical constant.[1] The electromagnetic wave equation derives from Maxwell's equations. In most older literature,  $\mathbf{B}$  is called the magnetic flux density or magnetic induction. The following

equations  $\nabla \cdot \mathbf{E} = 0$  and  $\nabla \cdot \mathbf{B} = 0$  predicate that any electromagnetic wave must be a transverse wave, where the electric field  $\mathbf{E}$  and the magnetic field  $\mathbf{B}$  are both perpendicular to the direction of wave propagation.

## CHAPTER 2 Electrostatics

Dr.J.Sanjeevikumar

*Assistant Professor, Department of Electrical and  
Electronics Engineering Ponnaiyah Ramajayam Institute of  
Science and Technology, Tamil Nadu, India.*

Electrostatics, the study of electric charges at rest, provides a foundational understanding of how electric forces and fields operate. From ancient observations by Thales to modern applications in technology and materials science, electrostatics underpins much of our understanding of electricity and electromagnetism. Key concepts include Coulomb's Law, electric fields and potentials, and Gauss's Law, all of which are crucial for understanding more complex phenomena in electromagnetism.

Electrostatics is the branch of physics that studies electric charges at rest and the forces and fields associated with them. It deals with the interactions between stationary electric charges and the effects these interactions have on materials and fields. Here's a comprehensive overview of the key concepts and principles in electrostatics.

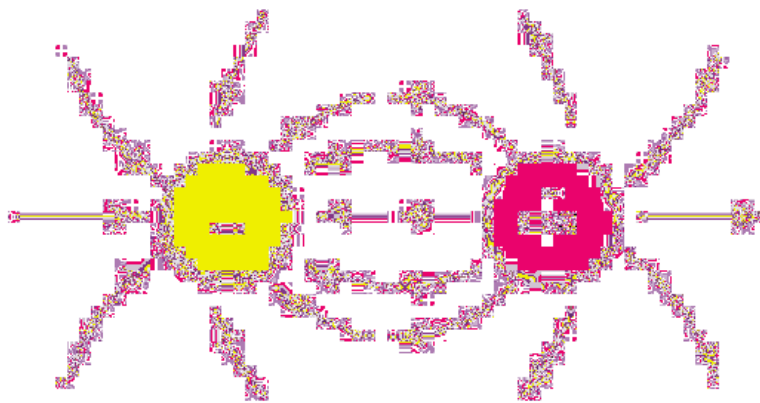

### Coulomb's Law of Electrostatics

Coulomb's Law provides a precise calculation for the electrostatic force between two point charges. By understanding and applying this formula, one can determine both the magnitude and the direction of the force acting between charges in various electrostatic scenarios

$$F = \frac{1}{4\pi\epsilon_0} \frac{qQ}{r^2} = k_e \frac{qQ}{r^2}$$

Or

$$F = k \frac{q_1 q_2}{d^2}$$

## CHAPTER 3

### Gauss's Law And Applications

Dr.J.Sanjeevikumar

*Assistant Professor, Department of Electrical and  
Electronics Engineering Ponnaiyah Ramajayam Institute of  
Science and Technology, Tamil Nadu, India.*

**Gauss law states that the total electric flux in a closed surface would be equivalent to the charge enclosed, separated by the permittivity**

Gauss's Law is a powerful tool for calculating electric fields in cases with high symmetry, such as point charges, infinite planes, and spherical shells. By applying Gauss's Law, you can derive the electric fields around these charge distributions without directly solving Coulomb's Law for each case. This law is fundamental in electromagnetism and is crucial for understanding both electrostatics and the broader principles of electromagnetic theory.

### **Applications of Gauss's Law**

Gauss's Law is essential in electromagnetism for relating electric fields to charge distributions. Developed by Carl Friedrich Gauss, it simplifies the calculation of electric fields in symmetric charge configurations and has broad applications in electrostatics and beyond. Understanding Gauss's Law provides a deep insight into how charges generate electric fields and how these fields interact with materials and other charges.

#### **Electric field due to Uniformly charged Straight wire**

The electric field  $E$  at a distance  $r$  from a long, straight wire with a linear charge density  $\lambda$  is:

This result shows that the electric field around a long, straight wire decreases inversely with the distance from the wire. The cylindrical Gaussian surface simplifies the calculation by utilizing the symmetry of the problem, leading to a straightforward application of Gauss's Law.

If  $2\pi r l$  gives the surface area of the cylindrical surface, then the electric flux through the curve would be  $E \times 2\pi r l$

According to Gauss's Law

$$\Phi = q / \epsilon_0$$

$$E \times 2\pi r l = \lambda l / \epsilon_0$$

$$E = \lambda / 2\pi \epsilon_0 r$$

## CHAPTER 4

### Ohm's Law and Kirchhoff 'S Laws

Dr.J.Sanjeevikumar

*Assistant Professor, Department of Electrical and  
Electronics Engineering Ponnaiyah Ramajayam Institute of  
Science and Technology, Tamil Nadu, India.*

#### Abstract

Ohm's Law and Kirchhoff's Laws are foundational tools for analyzing electrical circuits. By applying these laws, electrical engineers and technicians can solve for unknown currents and voltages in circuits, ensuring accurate and efficient circuit design and troubleshooting. Understanding and applying these principles are crucial skills in electrical engineering and electronics.

After completing this experiment you should:

- (1) Be able to draw the equivalent circuit of simple series and parallel resistor circuits and to calculate the current in such circuits,
- (2) Be able to construct simple series and parallel resistor circuits on your prototype board and to apply power to your circuit using the bench power supply,
- (3) Be able to use the DMM to measure voltage and current at various parts of a given circuit.

#### Ohm's Law

**Ohm's Law** is a fundamental principle in electrical engineering and physics that describes the relationship between voltage, current, and resistance in a circuit. It is named after the German physicist Georg Simon Ohm, who first formulated it.

$$V = I R$$

- **Voltage (V):** The electrical potential difference between two points. It drives the flow of current through a circuit.
- **Current (I):** The flow of electric charge through a conductor. It is driven by the voltage across the conductor.
- **Resistance (R):** The opposition to the flow of current through a conductor. It depends on the material, length, and cross-sectional area of the conductor.

#### Kirchhoff's Laws

**Kirchhoff's Laws** are two fundamental principles used for analyzing electrical circuits. They are named after the German physicist Gustav Kirchhoff, who formulated them.

##### **Kirchhoff's Current Law (KCL)**

**Statement:** The total current entering a junction (or node) in an electrical circuit is equal to the total current leaving the junction.

##### **Kirchhoff's Voltage Law (KVL)**

**Statement:** The sum of all voltages around a closed loop (or mesh) in a circuit is equal to zero.

# CHAPTER 5

## Design of Controllers for Drives

Dr.J.Sanjeevikumar

*Assistant Professor, Department of Electrical and  
Electronics Engineering Ponnaiyah Ramajayam Institute of  
Science and Technology, Tamil Nadu, India.*

### 1. Understanding the Drive System

#### Types of Drives:

- **DC Drives:** Control the speed and direction of DC motors.
- **AC Drives:** Manage AC motors and include variable frequency drives (VFDs) for controlling motor speed by adjusting the frequency and voltage of the power supplied.
- **Stepper Drives:** Used for stepper motors, which move in discrete steps and are commonly used in precise positioning applications.
- **Servo Drives:** Control servo motors, which provide precise control of angular or linear position, velocity, and acceleration.

#### Drive System Components:

- **Motor:** The component that converts electrical energy into mechanical motion.
- **Controller:** The system that adjusts the input to the motor based on feedback and desired performance.
- **Feedback Sensors:** Devices that measure parameters such as speed, position, or current, providing data to the controller.
- **Actuators:** Components that execute commands from the controller.

### 2. Control Objectives

The primary objectives when designing a controller for drives are:

- **Speed Control:** Maintain a desired speed under varying load conditions.
- **Position Control:** Achieve precise positioning of the motor shaft or actuator.
- **Torque Control:** Regulate the torque output of the motor.
- **Efficiency:** Ensure the drive operates efficiently to minimize energy consumption and wear.

#### Introduction

Armature voltage control : retain maximum torque capability

Field flux control (i.e. flux reduced) : reduce maximum torque capability

For wide range of speed control

0 to  $\omega_{base}$  → armature voltage, above  $\omega_{base}$  → field flux reduction

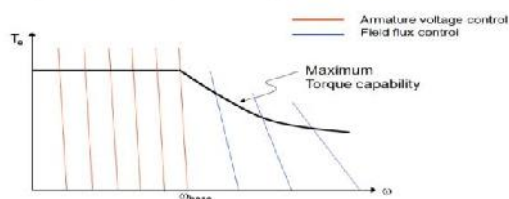



# CHAPTER 6

## Maxwell's equations

Dr.J.Sanjeevikumar

Maxwell's equations are a set of four fundamental equations in electromagnetism that describe how electric and magnetic fields interact and propagate. They form the foundation of classical electrodynamics, optics, and electric circuits. These equations are named after James Clerk Maxwell, who consolidated and formalized them in the 19th century.

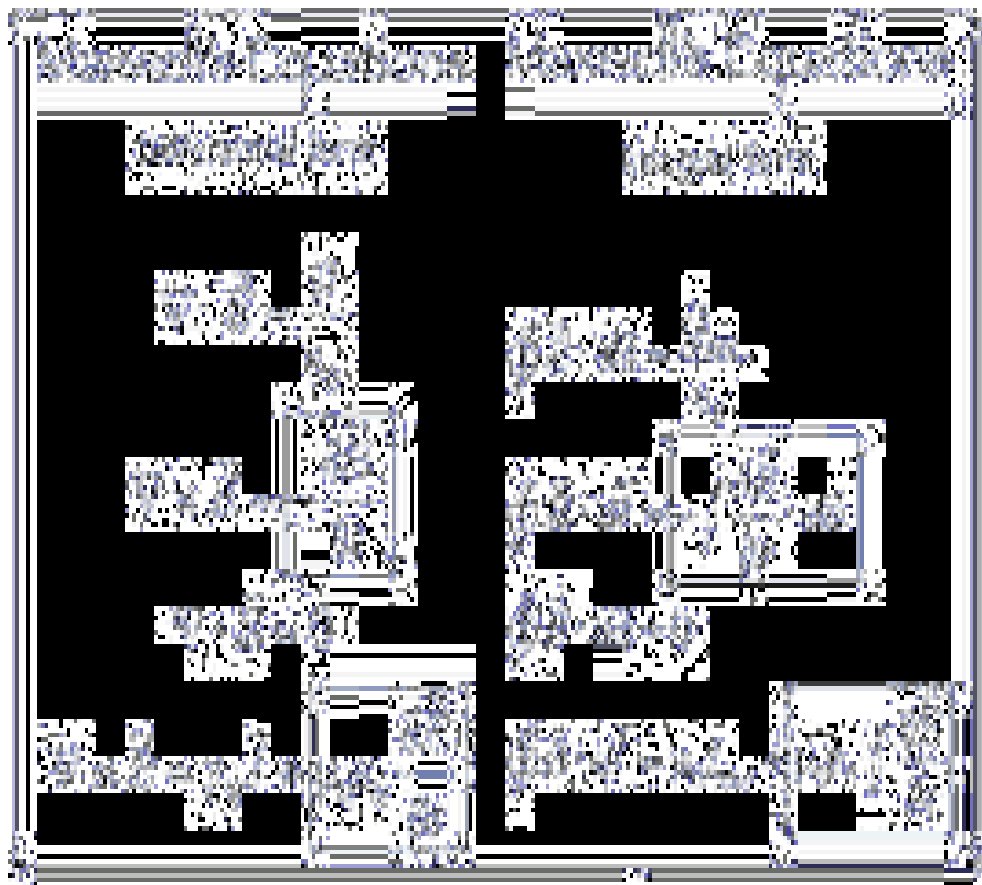
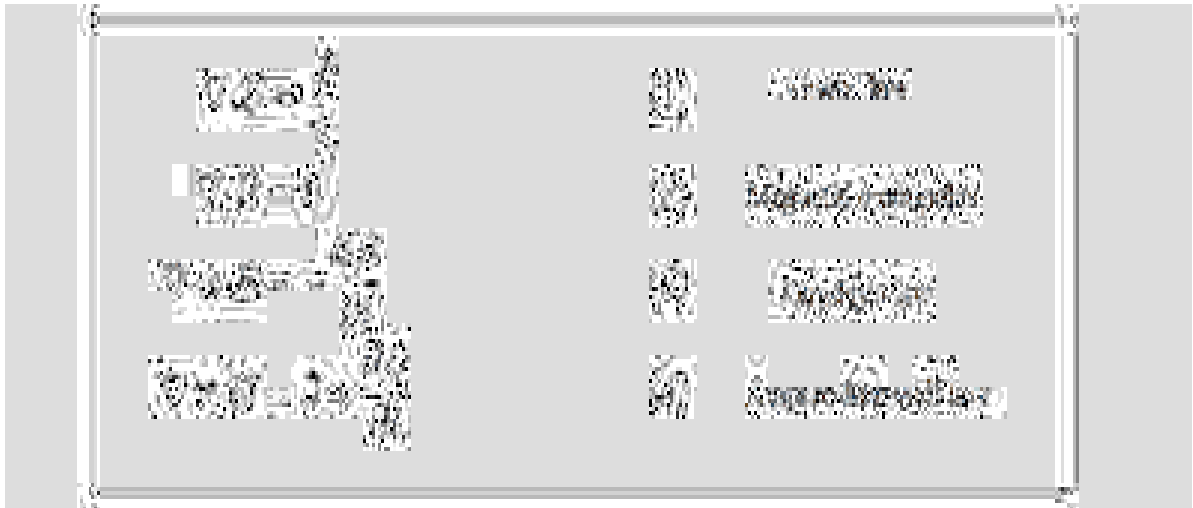

# CHAPTER 7

## Boundary conditions

Dr.J.Sanjeevikumar

Boundary conditions are crucial in solving differential equations that model physical phenomena, especially in fields like electromagnetism, fluid dynamics, and heat transfer. They define the behavior of a system at its boundaries and ensure that solutions to differential equations are physically meaningful and unique.

### Types of Boundary Conditions

#### 1. Dirichlet Boundary Conditions (Fixed Value)

- **Definition:** Specifies the value of the function itself on the boundary of the domain.
- **Example:** In a temperature distribution problem, setting the temperature  $T$  at the boundary of a region to a specific value  $T_0$  is an example of Dirichlet boundary conditions.

#### 2. Neumann Boundary Conditions (Fixed Gradient)

- **Definition:** Specifies the value of the derivative (or gradient) of the function on the boundary of the domain.
- **Example:** In heat transfer problems, specifying the heat flux (rate of heat transfer per unit area) through a boundary can be expressed using Neumann boundary conditions.

#### 3. Robin Boundary Conditions (Convective or Mixed)

- **Definition:** A combination of Dirichlet and Neumann conditions. It specifies a linear combination of the function and its derivative on the boundary.
- **Example:** In heat conduction problems, Robin boundary conditions can model convective heat transfer at the surface of a solid, where  $\alpha$  represents the temperature and  $\beta$  represents the heat transfer coefficient.

#### 4. Periodic Boundary Conditions

- **Definition:** The function and its derivatives are periodic at the boundaries, meaning the function repeats itself after a certain distance.
- **Example:** Periodic boundary conditions are often used in simulations involving materials with repeating structures or in problems with cyclic symmetry.

### Application in Different Fields

#### 1. Electromagnetism

- **Electrostatics:** In electrostatic problems, Dirichlet boundary conditions can specify the electric potential on a boundary, while Neumann conditions can specify the electric field (or charge density).
- **Electromagnetic Waves:** Boundary conditions are used to match the electric and magnetic fields across interfaces between different media.

#### 2. Heat Transfer

- **Heat Conduction:** Dirichlet conditions can set the temperature at the boundary, while Neumann conditions can specify the heat flux. Robin conditions might model convective heat transfer.

#### 3. Fluid Dynamics

- **Navier-Stokes Equations:** Boundary conditions are used to specify velocities (Dirichlet), pressure gradients (Neumann), or combinations of both (Robin) at the boundaries of fluid domains.

#### 4. Structural Mechanics

- **Stress Analysis:** Boundary conditions might involve specifying displacements (Dirichlet) or forces (Neumann) on the boundaries of a structural element.

## CHAPTER 8

### Inductance and magnetic field

Dr.J.Sanjeevikumar

Inductance and magnetic fields are fundamental concepts in electromagnetism and electrical engineering. Understanding their relationship is crucial for designing and analyzing electrical circuits, particularly those involving inductors and transformers. Here's an overview of each concept and their interrelationship:

#### Inductance

**Definition:** Inductance is a property of an electrical component that quantifies its ability to store energy in a magnetic field when current flows through it. It is measured in henrys (H).

#### Properties:

- **Self-Inductance:** The ability of a coil or inductor to induce an electromotive force (EMF) in itself due to a change in current.
- **Mutual Inductance:** The ability of one coil to induce an EMF in a neighboring coil due to a change in current in the neighboring coil.

#### Applications:

- **Inductors:** Components that store energy in a magnetic field and oppose changes in current. Used in filters, transformers, and energy storage systems.
- **Transformers:** Devices that use mutual inductance between coils to transfer electrical energy between circuits.

#### Magnetic Field

**Definition:** A magnetic field is a vector field that describes the magnetic influence of electric currents and magnetic materials. It is generated by moving charges (currents) and can exert forces on other moving charges or magnetic materials.

#### Properties:

- **Direction:** The direction of the magnetic field can be determined using the right-hand rule, where the thumb points in the direction of the current, and the curled fingers point in the direction of the magnetic field lines.
- **Strength:** The strength of the magnetic field is measured in teslas (T) or gauss (G).

#### Applications:

- **Electric Motors and Generators:** Use magnetic fields to convert electrical energy to mechanical energy or vice versa.
- **Magnetic Resonance Imaging (MRI):** Uses strong magnetic fields to create detailed images of the inside of the body.
- **Transformers and Inductors:** Utilize magnetic fields to transfer energy between circuits or store energy.

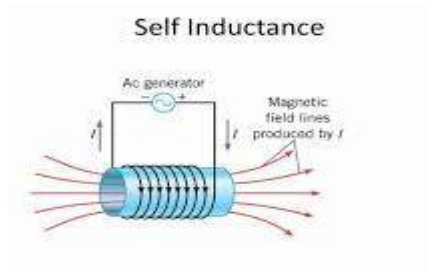

## CHAPTER 9

### Capacitance of Electromagnetic field

Dr.J.Sanjeevikumar

Capacitance in the context of electromagnetic fields is typically associated with how electric fields interact with conductors or dielectric materials to store electrical energy. While capacitance itself is a well-defined concept in circuit theory and electrostatics, its application to electromagnetic fields can be understood through several related concepts:

Capacitance is a fundamental property of systems that store electrical charge and energy, and it is closely related to electric fields in both static and dynamic contexts. In electromagnetic fields, capacitance impacts how electric fields interact with materials and affects system design, especially in high-frequency applications and transmission lines. Understanding capacitance helps in designing efficient circuits and systems, optimizing performance, and managing electromagnetic compatibility.

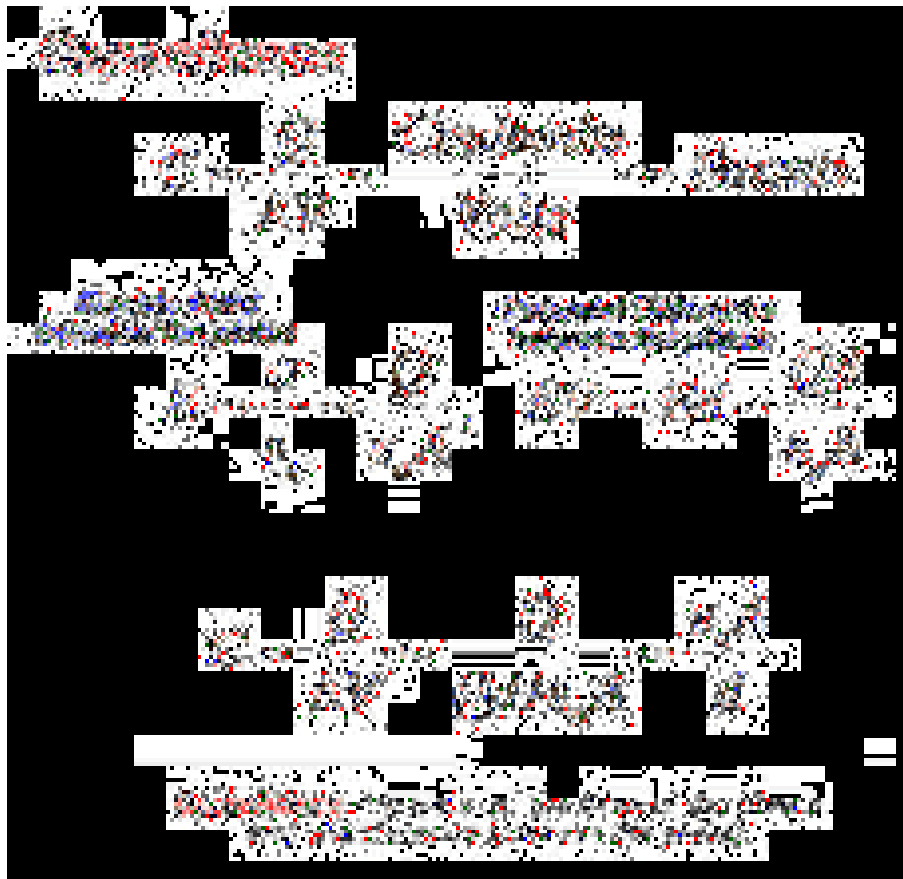

Capacitance is a measure of a structure's ability to store electrical energy in the form of an electric field. It is determined by the geometry of the structure and the permittivity of the medium between the regions of positive and negative charge.

# CHAPTER 10

## Wave propagation

Dr.J.Sanjeevikumar

Wave propagation is the movement of waves through a medium or space. It is a fundamental concept in various fields of physics and engineering, including acoustics, optics, electromagnetism, and seismology. Here's an overview of the key aspects of wave propagation:

### Basic Concepts

#### 1. Wave Definition:

- A wave is a disturbance that travels through a medium (such as water, air, or a solid) or through a vacuum (in the case of electromagnetic waves), transferring energy from one point to another without the permanent displacement of the medium.

#### 2. Types of Waves:

- **Mechanical Waves:** Require a medium to propagate (e.g., sound waves in air, water waves). They can be longitudinal or transverse.
- **Electromagnetic Waves:** Do not require a medium and can propagate through a vacuum (e.g., light, radio waves, X-rays). They are transverse waves.

#### 3. Wave Properties:

- **Wavelength ( $\lambda$ ):** The distance between successive peaks (or troughs) of a wave.
- **Frequency (f):** The number of oscillations or cycles that pass a point per unit time. Measured in hertz (Hz).
- **Amplitude (A):** The maximum displacement from the equilibrium position.
- **Speed (v):** The speed at which the wave propagates through the medium.

### Wave Phenomena

#### 1. Reflection:

- Waves can bounce back when encountering a boundary or obstacle. The angle of incidence equals the angle of reflection (for planar boundaries).

#### 2. Refraction:

- Waves change direction when passing from one medium to another due to a change in speed. Described by Snell's Law:

### Diffraction:

- Waves spread out as they pass through an opening or around an obstacle. The extent of diffraction depends on the wavelength relative to the size of the opening or obstacle.

### Interference:

- When two or more waves overlap, they combine according to the principle of superposition. Constructive interference occurs when waves are in phase, and destructive interference occurs when waves are out of phase.

### Polarization:

- Transverse waves, like light waves, can be polarized, meaning their electric fields oscillate in a particular direction. Polarization filters allow only waves oscillating in certain directions to pass through.

# CONTROL SYSTEMS

EDITED BY

DR.P.AVIRAJAMANJULA



978-93-6255-340-9

CONTROL SYSTEMS

Copyright © 2018 by Dr.P.Avirajamanjula

All rights reserved. No part of this book may be reproduced or transmitted in any form or by any means without written permission from the author.

ISBN: 978-93-6255-340-9

Publisher: Ponnaiyah Ramajayam Institute of Science and Technology (PRIST)

Date of Publication : 15.7.2018

## TABLE OF CONTENTS

<b>Introduction</b>	-	<b>05</b>
<b>CHAPTER 1 - Time Response Analysis</b>	-	<b>12</b>
Mr.R.Elangovan		
<b>CHAPTER 2 - Frequency response analysis</b>	-	<b>38</b>
Mr.R.Elangovan		
<b>CHAPTER 3 - Steady state analysis</b>	-	<b>75</b>
Mrs. M.R. Geetha		
<b>CHAPTER 4 - State variables</b>	-	<b>110</b>
Mr.D.Hariharan		
<b>CHAPTER 5 – Root Locus Technique</b>	-	<b>150</b>
Mr.B.Arunpandiyan		
<b>CHAPTER 6 – Bode plot</b>	-	<b>165</b>
Mr.R.Elangovan		
<b>CHAPTER 7 – Nyquist Plots</b>	-	<b>176</b>
Mr.R.Elangovan		
<b>CHAPTER 8 – Concept of control system</b>	-	<b>182</b>
Mrs. M.R. Geetha		
<b>CHAPTER 9 – PID controllers</b>	-	<b>196</b>
Mr.D.Hariharan		
<b>CHAPTER 10 – Transfer function</b>	-	<b>202</b>
Mr.B.Arunpandiyan		
<b>REFERENCES</b>	-	<b>215</b>



# CHAPTER 1

## Time Response Analysis

*Mr.R.Elangovan*

*Assistant Professor, Department of Electrical and  
Electronics Engineering Ponnaiyah Ramajayam Institute of  
Science and Technology, Tamil Nadu, India.*

### 1. Transient Response:

This is the part of the time response that occurs immediately after a change in input, such as a step input or a disturbance. It represents the system's behavior as it transitions from the initial state to a steady-state condition. The transient response includes characteristics like rise time, settling time, overshoot, and oscillations.

The goal in designing a control system is often to minimize undesirable aspects of the transient response, such as excessive overshoot or long settling times, to ensure the system quickly and smoothly reaches its desired state.

### 2. Steady-State Response:

Once the system has settled from its initial transient behavior, the steady-state response describes how the system behaves under a constant or periodic input. This response shows the long-term behavior of the system and includes characteristics such as the final value or the steady-state error.

The steady-state response is important for ensuring that the system maintains the desired output over time without excessive deviation from the target value.

In summary, the time response of a control system gives a comprehensive view of how the system reacts to inputs over time, with the transient response focusing on the short-term adjustments and the steady-state response focusing on long-term behavior.

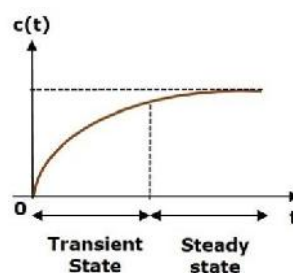

Here, both the transient and the steady states are indicated in the figure. The responses corresponding to these states are known as transient and steady state responses.

- $c(t) = c_{tr}(t) + c_{ss}(t)$

## CHAPTER 2

### Frequency response analysis

Mr.R.Elangovan

*Assistant Professor, Department of Electrical and Electronics Engineering Ponnaiyah Ramajayam Institute of Science and Technology, Tamil Nadu, India.*

The response of a system can be partitioned into both the transient response and the steady state response. We can find the transient response by using Fourier integrals. The steady state response of a system for an input sinusoidal signal is known as the frequency response. In this chapter, we will focus only on the steady state response.

If a sinusoidal signal is applied as an input to a Linear Time-Invariant (LTI) system, then it produces the steady state output, which is also a sinusoidal signal. The input and output sinusoidal signals have the same frequency, but different amplitudes and phase angles.

Let the input signal be –

$$r(t) = A \sin(\omega_0 t) \quad r(t) = A \sin^{[\dots]}(\omega_0 t)$$

The open loop transfer function will be –

$$G(s) = G(j\omega) \quad G(s) = G(j\omega)$$

We can represent  $G(j\omega)$  in terms of magnitude and phase as shown below.

$$G(j\omega) = |G(j\omega)| \angle G(j\omega) \quad G(j\omega) = |G(j\omega)| \angle G(j\omega)$$

Substitute,  $\omega = \omega_0$  in the above equation.

$$G(j\omega_0) = |G(j\omega_0)| \angle G(j\omega_0) \quad G(j\omega_0) = |G(j\omega_0)| \angle G(j\omega_0)$$

The output signal is

$$c(t) = A |G(j\omega_0)| \sin(\omega_0 t + \angle G(j\omega_0)) \quad c(t) = A |G(j\omega_0)| \sin^{[\dots]}(\omega_0 t + \angle G(j\omega_0))$$

The amplitude of the output sinusoidal signal is obtained by multiplying the amplitude of the input sinusoidal signal and the magnitude of  $G(j\omega)$  at  $\omega = \omega_0$ .

The phase of the output sinusoidal signal is obtained by adding the phase of the input sinusoidal signal and the phase of  $G(j\omega)$  at  $\omega = \omega_0$ .

## CHAPTER 3

### Steady state analysis

Mrs. M.R. Geetha

*Assistant Professor, Department of Electrical and  
Electronics Engineering Ponnaiyah Ramajayam Institute of  
Science and Technology, Tamil Nadu, India.*

The steady-state error  $e_{ss}$  is a crucial metric for evaluating the accuracy and performance of a control system in reaching and maintaining its desired output. The Final Value Theorem provides a straightforward method to calculate  $e_{ss}$  using the Laplace transforms of the system's transfer function and input.

$$e_{ss} = \lim_{t \rightarrow \infty} e(t) = \lim_{s \rightarrow 0} sE(s)$$

Where,  $E(s)$  is the Laplace transform of the error signal,  $e(t)$

Let us discuss how to find steady state errors for unity feedback and non-unity feedback control systems one by one.

Steady State Errors for Unity Feedback Systems

Consider the following block diagram of closed loop control system, which is having unity negative feedback.

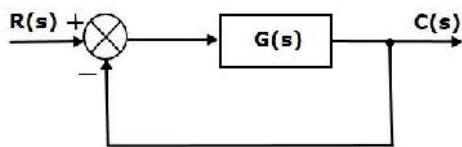

Where,  $R(s)$  is the Laplace transform of the reference Input signal  $r(t)$

$C(s)$  is the Laplace transform of the output signal  $c(t)$

We know the transfer function of the unity negative feedback closed loop control system as

$$C(s)R(s) = G(s)1 + G(s)C(s)R(s) = G(s)1 + G(s)$$

$$\Rightarrow C(s) = R(s)G(s)1 + G(s) \Rightarrow C(s) = R(s)G(s)1 + G(s)$$

The output of the summing point is -  $E(s) = R(s) - C(s)$

Substitute  $C(s)$  value in the above equation.

$$E(s) = R(s) - R(s)G(s)1 + G(s) \Rightarrow E(s) = R(s) - R(s)G(s)1 + G(s)$$

$$\Rightarrow E(s) = R(s) + R(s)G(s) - R(s)G(s)1 + G(s) \Rightarrow E(s) = R(s) + R(s)G(s) - R(s)G(s)1 + G(s)$$

$$\Rightarrow E(s) = R(s)1 + G(s) \Rightarrow E(s) = R(s)1 + G(s)$$

Substitute  $E(s)$  value in the steady state error formula

$$e_{ss} = \lim_{s \rightarrow 0} sR(s)1 + G(s)$$

## CHAPTER 4 State variables

Mr.D.Hariharan

*Assistant Professor, Department of Electrical and  
Electronics Engineering Ponnaiyah Ramajayam Institute of  
Science and Technology, Tamil Nadu, India.*

### State-Variable Form

A **state-variable model** is a mathematical representation of a system using a set of first-order differential equations. These models are particularly useful in control theory and systems engineering because they provide a comprehensive framework for analyzing and designing systems.

### Key Characteristics:

### State-Space Representation:

- **State Equations:** The state variables are used in a set of coupled first-order differential equations, which describe how the state of the system evolves over time.
- **Output Equations:** These equations relate the state variables to the system's output.

The general form of the state-space representation is:

$$\dot{x}(t) = Ax(t) + Bu(t)$$

**Example 1:** A system is described by the state equation  $X' = AX + BU$ . The output is given by  $Y = CX$ , where

$$A = \begin{bmatrix} -4 & -1 \\ 3 & -1 \end{bmatrix} \text{ and } B = \begin{bmatrix} 1 \\ 1 \end{bmatrix} \quad \text{And } C = [1 \ 0]$$

The transfer function of the system is:

1.  $s/s^2 + 5s + 7$
2.  $2s/s^2 + 5s + 7$
3.  $1/s^2 + 5s + 7$
4.  $s/s^2 + 3s + 5$

**Answer:** (a)  $s/s^2 + 5s + 7$

### Advantages of state variable analysis

This can be applicable to

- Linear systems
- Non-linear system

# CHAPTER 5

## Design of Controllers for Drives

Mr.B.Arunpandiyan

*Assistant Professor, Department of Electrical and  
Electronics Engineering Ponnaiyah Ramajayam Institute of  
Science and Technology, Tamil Nadu, India.*

Control design is a fundamental discipline in systems engineering, aimed at ensuring that systems operate according to desired specifications. By implementing various types of controllers and utilizing different design techniques, engineers can manage and influence the behavior of complex systems, such as power generation units and FACTS devices, to achieve stability, performance, and robustness

### Introduction

Control system design is a complex process involving careful consideration of performance goals and physical constraints. The need to balance high performance with practical limitations often requires making trade-offs and adjustments to design specifications. A critical phase in this process is assessing the feasibility of design goals and making informed decisions to relax or adjust goals as needed. By understanding and managing these trade-offs, engineers can develop effective control systems that meet practical requirements while striving to achieve optimal performance.

### Control Systems Design Process

Effective control system design requires not only a clear expression of how the system is intended to operate but also a well-defined framework of responsibilities. By providing detailed documentation, clear design intent, and specifying roles and responsibilities, the designer ensures that the control system is built and implemented according to the desired specifications. This approach facilitates successful collaboration among team members, minimizes misunderstandings, and enhances the overall effectiveness of the project.

In the context of modern, complex control systems, performance-based design offers flexibility and encourages innovation by focusing on desired outcomes rather than prescriptive solutions. The contractor plays a crucial role in interpreting the intent of the contract documents, directing their team, and ensuring that the control system is implemented to meet the specified performance criteria. Effective communication, coordination, and adherence to performance goals are essential for the successful execution of performance-based control system projects.

**Understanding Intent:** The contractor is responsible for thoroughly understanding the performance requirements specified in the contract documents. This involves interpreting how the desired outcomes should be achieved and ensuring that the proposed solutions align with the project goals.

## CHAPTER 6

### Bode plot

Mr.R.Elangovan

Bode plot is a graphical method used in engineering and control theory to analyze the frequency response of a system. It consists of two plots:

#### Bode Plot Details:

##### 1. Magnitude Plot:

- **Purpose:** Shows how the amplitude of the output varies with frequency.
- **Scaling:** Typically plotted on a logarithmic scale for frequency and decibels (dB) for magnitude. This logarithmic scaling makes it easier to visualize changes over a wide range of frequencies.

##### 2. Phase Plot:

- **Purpose:** Illustrates how the phase of the system's output signal shifts relative to the input signal across different frequencies.
- **Scaling:** Plotted in degrees versus frequency on a logarithmic scale. The phase shift helps in understanding how different frequency components are altered by the system.

#### Applications and Comparisons:

- **Stability Analysis:** Bode plots are crucial for assessing stability, particularly through gain and phase margins. The gain margin is the amount by which the gain can be increased before the system becomes unstable, while the phase margin is the additional phase lag required to bring the system to the verge of instability.
- **Right Half-Plane Poles/Zeros:** One of the strengths of Bode plots is their ability to handle transfer functions with right half-plane (RHP) poles, which represent unstable behavior in the Laplace domain. This is in contrast to the Nyquist criterion, which can be more complex to apply in such cases.
- **Control Design:** Engineers use Bode plots to design and tune controllers. By adjusting the system's parameters, the Bode plot helps ensure that the system meets performance requirements such as bandwidth, stability, and robustness.

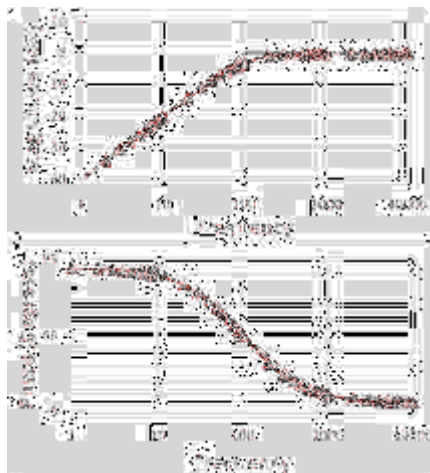

# CHAPTER 7

## Nyquist Plots

Mr.R.Elangovan

Nyquist plots are a powerful tool in control system engineering for analyzing the stability and performance of a system. They are used to visualize the frequency response of a system's transfer function and assess stability, particularly with respect to the Nyquist stability criterion.

### What is a Nyquist Plot?

A Nyquist plot is a graphical representation of the frequency response of a system's transfer function  $H(j\omega)$  in the complex plane. It maps the complex values of  $H(j\omega)$  as the frequency  $\omega$  varies from 0 to  $\infty$ . Essentially, it traces out the locus of the transfer function's values over a range of frequencies.

Electrochemical Impedance Spectroscopy (EIS) is a technique used to characterize the electrical properties of electrochemical systems by applying a small alternating current (AC) signal and measuring the resulting voltage response. This method provides valuable insights into the resistance, capacitance, and inductance of the system under study.

### Impedance Measurement:

- **Impedance** ( $Z$ ) is a complex quantity representing the opposition that a circuit presents to an AC signal. It combines resistance ( $R$ ) and reactance ( $X$ ), and can be expressed as  $Z=R+jX$ , where  $j$  is the imaginary unit.
- In EIS, the impedance is measured over a range of frequencies, typically from very low (mHz) to high (kHz or MHz) frequencies.

### Plot Interpretation:

- **Semicircle:** A common feature in Nyquist plots is a semicircular arc, which often represents the charge transfer resistance and double-layer capacitance of an electrochemical cell.
- **High-Frequency Region:** At high frequencies, the plot tends to approach the real axis, indicating the resistance of the system.
- **Low-Frequency Region:** At low frequencies, the plot can show a depressed semicircle or a straight line, representing diffusion or other complex impedance elements.

### Equivalent Circuit Models:

- The Nyquist plot is often used to fit equivalent circuit models to the impedance data. These models can include resistors, capacitors, inductors, and elements that account for constant phase elements (CPE) or Warburg impedance.
- By fitting these models, you can extract parameters such as resistance, capacitance, and diffusion coefficients.

### Applications:

- **Corrosion Studies:** EIS can be used to evaluate the corrosion resistance of materials by analyzing the impedance response.
- **Battery Testing:** It helps in assessing the state of health and performance of batteries by examining their impedance characteristics.
- **Fuel Cells:** EIS is used to study the behavior of fuel cells, including the effects of different operating conditions and degradation mechanisms.
- **Sensors:** Impedance spectroscopy is employed in sensor development to improve sensitivity and selectivity.

# CHAPTER 8

## Concept of control system

Mrs. M.R. Geetha

The concept of a control system is central to engineering and automation, as it involves the management of dynamic systems to achieve desired performance. Here's a detailed overview of what a control system is, how it works, and its various types and applications:

### Definition

A control system is a set of devices or algorithms that manage the behavior of a dynamic system to achieve specific objectives. It typically involves regulating, commanding, or managing the behavior of systems by adjusting inputs to produce desired outputs.

### Basic Components

1. **Plant:** The system or process being controlled. For instance, in a temperature control system, the plant might be a furnace.
2. **Controller:** The component that determines the appropriate action based on the difference between the desired setpoint and the actual output. It generates the control signal to adjust the plant.
3. **Sensor:** Measures the output of the plant and provides feedback to the controller. For example, a thermometer in a temperature control system.
4. **Actuator:** Implements the control signal from the controller by influencing the plant. In the furnace example, this might be a heating element or a valve.
5. **Feedback:** The process of using the sensor's measurements to adjust the controller's actions. Feedback helps correct errors and stabilize the system.
6. **Reference Input (Setpoint):** The desired value or trajectory that the system aims to achieve. For example, the target temperature for the furnace.

### Types of Control Systems

1. **Open-Loop Control System:**
  - **Definition:** A system where the output is not fed back to the controller. The control action is independent of the output.
  - **Example:** A basic washing machine that operates based on a preset cycle time without measuring the actual cleanliness of the clothes.
2. **Closed-Loop Control System:**
  - **Definition:** A system where the output is fed back to the controller to make adjustments and correct any deviation from the setpoint.
  - **Example:** A thermostat-controlled heating system that adjusts the temperature by continually measuring and responding to the actual room temperature.

### Control Strategies

1. **Proportional Control (P):**
  - Adjusts the control input proportional to the error (the difference between the setpoint and the measured output).
  - **Pros:** Simple and effective for many systems.
  - **Cons:** Can lead to steady-state error and may not eliminate it completely.
2. **Integral Control (I):**
  - Adjusts the control input based on the accumulation of past errors.
  - **Pros:** Eliminates steady-state error.
  - **Cons:** Can lead to increased oscillations and slower response.



# CHAPTER 9

## PID controllers

*Mr.R.Elangovan*

PID controllers are one of the most commonly used control strategies in industrial control systems. The acronym PID stands for Proportional, Integral, and Derivative, which are the three key components that make up this control strategy. Here's a detailed look at PID controllers:

### Components of PID Controllers

#### 1. Proportional Control (P):

- **Function:** Adjusts the control output proportional to the current error. The error is the difference between the setpoint (desired value) and the measured process variable (actual value).
- **Effect:** Provides immediate response to changes in error. A higher  $K_p$  increases the response speed but can also lead to overshoot and instability.

#### 2. Integral Control (I):

- **Function:** Adjusts the control output based on the accumulation of past errors. It integrates the error over time to eliminate steady-state errors.
- **Effect:** Eliminates steady-state error but can cause the system to become sluggish and oscillatory if over-tuned.

#### 3. Derivative Control (D):

- **Function:** Adjusts the control output based on the rate of change of the error. It anticipates future errors by considering the rate at which the error is changing.
- **Effect:** Improves system stability and reduces overshoot by responding to the rate of change of the error. However, it can amplify noise if not properly tuned.

### Tuning PID Controllers

Tuning involves setting the values of  $K_p$ ,  $K_i$ , and  $K_d$  to achieve desired performance characteristics such as stability, speed of response, and minimal overshoot. There are several methods for tuning PID controllers:

1. **Manual Tuning:** Adjusting the parameters based on experience and trial-and-error.
2. **Ziegler-Nichols Method:** A popular empirical method involving increasing the proportional gain until the system starts to oscillate and then using this information to set the integral and derivative gains.
3. **Cohen-Coon Method:** Another empirical approach based on process dynamics and open-loop step responses.
4. **Software-Based Tuning:** Modern control systems often use optimization algorithms and software tools to automatically tune PID parameters.

### Applications

PID controllers are widely used in various applications, including:

- **Industrial Process Control:** Regulating temperature, pressure, flow, and other process variables.
- **Manufacturing:** Controlling robotic arms, conveyor belts, and other machinery.
- **Automotive Systems:** Managing cruise control, engine performance, and braking systems.
- **Aerospace:** Stabilizing flight controls and navigation systems.
- **HVAC Systems:** Regulating heating, ventilation, and air conditioning systems.

# CHAPTER 10

## Transfer function

Mr.B.Arunpandiyan

A transfer function is a mathematical representation of the relationship between the input and output of a linear time-invariant (LTI) system in the Laplace transform domain. It is a fundamental concept in control systems and signal processing, providing a concise way to analyze and design systems.

### Definition

For a linear time-invariant (LTI) system, the transfer function  $H(s)$  is defined as the ratio of the Laplace transform of the output  $Y(s)$  to the Laplace transform of the input  $X(s)$  assuming all initial conditions are zero:

$$H(s) = Y(s) / X(s)$$

### Applications

#### 1. System Analysis:

- Transfer functions are used to analyze the stability, frequency response, and transient response of a system.

#### 2. Control System Design:

- Engineers use transfer functions to design controllers and compensators, such as PID controllers, by modifying the open-loop transfer function to achieve desired closed-loop performance.

#### 3. Signal Processing:

- Transfer functions help in designing filters and understanding how signals are modified by different systems.

The transfer function is a fundamental tool in control systems and signal processing, providing a convenient way to analyze and design systems by representing their behavior in the Laplace domain. It encapsulates the dynamic relationship between the input and output, helping engineers understand system characteristics and design appropriate control strategies.

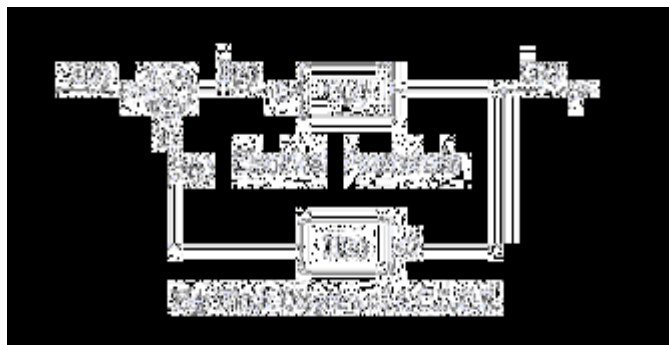

### Convenience and Representation

- **Convenience:** The transfer function is a powerful tool for analyzing and designing linear time-invariant (LTI) systems because it simplifies the analysis of complex systems by transforming differential equations into algebraic equations using the Laplace transform.
- **Linear Time-Invariant (LTI) Systems:** These systems are characterized by their linearity (superposition principle) and time invariance (system properties do not change over time). For such systems, the transfer function provides a direct relationship between input and output in the frequency domain.



# FLUID MECHANICS

Edited by

**DR. IRAIKARKUZHALI**

---



978-93-6255-349-2

**FLUID MECHANICS**

Copyright © 2018 by Dr.Iraikarkuzhali

All rights reserved. No part of this book may be reproduced or transmitted in any form or by any means without written permission from the author.

ISBN: 978-93-6255-349-2

Publisher: Ponnaiyah Ramajayam Institute of Science and Technology (PRIST)

## TABLE OF CONTENTS

<b>Introduction</b>	-	05
<b>CHAPTER 1 - Fluid Properties And Fluid Statics</b> Mr. D.Jeya Kumar	-	10
<b>CHAPTER 2 - Fluid Kinematics And Dynamics</b> Ms. A.Belciya Mary	-	25
<b>CHAPTER 3 - Dimensional Analysis And Model Studies</b> Mrs.Devi	-	60
<b>CHAPTER 4 - Flow Through Pipes</b> Mr.S.Ravishankar	-	100
<b>CHAPTER 5 – Boundary Layer</b> Mr. S.Ramakrishnan	-	120
<b>CHAPTER 6- Properties Of Fluids</b> D.Jeyakumar	-	130
<b>CHAPTER 7- Pressure Measurementsb.</b> Mr.Jose Ravindra Raj	-	138
<b>CHAPTER 8- Hydrostatic Forces on the surface</b> Mrs.Santhiyaa Jenifer	-	145
<b>CHAPTER 9 Types Of Fluid Flow</b> Mrs.K.Shanthi	-	156
<b>CHAPTER 10 Bernoullis Theoram</b> Mrs.R.Devi	-	165
<b>REFERENCES</b>	-	<b>180</b>

**CHAPTER 1**  
**Fluid Properties and Fluid Statics**  
Mr. D.Jeya Kumar

Fluid properties and fluid statics are fundamental concepts in fluid mechanics. Here's a brief overview of each:

### Fluid Properties

1. **Density ( $\rho$ ):**

- Density is the mass per unit volume of a fluid. It's a measure of how compact the fluid is.
- For liquids, density is relatively constant, but for gases, it can vary with pressure and temperature.
- Mathematically,  $\rho = \frac{m}{V}$ , where m is mass and V is volume.

2. **Pressure (P):**

- Pressure is the force exerted per unit area. In fluids, pressure acts in all directions and is due to the weight of the fluid above.
- It is measured in units like Pascals (Pa), atmospheres (atm), or bar.

3. **Viscosity ( $\mu$ ):**

- Viscosity is a measure of a fluid's resistance to deformation or flow. It can be thought of as the "thickness" of the fluid.
- Dynamic viscosity ( $\mu$ ) quantifies the internal friction of a moving fluid, while kinematic viscosity ( $\nu$ ) is the ratio of dynamic viscosity to density ( $\nu = \frac{\mu}{\rho}$ ).

4. **Surface Tension ( $\sigma$ ):**

- Surface tension is the force per unit length acting at the surface of a liquid, causing it to behave like a stretched elastic membrane.
- It is responsible for phenomena like the formation of droplets and the ability of some insects to walk on water.

5. **Specific Gravity (SG):**

- Specific gravity is the ratio of the density of a fluid to the density of a reference fluid, typically water.
- It is a dimensionless quantity and provides a quick way to compare densities.

### Fluid Statics

Fluid statics (or hydrostatics) is the study of fluids at rest and the forces and conditions associated with them.

1. **Hydrostatic Pressure:**

- In a fluid at rest, pressure increases with depth due to the weight of the fluid above. This can be described by the hydrostatic pressure equation:

$$P = P_0 + \rho gh$$

where P is the pressure at depth h,  $P_0$  is the pressure at the surface,  $\rho$  is the fluid density, and g is the acceleration due to gravity.

2. **Pascal's Principle:**

- Pascal's Principle states that a change in pressure applied to an enclosed fluid is transmitted undiminished to every point of the fluid and to the walls of its container.
- This principle is used in hydraulic systems like car brakes and lifts.

**CHAPTER 2**  
**Fluid Kinematics and Dynamics**  
Ms. A.Belciya Mary

Fluid kinematics and dynamics are crucial aspects of fluid mechanics, each focusing on different characteristics and behaviors of fluids.

### **Fluid Kinematics**

Fluid kinematics is the study of fluid motion without considering the forces that cause this motion. It deals with the description of flow patterns and the movement of fluid particles.

1. **Flow Types:**

- **Laminar Flow:** Smooth and orderly flow where fluid particles move in parallel layers. It occurs at low velocities and is characterized by a Reynolds number less than 2000.
- **Turbulent Flow:** Chaotic and irregular flow with mixing and eddies. It occurs at higher velocities and is characterized by a Reynolds number greater than 4000.
- **Transitional Flow:** A mix of laminar and turbulent flow, occurring between the two extremes.

2. **Flow Lines:**

- **Streamlines:** Lines that represent the direction of fluid flow at any point. The tangent to a streamline at any point gives the direction of the flow at that point.
- **Pathlines:** The actual path traced by a fluid particle over time.
- **Streaklines:** The line formed by all particles that have passed through a particular point in the past.

3. **Continuity Equation:**

- The continuity equation expresses the conservation of mass in a flowing fluid. For incompressible fluids, it is given by:

$$A_1 v_1 = A_2 v_2$$

where A is the cross-sectional area and v is the flow velocity at different points in the fluid.

4. **Velocity Field:**

- Describes the velocity of fluid particles at every point in the fluid. For steady flows, the velocity field does not change with time.

5. **Acceleration Field:**

- **Local Acceleration:** The change in velocity with time at a fixed point.
- **Convective Acceleration:** The change in velocity due to the movement of fluid particles through a velocity field.

### **Fluid Dynamics**

Fluid dynamics focuses on the forces and energy involved in fluid motion. It involves analyzing the causes of flow and the resulting effects.

1. **Navier-Stokes Equations:**

- These fundamental equations describe the motion of fluid substances. They account for the velocity field, pressure, viscosity, and external forces.

**CHAPTER 3**  
**Dimensional Analysis and Model Studies**  
Mrs.Devi

Dimensional analysis and model studies are powerful tools in fluid mechanics and engineering that help simplify complex problems and make predictions about real-world systems.

### Dimensional Analysis

**Dimensional analysis** is a method used to analyze the relationships between physical quantities by examining their dimensions (e.g., length, time, mass). It simplifies complex physical problems and scales them to practical scenarios.

#### Key Concepts

1. **Dimensional Homogeneity:**

- Equations must be dimensionally consistent. Each term in an equation must have the same dimensional units. For example, in the equation  $F=ma$  force  $F$ , mass  $m$ , and acceleration  $a$  must all be dimensionally consistent.

2. **Dimensional Form of Quantities:**

- Each physical quantity can be expressed in terms of fundamental dimensions. For instance:
  - Length [L]
  - Mass [M]
  - Time [T]
  - Force [MLT<sup>-2</sup>]
  - Velocity [LT<sup>-1</sup>]

3. **Buckingham Pi Theorem:**

- This theorem provides a systematic way to reduce the number of variables in a problem by forming dimensionless parameters ( $\pi$ -groups). It states that if there are  $n$  variables and  $k$  fundamental dimensions, then the problem can be reduced to  $n-k$  dimensionless parameters.

**Example:** For fluid flow over a plate, parameters like velocity, viscosity, and plate length can be combined to form dimensionless groups such as the Reynolds number  $R_e = \frac{\rho v L}{\mu}$

#### Similarity Criteria:

- Dimensional analysis helps establish similarity criteria for model testing, ensuring that the model and the prototype exhibit similar behavior.

#### Applications

- **Scaling Laws:** To predict the behavior of large systems based on small-scale models.
- **Design and Testing:** To simplify complex design processes and validate through model testing.

#### Model Studies

**Model studies** involve creating scaled-down or scaled-up versions of physical systems to study their behavior. These studies are essential in many engineering fields, such as aerodynamics, hydrodynamics, and civil engineering.



## CHAPTER 4 Flow Through Pipes

Mr.S.Ravishankar

Flow through pipes is a fundamental topic in fluid mechanics, involving the study of how fluids move through cylindrical conduits. The behavior of this flow is crucial in various applications, from water supply systems to industrial processes. Here's an overview of the key concepts and equations related to pipe flow:

### Key Concepts

#### 1. Types of Flow:

- **Laminar Flow:** Occurs at lower velocities and is characterized by smooth, orderly motion. It follows a parabolic velocity profile, with the maximum velocity at the center of the pipe. It is described by the Hagen-Poiseuille equation.
- **Turbulent Flow:** Occurs at higher velocities and is characterized by chaotic, irregular motion with eddies and mixing. The velocity profile is flatter in the center and has higher frictional losses. It is described using empirical correlations like the Darcy-Weisbach equation and Reynolds number.
- **Transition Flow:** Occurs between laminar and turbulent flow regimes, where the flow can exhibit characteristics of both types.

#### 2. Reynolds Number (Re):

- A dimensionless number used to predict flow regimes. It is defined as:

$$Re = \frac{\rho v D}{\mu}$$

where  $\rho$  is the fluid density,  $v$  is the flow velocity,  $D$  is the pipe diameter, and  $\mu$  is the dynamic viscosity. For flow in pipes:

- Laminar flow:  $Re < 2000$
- Turbulent flow:  $Re > 4000$
- Transitional flow:  $2000 < Re < 4000$

#### 3. Pipe Roughness:

- Surface roughness of the pipe affects flow resistance, especially in turbulent flow. It is characterized by the roughness height ( $e$ ), which influences the friction factor.

### Key Equations

#### 1. Continuity Equation:

- Ensures the conservation of mass in a pipe flow

$$A_1 v_1 = A_2 v_2$$

where  $A$  is the cross-sectional area of the pipe and  $v$  is the velocity.

#### 2. Darcy-Weisbach Equation:

- Used to calculate the pressure loss due to friction in a pipe:

$$\Delta P = f \frac{L}{D} \frac{1}{2} \rho v^2$$

**CHAPTER 5**  
**Boundary Layer**  
Mr. S.Ramakrishnan

The boundary layer is a fundamental concept in fluid mechanics that describes the layer of fluid close to a solid boundary where the effects of viscosity are significant. Understanding the boundary layer is crucial for analyzing and predicting fluid behavior in various engineering applications, such as aerodynamics, hydrodynamics, and heat transfer.

### Key Concepts of Boundary Layer

1. **Definition:**

- The boundary layer is the thin region of fluid near a solid surface where the velocity of the fluid transitions from zero (at the surface due to the no-slip condition) to the free-stream velocity (the velocity far from the surface).

2. **No-Slip Condition:**

- At the solid boundary, the fluid's velocity is zero relative to the surface due to viscous forces. This is known as the no-slip condition.

3. **Boundary Layer Growth:**

- As fluid flows along a surface, the boundary layer grows in thickness. The thickness increases with distance from the leading edge of the surface due to the effects of viscous shear.

4. **Velocity Profile:**

- Within the boundary layer, the velocity profile typically starts from zero at the surface and asymptotically approaches the free-stream velocity. The exact shape of the velocity profile depends on the flow regime (laminar or turbulent).

### Types of Boundary Layers

1. **Laminar Boundary Layer:**

- Characterized by smooth, orderly flow with a well-defined velocity gradient. It usually occurs at lower Reynolds numbers and is governed by the Blasius solution for a flat plate.
- The velocity profile in a laminar boundary layer is parabolic.

2. **Turbulent Boundary Layer:**

- Characterized by chaotic, irregular flow with significant mixing and fluctuating velocity. It occurs at higher Reynolds numbers and is influenced by turbulence.
- The velocity profile in a turbulent boundary layer is flatter near the wall compared to the laminar case and includes a region with a log-law velocity profile.

3. **Transitional Boundary Layer:**

- The region where the boundary layer transitions from laminar to turbulent flow. This transition depends on factors like surface roughness, pressure gradients, and flow disturbances.

### Boundary Layer Equations

1. **Blasius Solution** (for Laminar Flow over a Flat Plate):

- The Blasius solution provides an exact solution to the boundary layer equations for steady, incompressible, laminar flow over a flat plate. It describes the velocity profile and boundary layer thickness.
- The boundary layer thickness  $\delta$  can be approximated as

**CHAPTER 6**  
**Properties Of Fluids**  
D.Jeyakumar

Fluids, which include liquids and gases, have several important properties that define their behavior. Here are some key properties:

**1. Density**

- The mass per unit volume of a fluid, usually expressed in  $\text{kg/m}^3$ . Density varies with temperature and pressure, especially in gases.

**2. Viscosity**

- A measure of a fluid's resistance to flow. High viscosity fluids (like honey) flow slowly, while low viscosity fluids (like water) flow easily. Viscosity can change with temperature.

**3. Pressure**

- The force exerted by a fluid per unit area, typically measured in pascals (Pa). Pressure in a fluid increases with depth due to the weight of the fluid above.

**4. Buoyancy**

- The upward force exerted by a fluid on an object submerged in it. This force is equal to the weight of the fluid displaced by the object, as described by Archimedes' principle.

**5. Surface Tension**

- The property that allows a fluid's surface to behave like a stretched elastic membrane. It results from cohesive forces between liquid molecules, affecting phenomena like droplet formation.

**6. Compressibility**

- The ability of a fluid to change its volume under pressure. Gases are more compressible than liquids, which are generally considered incompressible.

**7. Flow Behavior**

- Fluids can be classified as:
  - **Laminar Flow:** Smooth and orderly flow, where fluid moves in parallel layers.
  - **Turbulent Flow:** Chaotic and irregular flow, characterized by eddies and vortices.

**8. Thermal Conductivity**

- The ability of a fluid to conduct heat. This property affects how fluids transfer heat energy, impacting processes like convection.

**9. Specific Heat Capacity**

# CHAPTER 7

## Pressure Measurementsb.

Jose Ravindra Raj

Sure! Pressure measurements are crucial in various fields, including meteorology, engineering, and medicine. Here are some key concepts:

### Types of Pressure

1. **Absolute Pressure:** Measurement relative to a perfect vacuum.
2. **Gauge Pressure:** Measurement relative to atmospheric pressure (often what pressure gauges display).
3. **Differential Pressure:** Difference between two pressure points, useful in flow measurements.

### Units of Measurement

- **Pascal (Pa):** SI unit of pressure.
- **Bar:** 1 bar = 100,000 Pa.
- **Atmosphere (atm):** Standard atmospheric pressure at sea level  $\approx 101,325$  Pa.
- **Millimeters of Mercury (mmHg):** Used in medical applications; 1 mmHg  $\approx 133.3$  Pa.

### Measurement Devices

- **Manometer:** A device that measures pressure using a column of liquid (e.g., mercury).
- **Barometer:** Measures atmospheric pressure; can be mercury-based or aneroid.
- **Pressure Transducer:** Converts pressure into an electrical signal, widely used in industrial applications.
- **Bourdon Gauge:** A mechanical device used to measure gauge pressure.

### Applications

- **Meteorology:** Weather forecasting and atmospheric studies.
- **Engineering:** Monitoring pressure in systems like pipelines and reactors.
- **Medicine:** Blood pressure measurement using sphygmomanometers.

### Techniques

- **Hydrostatic Pressure:** Relates to the height of a fluid column, often used in liquid measurements.
- **Dynamic Pressure:** Relevant in fluid dynamics, measures the pressure of moving fluids.

If you have specific questions or need more details on a particular aspect, feel free to ask!

## CHAPTER 8 Hydrostatic Forces on Surfaces

Santhiyaa Jenifer

Hydrostatic forces on surfaces arise due to the pressure exerted by a fluid at rest. The pressure increases with depth, and this phenomenon can be analyzed for various surfaces, such as flat, inclined, or curved surfaces submerged in the fluid.

### Key Concepts

#### 1. Hydrostatic Pressure:

- The pressure at a depth  $h$  in a fluid is given by:  $P = \rho g h$  where  $\rho$  is the fluid density,  $g$  is the acceleration due to gravity, and  $h$  is the depth below the fluid surface.

#### 2. Force on a Surface:

- The force  $F$  acting on a submerged surface is calculated by integrating the pressure over the area  $A$ :  $F = \int_A P \, dA = \int_A \rho g h \, dA$
- For a vertical flat surface, the force can be simplified to:  $F = \rho g \int_0^h y \, dA = \rho g \int_0^h y A \, dy$  where  $y$  is the depth from the surface to the differential area  $dA$ .

#### 3. Center of Pressure:

- The point where the total hydrostatic force acts is called the center of pressure. It is located below the centroid of the area due to the increasing pressure with depth.

#### 4. Resultant Force:

- The resultant hydrostatic force can be calculated as:  $F_R = \rho g A_c h_c$  where  $A_c$  is the area of the surface and  $h_c$  is the depth to the centroid of the area.

### Applications

- Dam Design:** Calculating the forces acting on the walls of a dam.
- Ship Stability:** Understanding how submerged surfaces affect buoyancy and stability.
- Hydraulic Structures:** Designing spillways, weirs, and other structures in contact with water.

### Example: Flat Vertical Surface

For a flat vertical wall submerged in water to a depth  $h$ :

#### 1. Force Calculation:

$$F = \int_0^h \rho g y \, dA = \int_0^h \rho g y b \, dy$$

If the wall has a width  $b$ , then:

$$F = \rho g b \int_0^h y \, dy = \rho g b \left[ \frac{y^2}{2} \right]_0^h = \frac{1}{2} \rho g b h^2$$

#### 2. Location of the Center of Pressure:

- The depth  $h_{cp}$  of the center of pressure can be found using:  $h_{cp} = \frac{I_{g,c} + \bar{y}^2 A}{A \bar{y}}$  where  $I_{g,c}$  is the second moment of area about the centroid and  $\bar{y}$  is the depth to the centroid.

## CHAPTER 9

### Types Of Fluid Flow

K.Shanthi

Fluid flow can be categorized into several types based on different criteria. Here are the main types:

#### 1. Based on Flow Characteristics:

- **Laminar Flow:** Smooth, orderly flow where fluid moves in parallel layers. Occurs at low velocities (Reynolds number  $< 2000$ ).
- **Turbulent Flow:** Chaotic, irregular flow with mixing. Occurs at high velocities (Reynolds number  $> 4000$ ).
- **Transitional Flow:** Intermediate flow between laminar and turbulent, typically in the Reynolds number range of 2000 to 4000.

#### 2. Based on Fluid Properties:

- **Newtonian Flow:** Fluid viscosity remains constant regardless of the flow conditions (e.g., water, air).
- **Non-Newtonian Flow:** Fluid viscosity changes with the flow conditions (e.g., ketchup, blood). It can be further classified into:
  - **Shear-thinning (pseudoplastic):** Viscosity decreases with increasing shear rate.
  - **Shear-thickening (dilatant):** Viscosity increases with increasing shear rate.
  - **Bingham Plastic:** Requires a certain yield stress to start flowing (e.g., toothpaste).

#### 3. Based on Flow Direction:

- **Steady Flow:** Flow parameters (velocity, pressure) at a point do not change over time.
- **Unsteady Flow:** Flow parameters change over time.

#### 4. Based on the Flow Path:

- **Uniform Flow:** Velocity at a point remains constant along the flow path.
- **Non-uniform Flow:** Velocity varies from point to point along the flow path.

#### 5. Based on Fluid Behavior:

- **Compressible Flow:** Density changes significantly (e.g., gases at high velocities).
- **Incompressible Flow:** Density changes are negligible (e.g., most liquids).

#### 6. Based on Flow Geometry:

- **Open Channel Flow:** Flow in open channels (rivers, streams).
- **Pipe Flow:** Flow within enclosed conduits (pipes, tubes).

Understanding these types helps in various applications, from engineering to environmental science.

## CHAPTER 10 Bernoulli's Theorem.

R.Devi

Bernoulli's Theorem, also known as Bernoulli's Principle, is a fundamental principle in fluid dynamics. It states that in a streamlined flow of an incompressible, non-viscous fluid, the total mechanical energy along a streamline remains constant. This means that the sum of the pressure energy, kinetic energy per unit volume, and potential energy per unit volume is constant.

Mathematically, it can be expressed as:

$$P + \frac{1}{2} \rho v^2 + \rho gh = \text{constant}$$

Where:

- $P$  = pressure energy per unit volume,
- $\rho$  = fluid density,
- $v$  = fluid velocity,
- $g$  = acceleration due to gravity,
- $h$  = height above a reference level.

### Key Implications:

1. **Velocity and Pressure Relationship:** As the velocity of a fluid increases, its pressure decreases, and vice versa. This explains phenomena like how airplane wings generate lift.
2. **Applications:** Bernoulli's Principle is applied in various fields, including aerodynamics, hydrodynamics, and even in explaining the functioning of devices like Venturi meters and carburetors.

### Assumptions:

- The fluid is incompressible.
- The flow is steady.
- The fluid is non-viscous (ideal fluid).
- The flow is along a streamline.

These assumptions mean that Bernoulli's Theorem is an idealization and may not hold perfectly in real-world applications where viscosity and turbulence play significant roles.

# STRENGTH OF MATERIALS-I



EDITED BY



B.JOSE RAVINDRA RAJ



978-93-6255-696-7



Strength of Materials-I  
Copyright © 2018 by B.JoseRavindra Raj

All rights reserved. No part of this book may be reproduced or transmitted in any form or by any means without written permission from the author.

ISBN: 978-93-6255-696-7

Publisher: PonnaiyahRamajayam Institute of Science and Technology (PRIST)

## TABLE OF CONTENTS

<b>Introduction</b>	<b>-05</b>
<b>CHAPTER 1 - Stress, Strain and Deformation Of Solids</b> Mrs.A.Belciya Mary	<b>-13</b>
<b>CHAPTER 2 -Transfer of Loads And Stresses In Beams</b> Mrs.J.Santhiyaa Jenifer	<b>-27</b>
<b>CHAPTER 3 - Deflection of Beams</b> Mrs.K.Shanthi	<b>-41</b>
<b>CHAPTER 4 - Torsion</b> Mrs.R.Devi	<b>-68</b>
<b>CHAPTER 5-Analysis of Trusses</b> Mr.B.JoseRavindra Raj	<b>-75</b>
<b>CHAPTER 6-Elasticity</b> Mr.DJeyakumar	<b>-88</b>
<b>CHAPTER 7 -Combined stresses</b> Mrs.T.Vidhudhalai	<b>- 112</b>
<b>CHAPTER 8-Solid mechanics</b> Mr.S.Ramakrishnan	<b>-137</b>
<b>CHAPTER 9-Indeterminate frame</b> Mr.D.AmalColins	<b>-151</b>
<b>CHAPTER 10-Understanding material strength, ductility</b> Mrs.M.Karpagam	<b>-162</b>
<b>REFERENCES</b>	<b>-180</b>

# CHAPTER-1

## Stress, Strain and Deformation of Solids

Mrs.A.Belciya Mary

Stress, strain, and deformation are fundamental concepts in the study of solid mechanics, describing how materials respond to applied forces. Here's a breakdown of each concept and their interrelationships:

**Stress: Stress is defined as the internal force experienced by a material per unit area. It represents the intensity of the internal forces acting within a material as a response to external loads.**

### Types of Stress:

#### 1. Normal Stress ( $\sigma$ ):

- Acts perpendicular to the surface. It can be:
  - **Tensile Stress:** When the material is being pulled apart (positive stress).
  - **Compressive Stress:** When the material is being compressed (negative stress).
- Formula:  $\sigma = F/A$
- Where F is the applied force and A is the cross-sectional area.

#### 2. Shear Stress ( $\tau$ ):

- Acts parallel to the surface, causing sliding between adjacent layers.
- Formula:  $\tau = V/A$

Where V is the shear force.

**Strain: Strain is the measure of deformation representing the displacement between particles in a material. It quantifies how much a material deforms in response to stress.**

### Types of Strain:

#### 1. Normal Strain ( $\epsilon$ ):

- Indicates deformation due to normal stress.
- Calculated as the change in length divided by the original length:

$$\epsilon = \Delta L / L_0$$

Where  $\Delta L$  is the change in length and  $L_0$  is the original length.

## Deformation

**Definition:** Deformation is the overall change in shape or size of a body due to applied forces. It encompasses both stress and strain.

### Types of Deformation:

#### 1. Elastic Deformation:

- Temporary deformation that disappears once the load is removed. The material returns to its original shape.
- **Plastic Deformation:** Permanent deformation that occurs when the material is loaded beyond its yield strength. The material does not return to its original shape once the load is removed.

## CHAPTER-2

### Transfer of Loads and Stresses In Beams

Mrs.J.Santhiyaa Jenifer

The transfer of loads and stresses in beams is a fundamental aspect of structural engineering, allowing beams to support various loads while maintaining stability and safety. Here's an overview of how loads are transferred and the resulting stresses in beams.

#### Load Transfer in Beams

1. **Types of Loads:**

- **Point Loads:** Concentrated loads applied at specific points on the beam.
- **Distributed Loads:** Loads spread out over a length of the beam, such as a uniform load.
- **Moment Loads:** Applied moments that cause bending.

2. **Load Path:**

- Loads applied to a beam create internal forces and moments that are transferred through the beam to the supports. The load path follows from the point of application down to the supports.

3. **Reactions at Supports:**

- When a load is applied to a beam, it induces reactions at the supports, which are essential for maintaining equilibrium. The reactions can be vertical, horizontal, or moments, depending on the support type (e.g., fixed, pinned, roller).

#### Beam Theory

1. **Euler-Bernoulli Beam Theory:**

- This classical theory assumes that plane sections remain plane and perpendicular to the beam's neutral axis before and after bending. It provides a foundation for analyzing bending stresses and deflections.

2. **Neutral Axis:**

- The neutral axis is the line within the beam's cross-section where the stress is zero during bending. Above this axis, the material is in compression, and below it, the material is in tension.

3. **Deflection:**

- The deflection of a beam under load can be calculated using various methods, including integration of the bending moment equation or using standard tables for common load cases.
- The shear force can be calculated at any section of the beam, typically being maximum at the supports.

2. **Calculate Shear Stress:**

- Use the shear stress formula to find the shear stress at the relevant section.

# CHAPTER-3

## Deflection of beams

Mrs.K.Shanthi

Deflection of beams is a critical consideration in structural engineering, as it affects the performance, safety, and aesthetic aspects of structures. Deflection refers to the displacement of a beam under applied loads, and understanding how to calculate it is essential for ensuring that beams meet design criteria and serviceability requirements.

### Key Concepts

1. **Elastic Deflection:**
  - When a beam is loaded, it bends, causing a displacement from its original position. This displacement is known as elastic deflection and is temporary, as long as the load does not exceed the yield strength of the material.
2. **Neutral Axis:**
  - The neutral axis is the line within the beam where the stress is zero during bending. Above this line, the material is in compression, and below it, it is in tension.
3. **Types of Deflection:**
  - **Maximum Deflection:** The greatest vertical displacement that occurs in the beam, typically at the midpoint for simply supported beams under uniform loads.
  - **Deflection Shape:** The profile of the beam's displacement due to loading.

### Factors Affecting Deflection

1. **Load Type:** Point loads, uniformly distributed loads, and varying loads each produce different deflection patterns.
2. **Beam Length:** Longer beams tend to deflect more under the same load compared to shorter beams.
3. **Beam Material:** The modulus of elasticity influences how much a beam will deflect; stiffer materials deflect less.
4. **Cross-Sectional Shape:** The moment of inertia of the beam's cross-section affects its resistance to bending.
5. **Support Conditions:** Simply supported, cantilevered, and fixed beams have different deflection characteristics.

### Methods of Analysis

1. **Integration Method:**
  - This involves integrating the bending moment equation to find the relationship between curvature and deflection.
2. **Moment-Area Theorems:**
  - These theorems provide a graphical method for determining deflections by calculating areas and moments.
3. **Virtual Work Method:**
  - This method uses the principle of virtual work to determine deflections based on applied forces and corresponding displacements.
4. **Finite Element Method (FEM):**
  - A numerical method used for complex structures where analytical solutions may be difficult. FEM divides the structure into smaller elements for detailed analysis.

## CHAPTER-4

### Torsion

Mrs.R.Devi

Torsion theory is the study of how materials and structures respond to twisting or torsional forces. It involves understanding the mechanics of torsion, calculating stresses, and predicting deformations in various components, particularly circular shafts. Here's a comprehensive overview of torsion theory:

#### Fundamental Concepts

##### 1. Torque (T):

- The twisting force applied to an object, calculated as:

$$T = F \cdot d$$

Where  $F$  is the force applied and  $d$  is the perpendicular distance from the axis of rotation.

##### 2. Shear Stress ( $\tau$ ):

- When a torque is applied, shear stresses develop within the material. The shear stress at a distance  $r$  from the center of a circular shaft is given by:

$$\tau = \frac{T \cdot r}{J}$$

Where  $J$  is the polar moment of inertia of the shaft's cross-section.

##### 3. Polar Moment of Inertia (J):

- A geometric property of the cross-section that quantifies its resistance to torsion. For a solid circular shaft:

$$J = \frac{\pi d^4}{32}$$

Where  $d$  is the diameter of the shaft.

##### 4. Angle of Twist ( $\theta$ ):

- The angular displacement of one end of the shaft relative to the other due to applied torque. It is calculated using:

$$\theta = \frac{T \cdot L}{G \cdot J}$$

Where  $L$  is the length of the shaft, and  $G$  is the shear modulus of the material.

#### Theories of Torsion

##### 1. Saint-Venant's Theory of Torsion:

- Applies to prismatic bars (uniform cross-section) and assumes that:
  - Plane sections remain plane after deformation.
  - The material behaves elastically up to the yield point.
  - The shear stress distribution is not uniform; it varies with distance from the center.

##### 2. Warping of Shafts:

- In non-circular shafts (e.g., rectangular or I-beams), torsion may cause warping, leading to additional stresses. The effect of warping must be considered in detailed analyses..

# CHAPTER-5

## Analysis of Trusses

B. Jose Ravindra Raj

The analysis of trusses is a fundamental aspect of structural engineering, involving the evaluation of forces within truss members to ensure that the structure can safely support applied loads. Trusses are composed of interconnected straight members that form a framework, typically used in bridges, roofs, and towers. Here's an overview of truss analysis:

### Key Concepts

- 1. Truss Definition:**
  - A truss is a structure made up of triangular units. The members (sides of the triangles) are connected at nodes (joints) and can only carry axial forces (tension or compression).
- 2. Types of Trusses:**
  - **Simple Truss:** A basic truss made of straight members arranged in a triangular pattern.
  - **Compound Truss:** A combination of simple trusses or more complex arrangements.
  - **Pin-Jointed Truss:** Members are connected at joints that allow rotation, ideal for analyzing loads.
- 3. Assumptions in Analysis:**
  - All members are straight and connected at pinned joints.
  - Loads are applied at the joints.
  - Members are either in tension or compression; no bending moments or shear forces are considered.

### Considerations

- 1. Determinate vs. Indeterminate Trusses:**
  - **Determinate Trusses:** Can be solved using static equilibrium alone. The number of members and supports meets the condition for equilibrium.
  - **Indeterminate Trusses:** Require additional information or methods (e.g., compatibility conditions or the use of material properties) for analysis.
- 2. Stability and Strength:**
  - Ensure the truss design meets safety factors and stability requirements, considering possible buckling in compression members.
- 3. Load Types:**
  - Consider different types of loads, including dead loads, live loads, wind loads, and seismic forces, which may act on the truss.

# CHAPTER-6

## Elasticity

D.Jeyakumar

Elasticity is a fundamental property of materials that describes their ability to deform under stress and return to their original shape when the stress is removed. It is a crucial concept in mechanics, materials science, and engineering, impacting how structures and components behave under various loads. Here's a comprehensive overview of elasticity:

### Key Concepts

- 1. Stress and Strain:**
  - **Stress ( $\sigma$ ):** The internal resistance of a material to deformation, defined as force per unit area.
- 2. Hooke's Law:**
  - In the elastic range, stress is proportional to strain:  $\sigma = E \cdot \epsilon$  Where  $E$  is the modulus of elasticity (Young's modulus), a material property that quantifies stiffness.
- 3. Types of Elasticity:**
  - **Linear Elasticity:** The assumption that the relationship between stress and strain is linear, applicable for small deformations.
  - **Non-Linear Elasticity:** The relationship becomes non-linear at higher stresses or strains.
  - **Viscoelasticity:** Materials exhibit both elastic and viscous behaviors, meaning they can show time-dependent strain (e.g., polymers).

### Moduli of Elasticity

- 1. Young's Modulus (E):**
  - A measure of the stiffness of a material, defined as the ratio of tensile stress to tensile strain.
  - High values of  $E$  indicate a stiffer material.
- 2. Shear Modulus (G):**
  - Describes how a material deforms under shear stress

### Elastic Limit and Yield Strength

- **Elastic Limit:** The maximum stress that a material can withstand while still returning to its original shape upon unloading. Beyond this limit, permanent deformation occurs.
- **Yield Strength:** The stress at which a material begins to deform plastically. Once the yield point is surpassed, the material will not return to its original shape.

### Applications of Elasticity

- 1. Structural Engineering:**
  - Elasticity principles are used to analyze beams, columns, and other structural components to ensure they can withstand loads without failing.
- 2. Mechanical Design:**
  - Components such as springs, gears, and shafts are designed based on elastic properties to ensure proper functionality under load.
- 3. Material Science:**
  - Understanding elasticity helps in developing new materials with desirable properties for various applications, such as composites and smart materials.



## CHAPTER-7

### Analytical methods

T.Vidhudhalai

Combined stresses refer to the simultaneous action of different types of stress on a structural member. Typically, these include normal stresses (tensile and compressive) and shear stresses. Understanding combined stresses is crucial for the analysis and design of structural elements that experience multiple loading conditions, such as beams, columns, and shafts.

**Stress: Stress is defined as the internal force experienced by a material per unit area. It represents the intensity of the internal forces acting within a material as a response to external loads.**

#### Types of Stress:

##### 3. Normal Stress ( $\sigma$ ):

- Acts perpendicular to the surface. It can be:
  - **Tensile Stress:** When the material is being pulled apart (positive stress).
  - **Compressive Stress:** When the material is being compressed (negative stress).
- Formula:  $\sigma = F/A$
- Where F is the applied force and A is the cross-sectional area.

##### 4. Shear Stress ( $\tau$ ):

- Acts parallel to the surface, causing sliding between adjacent layers.
- Formula:  $\tau = V/A$

Where V is the shear force.

**Strain: Strain is the measure of deformation representing the displacement between particles in a material. It quantifies how much a material deforms in response to stress.**

#### Types of Strain:

##### 2. Normal Strain ( $\epsilon$ ):

- Indicates deformation due to normal stress.
- Calculated as the change in length divided by the original length:

$$\epsilon = \Delta L / L_0$$

Where  $\Delta L$  is the change in length and  $L_0$  is the original length.

### Deformation

**Definition:** Deformation is the overall change in shape or size of a body due to applied forces. It encompasses both stress and strain.

#### Types of Deformation:

##### 2. Elastic Deformation:

- Temporary deformation that disappears once the load is removed. The material returns to its original shape.
- **Plastic Deformation:** Permanent deformation that occurs when the material is loaded beyond its yield strength. The material does not return to its original shape once the load is removed.

# CHAPTER-8

## Solid mechanics

S.Ramakrishnan

**Solid Mechanics** is a branch of mechanics that deals with the behavior of solid materials under various conditions of loading and boundary constraints. It encompasses the study of stresses, strains, and deformations in materials when subjected to forces, moments, temperature changes, and other environmental factors.

### Key Concepts

#### 1. Stress:

- Stress is defined as the internal force per unit area within materials. It can be classified into several types:
  - **Normal Stress:** Acting perpendicular to the surface (tensile or compressive).
  - **Shear Stress:** Acting parallel to the surface.

#### 2. Strain:

- Strain measures the deformation of a material in response to applied stress. It is the change in length divided by the original length and can be classified as:
  - **Normal Strain:** Change in length per unit length (tensile or compressive).
  - **Shear Strain:** Change in angle (distortion) per unit length.

#### 3. Material Properties:

- Understanding material behavior is crucial in solid mechanics. Key properties include:
  - **Elasticity:** The ability of a material to return to its original shape after the load is removed.
  - **Plasticity:** Permanent deformation that occurs after the yield point.
  - **Ductility:** The ability to deform significantly before fracture.
  - **Brittleness:** The tendency to break without significant deformation.
  - **Hardness:** Resistance to localized plastic deformation.

#### 4. Failure Criteria:

- Various theories predict when a material will fail under load, including:
  - **Maximum Stress Theory**
  - **Maximum Strain Theory**
  - **Von Mises Stress Criterion** (for ductile materials)
  - **Tresca Criterion** (for brittle materials)

#### 5. Deflection:

- The displacement of a structure under load is referred to as deflection. In beams, deflection can be calculated using relationships derived from beam theory, often involving the moment of inertia and modulus of elasticity.

#### 6. Equilibrium and Compatibility:

- Solid mechanics relies on the principles of equilibrium (sum of forces and moments equals zero) and compatibility (deformations must be consistent with the geometry of the structure).

### Applications of Solid Mechanics

#### 1. Structural Engineering:

- Analyzing beams, columns, and frames for load-bearing capacity, stability, and serviceability.

#### 2. Mechanical Design:

- Designing components like gears, shafts, and brackets to ensure they can withstand applied loads without failure.

#### 3. Geotechnical Engineering:

- Understanding soil-structure interaction and stability of foundations and slopes.

# CHAPTER-9

## Indeterminate frame

D.AmalColins

An **indeterminate frame** is a structural system where the number of unknown reactions exceeds the number of equilibrium equations available. This results in a structure that cannot be analyzed using static equilibrium alone. Indeterminate frames are common in engineering because they can provide additional stability and redundancy, making them capable of carrying loads even if some members fail.

### Characteristics of Indeterminate Frames

1. **Redundancy:** Indeterminate frames have more members or supports than necessary for stability. This redundancy allows the structure to maintain its integrity under load even if one or more members are compromised.
2. **Complex Load Distribution:** The internal forces in indeterminate frames are distributed among the members in a way that cannot be determined solely by applying equilibrium equations.
3. **Support Reactions:** The reactions at supports in indeterminate frames cannot be directly calculated without additional analysis because the equilibrium equations are insufficient.

### Types of Indeterminate Frames

1. **Statically Indeterminate:** These structures have more support reactions than can be solved using static equilibrium alone. Examples include continuous beams, multi-span bridges, and frames with redundant supports.
2. **Kinematically Indeterminate:** These structures exhibit more than one possible displacement mode. They can deform in multiple ways under load, such as frames with multiple joints that can rotate.

### Methods of Analysis

To analyze indeterminate frames, several methods can be employed:

1. **Force Methods (Flexibility Method):**
  - This method involves selecting a member or support to remove (creating a statically determinate structure), and then calculating the internal forces and reactions. The flexibility (deformation) of the removed member is then related to the applied loads and constraints.
2. **Displacement Methods (Stiffness Method):**
  - This approach focuses on the displacements and rotations at the nodes of the frame. The stiffness matrix is assembled, and the equations are solved for unknown displacements. From the displacements, internal forces and reactions can be calculated.
3. **Moment Distribution Method:**
  - This iterative method involves distributing moments along the members of the frame and adjusting them based on relative stiffness. It is particularly useful for continuous beams and frames.
4. **Finite Element Method (FEM):**
  - FEM can be used for complex indeterminate frames by discretizing the structure into finite elements, allowing for detailed analysis of stresses, strains, and deformations.

# CHAPTER-10

## Understanding material strength and ductility

M.Karpagam

Understanding material strength and ductility is crucial in materials science and engineering, as these properties determine how materials behave under different loading conditions. Here's an overview of these concepts:

### Material Strength

Material strength refers to the ability of a material to withstand an applied load without failure. It encompasses several aspects:

- Types of Strength:**
  - Compressive Strength:** The maximum compressive (pushing) stress a material can endure.
  - Shear Strength:** The maximum shear stress a material can withstand before failure occurs in a sliding manner.
- Yield Strength:**
  - The stress at which a material begins to deform plastically. Beyond this point, the material will not return to its original shape when the load is removed.
- Ultimate Strength:**
  - The maximum stress a material can withstand before it breaks. This is typically higher than the yield strength.
- Fatigue Strength:**
  - The maximum stress a material can endure for a given number of cycles without failing. Fatigue failure can occur at stresses lower than the material's yield strength.

### Ductility

Ductility is the ability of a material to undergo significant plastic deformation before rupture or failure. It is an important property for materials used in structural applications, allowing them to absorb energy and deform without fracturing.

- Measurement:**
  - Ductility can be quantified using measures such as:
    - Elongation:** The increase in length of a material before failure, usually expressed as a percentage of the original length.
    - Reduction of Area:** The decrease in cross-sectional area at the point of fracture, also expressed as a percentage.
- Importance:**
  - Ductile materials are preferred in applications where they may be subjected to dynamic loads or impacts, as they can deform to dissipate energy.
  - Ductility is critical for safety; ductile materials provide warning signs (deformation) before failure, while brittle materials can fracture suddenly without warning.

### Application

- Construction and Structural Engineering:**
  - Ductile materials (like steel) are used in construction to allow structures to withstand dynamic loads, seismic events, and impacts.

# CONSTRUCTION MATERIALS

EDITED BY

DR.P.PARAMAGURU



978-93-6255-302-7

# **CONSTRUCTION MATERIALS**

Copyright © 2018 by Dr.P.PARAMAGURU

All rights reserved. No part of this book may be reproduced or transmitted in any form or by any means

without written permission from the author.

ISBN: 978-93-6255-302-7

Publisher: Ponnaiyah Ramajayam Institute of Science and Technology (PRIST)

## TABLE OF CONTENTS

<b>CHAPTER 1- STONES – BRICKS – CONCRETE BLOCKS</b>	<b>-05</b>
DR.P.PARAMAGURU	
<b>CHAPTER 2- LIME – CEMENT – AGGREGATES – MORTAR</b>	<b>-10</b>
DR.R.SIVASAMANDY	
<b>CHAPTER -3-CONCRETE</b>	<b>-28</b>
D.JEYA KUMAR	
<b>CHAPTER- 4-TIMBER AND OTHER MATERIALS</b>	<b>-40</b>
B.JOSE RAVINDRA RAJ	
<b>CHAPTER 5-MODERN MATERIALS</b>	<b>-75</b>
A.BELCIYA MARY	
<b>CHAPTER 6-GLASS AND FIBER</b>	<b>-90</b>
B.JOSE RAVINDRA RAJ	
<b>CHAPTER 7-RCC CONCRETE</b>	<b>-110</b>
A.BELCIYA MARY	
<b>CHAPTER 8-COARSE AGGREGATE</b>	<b>-130</b>
D.JEYAKUMAR	
<b>CHAPTER 9-FINE AGGREGATE</b>	<b>-140</b>
B.JOSE RAVINDRA RAJ	
<b>CHAPTER 10- PORTLAND CEMENT</b>	<b>-155</b>
DR.P.PARAMAGURU	
<b>REFERENCES</b>	<b>180</b>

# CHAPTER 1 STONES – BRICKS – CONCRETE BLOCKS

DR.P.PARAMAGURU

Stone has been used in construction for thousands of years due to its durability, strength, and aesthetic qualities. Here are some common types of stone used in construction:

1. **Granite:** Known for its hardness and resistance to abrasion, granite is often used for countertops, flooring, and as a building material for structures like monuments and buildings. It comes in a variety of colors and patterns.
2. **Marble:** Valued for its beauty and elegance, marble is used in high-end interior applications like flooring, countertops, and wall cladding. It's less durable than granite and can be susceptible to scratching and staining.
3. **Limestone:** This sedimentary rock is used in various construction applications, including as a building stone, in cement production, and as a base material for roads. It's relatively easy to work with and comes in colors ranging from white to gray.
4. **Sandstone:** Composed of sand-sized mineral particles or rock fragments, sandstone is often used for building facades, paving, and landscaping. It's available in various colors and textures.
5. **Slate:** Known for its ability to split into thin, durable sheets, slate is used for roofing, flooring, and wall cladding. It has a natural, elegant appearance and is available in various colors.
6. **Basalt:** This dark, volcanic rock is used for construction due to its strength and durability. It's often used for road base material, as well as for certain architectural features.
7. **Travertine:** A type of limestone formed around mineral springs, travertine is often used in flooring, wall cladding, and other decorative applications. It has a distinctive appearance with its natural pits and troughs.

Each type of stone has its own set of properties and benefits, so the choice of stone depends on the specific requirements of the construction project, including factors like load-bearing capacity, weather resistance, and aesthetic preferences.

It sounds like you're asking about the differences between bricks and concrete blocks, or maybe their uses. Here's a quick rundown:

## Bricks:

- **Material:** Typically made from clay or shale that's fired in a kiln.
- **Size:** Generally smaller and more uniform in size, with dimensions usually around 7.5 x 3.5 x 2.25 inches (190 x 90 x 57 mm).
- **Appearance:** Often have a more traditional and aesthetically pleasing look, which makes them popular for visible structures like homes and decorative walls.
- **Strength:** Can be quite strong, especially when used with mortar.
- **Uses:** Ideal for load-bearing walls, fireplaces, and other structures where appearance is important.

## Concrete Blocks:

- **Material:** Made from a mixture of cement, water, and aggregates like sand or gravel.



## CHAPTER 2 LIME – CEMENT – AGGREGATES – MORTAR

DR.R.SIVASAMANDY

It looks like you're listing components related to construction and masonry. Here's a brief overview of each term and how they relate to one another:

1. **Lime:** A material used in construction that can come in different forms, such as quicklime or slaked lime. It's often used to make lime mortar, which is known for its flexibility and breathability.
2. **Cement:** A key binding agent in concrete and mortar. When mixed with water, it hardens and binds other materials together. Common types include Portland cement.
3. **Aggregates:** These are granular materials like sand, gravel, or crushed stone that are mixed with cement and water to make concrete or mortar. They provide bulk and strength to the mix.
4. **Mortar:** A mixture of cement (or lime), sand (a type of aggregate), and water. Mortar is used to bind building materials like bricks or stones together and to fill gaps or joints.

In construction, lime and cement are both used to create mortar, but they have different properties and uses. Lime mortar is often chosen for its workability and historical authenticity, while cement mortar is valued for its strength and durability. Aggregates are mixed with these binding agents to create the final product, whether it's concrete or mortar.

Lime, mortar, and cement are all crucial materials in construction, but they each serve different purposes and have distinct properties. Here's a quick rundown on each:

### Lime

#### Types:

1. **Quicklime (Calcium Oxide):** Produced by heating limestone in a kiln. When water is added, it turns into hydrated lime.
2. **Hydrated Lime (Calcium Hydroxide):** Created by adding water to quicklime, making it a fine, dry powder.

#### Uses:

- **Mortar and Plaster:** Lime is often used in traditional mortars and plasters due to its workability and ability to cure slowly, allowing for better bonding.
- **Soil Stabilization:** Lime can stabilize soil for construction projects.
- **Environmental Benefits:** It's often used in sustainable building practices because it has a lower carbon footprint compared to cement.

#### Properties:

- Lime mortar is flexible and can absorb movement without cracking.
- It has good breathability, which helps with moisture regulation in buildings.

## CHAPTER 3 CONCRETE

D.JEYA KUMAR

Concrete is a fundamental material in construction, known for its durability, versatility, and strength. Here's a brief overview of its key aspects:

1. **Composition:** Concrete is a composite material made up of:
  - **Cement:** Acts as the binder.
  - **Aggregates:** Sand, gravel, or crushed stone provide bulk and strength.
  - **Water:** Reacts with cement to form a paste that binds the aggregates together.
  - **Admixtures:** Optional additives that can modify properties like setting time, workability, or durability.
2. **Mix Design:** The proportions of cement, aggregates, and water are crucial for determining the concrete's properties. Mix designs can vary based on the structural requirements, environmental conditions, and desired finish.
3. **Properties:**
  - **Strength:** Concrete's compressive strength is one of its key features. It is measured in pounds per square inch (psi) or megapascals (MPa).
  - **Durability:** Properly mixed and cured concrete can resist weathering, chemical attacks, and abrasion.
  - **Workability:** Refers to how easily the concrete can be mixed, placed, and finished. Workability can be adjusted with water and admixtures.
4. **Curing:** Proper curing is essential to achieve the desired strength and durability. It involves maintaining adequate moisture and temperature conditions during the initial hardening phase.
5. **Forms and Finishes:** Concrete can be poured into molds (forms) and finished in various ways to achieve different textures and appearances, such as smooth, stamped, or exposed aggregate.
6. **Applications:**
  - **Structural:** Foundations, beams, columns, slabs, and bridges.
  - **Non-structural:** Pavements, walls, and decorative elements.
  - **Specialty:** High-strength concrete, lightweight concrete, self-compacting concrete, etc.
7. **Sustainability:** Innovations in concrete technology include efforts to reduce environmental impact, such as using recycled materials, developing lower-carbon cements, and improving energy efficiency in production.

Concrete remains a versatile and reliable choice for construction due to its adaptability and long-term performance when properly designed and maintained.

## CHAPTER 4 TIMBER AND OTHER MATERIALS

### B.JOSE RAVINDRA RAJ

It sounds like you might be interested in learning about different materials, especially timber and how it compares to others. Timber is a popular building material due to its versatility, sustainability, and aesthetic qualities. It's often used in construction, furniture making, and interior design.

Here's a quick rundown on timber and some other common materials:

#### Timber

- **Types:** Softwoods (e.g., pine, spruce) and hardwoods (e.g., oak, maple).
- **Uses:** Structural elements in buildings, furniture, flooring, and decorative features.
- **Benefits:** Renewable, good insulation properties, and generally easy to work with.
- **Considerations:** Requires proper treatment to prevent issues like rot and insect damage.

#### Metal

- **Types:** Steel, aluminum, copper, etc.
- **Uses:** Structural framework, roofing, and finishes.
- **Benefits:** Strong, durable, and often recyclable.
- **Considerations:** Can be prone to rust and requires different construction techniques.

#### Concrete

- **Types:** Reinforced, pre-stressed, lightweight, etc.
- **Uses:** Foundations, walls, floors, and infrastructure.
- **Benefits:** Very strong and durable, versatile, and fire-resistant.
- **Considerations:** Can be heavy and require significant energy to produce.

#### Brick

- **Types:** Fired clay, concrete, and more.
- **Uses:** Walls, pavements, and decorative elements.
- **Benefits:** Durable, low maintenance, and good thermal mass.
- **Considerations:** Labor-intensive to lay and can be heavy.

#### Glass

- **Types:** Float glass, tempered glass, laminated glass, etc.
- **Uses:** Windows, facades, and interior partitions.
- **Benefits:** Allows natural light, can be aesthetically pleasing, and can be energy-efficient.
- **Considerations:** Fragile and can be costly.

## CHAPTER 5 MODERN MATERIALS

### A.BELCIYA MARY

Modern materials in construction are continually evolving, driven by advancements in technology, sustainability goals, and the need for improved performance. Here are some notable examples of modern materials used in construction today:

1. **High-Performance Concrete:**
  - **Self-Healing Concrete:** Contains bacteria or chemicals that react with water to fill cracks as they form.
  - **Ultra-High-Performance Concrete (UHPC):** Offers exceptional strength, durability, and aesthetic options due to its dense mix.
2. **Advanced Insulation Materials:**
  - **Aerogel:** Known for its extremely low thermal conductivity, aerogel provides excellent insulation.
  - **Vacuum Insulation Panels (VIPs):** Offer superior insulation properties by creating a vacuum within a panel.
3. **Smart Materials:**
  - **Shape-Memory Alloys (SMAs):** Metals that return to their original shape after deformation when exposed to certain stimuli (e.g., temperature changes).
  - **Phase-Change Materials (PCMs):** Materials that absorb or release heat during phase transitions, helping to regulate building temperatures.
4. **Sustainable and Eco-Friendly Materials:**
  - **Bamboo:** A rapidly renewable resource with high strength-to-weight ratio, used in structural and decorative applications.
  - **Recycled and Upcycled Materials:** Includes recycled steel, glass, and reclaimed wood, reducing waste and the environmental impact.
5. **Advanced Roofing Materials:**
  - **Cool Roofing:** Reflective materials that reduce heat absorption and lower cooling costs.
  - **Green Roof Systems:** Incorporate vegetation to provide insulation, reduce stormwater runoff, and improve urban biodiversity.
6. **Innovative Structural Materials:**
  - **Cross-Laminated Timber (CLT):** Engineered wood panels that are strong, lightweight, and provide an alternative to traditional concrete and steel.
  - **Fiber-Reinforced Polymers (FRPs):** Composites that offer high strength-to-weight ratios and resistance to corrosion.
7. **Energy-Efficient Glazing:**
  - **Low-E Glass:** Coated to reflect infrared light and reduce heat transfer, improving energy efficiency.
  - **Electrochromic Glass:** Allows users to adjust the tint of the glass to control light and heat transmission.

## CHAPTER 6 GLASS AND FIBER

### B. JOSE RAVINDRA RAJ

Glass and fiber materials are increasingly popular in modern construction due to their unique properties and advantages. Here's an overview of how they are used:

#### Glass in Construction

1. **Architectural Design:** Glass is often used for aesthetic purposes in modern architecture, allowing for expansive views, natural light, and sleek, contemporary designs.
2. **Structural Glass:** High-strength glass can be used as a structural element, such as in glass floors, walls, and facades. This type of glass includes laminated glass and tempered glass.
3. **Insulation and Energy Efficiency:** Insulated glass units (IGUs) improve energy efficiency by reducing heat loss and gain. They consist of two or more panes of glass separated by an air or gas-filled space.
4. **Safety and Security:** Laminated and tempered glass are used in safety applications. Laminated glass has a plastic interlayer that holds shards together in case of breakage, while tempered glass is heat-treated to increase strength and shatter into small, less dangerous pieces.
5. **Green Building:** Glass can be part of sustainable building practices. For example, low-emissivity (low-e) glass reduces the amount of UV and infrared light that passes through without compromising on natural light, helping to reduce energy consumption.

#### Fiber in Construction

1. **Fiber-Reinforced Concrete:** Fibers, such as steel, glass, or synthetic fibers, are added to concrete to improve its mechanical properties. This type of concrete enhances strength, durability, and crack resistance.
2. **Fiber-Reinforced Polymer (FRP):** FRP composites are used for strengthening existing structures or for new construction. They are lightweight, corrosion-resistant, and have high strength-to-weight ratios, making them ideal for reinforcing beams, columns, and slabs.
3. **Insulation:** Fiberglass insulation is commonly used in building envelopes to improve thermal resistance and reduce energy consumption. It's also fire-resistant and helps with soundproofing.
4. **Geotextiles:** Synthetic fibers are used in geotextiles for soil stabilization, drainage, and erosion control. These materials help to reinforce soil, prevent erosion, and improve drainage in civil engineering projects.
5. **Sustainable Practices:** Many fiber-based materials are recyclable or made from recycled content, contributing to sustainable construction practices. For example, some fiber-reinforced composites use recycled plastics.
- 6.
7. recycled plastics.

## CHAPTER 7 RCC CONCRETE

### A.BELCIYA MARY

Reinforced Cement Concrete (RCC) is a crucial material in modern construction due to its strength, durability, and versatility. Here's a breakdown of its key aspects:

#### What is RCC?

RCC is a composite material that combines the tensile strength of steel reinforcement with the compressive strength of concrete. It typically consists of:

- **Concrete:** Made from cement, water, and aggregates (sand, gravel, or crushed stone).
- **Steel Reinforcement:** Usually in the form of rebar or mesh, providing tensile strength and crack control.

#### Benefits of RCC:

1. **Strength and Durability:** RCC structures are robust and can withstand heavy loads and environmental stresses.
2. **Flexibility in Design:** It can be molded into various shapes and sizes, making it suitable for a wide range of architectural and structural applications.
3. **Fire Resistance:** Concrete has good fire resistance properties, enhancing the safety of structures.
4. **Low Maintenance:** Once set, RCC structures require minimal maintenance.

#### Applications in Construction:

1. **Buildings:** Used in foundations, columns, beams, slabs, and walls.
2. **Bridges:** Provides the strength needed for spanning long distances and supporting heavy loads.
3. **Pavements and Roads:** RCC pavements are durable and suitable for high-traffic areas.
4. **Dams and Water Tanks:** Its resistance to water makes it ideal for these structures.

#### Key Considerations:

1. **Mix Proportions:** The ratio of cement, water, and aggregates affects the strength and durability of the concrete.
2. **Quality Control:** Ensuring proper mixing, curing, and placement is essential for achieving desired properties.
3. **Reinforcement Placement:** Correct placement of steel reinforcements is critical to maximize the benefits of RCC.

## CHAPTER 8 COARSE AGGREGATE

D.JEYAKUMAR

Coarse aggregate is a fundamental component in construction, particularly in concrete production. Here's a quick rundown of its role and characteristics:

### What is Coarse Aggregate?

Coarse aggregate consists of larger particles used in construction. These aggregates generally have a size greater than 4.75 mm (about 0.2 inches) and can include materials like gravel, crushed stone, or recycled concrete.

### Functions in Construction

1. **Concrete Mixes:** Coarse aggregates provide strength and bulk to concrete mixes. They help reduce the cost of the concrete by replacing a portion of the cement with less expensive materials.
2. **Load-Bearing:** In structural applications, coarse aggregates help in distributing loads and stresses, thereby contributing to the stability and durability of the construction.
3. **Volume Stability:** They provide volume stability and reduce shrinkage during the curing process of concrete.

### Types of Coarse Aggregate

1. **Gravel:** Natural gravel is often rounded and smooth. It's typically used in concrete mix designs where the aesthetic and performance characteristics are a priority.
2. **Crushed Stone:** This is stone that's been mechanically broken down and usually has sharp edges. It's preferred for its angularity which helps in bonding with the cement paste.
3. **Recycled Aggregate:** Made from crushed concrete or asphalt, this type of aggregate is environmentally friendly and can be used in various construction applications.

### Selection Criteria

1. **Size:** The size of the aggregate affects the strength and workability of the concrete. Common sizes are 10 mm, 20 mm, and 40 mm.
2. **Shape:** Angular aggregates generally provide better interlocking and bonding properties compared to rounded ones.
3. **Strength:** Aggregates must be strong enough to withstand the loads they will encounter without breaking down.
4. **Cleanliness:** Aggregates should be free from impurities like clay, silt, and organic material, which can affect the quality of the concrete.
5. **Absorption and Specific Gravity:** These properties affect the mix design and the amount of water needed in the concrete mix.

## CHAPTER 9 FINE AGGREGATE

### B.JOSE RAVINDRA RAJ

Fine aggregate is a crucial material in construction, typically consisting of sand or crushed stone with particles smaller than 4.75 mm (about 0.2 inches). It plays several key roles in concrete and mortar:

1. **Improves Workability:** Fine aggregate helps to fill the voids between coarse aggregates, making the concrete or mortar mixture more workable and easier to place.
2. **Enhances Strength:** It contributes to the overall strength of concrete by providing a smooth surface for the cement paste to bond with, helping to achieve a dense and strong final product.
3. **Reduces Shrinkage:** Properly graded fine aggregate helps reduce the risk of cracking due to shrinkage as it helps create a more uniform mixture.
4. **Economic Benefits:** Fine aggregates are often less expensive than coarse aggregates, so using them efficiently can help reduce overall material costs.
5. **Aesthetic Qualities:** In decorative concrete and other applications, fine aggregate can influence the surface texture and appearance.

#### Common Types of Fine Aggregate:

- **Natural Sand:** Sourced from riverbeds, dunes, or coastal areas. It's usually preferred for its uniformity and smooth texture.
- **Crushed Stone Sand:** Produced by crushing larger stones, this type can be more angular and may affect the texture of the final product.
- **Manufactured Sand:** Created by crushing rocks, this is often used as a substitute for natural sand when supplies are limited.

#### Key Properties to Consider:

- **Grain Size Distribution:** A well-graded aggregate provides better workability and strength.
- **Shape and Texture:** Rounded particles generally produce a smoother mixture, while angular particles can increase strength but might reduce workability.
- **Absorption and Moisture Content:** These factors influence the amount of water needed in the mix.

In construction, the choice of fine aggregate can impact the performance, durability, and aesthetics of the final structure.



# CHAPTER 10 PORTLAND CEMENT

Dr.P.PARAMAGURU

Portland cement is a key ingredient in modern construction, widely used in a variety of concrete and masonry applications. Here's a breakdown of its role and importance:

## 1. What is Portland Cement?

Portland cement is a type of hydraulic cement, meaning it hardens through a chemical reaction with water. It is made by finely grinding clinker, a mixture of limestone and other materials, and then heating it to high temperatures in a kiln.

## 2. Types of Portland Cement:

- **Type I:** General-purpose cement suitable for most construction applications.
- **Type II:** Offers moderate resistance to sulfate attack and is used in structures exposed to soil or water with moderate sulfate concentrations.
- **Type III:** High early strength cement that gains strength quickly, making it ideal for fast-track projects.
- **Type IV:** Low heat of hydration cement used for massive structures like dams to reduce the heat generated by hydration.
- **Type V:** High sulfate-resistant cement used in environments with high sulfate exposure.

## 3. Applications:

- **Concrete:** Portland cement is the primary binding agent in concrete, which is used for foundations, pavements, bridges, and buildings.
- **Masonry:** It is used in mortar for laying bricks and blocks, providing strength and durability.
- **Plaster and Stucco:** Cement is also a key component in plaster and stucco, used for finishing and decorating walls.

## 4. Advantages:

- **Strength:** Concrete made with Portland cement is strong and durable, capable of supporting heavy loads.
- **Versatility:** It can be used for a wide range of construction needs, from small residential projects to large infrastructure works.
- **Workability:** It can be molded into various shapes and sizes before setting, allowing for creative and complex designs.

## 5. Considerations:

- **Environmental Impact:** The production of Portland cement is energy-intensive and generates significant CO2 emissions. Efforts are being made to develop more sustainable alternatives and improve production processes.
- **Setting Time:** Different types of Portland cement have varying setting times, which can be critical depending on the project requirements.



# DIGITAL MARKETING

*Edited by*

**DR. S. POUGAJENDY**



978-93-6255-600-4

DIGITAL MARKETING

Copyright © 2018 by Dr. S. POUGAJENDY

All rights reserved. No part of this book may be reproduced or transmitted in any form or by any means without written permission from the author.

ISBN: 978-93-6255-600-4

Publisher: Ponnaiyah Ramajayam Institute of science and Technology  
(PRIST)

## **TABLE OF CONTENTS**

CHAPTER 1 Introduction to Digital Marketing .....	1
DR. S. VENKATESH	
CHAPTER 2 Content of Digital Marketing Laws .....	15
DR. P. BALASUBRAMANIAN	
CHAPTER 3 Your Digital Marketing Strategy Template (AKA The Customer Value Journey) .....	21
DR. K. RAJALAKSHMI	
CHAPTER 4 Social Media Marketing .....	32
DR. R. PREMA	
CHAPTER 5 Online Reputation Management.....	40
MRS. P. UMA ESWARI	
CHAPTER 6 Developing a Content Marketing Strategy .....	49
DR. T. J. JAYASHOLAN	
CHAPTER 7: Designing Your Search Marketing Strategy.....	58
Dr. K. G. SELVAN	
CHAPTER 8 Crafting a Digital Advertising Plan.....	71
MR. K. SASIKUMAR	
CHAPTER 9 Following Email Marketing Best practices.....	86
DR. P. BALASUBRAMANIAN	
CHAPTER 10 Developing a Social Media Strategy.....	97
MR. K. SASIKUMAR	

# **CHAPTER 1**

## **Introduction to Digital Marketing**

**DR. S. VENKATESH**

*Department of Management,*

**Ponnaiyah Ramajayam Institute of science and Technology(PRIST)**

Digital marketing is the use of digital technologies and platforms to promote products and services, as well as to connect with potential customers. It is an incredibly versatile and powerful tool that can be used in various ways to reach people worldwide. Digital marketing utilizes multiple digital technologies to deliver promotional messages, such as mobile phones, computers, and other digital media and platforms. It can be used for B2B (Business to Business) and B2C (Business to Consumer) marketing, depending on the goal and objectives of the campaign. Digital marketing offers unique advantages such as greater reach, improved targeting, personalized messaging, and better ROI (Return on Investment). It also allows businesses to stay up-to-date with marketing trends and technologies. With the right strategies and tactics, companies can leverage digital marketing to increase their visibility and reach a larger audience.

### **Some Facts on Digital Marketing**

Digital marketing has become a popular way of reaching out to potential customers, as it is efficient, cost-effective and provides more control over the targeting of advertisements. Digital marketing channels such as search engine optimization (SEO), pay-per-click (PPC), social media marketing (SMM) and email marketing are used to create and deliver marketing messages, as well as measure the success of campaigns.

Some key facts on digital marketing include the following:

- Compared to \$491.70 billion in 2021, the amount spent on digital advertising in 2022 increased by 16.2%.

## **CHAPTER 2**

### **Content of Digital Marketing Laws**

**DR. P. BALASUBRAMANIAN,**  
*Department of Management,*  
**Ponnaiyah Ramajayam Institute of science and Technology(PRIST)**

#### Digital Marketing

Digital marketing typically refers to online marketing campaigns that appear on a computer, phone, tablet, or other device. It can take many forms, including online video, display ads, search engine marketing, paid social ads and social media posts. Digital marketing is often compared to “traditional marketing” such as magazine ads, billboards, and direct mail. Oddly, television is usually lumped in with traditional marketing.

Did you know that more than 3 quarters of Americans go online on a daily basis? Not only that, but 43% go on more than once a day and 26% are online “almost constantly.”

These figures are even higher among mobile internet users. 89% of Americans go online at least daily, and 31% are online almost constantly. As a marketer, it’s important to take advantage of the digital world with an online advertising presence, by building a brand, providing a great customer experience that also brings more potential customers and more, with a digital strategy.

A digital marketing strategy allows you to leverage different digital channels—such as social media, pay-per-click, search engine optimization, and email marketing—to connect with existing customers and individuals interested in your products or services. As a result, you can build a brand, provide a great customer experience, bring in potential customers, and more.

## **CHAPTER 3**

### **Your Digital Marketing Strategy Template (AKA The Customer Value Journey)**

**DR. K. RAJALAKSHMI ,**  
*Department of Management,*  
**Ponnaiyah Ramajayam Institute of science and Technology(PRIST)**

This is where digital marketing begins and ends... With a Customer Value Journey that strategically builds relationship with new prospects and converts them into loyal, repeat customers. This Journey is the process every prospect goes through to become a new customer. It's how strangers become buyers and, eventually, raving fans of your business. The hard truth is that marketing is not a one-step process. There are eight stages you must account for on the path to purchase and promotion. But, I have great news. If you understand this digital marketing strategy (a.k.a. the Customer Value Journey), then you can intentionally engineer your business in such a way that it moves people predictably through the stages in this template. In other words, you'll no longer wonder if you'll be able to generate leads. You won't have to cross your fingers and hope for customers. When you understand the Customer Value Journey, even reviews and referrals will become automatic. The Customer Value Journey is the strategic foundation of everything we do here at DigitalMarketer. It's the master template upon which every other digital marketing discipline and tactic is built. It's so important, we confidently make this bold statement: The job of marketing is to move prospects and customers seamlessly and subtly through each phase of the Customer Value Journey. In this chapter, we'll start with a high-level map of the Customer Value Journey. Then we'll dive into each of the 8 steps, talk about the tactics you'll need to move people along the Journey, and review case studies so

## CHAPTER 4

### Social Media Marketing

**DR. R. PREMA,**  
*Department of Management,*  
**Ponnaiyah Ramajayam Institute of science and Technology(PRIST)**

What Is Social Media Marketing (SMM)?

Social media marketing (also known as digital marketing and e-marketing) is the use of social media—the platforms on which users build social networks and share information—to build a company's brand, increase sales, and drive website traffic. In addition to providing companies with a way to engage with existing customers and reach new ones, SMM has purpose-built data analytics that allows marketers to track the success of their efforts and identify even more ways to engage.

Within 18 years, from 2004 (when MySpace became the first social media site to reach one million users) to 2022, the dramatic growth of interactive digital channels took social media to levels that challenge even the reach of television and radio.<sup>1</sup> At the start of 2023, there were 4.76 billion social media users globally—over 59% of the world's population.<sup>2</sup>

#### KEY TAKEAWAYS

- Social media marketing uses social media and social networks—like Facebook, X (formerly Twitter), and Instagram—to market products and services, engage with existing customers, and reach new ones.
- The power of social media marketing comes from the unparalleled capacity of social media in three core marketing areas: connection, interaction, and customer data.
- Social media marketing has transformed the way businesses can influence consumer behavior—from promoting content that drives engagement to extracting personal data that makes messaging resonate with users.



## CHAPTER 5 Online Reputation Management

MRS. P. UMA ESWARI,  
*Department of Management,*  
Ponnaiyah Ramajayam Institute of science and Technology(PRIST)

### What Is Reputation Management in Digital Marketing?

Reputation management in digital marketing is the practice of monitoring and managing a brand's image using online tactics. Reputation monitoring allows digital marketing agencies to get a strong grasp of how current and potential customers view a brand. Managing a brand's reputation is an important aspect of digital marketing that can improve its image to its customers.

Reputation management in digital marketing usually involves monitoring and managing several key media categories for a brand:

- **Owned media** refers to a brand's own website, social media, and blog. Monitoring these gives a digital marketing agency a baseline understanding of how customers interact with information put out by the brand itself.
- **Earned media** is the collection of coverage or mentions that a brand has earned on other websites, blogs, or forums. This category also includes reviews on sites like TrustPilot, GlassDoor, or even Google business listings. Many customers will do a small amount of research before they purchase from a brand, so understanding what they will read about your brand when they perform a search on these sites is critical.
- Monitoring **shared media** involves social listening, which is the practice of keeping tabs on what people are saying about your brand on social media, whether from other businesses' accounts or personal accounts.

## CHAPTER 6

### Developing a Content Marketing Strategy

**DR. T. J. JAYASHOLAN,**  
*Department of Management,*  
**Ponnaiyah Ramajayam Institute of science and Technology(PRIST)**

It's a big promise: perfect content marketing. But it is possible if you understand how content fits into your overall digital marketing strategy. And done right, your content marketing will not only attract prospects, but also move them through a marketing funnel to drive more sales and grow your business.

In this chapter, we cover the basics of a successful content marketing program, including methods and metrics, the business roles that should own your content marketing, and the lingo you'll use to talk about it.

#### Methods of Well-Executed Content Marketing

Let's start with a thorough understanding of what we mean when we say content. You see, most businesses miss out on a lot of opportunities because their vision for content marketing is too small. As a result, they're churning out content but not getting great results. And here's why: content in and of itself isn't what drives traffic and sales.

Your content needs to be "perfect."

Now, what do we mean by that?

Perfect content isn't about you, your brand, or your objectives. It's about delivering the right information to your prospects at exactly the right point in the customer journey.

Developing a Content Marketing Strategy 41 For instance, for the software

## **CHAPTER 7**

### **Designing Your Search Marketing Strategy**

**DR. K. G. SELVAN,**  
*Department of Management,*  
**Ponnaiyah Ramajayam Institute of science and Technology(PRIST)**

Algorithm updates. Semantic markup. Search intent.

One thing's for sure: search marketing ain't what it used to be!

Luckily, all these changes are good news for digital marketers like us. Because we're not trying to game the system... And when you're an honest marketer trying to deliver real value, you're building a solid foundation for search marketing success. That being the case, search marketing can help you boost your website's traffic and visitors' trust while supporting your other digital marketing disciplines too.

In this chapter, you'll get an overview of the methods that are working now, including the lingo you'll use to talk about it, the metrics that will measure your success, and the business roles that should own your search marketing strategy. Before we dig into the details, though, let's cover a few foundational principles.

The Big Picture:

First, SEO is a broad field divided into 2 big camps. 1. The structural, or technical, side. People in this camp focus on the technical details of your website rather than the quality of your content. 2. The content side of things. People in this camp know how to create well-optimized content, build links, and boost social shares. Which camp is best?

There's no contest. To succeed at search marketing, you need both. When you need to create link assets or get more backlinks, you need an SEO content specialist. But if Google doesn't seem to see those assets, and

## **CHAPTER 8**

### **Crafting a Digital Advertising Plan**

**MR. K. SASIKUMAR,**  
*Department of Management,*  
**Ponnaiyah Ramajayam Institute of science and Technology(PRIST)**

One of our biggest challenges as digital marketers is traffic.

How can we easily and affordably get people's attention, push them to our websites, and convert them to subscribers and customers? The secret is digital advertising. And if you understand how to make it work, it can give you full control over your traffic flow and help you sell more too.

In this chapter, you'll learn the process for planning, setting up, and optimizing your ads, including the metrics you need to watch, the lingo you'll use as a media buyer, and the people in your business who should be responsible for digital advertising. But before we start, let's get clear about why paid traffic is a smarter investment than organic.

#### **The Difference Between Paid and Organic Traffic**

Free traffic is always the goal, right? Which is why most businesses aim for organic traffic first. After all, if you can get a steady flow of free traffic, you'll pocket the savings. But as with everything else in life, you get what you pay for. The easiest way to explain that is with a simple comparison: the water hose versus the rain. Paid traffic is like a water hose. You have complete control over the direction it's pointed, the amount of water pouring from it, and how long you let the water flow. You can turn it on and off whenever you want. If you're getting more traffic than you need, with paid traffic, you can slow the flow. You have control of where it's going, how fast, and when.

Organic traffic, on the other hand, is more like rain. You aren't sure when or if it will come, how consistent it will be, nor how long it will last. Listen

## **CHAPTER 9**

### **Following Email Marketing Best practices**

**P. BALASUBRAMANIAN,**  
*Department of Management,*  
**Ponnaiyah Ramajayam Institute of science and Technology(PRIST)**

After reading the last chapter, we're confident you understand that we live in a social world. Your own experience probably backs that up. Every day, you chat in real-time with people all over the world. Does that spell the end of email marketing? As social media has grown in importance, many so-called marketing experts have predicted the end of email. Don't believe them! Email marketing is alive and well. And here's why we say that with the utmost confidence: • Traffic and Conversion Summit launched in 2009 with 258 attendees. Email marketing was a big part of the launch strategy.

- Using email marketing to promote the event, T&C grew to 4,500 attendees in just 8 years.
- In only one year, Digital Marketer generated well over \$20 million in revenue from email marketing alone. Regardless of the rumors, email is nowhere near "dead"—and if you know how to use it, it will help you exponentially grow your business. With that in mind, in this chapter, we'll review the basics of email marketing, including the methods, the metrics, the lingo you need to know, and who on your team should own email marketing. But first, let's look at the role email plays in a growing business.

After reading the last chapter, we're confident you understand that we live in a social world. Your own experience probably backs that up. Every day, you chat in real-time with people all over the world. Does that spell the end of email marketing? As social media has grown in importance, many

## **CHAPTER 10**

### **Developing a Social Media Strategy**

**MR. K. SASIKUMAR,**  
*Department of Management,*  
**Ponnaiyah Ramajayam Institute of science and Technology(PRIST)**

If marketing is about putting your message where your audience hangs out (which it is), then social media is a no brainer. That said, many businesses fail to fully leverage social media in their marketing plans. They dabble, sure, but their strategic efforts end with content and advertising. That's a big mistake, and here's why... Today, 79% of US internet users are on Facebook. Six out of ten Americans stay updated on news through social media, while 35% have used social media to look for or research a job. And these same numbers are reflected worldwide. Is it any wonder marketers are going social to grow their business?

Trouble is that "going social" isn't as easy as it looks. There's a lot more to social media marketing than simply posting to Facebook and Twitter. In this chapter, we cover the basics of a successful social media program, including methods and metrics, the business roles that should own your social media marketing, and the lingo you'll use to talk about it. Keep in mind, there's a big difference between a social media manager and a community manager. (Yes, both manage social media efforts, but their focus is different.) Learn more in our article, [Social Media Manager vs. Community Manager. Methods of Well-Executed Social Media Marketing](#)

There are 4 stages in a successful social cycle:

- Listening
- Influencing
- Networking
- Selling



# **LEADERSHIP AND MANAGEMENT SKILLS**

EDITED BY

**DR. K. RAJALAKSHMI**



**978-93-6255-342-3**

# LEADERSHIP AND CHANGE MANAGEMENT

Copyright © 2018 by Dr. K. RAJALAKSHMI

All rights reserved. No part of this book may be reproduced or transmitted in any form or by any means without written permission from the author.

ISBN: 978-93-6255-342-3

Publisher: Ponnaiyah Ramajayam Institute of science and Technology  
(PRIST)



## TABLE OF CONTENTS

CHAPTER 1 Introduction to Leadership .....	1
MR. K. SASIKUMAR	
CHAPTER 2 Theories of Leadership .....	15
DR. P. BALASUBRAMANIAN	
CHAPTER 3 Leadership and Management .....	21
DR. S. POUGAJENDY	
CHAPTER 4 Art of Giving Feedback .....	32
DR. R. PREMA	
CHAPTER 5 Emotional Intelligence.....	40
MRS. P. UMA ESWARI	
CHAPTER 6 Problem Solving and Decision Making .....	49
DR. T. J. JAYASHOLAN	
CHAPTER 7: Creating Women Business Leaders.....	58
Dr. K. G. SELVAN	
CHAPTER 8 Change Management.....	71
DR. S. VENKATESH	
CHAPTER 9 Organization Development Intervention.....	86
DR. P. BALASUBRAMANIAN	
CHAPTER 10 Resistance to Change.....	97
MR. K. SASIKUMAR	

# **CHAPTER 1**

## **Introduction to Leadership**

**MR. K. SASIKUMAR**

**Department of Management**

**Ponnaiyah Ramajayam Institute of science and Technology(PRIST)**

Several community-initiated projects have come to a grinding halt owing to lack of leadership and other management skills. Many local leaders, with best of intentions for solving environmental problems in their community, initiate a project only to see it fail through poor leadership. Sometimes they have an outdated philosophy of management which does not fit comfortably with volunteer members of government and non-government agencies. As people become better educated they become more articulate and no longer respond to authoritative styles of leadership in every situation.

### **Understanding Leadership**

Leaders perform various roles such as planning and implementing, evaluating, monitoring, controlling, motivating, managing conflicts, organizing task groups, mobilizing human and financial resources, and above all, setting an example to the group.

We recognize that leadership is necessary for efficiency, but because of our egalitarian tradition, we are uncomfortable with any suggestion of superiority.

There are a number of major theories about leadership. Each theory focuses on a different aspect of human behaviour, and provides useful insights into what makes a good leader.

Leadership is sometimes viewed as headship, as in a formal position such as that of chairperson, director, or politician. A person who lacks leadership skills may still be appointed to such a position. In due course, this person may be replaced by new leaders if he/she does not learn to exercise the functions of leadership in

## **CHAPTER 2**

### **Theories of Leadership**

**DR. P. BALASUBRAMANIAN**  
**Department of Management**  
**Ponnaiyah Ramajayam Institute of science and Technology(PRIST)**

A brief summary of the important theories on leadership is given below, to provide an understanding of leadership behaviour.

#### **Trait Theory (Great Man Theory)**

According to this school of thought, leadership is rooted in biology. Some of those who support the trait theory believe that leaders are born, not made, while others take the view that everyone can lead, but he or she will lead differently.

The trait approach basically states that you either have it or you don't, and the "right" person will be selected to fill formal positions. Some behavioural scientists however, have focused more on the behaviour of effective leaders. May be there is something unique about leadership behaviour, e.g. is it more democratic than autocratic? This approach has been seen as more useful than the trait theory as it may provide more definitive answers on effective leadership, and suggests that people can be trained as leaders.

#### **Contingency Theories**

(Leadership dependent or contingent on many factors)

Two major approaches stem from contingency theory — that of styles and roles, and that of situational leadership.

**The Styles and Roles Approach:** This approach analyses the leadership roles and behavioural styles of successful leaders. It acknowledges that group situations are often different, and emphasizes the need for flexibility in styles and roles. A person must play many roles and employ different styles in order to be an effective leader.

The leadership function moves around in a group depending upon who is doing what. For example, one person might lead in the initiation of a group task. Another may assume leadership by offering information. Yet another member may move into the lead by including everyone in the discussion. Leadership is dynamic and situational, requiring different skills and knowledge as a group progresses towards its goals.

Some researchers have identified five major leadership roles: the Activator, the Controller, the Martyr, the Cavalier and the Abdicator. These roles can be described with regard to the degree of flexibility and of activity they exhibit.

The leadership function moves around in a group depending upon who is doing what. For example, one person might lead in the initiation of a group task. Another may assume leadership

## **CHAPTER 3**

### **Leadership and Management**

**DR. S. POUGAJENDY**

**Department of Management**

**Ponnaiyah Ramajayam Institute of science and Technology(PRIST)**

There are at least seven distinct roles concerned with the exercise of power and influence in organizations

1. Political office holder, eg. Government minister or town mayor. The legitimacy of the authority vested in this role in a democratic society derives from the ballot box. Acceptance of such authority is for the most part willingly given but in the last resort is enforced by the courts. In a democratic society there are safeguards to prevent arbitrary exercise of power associated with holding a political office or using that power in a self-interested way.
2. Commander: A role confined to military or paramilitary organizations, its legitimacy stems from the nature of the threats to society, which the organization exists to deal with, such as the exigencies of war. The commander's orders are backed by the sanctions of stern discipline. Command is not necessarily perfectly correlated with rank. For example, the captain of a ship or an aircraft is in command although he may be junior in rank to another officer who may be acting as a member of the crew or in an advisory role.
3. Administrator or bureaucrat (in the positive, Weberian sense). This is the traditional public service role which derives the legitimacy of its authority from a rational/legal set of rules and regulations and from holding of an office with defined powers within a structure of authority and control. Challenges to the rules are rare but when they occur the response is procedural and measured. Administrators are judged by their ability to maintain order, stability, uniformity of treatment and impartiality.

## **CHAPTER 4**

### **Art of Giving feedback**

**DR. R. PREMA**

**Department of Management**

**Ponnaiyah Ramajayam Institute of science and Technology(PRIST)**

#### Feedback and Learning from Experience

Learning from experience and feedback is a great quality for anyone to have. Enterprising managers possess this quality. They are continuously modifying their goal-setting behaviour on the basis of the feedback they receive from their environment. For example, in a toy assembling game, if a manager undertakes to assemble a certain number of toys and cannot do it, he modifies his goal in the next trail using the results of his previous experience. He has an orientation and flexibility of mind to test out his capabilities whenever an opportunity arises and is open to feedback.

#### Art of giving feedback

##### Feedback of Observations

- Feedback, intended to help a person or a group to develop, has to be acceptable and has to be useable. Otherwise, despite the best of intentions, it is wasted.
- Given in the right manner, feedback wins support and reinforces the desire to improve. Badly done, it will provoke resentment and rejection.
- Identifiable details help the recipient to recognize the precise circumstances being referred to, whereas sweeping generalisations present a confused picture and open the way to

## **CHAPTER 5**

### **Emotional Intelligence**

**MRS. P. UMA ESWARI**

**Department of Management**

**Ponnaiyah Ramajayam Institute of science and Technology(PRIST)**

It was Daniel Goleman who first brought the term “emotional intelligence” to a wide audience in 1995 book of that name, and it was Goleman who first applied the concept to business in 1998. In his research at nearly 200 large, global companies, Goleman found that while the qualities traditionally associated with leadership - such as intelligence, toughness, determination, and vision - are required for success, they are insufficient. Truly effective leaders are also distinguished by a high degree of emotional intelligence, which includes self-awareness, self-regulation, motivation, empathy, and social skills.

These qualities may sound “soft” and un-business like, but Goleman found direct ties between emotional intelligence and measurable business results. While emotional intelligence’s relevance to business has continued to spark debate over the past six years, Goleman’s article remains the definitive reference on the subject, with a description of each component of emotional intelligence and a detailed discussion of how to recognize it in potential leaders, how and why it connects to performance, and how it can be learned.

Such anecdotes support the widespread belief that identifying individuals with the “right stuff” to be leaders is more art than science. After all, the personal styles of superb leaders vary: Some leaders are subdued and analytical; others shout their manifestos from the mountain tops. And just as important, different situations call for different types of leadership. Most mergers need a sensitive negotiator at the helm, whereas many turnarounds require a more forceful authority.

# **CHAPTER 6**

## **Problem solving and Decision making**

**DR. T. J. JAYASHOLAN**

**Department of Management**

**Ponnaiyah Ramajayam Institute of science and Technology(PRIST)**

Effective problem solving is a key management skill and a major factor in determining individual and organizational success. People with good problem solving skills adapt more quickly in times of rapid change and are generally high achievers, whether it is by putting things right when they go wrong, making the best use of resources, or creating and exploiting opportunities. Whatever our personal and professional ambitions, we can improve our chances of achieving what we want and exploiting opportunities. Whatever our personal and professional ambitions, we can improve our chances of achieving what we want by developing your problem solving skills. Each of us has an innate ability to solve problems. To develop this ability we need a clear understanding of the skills and techniques involved and practice in applying them in different situations.

In the broadest sense, problem solving consists of devising a course of action which will enable us to achieve a particular goal or objective. It plays a fundamental role in our day-to-day lives, both through our own actions and those of others which affect us. Solving problems effectively requires an understanding of the problem solving process and the ability to use appropriate skills and techniques at the right time. To be a successful problem solver we must go through these stages:

- Recognizing and defining the problem
- Finding possible solutions
- Choosing the best solution
- Implementing the solution.

In this lesson the following objectives have been defined:

# **CHAPTER 7**

## **Creating Women Business Leaders**

**Dr. K. G. SELVAN**

**Department of Management**

**Ponnaiyah Ramajayam Institute of science and Technology(PRIST)**

### **Differentiating Styles of Women Executives**

Organizations that aim to deliver the highest standards of leadership require a diversity of thought and talent capability. It is increasingly being recognized that women do bring substantive diversity to company boards in terms of their composition, skill sets and experiences. Their intuitiveness, negotiation skills and the collaborative and inclusive styles of leadership that they inherently display would be seen as striking a fine balance with the more process-driven leadership culture, which is the hallmark of their male business peers and counterparts.

While much research has been conducted on gender stereotypes, the “Forum for Women in Leadership” (WILL Forum) conducted a survey on "Creating Women Business Leaders: Differentiating Styles of Women Executives" --to bring to light the personality and motivational factors that serve at the core of underlying gender differences in leadership. How do women executives define their leadership context? Are specific styles of leadership truly unique to women leaders?

This study, we aim to address the foregoing questions, which revolve around how leadership styles of women would contribute to enhanced business performance through collaborative leadership, public-spiritedness, flexible mindsets and high standards of work ethics.

Specifically, research evidence reveals that

1. Women leaders are self-critical of their own strengths and weaknesses and tend to rebound gracefully from setbacks.



## **CHAPTER 8**

### **Change Management**

**DR. S. VENKATESH**  
**Department of Management**  
**Ponnaiyah Ramajayam Institute of science and Technology(PRIST)**

The change means the alteration of status quo or making things different. It may refer to any alteration which occurs in the overall work environment of an organization. When an organizational system is disturbed by some internal or external force, the change may occur. The change is modification of the structure or process of a system, that may be good or even bad. It disturbs the existing equilibrium or status quo in an organization. The change in any part of the organization may affect the whole of the organization, or various other parts of organization in varying degrees of speed and significance. It may affect people, structure, technology, and other elements of an organization. It may be reactive or proactive in nature. When change takes place due to external forces, it is called reactive change. However, proactive change is initiated by the management on its own to enhance the organizational effectiveness. The change is one of the most critical aspects of effective management. It is the coping process of moving from the present state to a desired state that individuals, groups and organizations undertake in response to various internal and external factors that alter current realities.

Survival of even the most successful organizations cannot be taken for granted. In some sectors of the economy, organizations must have the capability to adapt quickly in order to survive. When organizations fail to change, the cost of failure may be quite high. All organizations exist in a changing environment and are themselves constantly changing. Increasingly, the organizations that emphasize bureaucratic or mechanistic systems are ineffective. The organizations with rigid hierarchies, high degree of functional specialization, narrow and limited job descriptions, inflexible rules and procedures, and impersonal management can't respond adequately to the demands for change. The organizations need designs that are flexible and adaptive. They also need systems that require both, and allow greater commitment and use of talent on the part of employees and managers. The organizations that do not bring about timely change in appropriate ways are unlikely to survive. One reason that the rate of change is accelerating is that knowledge and technology feed on themselves, constantly making innovations at exponential rates.

Organizational change is the process by which organizations move from their present state to some desired future state to increase their effectiveness. The goal of planned organizational change is to find new or improved ways of using resources and capabilities in order to increase an organization's ability to create value and improve returns to its stakeholders. An organization in decline may need to restructure its resources to improve its fit with the environment. IBM and General Motors, for example, experienced falling demand for their products in the 1990s and have been searching for new ways to use their resources to improve their performance and attract customers back. On the other hand, even a thriving organization may need to change the way it uses its resources so that it can develop new products or find new markets for its existing products. Wal-Mart, Google, Reliance, Tata group, Godrej like companies have been moving aggressively to expand their scale of operations and open new avenues to take advantage of the popularity of their products. In the last decade, over half of all Fortune 500 companies have undergone major organizational changes to allow them to increase their ability to create value.

Change may be regarded as one of the few constants of recorded history. Often society's "winners", both historical and contemporary, can be characterized by the common ability to effectively manage and exploit change situations. Individuals, societies, nations and enterprises who have at some time been at the forefront of commercial and/ or technological expansion have achieved domination, or at least 'competitive' advantage, by being innovative in thought and/or action. They have been both enterprising and entrepreneurial. It is said that management and change are synonymous; it is impossible to undertake

# **CHAPTER 9**

## **Organization Development Intervention**

**DR. P. BALASUBRAMANIAN**

**Department of Management**

**Ponnaiyah Ramajayam Institute of science and Technology(PRIST)**

### **Introduction**

An intervention is a deliberate process by which change is introduced into peoples' thoughts, feelings and behaviors. The overall objective of any intervention is to confront individuals, teams or units of people in a non-threatening way and allow them to see their self-destructive behavior and how it affects themselves and colleagues. It might involve several people who have prepared themselves to talk to the target group that has been engaging in some sort of self-destructive behavior. In a clear and respectful way, they inform the persons of factual information regarding their behavior and how it may have affected them. The immediate objective of an intervention is for the target to listen and to accept help. Organization Development (OD) intervention would be a combination of the ways a manager can influence the productivity of his/her team by understanding how managerial style impacts organizational climate and more importantly how to create an environment of high performance.

Most OD interventions are plans or programs comprised of specific activities designed to effect change in some facet of an organization. Numerous interventions have been developed over the years to address different problems or create various results. However, they all are geared toward the goal of improving the entire organization through change. In general, organizations that wish to achieve a high degree of organizational change will employ a full range of interventions, including those designed to transform individual and group behavior and attitudes. Entities attempting smaller changes will stop short of those goals, applying interventions targeted primarily toward operating policies, management structures, worker skills, and personnel policies.

## **CHAPTER 10**

### **Resistance to Change**

**MR. K. SASIKUMAR**

**Department of Management**

**Ponnaiyah Ramajayam Institute of science and Technology(PRIST)**

The goal of planned organizational change is to find new or improved ways of using resources and capabilities in order to increase an organization's ability to create value and improve returns to its stakeholders. An organization in decline may need to restructure its resources to improve its fit with the environment. At the same time even a thriving organization may need to change the way it uses its resources so that it can develop new products or find new markets for its existing products. In the last decade, over half of all Fortune 500 companies have undergone major organizational changes to allow them to increase their ability to create value. One of the most well-documented findings from studies have revealed that organizations and their members often resist change. In a sense, this is positive. It provides a degree of stability and predictability to behaviour. If there weren't some resistance, organizational behaviour would take on characteristics of chaotic randomness.

Resistance to change can also be a source of functional conflict. For example, resistance to a reorganization plan or a change in a product line can stimulate a healthy debate over the merits of the idea and result in a better decision. But there is a definite downside

to resistance to change. It hinders adaptation and progress. Resistance to change doesn't necessarily surface in standardized ways. Resistance can be overt, implicit, immediate or deferred. It is easiest for management to deal with resistance when it is overt and immediate: For instance a change is proposed and employees quickly respond by voicing complaints, engaging in a work slowdown, threatening to go on strike, or the like. The greater challenge is managing resistance that is implicit or deferred.



# INTELLECTUAL PROPERTY RIGHTS

Edited by  
**DR.K.G.SELVAN**



978-93-6255-151-1

**INTELLECTUAL PROPERTY RIGHTS**

**Copyright © 2018 by Dr. K. G. SELVAN**

All rights reserved. No part of this book may be reproduced or transmitted in any form or by any means without written permission from the author.

ISBN: 978-93-6255-151-1

Publisher: Ponnaiyah Ramajayam Institute of science and Technology (PRIST)

## TABLE OF CONTENTS

CHAPTER 1 Introduction to IPR .....	1
MR. K. SASIKUMAR	
CHAPTER 2 Introduction to Copy Rights.....	18
DR. P. BALASUBRAMANIAN	
CHAPTER 3 Patents .....	24
DR. K. RAJALAKSHMI	
CHAPTER 4 Fundamentals of Trade Mark .....	32
DR. R. PREMA	
CHAPTER 5 Trade Secrets .....	44
DR. S. VENKATESH	
CHAPTER 6 Managing IP Rights.....	59
DR. T. J. JAYASHOLAN	
CHAPTER 7: Protecting IP Rights.....	67
Dr. S. POUGAJENDY	
CHAPTER 8 Transferring IP Rights.....	75
DR. P. BALASUBRAMANIAN	
CHAPTER 9 Introduction to Cyber Law.....	86
MR. K. SASIKUMAR	
CHAPTER 10 Developing a Social Media Strategy.....	97
MRS. P. UMA ESWARI	

## **CHAPTER 1**

### **Introduction to IPR**

**MR. K. SASIKUMAR**

*Department of Management,*

**Ponnaiyah Ramajayam Institute of science and Technology(PRIST)**

Intellectual property (IP) pertains to any original creation of the human intellect such as artistic, literary, technical, or scientific creation. Intellectual property rights (IPR) refers to the legal rights given to the inventor or creator to protect his invention or creation for a certain period of time. These legal rights confer an exclusive right to the inventor/creator or his assignee to fully utilize his invention/creation for a given period of time. It is very well settled that IP play a vital role in the modern economy. It has also been conclusively established that the intellectual labor associated with the innovation should be given due importance so that public good emanates from it. There has been a quantum jump in research and development (R&D) costs with an associated jump in investments required for putting a new technology in the market place. The stakes of the developers of technology have become very high, and hence, the need to protect the knowledge from unlawful use has become expedient, at least for a period, that would ensure recovery of the R&D and other associated costs and adequate profits for continuous investments in R&D. IPR is a strong tool, to protect investments, time, money, effort invested by the inventor/creator of an IP, since it grants the inventor/creator an exclusive right for a certain period of time for use of his invention/creation. Thus IPR, in this way aids the economic development of a country by promoting healthy competition and encouraging industrial development and economic growth. Present review furnishes a brief overview of IPR with special emphasis on pharmaceuticals.

#### **BRIEF HISTORY**

The laws and administrative procedures relating to IPR have their roots in Europe. The trend of granting patents started in the fourteenth century. In comparison to other European countries, in some matters England was technologically advanced and used to attract artisans from elsewhere, on special terms. The first known copyrights appeared in Italy. Venice can be considered the cradle of IP system as most legal thinking in this area was done here; laws and systems were made here for the first time in the world, and other countries followed in due course. Patent act in India is more than 150 years old. The inaugural one is the 1856 Act, which is based on the British patent system and it has provided the patent term of 14 years followed by numerous acts and amendments.

#### **Types of Intellectual Properties and their Description**

Originally, only patent, trademarks, and industrial designs were protected as ‘Industrial Property’, but now the term ‘Intellectual Property’ has a much wider meaning. IPR enhances technology advancement in the following ways:

- (a) it provides a mechanism of handling infringement, piracy, and unauthorized use
- (b) it provides a pool of information to the general public since all forms of IP are published except in case of trade secrets.

IP protection can be sought for a variety of intellectual efforts including

## **CHAPTER 2**

### **Introduction to Copy Rights**

**DR. P. BALASUBRAMANIAN**  
*Department of Management,*  
**Ponnaiyah Ramajayam Institute of science and Technology(PRIST)**

In ancient days creative persons like artists, musicians and writers made, composed or wrote their works for fame and recognition rather than to earn a living, thus, the question of copyright never arose. The importance of copyright was recognized only after the invention of printing press which enabled the reproduction of books in large quantity practicable.

Copyright –Definition:

Copyright is a right of use given by the law to the creator of literary, dramatic, musical, artistic work , software etc for a limited period of time

In India all the law related to copyright is regulated by the copyright Act 1957. Its latest amendment was brought in 2012

A copyright is an exclusionary right. It conveys to its owner the right to prevent others from copying, selling, performing, displaying, or making derivative versions of a work of authorship.

#### Exclusive copyright rights

The entire bundle of rights that a copyright owner is exclusively entitled to exercise under the copyright laws. These rights consist of:

- the right to reproduce (copy) the work
- the right to prepare derivative works
- the right to distribute copies of the work
- the right to perform the work, and
- the right to display the work.

**COPYRIGHT ACT, 1957:** Copyright Act refers to laws that regulate the use of the work of a creator, such as an artist or author.

This includes copying, distributing, altering and displaying creative, literary and other types of work. Unless otherwise stated in a contract, the author or creator of a work retains the copyright.

Copyright does not ordinarily protect titles by themselves or names, short word combinations, slogans, short phrases, methods, plots or factual information.



## CHAPTER 3

### Patents

**DR. K. RAJALAKSHMI**

*Department of Management,*

**Ponnaiyah Ramajayam Institute of science and Technology(PRIST)**

#### **PATENTS**

A patent is a government granted right for a fixed time period to exclude others from making, selling, using, and importing an invention, product, process or design, or improvements on such items. These exclusive, monopoly rights are powerful, and in return the inventor is required to describe the invention in writing. The end result is simply a written description, accompanied by diagrams and drawings, that explains the invention. The public benefits because anyone can read the details of the invention and improve upon it. Importantly, the patent not only allows the public to gain an understanding of the invention, but also defines its limits. Once the patent term expires (generally 20 years from the application filing date), the technology covered by the patent becomes a part of the public domain and is essentially free to use by the public.

#### Types of Patents

Generally, there are three main types of patents: utility patents, design patents and plant patents.

1) Utility Patent – When most people think of patents, they are referring mainly to utility patents. A utility patent is a patent that covers inventions, whether it's an innovative software

process, a new product that is distinct from prior art, or an improvement to a car engine. A utility patent can be granted for any new, useful, and non-obvious process or product.

1) Design Patent – A design patent covers a new and original ornamental design of a product. In other words, a design patent protects the look of a product. Examples of products protected by design patents include jewelry and watches, electronic devices, computer icons, and beverage containers. A design patent consists of numerous drawings that show a product from various angles and contains very little written description, if any.

2) Plant Patents - Plant patents were first created by the Patent Act of 1930, which had been proposed by Luther Burbank to protect new species of asexually reproduced plants, mostly flowers. These are different than the utility patents granted to bioengineered plants used in agriculture. The United States was the first



# INTELLECTUAL PROPERTY RIGHTS

Edited by  
**DR.K.G.SELVAN**



978-93-6255-151-1

**CHAPTER 4**  
**Fundamentals of Trade Marks**

**DR. R. PREMA**  
*Department of Management,*  
Ponnaiyah Ramajayam Institute of science and Technology(PRIST)

**DEFINITION OF TRADEMARK:**

A trade mark is a word, phrase, symbol or design, or combination of words, phrases, symbols or designs used in the course of trade which identifies and distinguishes the source of the goods or services of one enterprise from those of others.

As stated above, the definition of "trade mark" under Section 2(1) is "A mark capable of being represented graphically and which is capable of distinguishing the goods or services of one person from others and may include shape of goods, their packaging and combination of colours and covers both goods and services".

"Mark" includes a device, brand, heading, label, ticket, name, signature, word, letter, numeral, shape of goods, packaging or combination of colours or any combination thereof". [Section 2(1)].

**PURPOSE AND FUNCTION OF TRADEMARKS**

A trade mark (popularly known as brand name in layman's language) is a visual symbol which may be a word to indicate the source of the goods, a signature, name, device, label, numerals, or combination of colours used, or services, or other articles of commerce to distinguish it from other similar goods or services originating from another. It is a distinctive sign which identifies certain goods or services as those produced or provided by a specific person or enterprise. Its origin dates back to ancient times, when craftsmen reproduced their signatures, or "marks" on their artistic or utilitarian products. Over the years these marks evolved into today's system of trade mark registration and protection. The system helps

consumers identify and purchase a product or service because its nature and quality, indicated by its unique trade mark, meets their needs.

A trade mark provides protection to the owner of the mark by ensuring the exclusive right to use it or to authorize another to use the same in return for payment. The period of protection varies, but a trade mark can be renewed indefinitely beyond the time limit on payment of additional fees. Trade mark protection is enforced by the courts, which in most systems have the authority to block trade mark infringement.

## **CHAPTER 5** **Trade Secrets**

**DR. S. VENKATESH**  
*Department of Management,*  
**Ponnaiyah Ramajayam Institute of science and Technology(PRIST)**

### TRADE SECRET LITIGATION:

- If a trade secret is disclosed in violation of a written confidentiality agreement, and the parties cannot resolve the dispute themselves, an action for breach of contract may be brought, similar to any other breach of contract action.
- The plaintiff may add other causes of action as well, for example, for misappropriation in violation of a state trade secret law. If no written agreement exists, the plaintiff must rely upon case law or state statutes protecting trade secrets, or both.
- To protect itself against a lawsuit by another alleging trade secret violation, companies should require new employees who will have access to confidential information to acknowledge in writing that accepting employment with the new company does not violate any other agreement or violate any other obligation of confidentiality to which the employee may be subject.
- If grounds for federal jurisdiction exist (the parties have diverse citizenship and the claim exceeds \$75000), the action may be brought in federal court.
- The UTSA [Uniform Trade Secrets Act] provides that an action for misappropriation must be brought within three years after misappropriation is discovered or reasonably should have been discovered.
- In federal court, the action will be governed by the Federal Rules of Civil Procedure relating to federal civil actions generally.

Most states have rules relating to civil procedure that are modeled substantially after the Federal Rules of Civil Procedure and likewise govern the litigation.

- If the defendant has a cause of action to assert against the plaintiff relating to the trade secret, it must be asserted by way of a counterclaim in the litigation so that all disputes between the parties relating to the information can be resolved at the same time.
- After the complaint, answer, and counterclaim have been filed, various motions may be made. Discovery will commence. The plaintiff and defendant will take depositions to obtain testimony from those who may have information about the case.
- Ultimately, if the matter cannot be resolved by private agreement, it will proceed to trial. The

## **CHAPTER 6** **Managing IP Rights**

**DR. T. J. JAYASHOLAN**  
*Department of Management,*  
**Ponnaiyah Ramajayam Institute of science and Technology(PRIST)**

### **Managing IP Rights**

In an increasingly knowledge-driven economy, Intellectual Property (IP) is an important key consideration in day-to-day business decisions. New products, brands and creative designs appear almost daily on the market and are the result of continuous human innovation and creativity. Generally, the small and medium companies in India either do not understand the value of their intellectual property assets or are not aware of the intellectual property system or the protection it can provide for their inventions, brands, and designs. As the Intellectual Property forms an important part of companies' assets, its adequate protection is crucial in deterring potential infringement and in turning ideas into business assets with a real market value. In fact, the Intellectual Property system enables companies to profit from their innovative capacity and creativity and enhance their competitiveness. Companies that dedicate time and resources for protecting their intellectual property can increase their competitiveness in a number of areas, as it prevents competitors from copying or closely imitating a company's products or services; avoids wasteful investment in research and development (R&D) and marketing; creating a corporate identity through a trademark and branding strategy; negotiating licensing, franchising or other Intellectual Property based contractual agreements; increasing the market value of the company; acquiring venture capital and enhancing access to finance; obtaining access to new markets and most important a careful search for conflicting existing Intellectual Property rights, and the examination of application by offices can help an enterprise to avoid conflicts and unnecessary litigation.

**Strategies for Effective IPR Management:** The effective management of intellectual property assets requires implementation of a comprehensive asset management plan. In this process, one of the most important step is to review the existing intellectual property assets, so as to identify and locate the company's key intellectual property assets such as patents, patentable subject matter, copyrights, trademarks, designs, trade secrets, domain names, mask

works, inventions, works of authorship, hardware and devices, depending upon the nature of business. Once the intellectual property assets are identified, it becomes important to determine nature and scope of the company's rights in intellectual property assets, which may range from outright ownership to a license- including contingent rights in intellectual

**CHAPTER 7**  
**Protecting IP rights**

**Dr. S. POUGAJENDY**  
*Department of Management,*  
**Ponnaiyah Ramajayam Institute of science and Technology(PRIST)**

Protecting IP Rights

Intellectual Property rights are key elements needed to maintain a competitive edge in the market in today's dynamic and competitive business environment. Intellectual property is a business asset, an integral part of the business process. Effective acquisition, management and protection of intellectual property can mean the difference between success and failure in businesses today. It is important that companies take appropriate steps to protect this valuable asset so as to get the possible commercial results from its ownership. The various statutes that have been enacted provide an adequate mechanism of protection to intellectual property rights. In the case of patents, a patent can provide an inventor/corporates with a 20-year government approved monopoly and once his 20 years of protection is up, it can be freely exploited for the good of society. However, some ideas cannot be patented and indeed, some innovators do not want to patent their ideas as for instance trade secret or confidential information.[Today more than ever, intellectual property also includes confidential business information, trade secrets, know-how and key business relationships]. If a trade secret is really kept a secret, the monopoly on an idea or product may never end. But once the genie's out of the bottle, like a champagne cork, you won't get it back in, it is lost forever and the companies are unlikely to extract sufficient damages from whoever breaches confidentiality. Trade secrets are free—just prevent the secret being disclosed. Though it is difficult indeed, but not impossible. Famous successful examples include the recipe for Coca-

## **CHAPTER 8**

### **Transferring IP Rights**

**DR. P. BALASUBRAMANIAN**  
*Department of Management,*  
**Ponnaiyah Ramajayam Institute of science and Technology(PRIST)**

#### Transferring IP Rights

When preparing to sell, many business owners think that their business doesn't have or own any intellectual property unless they have gone through the process of registering a copyright or trademark or procuring a patent. However, items such as domain names, trade secrets, and the special know-how of a business constitute intellectual property which have value and for which the business and/or business owners have rights. Additionally, items such as third-party licenses (Microsoft Office, for example), IT maintenance and support contracts, and web-hosting and development contracts also constitute valuable intellectual property. Proper consideration and handling of these items matter greatly in the sale of a business, as failure to consider or handle them properly can cause problems for the seller at the front and back end of a sale transaction.

Intellectual Property Licensing is a right by which the proprietor of the Intellectual Property Rights permits the licensee the enjoyment of commercial monopoly rights granted to him by the sovereign authority (Government) through Intellectual property legislations.

Licensing is a relationship where both parties to license agree to co-operate each other which benefit them. The proprietor (licensor) of the Intellectual property by a license agrees to share the monopoly right granted to him and Licensee agrees for negotiated compensation for such sharing of the monopoly right.

Intellectual Property License essentially is a contract by which licensor and licensee reduced the term of the license which can be enforceable as per the legal frame work under current municipal legislations where the contract has been executed.

#### Assignment Contract

The transfer of ownership in intellectual property is usually effected by a formal assignment. The whole, or part, of an intellectual property right can be assigned. An assignment of intellectual property is a document effecting the transfer of the ownership of intellectual property from one person to another. Assigning the ownership of intellectual property, should always be in writing by means of a formal agreement. Many IP rights cannot be properly assigned without a written document.

Assignment agreements are of considerable importance in IPR since they allow the intellectual property owners to transfer their intellectual property for commercial

## **CHAPTER 9**

### **Introduction to Cyber Law**

**MR. K. SASIKUMAR**  
*Department of Management,*  
**Ponnaiyah Ramajayam Institute of science and Technology(PRIST)**

Cyber Law:

Cyber law is the area of law that deals with the Internet's relationship to technological and electronic elements, including computers, software, hardware and information systems (IS).

Cyber law is also known as Cyber Law or Internet Law.

Cyber laws prevent or reduce large scale damage from cybercriminal activities by protecting information access, privacy, communications, intellectual property (IP) and freedom of speech related to the use of the Internet, websites, email, computers, cell phones, software and hardware, such as data storage devices.

The increase in Internet traffic has led to a higher proportion of legal issues worldwide. Because cyber laws vary by jurisdiction and country, enforcement is challenging, and restitution ranges from fines to imprisonment.

The Information Technology Act, 2000 (also known as ITA-2000, or the IT Act) is an Act of the Indian Parliament (No 21 of 2000) notified on 17 October 2000. It is the primary law in India dealing with cybercrime and electronic commerce. It is based on the United Nations Model Law on Electronic Commerce 1996 (UNCITRAL Model) recommended by the General Assembly of United Nations by a resolution dated 30 January 1997.

Cyber Crime:

Intellectual property (IP) theft is defined as theft of material that is copyrighted, the theft of trade secrets, and trademark violations. A copyright is the legal right of an author, publisher, composer, or other person who creates a work to exclusively print, publish, distribute, or perform the work in public. The United States leads the world in the creation and selling of IP products to buyers nationwide and internationally. Examples of copyrighted material commonly stolen online are computer software, recorded music, movies, and electronic games.

Theft of trade secrets means the theft of ideas, plans, methods, technologies, or any sensitive information from all types of industries including manufacturers, financial service institutions, and the computer industry. Trade secrets are plans for a higher speed computer, designs for a highly fuel-efficient car, a company's manufacturing procedures, or the recipe

for a popular salad dressing, cookie mix, or barbeque sauce. These secrets are owned by the company and give it a competitive edge. Theft of trade secrets damages the competitive edge and therefore the economic base of a business.



## **CHAPTER 10**

### **Developing a Social Media Strategy**

**MRS. P. UMA ESWARI**  
*Department of Management,*  
**Ponnaiyah Ramajayam Institute of science and Technology(PRIST)**

What is social media marketing?

Social media marketing means using social media platforms like Instagram, X (formerly known as Twitter) and Facebook to promote your brand and sell your product or service.

If your business comes out with a new item and you plan to promote the launch on social media, that's social media marketing. If you interact with your customers via comments, that's social media marketing. And if you create engaging content that showcases your brand's values and story, that's social media marketing too.

This form of marketing requires you to use social media management skills and tools. Just as you prepare other aspects of your marketing strategy, you need to have a plan for your social media marketing.

What is a social media marketing strategy?

A social media marketing strategy is a comprehensive plan that integrates your social media efforts with your team's goals and the broader business objectives. This alignment ensures that your activities are not only optimized for performance but also deliver measurable results that contribute to your overall marketing success.

A well-defined social media marketing strategy also sets clear boundaries around your team's time and expertise. Social media is a unique channel, and while nearly everyone uses it, this widespread usage often leads people to overestimate their expertise.

Every social media manager has faced requests to share content that isn't formatted correctly or doesn't align with the overarching campaign. Having a robust social media marketing strategy empowers you to confidently say "no" when necessary, ensuring that your efforts remain focused and effective.

What are the benefits of a social media strategy?

This question can feel like a bit of a no-brainer to marketers that live and breathe social. That said, being able to clearly articulate the advantages of a cohesive social media strategy is crucial for securing buy-in from other stakeholders. Here's how a well-defined social media strategy benefits your brand and business:

It increases brand awareness and engagement

According to The Sprout Social Index™ 2023, more than half (53%) of consumers say their social media usage has increased over the last two years. Amid a fractured cultural landscape, social media has emerged to fill a seemingly endless need for content.

When brands commit to a cohesive social media marketing strategy, they develop the consistency needed to form a brand identity that cuts through the noise to resonate with a target audience. Case in point: Figo Pet Insurance.



# **BUSINESS REGULATORY FRAME WORK**



EDITED BY

**DR.T.J.JAYASHOLAN**



978-93-6255-631-8

BUSINESS REGULATORY FRAME WORK  
Copyright © 2018 by Dr. T. J. JAYASHOLAN

All rights reserved. No part of this book may be reproduced or transmitted in any form or by any means without written permission from the author.

ISBN: 978-93-6255-631-8

Publisher: Ponnaiyah Ramajayam Institute of science and Technology (PRIST)

## TABLE OF CONTENTS

CHAPTER 1 Introduction to Business Law.....	1
DR. P. BALASUBRAMANIAN	
CHAPTER 2 Quasi Contracts.....	16
DR. S. VENKATESH	
CHAPTER 3 Special Contracts.....	23
DR. K. RAJALAKSHMI	
CHAPTER 4 Contract of Agency.....	34
DR. R. PREMA	
CHAPTER 5 The Goods and Sales Act 1930.....	43
MR. K. SASIKUMAR	
CHAPTER 6 Performance of the Sale of Contract.....	57
MRS. P. UMA ESWARI	
CHAPTER 7: The Consumer Protection Act, 1986.....	64
Dr. S. POUGAJENDY	
CHAPTER 8 Consumer Protection Council.....	76
DR. P. BALASUBRAMANIAN	
CHAPTER 9 The Information Technology.....	87
MR. K. SASIKUMAR	
CHAPTER 10 Electronic Governance.....	98
DR. R. PREMA	

**CHAPTER 1**  
**Introduction to Business Law**

**DR. P. BALASUBRAMANIAN**  
*Department of Management,*  
**Ponnaiyah Ramajayam Institute of science and Technology(PRIST)**

Business Law is a wide term and embraces all legal principles concerning business transactions. It is also known as the 'Commercial Law', 'Law Merchant' or 'Mercantile Law'.

Business Law consists of those legal rules, which govern and regulate the business activities, transactions and trade. It also encompasses the law relating to regulation of business associations and other incidental matters.

**Definition**

According to S R Davar, business law "means that branch of law which is applicable to or concerned with trade and commerce in connection with various mercantile or business transactions".

**Scope of Business Law**

The following legislation enacted by Indian Legislature from time to time is covered in the Indian Business Laws:

The Indian Contract Act, 1872.

The Negotiable Instruments Act, 1881. The Sale of Goods Act, 1930.

The Indian Partnership Act, 1932. The Insurance Act, 1972.

The Arbitration & Conciliation Act, 1996. The Law of Insolvency.  
Law Relating to Carriage of Goods

**Sources of Business Law**

The main sources of Indian Business Law are as follows:

**The English Mercantile Law** [Common Laws, Equity, Roman Laws and Case Laws],

**Statutes of the Indian Legislature** [Supreme and Subordinate Legislation],

**Judicial Decisions & Precedents** [Declaratory, Persuasive, Absolutely Authoritative & Conditionally Authoritative Precedents],

Customs and Usage.

**THE INDIAN CONTRACT ACT, 1872**

In India, the law relating to contracts is contained in the INDIAN CONTRACT ACT, 1872. The Act

came into force on the 1<sup>st</sup> day of September 1872, and it applies to the whole of India except the State of Jammu and Kashmir. The act does not deal with all the branches of law of contracts. The contracts relating to Partnership, Sale of Goods Act and Negotiable Instruments Act are outside the scope of the Indian Contract Act. The Indian Contract Act deals with:

The general principles applicable to all contracts;

The conditions, which are essential for making a valid contract; The principles applicable to quasi contracts;

The principles, which are applicable to a few special contracts, namely,

*The contracts of indemnity, The contracts of guarantee,*

*The contracts of bailment and agency, The contracts of agency.*

The law of contracts deals with agreements, which can be enforced through law courts. Law of contracts is the most important branch of mercantile law. It affects every person in one way or the other, as all of us

## CHAPTER 2 Quasi Contracts

**DR. S. VENKATESH**  
*Department of Management,*  
**Ponnaiyah Ramajayam Institute of science and Technology(PRIST)**

Under the Law of Contracts, the contractual obligations are voluntarily undertaken by the contracting parties. However, under certain circumstances, a person may receive a benefit to which the law regards another person as better entitled or for which the law considers he should pay to the other person, even though there is no contract between the parties. Such relationships are called quasi-contracts, because, although there is no contract or agreement between the parties, they are put in the same position as if there were a contract between them.

### Definition

Quasi contract is defined as “an obligation to pay a sum of money, whether liquidated or unliquidated, which arises independently of any contract, on the ground that in the circumstances of the case, it is considered by the law to be just debt”.

It is a debt or obligation constituted by the act of the law apart from any consent or intention of the parties or any privity of contract. These relationships are termed as quasi-contracts or constructive contracts under the English Law and “certain relations resembling those created by contracts” under the Indian Law.

A quasi-contract rests on the ground of equity that a person shall not be allowed to enrich himself unjustly at the expense of another. That is why the law of quasi-contracts is known as the law of restitution. Strictly speaking, a quasi-contract is not a contract at all. A contract is intentionally entered into. A quasi-contract, on the other hand, is created by law.

### **BASIS OF QUASI CONTRACTS**

The quasi contracts are based on the maxim of ‘*nemo debet locuplatari ex aliena justua*’, i.e., no man must grow rich out of another person’s costs. In other words, these are based on the equitable principle that a person shall not be allowed to enrich himself at the expense of another. Lord Mansfield explained the quasi-contracts on the principle that ‘Law as well as justice should try to prevent unjust enrichment’. The term ‘unjust enrichment’ means the enrichment of one person at the cost of another. The principle of ‘unjust enrichment’ requires, that

the defendant (against whom the case is filed) has been enriched by the receipt of a benefit. the enrichment is at the expense of the plaintiff (i.e., who files the case).  
the retention of the enrichment is unjust.

### **FEATURES OF QUASI-CONTRACTS**

The salient features of a quasi-contract are as under:

It is imposed by law and does not arise from any agreement.

The duty of a party and not the promise of any party is the basis of such contract.

The right under it is always a right to money and generally, though not always, to a liquidated sum of money.

The right under it is available against specific person(s) and not against the world. A suit for its breach may be filed in the same way as in case of a complete contract.

## CHAPTER 3 Special Contracts

**DR. K. RAJALAKSHMI**  
*Department of Management,*  
**Ponnaiyah Ramajayam Institute of science and Technology(PRIST)**

The Contract of Indemnity and Guarantee are specific types of Contract. Specific provisions have been made in the Contract Act with regard to these types of contracts. The special legal provisions relating to these contracts are contained in Sections 124 to 147 of the Indian Contract Act, 1872.

### CONTRACT OF INDEMNITY

The term 'indemnity' means security against hurt, loss or damage. A contract of indemnity refers to promise made by one person to make good any loss or damage another has incurred or may incur by acting at his request or for his benefit. A contract of Fire Insurance or Marine Insurance is a Contract of Indemnity.

#### Definition

According to Sec. 124 of the Contract Act, the contract of indemnity has been defined as:

*"A contract by which one party promises to save the other from loss caused to him by the conduct of the promisor himself or by the conduct of any other person".*

**Indemnifier:** The person who gives the indemnity, i.e., who promises to compensate for the loss, is known as indemnifier.

**Indemnity-holder:** The person, for whose protection the indemnity is given, i.e., who is protected against loss, is known as indemnity-holder or indemnified.

#### Example

A contract to indemnify B against the consequences of any proceeding which C may take against B in respect of a certain sum of Rs. 200. This is a contract of indemnity. A is the indemnifier (Promisor) and B is the indemnified (Promisee).

#### **Characteristics of a Contract of Indemnity**

The important features of an Indemnity Contract are as follows:

**Essentials of a valid contract:** It must have all the essential elements of a valid contract, such as agreement, free consent, competency of the parties, legality of object and consideration.

**Compensation of loss:** This is the most important element of a contract of indemnity. One party must promise to save the other party from any loss which he may suffer.

**Express or Implied:** The promise to indemnify a person against the loss suffered by him, may be express or implied. The express promise is one where a person promises in express terms to compensate the other from the loss. And the implied promise is one where the conduct of the



## CHAPTER 4 Contract of Agency

**DR. R. PREMA**  
*Department of Management,*  
**Ponnaiyah Ramajayam Institute of science and Technology(PRIST)**

### CONTRACT OF AGENCY

A person who is competent to make a contract may do so (i) either by himself or (ii) through another person. When he makes contracts through another person; he is said to be making a contract through an agent. The person who acts on behalf of another or who represents a person in dealing with third parties is called as an 'agent' and the person on whose behalf he acts or who is thus represented, is called as 'principal'. The contract which creates the relationship of principal and agent is known as 'agency'. The legal provisions relating to agency are contained in Chapter X (Sections 182 to 238) of the Indian Contract Act, 1872.

### AGENT

According to Section 182 of the Contract Act defines an 'agent' as "a person employed to do any act for another or to represent another in dealings with third parties".

### PRINCIPAL

The person for whom such act is done, or who is so represented, is called the principal.

### AGENCY

The relationship between an agent and the principal is called agency, which may be created by an express or implied agreement.

Example:

X appointed Y to purchase 100 bags of rice on his behalf. In this case, X is the principal, and Y, the agent. And the relationship between X and Y is known as agency.

### GENERAL RULE OF AGENCY

There are two important rule of agency:

**Whatever a person can do personally, he can do through an agent:** Whatever a person competent to contract may do by himself, he may do through an agent except for acts involving personal skill and qualification such as painting, marriage, singing etc.

**He who does an act through another does it by himself:** This means that the acts of agent are, for all legal purposes, the acts of the principal (Sec. 226).

### ESSENTIALS OF A CONTRACT OF AGENCY

**Existence of agreement:** There must be an agreement by which a person is appointed as an agent by the other. The agreement may be express or implied.

**Competency of the Principal:** According to Section 183, "any person who is of the age of majority according to the law to which he is subject and who is of a sound mind, may employ



## CHAPTER 5 THE SALE OF GOODS ACT 1930

MR. K. SASIKUMAR  
*Department of Management,*  
Ponnaiyah Ramajayam Institute of science and Technology(PRIST)

### THE SALE OF GOODS ACT 1930

The law relating to the sale of goods or movables in India is contained in the Sale of Goods Act, 1930<sup>st</sup> which came into force on 1 July, 1930. Prior to the enactment of the Sale of Goods Act, 1930, the law of sale of goods was contained in Chapter VII of the Indian Contract Act 1872. The Act contains sixty-six sections and extends to the whole of India, except the State of Jammu and Kashmir.

#### Contract of sale

Under Section 4 (1) of the Sale of Goods Act, 1930, the contract of sale of goods is defined as follows:

*“A contract of sale of goods is a contract whereby the seller transfers or agrees to transfer the property in goods to the buyer for a price.”*

A contract of sale may provide for:

**Sale:** A contract of sale may be absolute or conditional. Where the right of ownership in the goods is transferred from the seller to the buyer, the contract is sale.

**Agreement to sell:** Where under a contract of sale the transfer of property in the goods is to take place at a future time or subject to some condition thereafter to be fulfilled, the contract is called an agreement to sell.

#### Essentials of a Valid Contract of Sale

**Contract:** All the essential elements of a contract must be present in a contract of sale.

**Two parties:** There must be two parties to constitute a contract of sale namely; a buyer and a seller. The same person cannot both be a seller and a buyer.

**Goods:** The subject matter of a contract of sale will always be goods. The goods may be either existing goods, future goods or contingent goods.

**Transfer of property:** In a contract of sale, the seller must transfer or agree to transfer property in the goods to the buyer.

**Price:** The consideration for a contract of sale must be money called the price.

### CONDITIONS AND WARRANTIES

#### Stipulation

‘Stipulation’ means a requirement or a specified item in an agreement”. In a contract of sale of goods, stipulation refers to representations made by the buyer and the seller reciprocally as a part of negotiation between them before they enter into a contract.

#### Meaning of Conditions and Warranties

## CHAPTER 6

### PERFORMANCE OF THE SALE OF CONTRACT

MRS. P. UMA ESWARI

*Department of Management,*

Ponnaiyah Ramajayam Institute of science and Technology(PRIST)

#### PERFORMANCE OF THE SALE OF CONTRACT

A contract of sale consists of two reciprocal

promises: The seller's duty to deliver the goods;

and

The buyer's duty to accept the goods and pay the price.

It may be noted that the delivery of goods and the payment of their price are the concurrent conditions, i.e., both these conditions should be performed simultaneously.

#### **Delivery of Goods**

Section 2 (2) of the Act defines, delivery to mean "voluntary transfer of possession from one person to another." Such voluntary transfer can, as Sec. 33 states, be made by doing anything which has the effect of putting the goods in the possession of the buyer or his authorized agent.

#### Modes of Delivery

Delivery of goods may be made in any of the following ways:

**Actual delivery:** Where the goods are physically handed over by the seller to the buyer, the delivery is said to be actual.

**Symbolic delivery:** Where the goods are bulky and incapable of actual delivery, there are other means of obtaining possession of goods are delivered by the seller to the buyer. **Constructive or Delivery by attornment:** Where the goods at the time of sale are in the possession of a third person, there is no delivery by seller to buyer unless and until such third person acknowledges to the buyer that he holds the goods on his behalf."

#### Rules Regarding Effective Delivery of Goods

***Delivery and payment are concurrent conditions [Sec. 32]:*** The seller shall be ready and willing to give possession of goods to the buyer in exchange for the price and the buyer shall be ready and willing to pay the price in exchange for possession of the goods.

***Delivery may be either actual, symbolic or constructive [Sec. 33]:*** The delivery of goods must have the effect of putting the goods in the possession of buyer or his authorized agent.

***Effect of part delivery [Sec. 34]:*** A delivery of part of the goods, in progress of the delivery of the whole, has the same effect, for the purpose of passing the property in such goods, as a delivery of the whole.

***Buyer should apply for delivery [Sec. 35]:*** Apart from any express contract the seller

**CHAPTER 7**  
The Consumer Protection Act, 1986

**Dr. S. POUGAJENDY**  
*Department of Management,*  
**Ponnaiyah Ramajayam Institute of science and Technology(PRIST)**

The Preamble to the Consumer Protection Act, 1986 reads as under:

“An Act to provide for the protection of the interests of consumers and for that purpose to make provision for the establishment of Consumer Councils and other authorities for the settlement of consumer’s disputes and for matters connected therewith.”

The rights given to the consumers under the Act are based on the basic rights as defined by the International Organization of Consumers (IOCU) i.e., the Rights to Safety, Information, Choice, Redressal, Hearing, Education and Healthy environment.

**Scope and Applicability**

The Consumer Protection Act, 1986 extends to the whole of India except the State of Jammu and Kashmir. It applies to all types of goods and services, public utilities and public sector undertakings. Complaints of all types whether relating to goods, services or unfair trade practices have been brought within the purview of the Act. The provisions of the Act are in addition to and not in derogation of provision of any law for the time being in force (Sec. 3).

The Act may be regarded as a highly progressive social welfare legislation which provides more effective protection to the consumers than any corresponding legislations.

**Definition of Terms Complainant [Sec. 2 (l) (b)]**

The person who can make a complaint before a Consumer Redressal Forum may be:

a consumer, or any voluntary consumer association registered under the Companies Act, 1956 or under any other law for the time being in force, or the Central or State Government, or one or more consumers, where there are numerous consumers having the same interest, or in case of death of a consumer, his legal heir or representative.

The persons falling within the ambit of Section 2 (l) (b) are considered complainants and have a *locus standi* to file a complaint under the Act. A public cause can be taken up by an association in the form of public interest litigation.

**CHAPTER 8**  
**Consumer Protection Councils**

**DR. P. BALASUBRAMANIAN**  
*Department of Management,*  
**Ponnaiyah Ramajayam Institute of science and Technology(PRIST)**

**Consumer Protection Councils**

The Consumer Protection Councils are established at Central Level, State Level and District Level. These councils work towards the promotion and protection of the rights of the consumers. They give publicity to the matters concerning consumer interests; take necessary steps for consumer education and protecting consumers from exploitation.

**Central Consumer Protection Councils**

Section 4 provides that:

The Central Government shall, by notification, establish a council to be known as the Central Consumer Protection Council (hereinafter referred to as the Central Council).

The Central Council shall consist of the following members, namely:

the Minister-in-charge of Consumer Affairs in the Central Government, who shall be its Chairman, and

such number of other official or non-official members representing such interests as may be prescribed.

**State Consumer Protection Councils**

Section 7 provides that:

The State Government shall, by notification, establish a council to be known as the State Consumer Protection Council (hereinafter referred to as the State Council).

The State Council shall consist of the following members, namely:

the Minister-in-charge of Consumer Affairs in the State Government, who shall be its Chairman, and

such number of other official or non-official members representing such interests as may be prescribed by the State Government.

such number of other official or non-official members, not exceeding 10, as may be nominated by the Central Government.

The State Council shall meet as and when necessary but not less than 2 meetings shall be held every year.

The procedure to be observed in regard to the transaction of its business at such meetings shall be prescribed by the State Government.

**District Consumer Protection Council**

Section 8-A provides that:

The State Government shall establish for every district, by notification, a council to

**CHAPTER 9**  
**THE INFORMATION TECHNOLOGY ACT, 2000**

**MR. K. SASIKUMAR**  
*Department of Management,*  
**Ponnaiyah Ramajayam Institute of science and Technology(PRIST)**

### Introduction

Now-a-days the information technology has played an important role in the business transactions all over the world. The people were used digital technology and new communication systems for communicating business transactions in the business. Now businessmen as well as individuals are increasingly using computers to create, transmit and store information in the electronic form instead of traditional paper documents, as it is cheaper, easier and speedier.

Information stored in electronic form has many advantages. Although people are aware of these advantages of electronic medium, they are reluctant to conduct business or conclude any transaction in the electronic form due to lack of appropriate legal framework. It is, therefore, proposed to provide for legal recognition of electronic records and digital signatures. To prevent the possible misuse arising out of transactions and other dealings concluded over the electronic medium, it is also proposed to create civil and criminal liabilities for contravention of the provisions of the proposed legislation.

The Information Technology Bill was passed by both Houses of Parliament and it received the assent of the President on 9 June, 2000 and became The Information Technology Act, 2000 (21 of 2000). The Act came into force on 17<sup>th</sup> October, 2000 vide G.S.R 788 (E) dated 17<sup>th</sup> October, 2000.

The Information Technology Act, 2000 is based on the Model Law on Electronic Commerce which was adopted by the United Nations Commission on International Trade and Law (UNCITRAL) in 1996. The Model Laws provide for equal legal treatment of users of electronic communication and paper based communication.

### Scope and Extent

The Information Technology Act, 2000 shall extend to the whole of India.

Unless otherwise provided in the Act, it applies also to any offence or contravention there under committed outside India by any person.

The Act shall not apply to the following:

a negotiable instrument as defined in Section 13 of the Negotiable Instruments Act, 1881; a Power-of-Attorney as defined in Section 1 A of the Power-of-Attorney Act, 1882; a Trust as defined in Section 3 of the Indian Trusts Act, 1882; a Will as defined in clause (h) of Section 2 of the Indian Succession Act, 1925 including any other testamentary disposition by whatever name called; any contract for the sale or conveyance of immovable property or any interest in such property; any such class

**CHAPTER 10**  
**Electronic Governance**

**DR. R. PREMA**  
*Department of Management,*  
**Ponnaiyah Ramajayam Institute of science and Technology(PRIST)**

**Electronic Governance**

The object of the Information Technology Act, 2000 is to provide legal recognition for transactions carried out by means of electronic data interchange and other means of electronic communication commonly referred to as 'electronic commerce'. The Act facilitates electronic governance to accord legal recognition to electronic record, digital signatures, and electronic form of dealing with government offices and its agencies. Following legal provisions relating to the electronic governance are provided in the Act:

- 1) **Legal recognition of electronic records [Section 4]:** Where any law provides that information or any other matter shall be in writing or in the typewritten or printed form, then, inspite of anything contained in such law, such requirement shall be deemed to have been satisfied if such information or matter is —

**(a)** rendered or made available in an electronic form; and

**(b)** accessible so as to be usable for a subsequent reference.

- 2) **Legal recognition of digital signature [Section 5]:** Where any law provides that information or any other matter shall be authenticated by affixing the signature or any document shall be signed or bear the signature of any person, then, inspite of anything contained in such law, such requirement shall be deemed to have been satisfied, if such information or matter is authenticated by means of digital signature affixed in such manner as may be prescribed by the Central Government.

3) Use of electronic records and digital signatures in government and its agencies  
**[Section 6]:** Where any law provides for the following requirements i.e., in any other law for the time being in force, such requirement shall be deemed to have been satisfied if such filing, issue, grant, receipt or payment, as the case may be, is effected by means of such electronic form as may be prescribed by the appropriate Government [Section 6(1)].

**Retention of electronic records [Section 7]:** Where any law provides that documents, records or information shall be retained for any specific period, then, that requirement shall be deemed to have been satisfied if such documents, records or information are retained in the electronic form, if—

the information contained therein remains accessible so as to be usable for a subsequent reference;

the electronic record is retained in the format in which it was originally generated, sent or received or in a format which can be demonstrated to represent accurately the information originally generated, sent or received;

the details which will facilitate the identification of the origin, destination, date and time of despatch or receipt of such electronic record are available in the electronic record:

**Publication of rules, regulation etc. in electronic Gazette [Section 8]:** where any rule, regulation, order, by-law, notification or any other matter is published in the Official Gazette or Electronic Gazette, the date of publication shall be deemed to be the date of the Gazette which was first published



# FOUNDATION OF DATASCIENCE

EDITED BY

S.GAYATHRI



978-93-6255-548-9

FOUNDATION OF DATASCIENCE

Copyright © 2018 by Mrs.S. GAYATHRI

All rights reserved. No part of this book may be reproduced or transmitted in any form or by any means without written permission from the author.

ISBN: 978-93-6255-548-9

Publisher: Ponnaiyah Ramajayam Institute of Science and Technology (PRIST)



## TABLE OF CONTENT

S.NO	TOPICS	PAGE NO
1	Introduction of Data science Ms.S.Gayathri	03
2	Describing Data Ms.S.Gayathri	40
3	Describing Relationship Mr. S.Ameresan	73
4	Python Libraries for data wrangling Mr.K Sangeetha	120
5	Data Mining Mrs.k.Sangeetha	140
6	Correlation Mrs.K.Jayanthi	150
7	Pivot Table Mrs.M.Jeeva	158
8	Line plots Mrs.s.Gayathri	165
9	Customization Mr.K.Jayanthi	178
10	Visulization with seaborn Mrs.M.Mohana Priya	187
11	REFERENCE	200

# CHAPTER 1

## INTRODUCTION TO DATASCIENCE

Mr.S.Gayathri

### Introduction to Data Science

**Definition:** Data Science is an interdisciplinary field that uses scientific methods, processes, algorithms, and systems to extract knowledge and insights from structured and unstructured data. It combines techniques from statistics, computer science, and domain-specific knowledge to analyze and interpret complex data.

### Key Components of Data Science:

#### 1. Data Collection:

- **Definition:** The process of gathering data from various sources, which can include databases, APIs, sensors, surveys, and web scraping.
- **Techniques:**
  - **Web Scraping:** Extracting data from websites using tools and libraries like BeautifulSoup or Scrapy.
  - **APIs:** Using application programming interfaces to retrieve data from online services (e.g., Twitter API, Google Maps API).
  - **Databases:** Querying relational databases (SQL) or non-relational databases (NoSQL) to collect data.

### 3. Tools and Technologies

#### 1. Programming Languages:

- **Python:** Widely used for data manipulation, analysis, and visualization. Libraries include Pandas, NumPy, Matplotlib, Seaborn, Scikit-learn, TensorFlow, and PyTorch.
- **R:** Used for statistical analysis and data visualization. Packages include ggplot2, dplyr, and tidyr.

#### 2. Data Storage and Management:

- **Databases:** SQL-based databases (MySQL, PostgreSQL) and NoSQL databases (MongoDB, Cassandra).
- **Data Warehouses:** Amazon Redshift, Google BigQuery, Snowflake.

### 4. Data Science Lifecycle

#### 1. Problem Definition:

- Define the business problem or question to be answered with data.

#### 2. Data Acquisition:

- Gather and integrate data from various sources.

#### 3. Data Preparation:

- Clean, preprocess, and transform data for analysis.

#### 4. Exploratory Analysis:

- Perform initial data exploration and visualization to understand data characteristics.

**CHAPTER 2**  
**DESCRIBING DATA**  
Mr.S.Gayathri

## **Describing a Database**

### **Definition:**

- A database is an organized collection of structured information or data, typically stored electronically in a computer system. Databases are designed to manage, retrieve, and manipulate data efficiently and securely.

### **Key Components:**

#### **1. Data:**

- **Tables:** Fundamental structures where data is stored in rows and columns. Each table represents a specific entity or concept.
- **Rows:** Individual records or entries in a table. Each row represents a single instance of the entity.
- **Columns:** Attributes or fields of the table. Each column holds a specific type of data for the records.

### **Schema:**

- **Definition:** The blueprint or design of the database. It defines the structure of the database, including tables, columns, relationships, and constraints.
- **Components:** Includes definitions of tables, columns, data types, indexes, and relationships.

### **□ Database Management System (DBMS):**

- **Definition:** Software that facilitates the creation, management, and manipulation of databases. It provides an interface for users to interact with the database.
- **Types:**
  - **Relational DBMS (RDBMS):** Manages data in tables with relationships between them. Examples include MySQL, PostgreSQL, Oracle, and Microsoft SQL Server.
  - **NoSQL DBMS:** Manages data in various formats such as key-value pairs, documents, or graphs. Examples include MongoDB, Cassandra, and Redis.

### **□ Types of Databases**

#### **1. Relational Databases:**

- **Definition:** Use tables to represent data and relationships between data. They rely on structured query languages (SQL) for database operations.
- **Examples:** MySQL, PostgreSQL, Oracle Database, Microsoft SQL Server.
-

**CHAPTER 3**  
**DESCRIBING RELATIONSHIP**  
Mr.S.Ameresan

## **Describing Relations in Databases**

In the context of relational databases, a relation represents a fundamental concept that refers to a table of data. Here's a detailed description of what a relation is and its key aspects:

### **1. Definition of Relation**

- **Relation:**
  - A relation in a database is essentially a table that consists of rows and columns. Each row in the table represents a unique record, and each column represents an attribute or property of the data.

### **2. Components of a Relation**

1. **Table:**
  - **Definition:** The structure where data is stored. A table is organized into rows and columns.
2. **Rows (Tuples):**
  - **Definition:** Each row in a table represents a single record or instance of the entity described by the table. Each row contains data for each attribute.
  - **Characteristics:**
    - **Uniqueness:** Each row should be unique based on the primary key.
    - **Order:** Rows have no inherent order; the order of rows is not significant in a relational database.

### **3. Columns (Attributes):**

- **Definition:** Each column represents a specific attribute or field of the entity described by the table. Each column has a defined data type (e.g., integer, text, date).
- **Characteristics:**
  - **Data Type:** Specifies the type of data that can be stored in the column.
  - **Domain:** Defines the permissible values for the column.

### **3. Example of a Relation**

Consider the following example of a relation in a relational database:

- Table:** Employees
- Rows:** Each row represents an employee record.
- Columns:** Employee ID, First Name, Last Name, Department, Hire Date
- Primary Key:** Employee ID (uniquely identifies each employee)

# CHAPTER 4

## PYTHON LIBRARIES FOR DATA WRANGLING

Ms.K.Snageetha

### Python Libraries for Data Wrangling

Data wrangling, also known as data cleaning or data preprocessing, involves transforming and mapping raw data into a more useful format for analysis. Python offers a rich ecosystem of libraries to assist with various aspects of data wrangling.

#### 1. Pandas

- **Description:** Pandas is one of the most widely used libraries for data manipulation and analysis. It provides data structures and functions needed to work with structured data seamlessly.
- **Key Features:**
  - **Data Frames:** Two-dimensional, size-mutable, and potentially heterogeneous tabular data structures with labeled axes (rows and columns).
  - **Series:** One-dimensional labeled array capable of holding any data type.

#### 2. NumPy

- **Description:** NumPy is fundamental for scientific computing with Python. It provides support for arrays and matrices, along with a collection of mathematical functions to operate on these arrays.
- **Key Features:**
  - **Arrays:** Efficient storage and manipulation of large arrays and matrices of numeric data.
  - **Mathematical Functions:** Functions for linear algebra, statistical operations, and more.

#### 3. Dask

- **Description:** Dask provides parallel computing with task scheduling and integrates with Pandas and NumPy to handle larger-than-memory computations.
- **Key Features:**
  - **Parallel Computing:** Distributed computing and parallel processing for large datasets.
  - **Compatibility:** Scales Pandas and NumPy operations.

#### 4. Pyjanitor

- **Description:** Pyjanitor extends the capabilities of Pandas with additional cleaning functions and methods to make data wrangling tasks more intuitive.
- **Key Features:**
  - **Chaining Operations:** Streamlined syntax for chaining multiple data wrangling operations.
  - **Additional Functions:** Methods for cleaning column names, filtering data, and more.

# CHAPTER 5

## DATA MINING

Ms.K.Sangeetha

### Data Mining

Data mining involves extracting useful information and patterns from large datasets using various techniques and algorithms. It's an essential process in data science and analytics, aimed at discovering previously unknown patterns or insights that can inform decision-making.

#### 1. Definition and Purpose

##### Definition:

- Data mining is the process of discovering patterns, correlations, trends, and useful information from large datasets using techniques from statistics, machine learning, and database systems.

##### Purpose:

- To uncover hidden patterns and relationships in data.
- To generate actionable insights that can drive business strategies and decisions.
- To enhance predictive capabilities and automate decision-making processes.

#### 2. Data Mining Process

##### 1. Problem Definition:

- **Objective:** Define the problem you want to solve or the question you need to answer.
- **Example:** Identifying customer segments for targeted marketing.

##### 2. Data Collection:

- **Sources:** Gather data from various sources like databases, data warehouses, web scraping, APIs, and more.
- **Example:** Collecting sales data, customer demographics, and transaction history.

#### 3. Tools and Libraries for Data Mining

##### 1. Python Libraries:

- **Scikit-Learn:** Provides simple and efficient tools for data mining and machine learning.
  - **Example:** `from sklearn.cluster import KMeans`
- **TensorFlow and Keras:** Libraries for building and training deep learning models.
  - **Example:** `import tensorflow as tf`
- **PyCaret:** An open-source library that automates machine learning workflows.
  - **Example:** `from pycaret.classification import *`
- **XGBoost and LightGBM:** Libraries for gradient boosting, useful for building predictive models.
  - **Example:** `import xgboost as xgb`

## CHAPTER 6

### CORRELATION

Mrs. k. Jayanthi

#### Correlation

**Correlation** is a statistical measure that describes the strength and direction of the relationship between two variables. Understanding correlation helps to identify how changes in one variable are associated with changes in another. Here's an in-depth look at correlation:

##### 1. Definition of Correlation

- **Correlation:** It quantifies the degree to which two variables change together. If one variable tends to increase as the other increases, they are positively correlated. Conversely, if one variable tends to decrease as the other increases, they are negatively correlated.

##### 2. Types of Correlation

###### 1. Positive Correlation:

- **Description:** When one variable increases, the other variable also increases.
- **Example:** The relationship between height and weight—generally, taller people weigh more.

###### 2. Negative Correlation:

- **Description:** When one variable increases, the other variable decreases.
- **Example:** The relationship between the amount of exercise and weight—more exercise often correlates with lower weight.

###### 3. No Correlation:

- **Description:** No discernible pattern or relationship between the variables.
- **Example:** The relationship between shoe size and intelligence.

##### 3. Correlation Coefficient

The **correlation coefficient** quantifies the strength and direction of the correlation between two variables. The most common correlation coefficients are:

###### 1. Pearson Correlation Coefficient ( $r$ ):

- **Description:** Measures the linear relationship between two continuous variables.
- **Range:** -1 to 1
  - **1:** Perfect positive linear relationship.
  - **-1:** Perfect negative linear relationship.
  - **0:** No linear relationship.

##### 4. Correlation Matrix

- **Description:** A table that displays the correlation coefficients between multiple variables. It helps to visualize the relationships between all pairs of variables.

## CHAPTER 7

### PIVOT TABLE

Mrs.M. Jeeva

#### Pivot Table

A pivot table is a data processing tool used in spreadsheets and data analysis to summarize, sort, reorganize, group, count, total, or average data stored in a table. Pivot tables are powerful for data exploration and reporting, allowing users to quickly analyze large datasets by aggregating and summarizing information in a user-friendly manner.

#### 1. Definition and Purpose

- **Definition:** A pivot table is a table of statistics that summarizes the data of a more extensive table. It allows users to dynamically rearrange and aggregate data to provide different perspectives and insights.
- **Purpose:**
  - **Data Summarization:** Aggregate data from a detailed table to provide summary statistics.
  - **Data Analysis:** Identify trends, patterns, and relationships in the data.
  - **Data Presentation:** Create concise and informative reports for decision-making.

#### 2. Components of a Pivot Table

1. **Rows:**
  - **Description:** Fields that define the rows of the pivot table. They help to categorize data into different groups.
  - **Example:** Sales data grouped by product category.
2. **Columns:**
  - **Description:** Fields that define the columns of the pivot table. They help to segment data into categories along the horizontal axis.
  - **Example:** Sales data segmented by months.
3. **Values:**
  - **Description:** The actual data to be summarized or aggregated in the pivot table. Common operations include sum, average, count, min, and max.
  - **Example:** Total sales amount, average sales, or number of transactions.
4. **Filters:**
  - **Description:** Fields that can be used to include or exclude specific data from the pivot table. They allow users to focus on particular segments or criteria.
  - **Example:** Filtering sales data to show only data for a specific region or time period.
5. **Slicers (Optional):**
  - **Description:** Interactive filters that allow users to visually filter data in the pivot table.
  - **Example:** A slicer to filter sales data by product category



## CHAPTER 8

### LINE PLOTS

Mrs.K. Jayanthi

#### Line Plots

A line plot is a type of chart used to display information about changes over time or continuous data. It is particularly effective for showing trends and patterns within a dataset. Here's a comprehensive overview of line plots:

#### 1. Definition and Purpose

##### Definition:

- A line plot is a graph that uses lines to connect individual data points. Each point represents a value, and the lines show the progression or trend between these points.

##### Purpose:

- To visualize data trends over time or across a continuous variable.
- To identify patterns, fluctuations, and relationships in the data.
- To compare multiple datasets or variables.

#### 2. Components of a Line Plot

##### 1. Data Points:

- **Description:** Individual values plotted on the graph.
- **Example:** Monthly sales figures for a year.

##### 2. Lines:

- **Description:** Connect data points to show trends over time or across a continuous variable.
- **Example:** A line connecting monthly sales figures to show sales trends.

##### 3. X-Axis:

- **Description:** The horizontal axis that typically represents time or the continuous variable.
- **Example:** Dates, time periods, or categories.

##### 4. Y-Axis:

- **Description:** The vertical axis that represents the values of the data points.
- **Example:** Sales amount, temperature, or any numeric value.

##### 5. Legend (if applicable):

- **Description:** Explains what each line or data series represents, especially if multiple lines are used.
- **Example:** Different lines representing different products or regions.

##### 6. Title and Labels:

- **Description:** The title describes the chart's purpose, and labels indicate the axes' meanings.
- **Example:** Title: "Monthly Sales Trends", X-Axis Label: "Month", Y-Axis Label: "Sales Amount".

## CHAPTER 9 CUSTOMIZATION

Mrs.K. Jayanthi

### Customization of Line Plots

Customizing line plots allows you to enhance their readability and effectiveness, making them more suited to your specific data and presentation needs. Customization can range from adjusting colors and styles to adding annotations and interactive features. Below, I'll cover various aspects of line plot customization, primarily focusing on Python's matplotlib library, but the principles are applicable in other tools like Excel and Google Sheets as well.

#### 1. Basic Customizations

In Python (Matplotlib):

##### 1. Change Line Color and Style:

```
import matplotlib.pyplot as plt

months = ['Jan', 'Feb', 'Mar', 'Apr', 'May']

sales = [200, 250, 300, 280, 320]

plt.plot(months, sales, color='green', linestyle='--', linewidth=2, marker='o', markersize=8)
plt.title('Monthly Sales Trends')

plt.xlabel('Month')

plt.ylabel('Sales Amount')

plt.grid(True) plt.show()
```

##### Modify Marker Style:

```
plt.plot(months, sales, color='blue', marker='s', markersize=10, markeredgcolor='black')
```

##### Adjust Line Width:

```
plt.plot(months, sales, linewidth=3)
```

##### Add a Legend:

```
plt.plot(months, sales, label='Sales') plt.legend()
```

## CHAPTER 10 VIRTULIZATION WITH SEABORN

Mrs.M. Mohana Priya

Sea born is a powerful Python library for statistical data visualization built on top of Matplotlib. It simplifies the process of creating complex visualizations and provides a high-level interface for drawing attractive and informative statistical graphics. Although Sea born doesn't directly handle virtualization in the traditional sense (like creating virtual machines or containers), it is excellent for visualizing data and can be integrated into various workflows for data analysis and visualization.

### 1. Installation

To use Sea born, you first need to install it. You can do this using pip:

```
pip install sea born
```

Here's a rundown of common plot types and their customizations with Sea born:

#### 1. Line Plot

Line plots are useful for visualizing trends over time or continuous data.

```
import sea born as sns

import matplotlib. pyplot as plt

data = sns.load_dataset('flights')

pivot_data = data

.pivot_table(index='month', columns='year', values='passengers')

sns.lineplot(data=pivot_data)

plt.title('Number of Passengers Over Time')

plt.xlabel('Month')

plt.ylabel('Number of Passengers')

plt.show()
```

# C PROGRAMMING

Edited By  
**S. JANCY SICKORY DIASY**

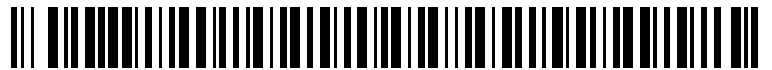

**978-93-6255-040-8**

## C PROGRAMMING

Copyright © 2018 By Ms.S.Jancy Sickory Diasy

All rights reserved. No part of this book may be reproduced or transmitted in any form or by any means without written permission from the author.

ISBN: 978-93-6255-040-8

Publisher: Ponnaiyah Ramajayam Institute of Science and Technology (PRIST)

## TABLE OF CONTENT

S.NO	TOPICS	PAGE NO
1	Basics of C Program Dr.S.Nithyanadam	03
2	Control Structures Ms.S.Gayathri	40
3	Arrays and Strings Mr.K.Bhanumathi	73
4	Functions and Pointers Mr.K Bhanumathi	120
5	Structures and Unions Mr.K.Balamurali	140
6	File Processing Ms.K.Uma Shankar	150
7	Memory Management Ms.M.Jeeva	158
8	Multithreading in C Ms.s.Gayathri	165
9	Libraries and Standard Functions Ms.K.Balamurali	178
10	Debugging and Optimization Ms.S.Gayathiri	187
11	REFERENCE	200

# CHAPTER 1

## Basics of C Program

Dr.S.Nithyanadam

The basics of a C program cover the foundational elements you need to understand before diving into more complex topics. Let's break down these basics:

### Structure of a C Program

A basic C program follows a particular structure:

```
c
Copy code
#include <stdio.h> // Preprocessor directive to include standard I/O library

int main() { // The main function where program execution begins
    printf("Hello, World!\n"); // Print a message to the screen
    return 0; // Return value indicating successful program execution
}
```

*Key Parts:*

- **Preprocessor Directives (#include):**
  - This is used to include files or libraries before actual compilation starts. For example, #include <stdio.h> includes the standard input-output library, which allows using functions like printf.
- **Main Function (int main()):**
  - Every C program must have a main() function where the program execution begins. It returns an integer value, typically 0 for successful execution.
- **Statements (printf("Hello, World!\n")):**
  - Inside the main function, you write the instructions or statements to be executed. Here, printf() is used to print output.
- **Return Statement (return 0;):**
  - The return statement sends a value back to the operating system. 0 is returned if the program finishes successfully.

### Basic Elements of C

. Variables:

Variables are containers for storing data values.

```
c
Copy code
int a = 10; // Declare an integer variable and initialize it with 10
float b = 3.14; // Declare a float variable and initialize it
```

## CHAPTER 2

### Control Structures

Ms.S.Gayathiri

Control structures in C are used to control the flow of execution based on certain conditions or iterations. There are three main types of control structures in C:

1. **Conditional (Decision-Making) Statements:** Execute code based on conditions.
2. **Looping Statements:** Repeat code for a certain number of iterations or as long as a condition is true.
3. **Jump Statements:** Control the flow by breaking or continuing loops or transferring control elsewhere in the program.

#### Conditional (Decision-Making) Statements

##### if Statement

The if statement executes a block of code only if a specified condition is true.

```
c
Copy code
if (condition) {
    // Code to execute if the condition is true
}
```

##### Example:

```
c
Copy code
int a = 10;
if (a > 0) {
    printf("a is positive\n");
}
```

##### b. if-else Statement

The if-else statement allows you to execute one block of code if the condition is true, and another if it's false.

```
c
Copy code
if (condition) {
    // Code if condition is true
} else {
    // Code if condition is false
}
```

##### Example:

```
c
Copy code
int a = -5;
```



## CHAPTER 3

### Arrays and Strings

Ms.K.Bhanumathi

#### Arrays in C

An array is a collection of variables of the same type stored in contiguous memory locations. It allows storing multiple values in a single data structure.

#### Declaring and Initializing Arrays

Arrays can be declared and initialized as follows:

```
c
Copy code
type array_name[array_size];
```

#### Example:

```
int numbers[5]; // Declaring an integer array of size 5
```

#### Pointers in C

Pointers are variables that store the memory address of another variable.

```
int *p = &a; // Pointer p holds the address of variable a
```

#### 2.2 Dereferencing Pointers

The dereference operator `*` is used to access the value stored at the memory location pointed to by the pointer.

```
c
Copy code
int value = *p; // Dereference pointer p to get the value of a (which is 10)
```

#### Pointer Arithmetic

You can perform arithmetic operations on pointers to navigate through memory locations.

- **Incrementing a pointer:** Moves to the next memory location of the type the pointer points to.

```
c
Copy code
p++; // Move to the next integer memory location (if p is an int pointer)
```

- **Decrementing a pointer:** Moves to the previous memory location.

## CHAPTER 4

### Functions and Pointers

Ms.K.Bhanumathi

In C, functions and pointers are two powerful concepts, and when combined, they enable dynamic and flexible manipulation of data. Pointers allow you to pass references to variables, arrays, or even other functions to a function, enabling efficient memory usage and more complex behaviors like returning multiple values from a function.

### Function Basics in C

A function is a self-contained block of code that performs a specific task. It is used to improve code organization, reduce redundancy, and improve reusability.

Function Declaration (Prototype)

A function must be declared before it can be used. This is called the function prototype.

```
c
Copy code
return_type function_name(parameters);
```

### Example:

```
c
Copy code
int add(int a, int b); // Function prototype
Function Definition
```

The function definition provides the actual code for the function.

```
c
Copy code
return_type function_name(parameters) {
    // Function body
}
```

Function Call

Functions are called by their name, passing required arguments (if any).

```
c
Copy code
int result = add(5, 3); // Function call
```

### Pointers and Functions

Pointers can be passed to and returned from functions, providing the ability to manipulate data directly by reference, rather than by value.

## CHAPTER 5

### Structures and Unions

Ms.K.Balamurali

In C programming, **structures** and **unions** allow you to group variables of different types under a single name. They are essential for creating complex data types and efficient memory management.

#### Structures in C

A **structure** is a user-defined data type that allows grouping variables of different data types together. Each variable in a structure is called a **member**.

##### Defining a Structure

You define a structure using the `struct` keyword:

```
c
Copy code
struct structure_name {
    data_type member1;
    data_type member2;
    // More members
};
```

This defines a `Person` structure with three members: `name` (an array of 50 characters), `age` (an integer), and `height` (a floating-point number).

##### Declaring Structure Variables

Once a structure is defined, you can declare structure variables either by:

1. Declaring them along with the structure definition.
2. Declaring them separately.

##### Example:

```
c
Copy code
struct Person p1; // Declare a structure variable of type Person
```

You can also declare and initialize structure variables at the time of declaration:

```
c
Copy code
struct Person p1 = {"John Doe", 30, 5.9};
```

## CHAPTER 6

### File Processing

Ms.K.Uma Shankar

File processing allows programs to store and retrieve data from files on a disk. C provides a set of standard functions to handle file operations such as reading, writing, and appending data to files. Files in C can be handled in two ways: **Text mode** and **Binary mode**.

### Types of Files in C

1. **Text Files:** Stores data in human-readable form, with each line of data terminated by a newline character (\n).
2. **Binary Files:** Stores data in a format that is not human-readable, which saves memory and allows for faster data access and processing.

### File Handling Functions in C

To perform file operations in C, you typically use these standard functions provided by the `stdio.h` library:

- `fopen()`: Opens a file.
- `fclose()`: Closes a file.
- `fscanf()`, `fprintf()`: Reads and writes data to a file in text mode.
- `fread()`, `fwrite()`: Reads and writes data in binary mode.
- `fgetc()`, `fputc()`: Reads and writes single characters to/from a file.
- `fgets()`, `fputs()`: Reads and writes strings to/from a file.
- `feof()`: Checks the end of the file.
- `fseek()`, `tell()`, `rewind()`: Functions for file positioning.

### Opening and Closing Files

Before performing any operation on a file, it must be opened using the `fopen()` function. After the operations are complete, the file should be closed using `fclose()`.

`fopen()`

c

Copy code

```
FILE *fopen(const char *filename, const char *mode);
```

- **filename:** Name of the file to open.
- **mode:** Mode in which the file is opened. Common modes include:
  - "r": Open for reading (file must exist).
  - "w": Open for writing (creates a new file or truncates an existing one).
  - "a": Open for appending (writes data at the end of the file).
  - "rb", "wb", "ab": Same as "r", "w", and "a", but in binary mode.

## CHAPTER 7

### Memory Management

Ms.M.Jeeva

Memory management in C involves the allocation, manipulation, and deallocation of memory during the execution of a program. Efficient use of memory is critical to ensure the program runs optimally and prevents issues like memory leaks or segmentation faults.

#### Types of Memory Allocation

There are two main types of memory allocation in C:

1. **Static Memory Allocation:** Memory is allocated at compile-time.
2. **Dynamic Memory Allocation:** Memory is allocated at runtime using functions from the `stdlib.h` library.

#### Static Memory Allocation

In static memory allocation, memory for variables is allocated when the program starts and deallocated when the program ends. This type of memory is used for global variables, static variables, and arrays with fixed size.

#### Example:

```
c
Copy code
int arr[10]; // Static allocation, memory allocated at compile time
```

This method is inflexible because the size must be known at compile time.

#### Dynamic Memory Allocation

Dynamic memory allocation allows memory to be allocated and deallocated at runtime. This provides flexibility for data structures like linked lists, resizable arrays, and trees.

Dynamic memory is allocated using functions:

- `malloc()`: Allocates memory.
- `calloc()`: Allocates and initializes memory.
- `realloc()`: Reallocates memory (resizes previously allocated memory).
- `free()`: Frees allocated memory.

#### Dynamic Memory Allocation Functions

```
malloc()
void *malloc(size_t size);
```

## CHAPTER 8

### Multithreading in C

Ms.S.Gayathiri

Multithreading allows a program to perform multiple tasks concurrently, taking advantage of multiple CPU cores for better performance and responsiveness. In C, multithreading is commonly implemented using **POSIX Threads** (Pthreads), which is a POSIX standard for thread management

#### What is a Thread?

A thread is a lightweight, independent unit of a process. Multiple threads can exist within the same process and share the same resources (e.g., memory space), making communication between threads faster and more efficient than between processes.

- **Main Thread:** Every C program has at least one thread, the **main thread**, which starts the program execution.
- **Worker Threads:** Additional threads created during execution.

#### POSIX Threads (Pthreads)

The **POSIX Threads (Pthreads)** library provides functions to create and manage threads in C. To use Pthreads, you need to include the header file `pthread.h`.

To compile programs with Pthreads on Unix-like systems (Linux, macOS), you link with the pthread library using `-pthread`:

```
bash
```

```
Copy code
```

```
gcc -pthread program.c -o progra
```

### 3. Creating and Managing Threads

#### 3.1 pthread\_create()

```
c
```

```
Copy code
```

```
int pthread_create(pthread_t *thread, const pthread_attr_t *attr, void *(*start_routine)(void *), void *arg);
```

- **thread:** Pointer to the thread identifier (of type `pthread_t`).
- **attr:** Pointer to a thread attributes object (can be NULL for default attributes).
- **start\_routine:** The function to be executed by the thread.
- **arg:** Argument to be passed to the `start_routine` function.

#### Example: Creating a thread

```
c
```

```
Copy code
```

```
#include <stdio.h>
```

## CHAPTER 9

### Libraries and Standard Functions

Ms.K.Balamurali

C programming relies heavily on libraries and standard functions to simplify tasks and perform common operations. These libraries provide pre-written code to handle input/output (I/O), string manipulation, memory management, and mathematical calculations, among other things.

### Standard C Libraries

There are several standard libraries available in C. Each library contains a collection of functions that cater to different types of operations. Below are some key C libraries and their functionalities:

<stdio.h> (Standard Input/Output Library)

The **Standard Input/Output Library** provides functions for input and output operations, such as reading from and writing to the console or files.

Common functions:

- printf(): Prints formatted output to the console.
- scanf(): Reads formatted input from the console.
- fopen(): Opens a file.
- fclose(): Closes a file.
- fgets(): Reads a line from a file or console.
- fputc(): Writes a character to a file.

<stdlib.h> (Standard Library)

The **Standard Library** provides functions for memory allocation, process control, conversions, and random number generation.

Common functions:

- malloc(): Allocates dynamic memory.
- free(): Frees dynamically allocated memory.
- atoi(): Converts a string to an integer.
- rand(): Generates a random number.
- exit(): Exits a program.

### Example: Using malloc() and free()

```
c
Copy code
#include <stdio.h>
#include <stdlib.h>
```

## CHAPTER 10

### Debugging and Optimization

Ms.S.Gayathiri

Debugging and optimization are crucial aspects of programming that ensure your C programs run correctly and efficiently. Here's a comprehensive overview of both topics:

#### Debugging

Debugging is the process of finding and fixing errors or bugs in your code. Common types of errors include syntax errors, runtime errors, and logical errors.

#### Tools and Techniques

##### 1. Print Statements

Adding `printf()` statements to output variable values and program flow can help identify issues.

```
c
Copy code
printf("Value of x: %d\n", x);
```

##### 2. Debuggers

Debuggers provide more advanced capabilities, such as setting breakpoints, stepping through code, and inspecting variables. Some popular debuggers include:

- **GDB (GNU Debugger):** A powerful command-line debugger for C programs.
- **LLDB:** A debugger used with the LLVM project.
- **IDE Debuggers:** Integrated debuggers in IDEs like Code::Blocks, Eclipse, and Visual Studio.

##### 3. Valgrind

Valgrind is a tool for detecting memory leaks and memory management issues.

```
bash
Copy code
valgrind --leak-check=full ./program
```

##### 4. Sanitizers

**AddressSanitizer (ASan)** and **UndefinedBehaviorSanitizer (UBSan)** are tools that help detect memory corruption and undefined behavior, respectively.

#### Example Usage:

```
bash
```



# PROBLEM SOLVING AND PYTHON PROGRAMMING

EDITED BY

DR.S.NITHYANANDAM



978-93-6255-081-1

PROBLEM SOLVING AND PYTHON PROGRAMMING

Copyright © 2018 By Dr.S.Nithyanadam

All rights reserved. No part of this book may be reproduced or transmitted in any form or by any means without written permission from the author.

ISBN:978-93-6255-081-1

Publisher: Ponnaiyah Ramajayam Institute of Science and Technology (PRIST)

## TABLE OF CONTENT

S.NO	TOPICS	PAGE NO
1	Computational Thinking and Problem solving Dr.S.Nithyanadam	03
2	Data Types and Expressions Dr.S.Nithyanadam	40
3	Control Flow ,Functions,String Dr.S.Nithyanadam	73
4	Lists,Tuples,Dictionaries Dr.S.Nithyanadam	120
5	Linked Lists Mr.K.Balamurali	140
6	OOPS Concept Ms.K.Uma Shankar	150
7	Exception Handling Ms.M.Jeeva	158
8	Web Scraping and APIs Ms.s.Gayathri	165
9	Greedy Algorithms Ms.K.Balamurali	178
10	Files modules ,Packages Ms.S.Gayathiri	187
11	REFERENCE	200

# CHAPTER 1

## Computational Thinking and problem solving

Dr.S.Nithyanandam

**Computational Thinking** is a problem-solving process that includes a number of characteristics and dispositions. It involves breaking down complex problems into manageable parts and solving them using algorithms, data structures, and logical reasoning. **Problem-solving** in this context refers to applying these techniques to develop efficient and effective solutions.

### Decomposition

- **Definition:** Breaking a complex problem into smaller, more manageable components.
- **Purpose:** To simplify and focus on one aspect of the problem at a time.
- **Example:** Decomposing a project into tasks and subtasks. **Pattern Recognition**
- **Definition:** Identifying similarities or patterns in problems and solutions.
- **Purpose:** To apply known solutions to new problems that share similar characteristics.
- **Example:** Recognizing that sorting algorithms can be used for different types of data.

### Abstraction

- **Definition:** Simplifying complex systems by focusing on high-level concepts.
- **Purpose:** To manage complexity and make problems easier to solve.
- **Example:** Using a high-level description of a problem rather than getting bogged down by implementation details.

### Algorithm Design

- **Definition:** Creating a step-by-step procedure to solve a problem.
- **Purpose:** To develop clear and effective solutions that can be implemented in code.
- **Example:** Designing a sorting algorithm to organize a list of numbers.

### Problem Solving Strategies

- **Trial and Error:** Testing different solutions until one works.
- **Divide and Conquer:** Breaking the problem into smaller parts, solving each part, and combining solutions.
- **Greedy Approach:** Making the most favorable choice at each step.
- **Dynamic Programming:** Solving problems by breaking them into overlapping subproblems and storing solutions.
- **Backtracking:** Exploring possible solutions and backtracking when a solution is not feasible.

# CHAPTER 2

## Data Types, Expressions, Statements

Dr.S.Nithyanandam

### Data Types

**Data types** define the kind of data that can be stored and manipulated within a program. Python supports several built-in data types:

#### Basic Data Types

##### 1. Integers (int)

- Whole numbers, positive or negative.
- Example: 5, -3, 0

### Expressions

**Expressions** are combinations of variables, literals, operators, and function calls that are evaluated to produce a value.

#### Arithmetic Expressions

Perform mathematical operations.

- **Addition (+):**  $a + b$
- **Subtraction (-):**  $a - b$
- **Multiplication (\*):**  $a * b$
- **Division (/):**  $a / b$  (returns a float)
- **Integer Division (//):**  $a // b$  (returns an integer)
- **Modulus (%):**  $a \% b$  (returns the remainder)
- **Exponentiation (\*\*):**  $a ** b$  (a raised to the power of b)

```
python
Copy code
result = 10 + 5 * 2 # result is 20
```

#### Comparison Expressions

Compare values and return Boolean results.

- **Equal to (==):**  $a == b$
- **Not equal to (!=):**  $a != b$
- **Greater than (>):**  $a > b$
- **Less than (<):**  $a < b$
- **Greater than or equal to (>=):**  $a >= b$
- **Less than or equal to (<=):**  $a <= b$

## CHAPTER 3

### Control Flow, Functions, String

Dr.S.Nithyanandam

Control flow refers to the order in which individual statements, instructions, or function calls are executed or evaluated in a programming language. Control flow mechanisms allow a program to make decisions, repeat operations, and jump to different sections of code based on certain conditions.

#### Key Control Flow Mechanisms

- **Sequential Execution:** Code is executed line by line, from top to bottom.
- **Conditional Statements:** if, else if, and else statements allow code to be executed based on specific conditions.
- **Loops:** for, while, and do...while loops enable repetitive execution of code blocks.
- **Function Calls:** Functions are invoked based on the program's flow and the logic defined.
- **Exception Handling:** try, catch, and finally blocks manage errors and exceptions in the program.

#### Controlling Function Calls with Control Flow

Function calls are integral to the control flow in programming. They enable modular and reusable code. By controlling when and how functions are called, you can manage the complexity of your program.

##### Sequential Function Calls

In sequential execution, functions are called one after another in the order they are written.

Control flow in Node.js is typically managed using one of three methods: **callbacks**, **promises**, and **async/await**.

#### Callbacks

Callbacks are functions that are passed as arguments to other functions and are executed when that function completes its task. In Node.js, many functions are asynchronous, and they often take a callback as an argument. When the asynchronous operation is completed, the callback is **executed, allowing the program to continue its execution.**

#### Steps to use a callback

- Define the function that accepts a callback parameter. This function should perform some asynchronous operation and then call the callback with the result.

## CHAPTER 4

### Lists, Tuples, Dictionaries

Dr.S.Nithyanandam

Python has several other important data types that you'll probably use every day. They are called lists, tuples and dictionaries. This chapter's aim is to get you acquainted with each of these data types. They are not particularly complicated, so I expect that you will find learning how to use them very straight forward. Once you have mastered these three data types plus the string data type from the previous chapter, you will be quite a ways along in your education of Python. You'll be using these four building blocks in 99% of all the applications you will write.

#### Lists

A Python list is similar to an array in other languages. In Python, an empty list can be created in the following ways.

```
>>> my_list = []
>>> my_list = list()
```

As you can see, you can create the list using square brackets or by using the Python built-in, **list**. A list contains a list of elements, such as strings, integers, objects or a mixture of types. Let's take a look at some examples:

```
>>> my_list = [1, 2, 3]
>>> my_list2 = ["a", "b", "c"]
>>> my_list3 = ["a", 1, "Python", 5]
```

#### Tuples

A tuple is similar to a list, but you create them with parentheses instead of square brackets. You can also use the **tuple** built-in. The main difference is that a tuple is immutable while the list is mutable. Let's take a look at a few examples:

```
>>> my_tuple = (1, 2, 3, 4, 5)
>>> my_tuple[0:3]
(1, 2, 3)
>>> another_tuple = tuple()
```

## CHAPTER 5

### Linked List

Mr.K.Balamurali

A linked list is a type of linear data structure similar to arrays. It is a collection of nodes that are linked with each other. A node contains two things first is data and second is a link that connects it with another node. Below is an example of a linked list with four nodes and each node contains character data and a link to another node. Our first node is where **head** points and we can access all the elements of the linked list using the **head**.

#### Creating a linked list in Python

In this LinkedList class, we will use the Node class to create a linked list. In this class, we have an **\_\_init\_\_** method that initializes the linked list with an empty head. Next, we have created an **insertAtBegin()** method to insert a node at the beginning of the linked list, an **insertAtIndex()** method to insert a node at the given index of the linked list, and **insertAtEnd()** method inserts a node at the end of the linked list. After that, we have the **remove\_node()** method which takes the data as an argument to delete that node. In the **remove\_node()** method we traverse the linked list if a node is present equal to data then we delete that node from the linked list. Then we have the **sizeOfLL()** method to get the current size of the linked list and the last method of the LinkedList class is **printLL()** which traverses the linked list and prints the data of each node.

#### Creating a Node Class

We have created a Node class in which we have defined a **\_\_init\_\_** function to initialize the node with the data passed as an argument and a reference with None because if we have only one node then there is nothing in its reference.

Python

```
class Node:
    def __init__(self, data):
        self.data = data
        self.next = None
```



## CHAPTER 6

### OOPs Concept

Ms.K.Uma Shankar

Object-Oriented Programming (OOP) is a programming paradigm centered around objects rather than actions. Objects are instances of classes, which can encapsulate data and behavior. OOP principles help in organizing and structuring code in a way that enhances reusability, scalability, and maintainability.

**Here are the core concepts of OOP:**

#### Classes and Objects

##### Class

A class is a blueprint for creating objects. It defines a data structure that contains data members (attributes) and methods (functions) that operate on the data.

```
python
Copy code
class Car:
    def __init__(self, make, model):
        self.make = make
        self.model = model

    def display_info(self):
        print(f"{self.make} {self.model}")
```

##### Object

An object is an instance of a class. It represents a specific entity with data and behavior defined by the class.

```
python
Copy code
my_car = Car("Toyota", "Corolla")
my_car.display_info() # Output: Toyota Corolla
```

#### Encapsulation

Encapsulation is the concept of bundling data (attributes) and methods (functions) that operate on the data into a single unit, i.e., a class. It also involves restricting direct access to some of the object's components, which is achieved using access modifiers.

- **Public:** Attributes and methods are accessible from outside the class.

## CHAPTER 7

### Exception Handling

Ms.M.Jeeva

In Python, there are several built-in Python exceptions that can be raised when an error occurs during the execution of a program. Here are some of the most common types of exceptions in Python:

- **SyntaxError:** This exception is raised when the interpreter encounters a syntax error in the code, such as a misspelled keyword, a missing colon, or an unbalanced parenthesis.
- **TypeError:** This exception is raised when an operation or function is applied to an object of the wrong type, such as adding a string to an integer.
- **NameError:** This exception is raised when a variable or function name is not found in the current scope.
- **IndexError:** This exception is raised when an index is out of range for a list, tuple, or other sequence types.
- **KeyError:** This exception is raised when a key is not found in a dictionary.
- **ValueError:** This exception is raised when a function or method is called with an invalid argument or input, such as trying to convert a string to an integer when the string does not represent a valid integer.
- **AttributeError:** This exception is raised when an attribute or method is not found on an object, such as trying to access a non-existent attribute of a class instance.
- **IOError:** This exception is raised when an I/O operation, such as reading or writing a file, fails due to an input/output error.
- **ZeroDivisionError:** This exception is raised when an attempt is made to divide a number by zero.
- **ImportError:** This exception is raised when an import statement fails to find or load a module.

These are just a few examples of the many types of exceptions that can occur in Python. It's important to handle exceptions properly in your code using try-except blocks or other error-handling techniques, in order to gracefully handle errors and prevent the program from crashing.

Difference between Syntax Error and Exceptions

**Syntax Error:** As the name suggests this error is caused by the wrong syntax in the code. It leads to the termination of the program.

**Example:**

There is a syntax error in the code . The **'if'** statement should be followed by a colon (:), and the **'print'** statement should be indented to be inside the **'if'** block.

Python

```
amount = 10000
if(amount > 2999)
```

## **CHAPTER 8**

### **Web Scraping and APIs**

Ms.S.Gayathiri

**Web scraping** is a powerful technique used to extract data from websites. It involves automating the process of accessing web pages, fetching the relevant information, and saving it for further analysis or integration into other systems. In simple terms, it's like having an automated bot that visits web pages, reads the content, and collects the data you need. A good example of web scraping is scraping product data to build price comparison websites. Web scraping provides direct access to the data.

To understand the intricacies of web scraping and its role in data extraction, it's important to delve deeper into the process. Firstly, a web scraping tool or script is meticulously developed, carefully considering the target website and the specific data that needs to be scraped. This tool acts as the conduit between the user and the desired information, enabling a seamless extraction process.

The next step involves sending an **HTTP request** to the target website server. This request serves as a virtual knocking on the server's door, requesting access to the HTML code of the web page in question. Upon approval, the server obliges by providing the requested HTML code, which serves as a digital blueprint containing the structural layout, content, and multitude of elements present on the page.

The beauty of web scraping lies in its ability to navigate through this sea of HTML code with finesse, extracting the desired data points with surgical precision. Guided by the specified instructions within the scraping tool, the underlying algorithm meticulously combs through the HTML code, honing in on the designated data elements. This process involves leveraging powerful parsing techniques to pinpoint and extract the required data, ensuring a robust and accurate output.

**APIs**, which stands for Application Programming Interfaces, are powerful tools that facilitate communication and interaction between different software applications. They act as intermediaries, allowing developers to access and use data or functionality from other systems without starting from scratch. Essentially, APIs provide a standardized way for applications to seamlessly exchange information.

## CHAPTER 9

### Greedy Algorithms

Ms.S.Gayathiri

A greedy algorithm is an approach for solving a problem by selecting the best option available at the moment. It doesn't worry whether the current best result will bring the overall optimal result.

The algorithm never reverses the earlier decision even if the choice is wrong. It works in a top-down approach.

However, we can determine if the algorithm can be used with any problem if the problem has the following properties:

#### 1. Greedy Choice Property

If an optimal solution to the problem can be found by choosing the best choice at each step without reconsidering the previous steps once chosen, the problem can be solved using a greedy approach. This property is called greedy choice property.

#### 2. Optimal Substructure

If the optimal overall solution to the problem corresponds to the optimal solution to its subproblems, then the problem can be solved using a greedy approach. This property is called optimal substructure.

#### Advantages of Greedy Approach

- The algorithm is **easier to describe**.
- This algorithm can **perform better** than other algorithms (but, not in all cases).

#### Drawback of Greedy Approach

As mentioned earlier, the greedy algorithm doesn't always produce the optimal solution. This is the major disadvantage of the algorithm.

For example, suppose we want to find the longest path in the graph below from root to leaf. Let's use the greedy algorithm here.

#### Greedy Approach

1. Let's start with the root node **20**. The weight of the right child is **3** and the weight of the left child is **2**.

2. Our problem is to find the largest path. And, the optimal solution at the moment is **3**. So, the greedy algorithm will choose **3**.

3. Finally the weight of an only child of **3** is **1**. This gives us our final result  $20 + 3 + 1 = 24$ .

However, it is not the optimal solution. There is another path that carries more weight ( $20 + 2 + 10 = 32$ ) as shown in the image below.

# CHAPTER 10

## Files, Modules, Packages

Ms.K.Sangeetha

### Files

A file in Python is a collection of data or information stored on a computer device. Files can be categorized as text or binary.

### Modules

A module is a file that contains Python code and has a .py extension. To import a module, use the import statement. For example, to import a module named mymodule, you can use the code import mymodule.

### Packages

A package is a collection of modules that are contained within a directory and an \_\_init\_\_.py file. To import a package, use the code import package\_name.module\_name.

**Here are some examples of files, modules, and packages in Python:**

#### Example of a module

A module named mymodule can contain a function and a dictionary. For example, the function greeting() can print a greeting message, and the dictionary person1 can contain a **person's name, age, and country.**

#### Example of a package

A package can be created for a calculator application by creating a directory named calculator, **and then creating an \_\_init\_\_.py file and modules within it.**

#### Example of importing a module

To import the calculation module and access the add() function, you can use the code import calculation and print(calculation.add(1,2)).

To use the functionality present in any module, you have to import it into your current program. You need to use the `import` keyword along with the desired module name. When the interpreter comes across an `import` statement, it imports the module to your current program. You can use the functions inside a module by using a dot (.) operator along with the module name. First, let's see how to use the standard library modules. In the example below, the `math` module is imported into the program so that you can use the `sqrt()` function.



# FUNDAMENTALS OF BIOLOGICAL

Edited by  
**DR. ARJUN PANDIAN**



978-93-6255-130-6

**FUNDAMENTALS OF BIOLOGICAL**  
**Copyright © 2018 by Dr. Arjunpandian**

**All rights reserved. No part of this book may be reproduced or transmitted in any form or by any means without written permission from the author.**

**ISBN: 978-93-6255-130-6**

**Publisher: Ponnaiyah Ramajayam Institute of Science and Technology  
(PRIST)**

## TABLE OF CONTENTS

<b>CHAPTER 1 - Cell biology.....</b>	<b>01</b>
<b>Dr. ARJUN PANDIAN</b>	
<b>CHAPTER 2 – Biochemistry.....</b>	<b>12</b>
<b>Dr. P. MANONMANI</b>	
<b>CHAPTER 3 - Bacteriology.....</b>	<b>27</b>
<b>Dr. T. VEERAMANI</b>	
<b>CHAPTER 4 – Ecology.....</b>	<b>42</b>
<b>Ms. J. ILAMATHI</b>	
<b>CHAPTER 5 - Environmental science.....</b>	<b>57</b>
<b>Dr. C. ANUSHIA</b>	
<b>CHAPTER 6 – Biostatistics.....</b>	<b>72</b>
<b>Dr. ARJUN PANDIAN</b>	
<b>CHAPTER 7 – Botany.....</b>	<b>86</b>
<b>Dr. T. VEERAMANI</b>	
<b>CHAPTER 8 – Neuroscience.....</b>	<b>101</b>
<b>Dr. R. ARUNKUMAR</b>	
<b>CHAPTER 9 – Genetics.....</b>	<b>115</b>
<b>Dr. A. SHAJAHAN</b>	
<b>CHAPTER 10 – Agriculture.....</b>	<b>130</b>
<b>Mr. G. RAJENDRAN</b>	
<b>REFERENCES .....</b>	<b>145</b>



# CHAPTER 1

## CELL BIOLOGY

**Dr. ARJUN PANDIAN**

*Associate Professor, Department of Biotechnology  
Ponnaiyah Ramajayam Institute of Science and Technology*

### **CELL BIOLOGY**

Cell biology (also cellular biology or cytology) is a branch of biology that studies the structure, function, and behaviour of cells. All living organisms are made of cells. A cell is the basic unit of life that is responsible for the living and functioning of organisms. Cell biology is the study of the structural and functional units of cells. Cell biology encompasses both prokaryotic and eukaryotic cells and has many subtopics which may include the study of cell metabolism, cell communication, cell cycle, biochemistry, and cell composition. The study of cells is performed using several microscopy techniques, cell culture, and cell fractionation. These have allowed for and are currently being used for discoveries and research pertaining to how cells function, ultimately giving insight into understanding larger organisms. Knowing the components of cells and how cells work is fundamental to all biological sciences while also being essential for research in biomedical fields such as cancer, and other diseases. Research in cell biology is interconnected to other fields such as genetics, molecular genetics, molecular biology, medical microbiology, immunology, and cytochemistry.

The starting point for this discipline might be considered the 1830s. Though scientists had been using microscopes for centuries, they were not always sure what they were looking at. Robert Hooke's initial observation in 1665 of plant-cell walls in slices of cork was followed shortly by Antonie van Leeuwenhoek's first descriptions of live cells with visibly moving parts. In the 1830s two scientists who were colleagues — Schleiden, looking at plant cells, and Schwann, looking first at animal cells — provided the first clearly stated definition of the cell. Their definition stated that that all living creatures, both simple and complex, are made out of one or more cells, and the cell is the structural and functional unit of life — a concept that became known as cell theory.

As microscopes and staining techniques improved over the nineteenth and twentieth centuries, scientists were able to see more and more internal detail within cells. The microscopes used by van Leeuwenhoek probably magnified specimens a few hundredfold.

## CHAPTER 2

# BIOCHEMISTRY

**Dr. P. MANONMANI**

*Professor, Department of Biotechnology  
Ponnaiyah Ramajayam Institute of Science and Technology*

### **BIOCHEMISTRY**

Biochemistry or biological chemistry is the study of [chemical processes](#) within and relating to living [organisms](#). A sub-discipline of both [chemistry](#) and [biology](#), biochemistry may be divided into three fields: [structural biology](#), [enzymology](#), and [metabolism](#). Over the last decades of the 20th century, biochemistry has become successful at explaining living processes through these three disciplines. Almost all [areas of the life sciences](#) are being uncovered and developed through biochemical methodology and research.

Biochemistry focuses on understanding the chemical basis which allows [biological molecules](#) to give rise to the processes that occur within living [cells](#) and between cells, in turn relating greatly to the understanding of [tissues](#) and [organs](#) as well as organism structure and function. Biochemistry is closely related to [molecular biology](#), the study of the [molecular](#) mechanisms of biological phenomena.

Much of biochemistry deals with the structures, functions, and interactions of biological [macromolecules](#) such as [proteins](#), [nucleic acids](#), [carbohydrates](#), and [lipids](#). They provide the structure of cells and perform many of the functions associated with life.

The chemistry of the cell also depends upon the reactions of small [molecules](#) and [ions](#). These can be [inorganic](#) (for example, [water](#) and [metal](#) ions) or [organic](#) (for example, the [amino acids](#), which are used to [synthesize proteins](#)). The mechanisms used by [cells to harness energy](#) from their environment via [chemical reactions](#) are known as [metabolism](#). The findings of biochemistry are applied primarily in [medicine](#), [nutrition](#) and [agriculture](#).

In medicine, [biochemists](#) investigate the causes and [cures](#) of [diseases](#). Nutrition studies how to maintain health and wellness and also the effects of [nutritional deficiencies](#). In agriculture, biochemists investigate [soil](#) and [fertilizers](#) with the goal of improving crop cultivation, crop storage, and [pest control](#).

In recent decades, biochemical principles and methods have been combined with problem-solving approaches from [engineering](#) to manipulate living systems in order to produce useful

## **CHAPTER 3**

### **BACTERIOLOGY**

**Dr. T. VEERAMANI**

*Research Associate, Department of Biotechnology  
Bharathidasan University, Trichy*

## **BACTERIOLOGY**

Bacteriology is the branch and specialty of biology that studies the morphology, ecology, genetics and biochemistry of bacteria as well as many other aspects related to them. This subdivision of microbiology involves the identification, classification, and characterization of bacterial species. Because of the similarity of thinking and working with microorganisms other than bacteria, such as protozoa, fungi, and viruses, there has been a tendency for the field of bacteriology to extend as microbiology. The terms were formerly often used interchangeably. However, bacteriology can be classified as a distinct science.

Bacteria are single-celled microorganisms that lack a nuclear membrane, are metabolically active and divide by binary fission. Medically they are a major cause of disease. Superficially, bacteria appear to be relatively simple forms of life; in fact, they are sophisticated and highly adaptable. Many bacteria multiply at rapid rates, and different species can utilize an enormous variety of hydrocarbon substrates, including phenol, rubber, and petroleum. These organisms exist widely in both parasitic and free-living forms. Because they are ubiquitous and have a remarkable capacity to adapt to changing environments by selection of spontaneous mutants, the importance of bacteria in every field of medicine cannot be overstated.

The discipline of bacteriology evolved from the need of physicians to test and apply the germ theory of disease and from economic concerns relating to the spoilage of foods and wine. The initial advances in pathogenic bacteriology were derived from the identification and characterization of bacteria associated with specific diseases. During this period, great emphasis was placed on applying Koch's postulates to test proposed cause-and-effect relationships between bacteria and specific diseases. Today, most bacterial diseases of humans and their etiologic agents have been identified, although important variants continue to evolve and sometimes emerge, e.g., Legionnaire's Disease, tuberculosis and toxic shock syndrome.

These chapters provide the basis for the next chapters devoted to specific bacterial pathogens and the diseases they cause. The bacteria in these chapters are grouped on the basis of physical, chemical, and biologic characteristics. These similarities do not necessarily indicate that their diseases are similar; widely divergent diseases may be caused by bacteria in the same group.

## **CHAPTER 4**

### **ECOLOGY**

**Ms. J. ILAMATHI**

*Assistant Professor, Department of Biotechnology  
Ponnaiyah Ramajayam Institute of Science and Technology*

### **ECOLOGY**

Ecology is a vital field that explores the intricate relationships between living organisms—humans included—and their environments. It encompasses various levels of organization, from individual organisms to entire biospheres, and intersects with other disciplines like biogeography and evolutionary biology.

At its core, ecology examines how organisms interact with each other and with their physical surroundings. This includes studying patterns of biodiversity, ecosystem processes like energy flow and nutrient cycling, and the dynamics of cooperation, competition, and predation.

The practical implications of ecology are significant, impacting fields such as conservation biology, urban planning, and resource management. Understanding ecological principles helps us address challenges like climate change, habitat loss, and resource depletion.

The term "ecology" was introduced by Ernst Haeckel in 1866, but the formal study of ecology began to take shape in the late 19th century through the work of American botanists. Today, evolutionary concepts, particularly adaptation and natural selection, are fundamental to ecological theory.

Ecosystems are complex systems where biotic (living) and abiotic (non-living) components interact dynamically. These interactions support essential life-sustaining functions, provide vital ecosystem services—such as food production, climate regulation, and water filtration—and play a crucial role in maintaining the planet's health. Understanding these systems is key to ensuring their sustainability for future generations.

## **CHAPTER 5**

### **ENVIRONMENTAL SCIENCE**

**Dr. C. ANUSHIA**

*Associate Professor, Department of Biotechnology  
Ponnaiyah Ramajayam Institute of Science and Technology*

### **ENVIRONMENTAL SCIENCE**

Environmental science is an interdisciplinary field that combines knowledge from physics, biology, chemistry, geography, and other disciplines to address complex environmental issues. It emerged from natural history and medicine during the Enlightenment and gained prominence in the 1960s and 1970s, spurred by growing public awareness and the introduction of environmental laws.

This field employs a quantitative and integrated approach to study the Earth's physical, chemical, and biological processes. Environmental scientists analyze systems and their interactions to understand pressing issues such as pollution, resource management, and climate change. By considering how these various processes affect one another, they can develop effective strategies for mitigating environmental problems.

Environmental studies extend this understanding to include social sciences, examining human perceptions and policies related to the environment. Meanwhile, environmental engineering focuses on technological solutions to enhance environmental quality.

The rise of environmental science reflects the necessity for a multidisciplinary approach in tackling complex environmental challenges, fostering collaboration across fields to drive meaningful change and promote sustainability. Key developments, such as Rachel Carson's *Silent Spring*, have significantly influenced public consciousness and the evolution of environmental policies.

## **CHAPTER 6**

### **BIostatistics**

**Dr. ARJUN PANDIAN**

*Associate Professor, Department of Biotechnology  
Ponnaiyah Ramajayam Institute of Science and Technology*

## **BIostatistics**

Biostatistics, or biometry, plays a crucial role in the intersection of statistics and biological sciences, focusing on the design, analysis, and interpretation of experiments in fields like medicine, biology, and public health. Since the early 20th century, it has become essential for improving health outcomes and understanding disease dynamics.

This field is closely intertwined with epidemiology, which examines the distribution, causes, and control of diseases in populations. Although distinct, the two fields share methodologies; biostatistics provides the statistical tools needed to analyze epidemiological data.

If you're pursuing a biostatistics degree with an emphasis on epidemiology, expect to take specialized courses in epidemiological principles, infectious disease epidemiology, and statistical methods tailored for this area. This focus prepares you to tackle health-related research issues effectively.

Alternatively, if you aim to explore broader scientific research opportunities, a general biostatistics track—like mathematical statistics—might suit you better. This path typically includes advanced coursework in statistical inference and modeling, providing a deeper understanding of inferential techniques used across various scientific disciplines.

## **CHAPTER 7**

### **BOTANY**

**Dr. T. VEERAMANI**

*Research Associate, Department of Biotechnology  
Bharathidasan University, Trichy*

### **BOTANY**

Botany, also called plant science (or plant sciences), plant biology or phytology, is the science of plant life and a branch of biology. A botanist, plant scientist or phytologist is a scientist who specialises in this field. The term "botany" comes from the Ancient Greek word βοτάνη (botanē) meaning "pasture", "herbs" "grass", or "fodder"; βοτάνη is in turn derived from βόσκειν (boskein), "to feed" or "to graze".

Traditionally, botany has also included the study of fungi and algae by mycologists and phycologists respectively, with the study of these three groups of organisms remaining within the sphere of interest of the International Botanical Congress. Nowadays, botanists (in the strict sense) study approximately 410,000 species of land plants, including some 391,000 species of vascular plants (of which approximately 369,000 are flowering plants) and approximately 20,000 bryophytes.

Botany originated in prehistory as herbalism with the efforts of early humans to identify – and later cultivate – plants that were edible, poisonous, and possibly medicinal, making it one of the first endeavours of human investigation. Medieval physic gardens, often attached to monasteries, contained plants possibly having medicinal benefit. They were forerunners of the first botanical gardens attached to universities, founded from the 1540s onwards. One of the earliest was the Padua botanical garden. These gardens facilitated the academic study of plants. Efforts to catalogue and describe their collections were the beginnings of plant taxonomy and led in 1753 to the binomial system of nomenclature of Carl Linnaeus that remains in use to this day for the naming of all biological species.

In the 19th and 20th centuries, new techniques were developed for the study of plants, including methods of optical microscopy and live cell imaging, electron microscopy, analysis of chromosome number, plant chemistry and the structure and function of enzymes and other proteins. In the last two decades of the 20th century, botanists exploited the techniques of molecular genetic analysis, including genomics and proteomics and DNA sequences to classify plants more accurately.

## **CHAPTER 8**

### **NEUROSCIENCE**

**Dr. R. ARUNKUMAR**

*Assistant Professor, Department of Biotechnology  
Ponnaiyah Ramajayam Institute of Science and Technology*

### **NEUROSCIENCE**

Neuroscience is a comprehensive field dedicated to the study of the nervous system, encompassing the brain, spinal cord, and peripheral nervous system. As a multidisciplinary science, it integrates various domains such as physiology, anatomy, psychology, computer science, and even statistics to explore the intricate workings of neurons, glia, and neural circuits.

The scope of neuroscience has expanded to incorporate diverse methodologies, from molecular and cellular studies to advanced imaging techniques that analyze sensory, motor, and cognitive processes in the brain. This enables researchers to investigate the nervous system at multiple levels, from the micro (individual neurons) to the macro (whole brain functions).

At its core, neuroscience seeks to understand how the nervous system operates in health and disease, focusing primarily on the brain's role in learning, memory, perception, and consciousness. With around 86 billion neurons, neuroscientists examine how these cells interconnect and function, revealing the complexities behind thoughts, movements, and behaviors.

Institutions like King's Neuroscience are at the forefront of this research, aiming to uncover the developmental pathways of the nervous system and the mechanisms behind various disorders, from childhood epilepsy to Alzheimer's disease. By leveraging new technologies and interdisciplinary approaches, they strive to advance treatments and enhance our understanding of neurological conditions.



## CHAPTER 9

### GENETICS

**Dr. A. SHAJAHAN**

*Assistant Professor, Department of Biotechnology  
Ponnaiyah Ramajayam Institute of Science and Technology*

## GENETICS

Genetics is the study of [genes](#), [genetic variation](#), and [heredity](#) in [organisms](#). It is an important branch in [biology](#) because heredity is vital to organisms' [evolution](#). [Gregor Mendel](#), a [Moravian Augustinian](#) friar working in the 19th century in [Brno](#), was the first to study genetics scientifically. Mendel studied "trait inheritance", patterns in the way traits are handed down from parents to offspring over time. He observed that organisms (pea plants) inherit traits by way of discrete "units of inheritance". This term, still used today, is a somewhat ambiguous definition of what is referred to as a gene.

[Trait](#) inheritance and [molecular](#) inheritance mechanisms of genes are still primary principles of genetics in the 21st century, but modern genetics has expanded to study the function and behaviour of genes. Gene structure and function, variation, and distribution are studied within the context of the [cell](#), the organism (e.g. [dominance](#)), and within the context of a population. Genetics has given rise to a number of subfields, including [molecular genetics](#), [epigenetics](#), and [population genetics](#). Organisms studied within the broad field span the domains of life ([archaea](#), [bacteria](#), and [eukarya](#)).

Genetic processes work in combination with an organism's environment and experiences to influence development and [behaviour](#), often referred to as [nature versus nurture](#). The [intracellular](#) or [extracellular](#) environment of a living cell or organism may increase or decrease gene transcription. A classic example is two seeds of genetically identical corn, one placed in a [temperate climate](#) and one in an [arid climate](#) (lacking sufficient waterfall or rain). While the average height the two corn stalks could grow to is genetically determined, the one in the arid climate only grows to half the height of the one in the temperate climate due to lack of water and nutrients in its environment. Genetics, study of heredity in general and of genes in particular. Genetics forms one of the central pillars of biology and overlaps with many other areas, such as agriculture, medicine, and biotechnology.

## **CHAPTER 10**

### **AGRICULTURE**

**Mr. G. RAJENDRAN**

*Assistant Professor, Department of Biotechnology  
Ponnaiyah Ramajayam Institute of Science and Technology*

### **AGRICULTURE**

Agriculture encompasses crop and livestock production, aquaculture, and forestry for food and non-food products. Agriculture was a key factor in the rise of sedentary human civilization, whereby farming of domesticated species created food surpluses that enabled people to live in cities. While humans started gathering grains at least 105,000 years ago, nascent farmers only began planting them around 11,500 years ago. Sheep, goats, pigs, and cattle were domesticated around 10,000 years ago. Plants were independently cultivated in at least 11 regions of the world. In the 20th century, industrial agriculture based on large-scale monocultures came to dominate agricultural output.

As of 2021, small farms produce about one-third of the world's food, but large farms are prevalent. The largest 1% of farms in the world are greater than 50 hectares (120 acres) and operate more than 70% of the world's farmland. Nearly 40% of agricultural land is found on farms larger than 1,000 hectares (2,500 acres). However, five of every six farms in the world consist of fewer than 2 hectares (4.9 acres), and take up only around 12% of all agricultural land. Farms and farming greatly influence rural economics and greatly shape rural society, effecting both the direct agricultural workforce and broader businesses that support the farms and farming populations.

The major agricultural products can be broadly grouped into foods, fibers, fuels, and raw materials (such as rubber). Food classes include cereals (grains), vegetables, fruits, cooking oils, meat, milk, eggs, and fungi. Global agricultural production amounts to approximately 11 billion tonnes of food, 32 million tonnes of natural fibers and 4 billion m<sup>3</sup> of wood. However, around 14% of the world's food is lost from production before reaching the retail level. Modern agronomy, plant breeding, agrochemicals such as pesticides and fertilizers, and technological developments have sharply increased crop yields, but also contributed to ecological and environmental damage. Selective breeding and modern practices in animal husbandry have similarly

○ ○ ○ ○

# BASICS IN LIFE SCIENCE

Edited by  
DR. C. ANUSHIA



978-93-6255-640-0

**BASICS IN LIFESCIENCE**  
**Copyright © 2018 by Dr. C. ANUSHIA**

**All rights reserved. No part of this book may be reproduced or transmitted in any form or by any means without written permission from the author.**

**ISBN: 978-93-6255-640-0**

**Publisher: Ponnaiyah Ramajayam Institute of Science and Technology  
(PRIST)**

## TABLE OF CONTENT

<b>Chapter 1:</b> Critical Thinking Skills Development is Promoted by Active Learning in Flipped Life Science Courses <b>Dr. C. Anushia</b>	<b>01</b>
<b>Chapter 2:</b> Current advancements in the fundamental fibroblast growth factor's cell biology <b>Dr.P.Manonmani</b>	<b>12</b>
<b>Chapter 3:</b> Contributions and challenges for network models in cognitive neuroscience <b>Dr. Arjunpandian</b>	<b>25</b>
<b>Chapter 4:</b> In SDSS and ZCOSMOS, mass and environment as drivers of galaxy evolution and the origin of the schechter function <b>Dr. A. Shajahan</b>	<b>40</b>
<b>Chapter 5:</b> The strengthening the reporting of observational studies in epidemiology (STROBE) statement: guidelines for reporting observational studies <b>Dr. G. Venkatkumar</b>	<b>60</b>
<b>Chapter 6:</b> Gender differences in peer review outcomes and manuscript impact at six journals of ecology and evolution. <b>Dr. T. Veeramani</b>	<b>80</b>
<b>Chapter 7:</b> A Unified Empirical model based on the observed physical evolution of distant galaxies for infrared galaxy counts <b>Ms. J. Illamathi</b>	<b>105</b>

**Chapter:1**  
**CRITICAL THINKING SKILLS DEVELOPMENT IS PROMOTED BY ACTIVE  
LEARNING IN FLIPPED LIFE SCIENCE COURSES**

**Dr. C. Anushia**

*Associate professor, Department of Biotechnology  
PRIST Deemed to be University, Thanjavur*

**Introduction**

The improvement of critical thinking abilities has become a primary objective of undergraduate education throughout the last ten years. According to recent, widely reported studies, most undergraduates only slightly improve their analytical and critical thinking abilities while attending college (Arum and Roksa, 2011; Pascarella et al., 2011). It is still unclear what kinds of curriculum and pedagogical adjustments best assist undergraduates' development of critical thinking abilities, even though the outcomes from these studies may be debatable (Huber and Kuncel, 2016). (Niu et al., 2013; Huber and Kuncel, 2016). Numerous parties, such as companies (AAC&U, 2013; Korn, 2014), associations in higher education (Rhodes, 2008; Association of American Colleges and Universities [AAC&U], 2013), and governmental bodies (Duncan, 2010; National Academy of Sciences, National Academy of Engineering. Because there is no universally accepted definition of critical thinking, it is difficult to determine the best teaching practices to improve it. There are many other definitions and characteristics that have been proposed; the majority of them involve using reasoning and/or evidence to reach and assess conclusions. Critical thinking is, for instance, "the ability to draw reasonable conclusions based on evidence, logic, and intellectual honesty," according to Rowe and colleagues (Rowe et al., 2015). Ennis (2013) provides a definition of critical thinking as follows: "reasonable reflective thinking focused on deciding what to believe or do". He goes on to outline a number of critical thinking competencies, such as evaluating the reliability of sources, assessing the validity of arguments and inductive conclusions, and using previously established.

Prior to creating the Critical Thinking Assessment Test (CAT), Stein and colleagues discovered that professors concurred on a range of 12 critical thinking skills. Among them were the ability to distinguish between information that is factual and that is inferred, to recognize evidence that may confirm or refute a hypothesis, to distinguish between pertinent and unimportant data, and to analyze and combine data from many sources in order to solve an issue (Stein et al., 2007a). The importance of having a foundational understanding of mathematics is highlighted by the inclusion of basic mathematical reasoning and graphical information interpretation as critical thinking skills by both Ennis and Stein and colleagues (Stein et al., 2007a; Ennis, 2015). Science, technology, engineering, and mathematics (STEM) courses have come under heavy fire for not doing a good enough job of developing critical thinking skills, despite the fact that these abilities are well aligned with scientific methods (Handelsman et al., 2004). Undergraduate science education has been criticized for its reliance on traditional lecture rather than student-centered instructional methodologies and for its propensity to prioritize content over practice (Johnson and Pigliucci, 2004; Johnson, 2007; Alberts, 2005, 2009; Momsen et al., 2010). The American Association for the Advancement of Science [AAAS], 2009; Alberts, 2009; Aguirre et al., 2009). In response,

## **Chapter: 2**

### **CURRENT ADVANCEMENTS IN THE FUNDAMENTAL FIBROBLAST GROWTH FACTOR'S CELL BIOLOGY**

**Dr.P.Manonmani**

*Professor, Department of Biotechnology  
PRIST Deemed to be University, Thanjavur*

#### **Introduction**

Insulin was discovered in Toronto in 1921 by Fredrick Banting and Charles Best, with fortunate guidance and assistance from John Macleod. James Collip enabled its purification, following heroic efforts in Berlin, Strasbourg, Baltimore, and Bucharest. The voyage of this hormone throughout the body has not been as "romanticised" as its discovery tale, which is famous and earned it the Nobel Prize in Physiology or Medicine in 1923 (Karamitsos, 2011). As the primary anabolic hormone that promotes the deposition of dietary carbon sources, insulin's synthesis, quality control, distribution, and activity are all finely regulated in several organs or "stations" throughout its physiological journey. Highly coordinated intracellular systems carry out these tasks, beginning with synthesis in the  $\beta$ -cells of the On chromosome 11, the single insulin gene known as INS (two in rodents, *ins1* and *ins2*) is found in humans. Upstream enhancer elements bind important transcription factors, such as IDX1 (PDX1), MafA, and NeuroD1, in addition to a variety of coregulators, to regulate the transcription of the INS gene (Artner and Stein, 2008). These are necessary for insulin gene expression in the insulin-producing pancreatic  $\beta$ -cells and help control INS transcription in response to glucose and autocrine insulin signalling (Andrali et al., 2008). These enhancer elements, transcription factors, and their coregulators are essential defining contributors to the  $\beta$ -cell secretory pathway because of their role in regulating the expression of insulin and many other components, including glucose transporter 2 (GLUT2) and the insulin processing enzyme PC1/3.

A signal peptidase cleaves the signal sequence of insulin, converting it from preproinsulin (Fig. 2 A) during early translation to proinsulin in the RER. Proinsulin forms three disulphide bonds in the RER to connect the semihelical A domain and helical B domain, where it is folded and stabilised in its three-dimensional proinsulin shape. Following passage through the Golgi apparatus, the appropriately folded proinsulin is sorted into secretory granules that are still immature. There, it undergoes processing by the prohormone convertases PC1/3 and PC2, which cleave the C-peptide. Later, mature insulin is produced, which is composed of A- and B-peptide chains connected by disulphide bonds, after carboxypeptidase E eliminates the C-terminal basic amino acids from the resultant peptide chains (Hutton, 1994). Most insulin granules (perhaps 75–95% of an estimated 10,000) are stored within the  $\beta$ -cell cytoplasm at some distance away from the cell membrane (Rorsman and Renström, 2003). The remainder move to the cell periphery along microtubule networks in an AMPK- and kinesin1-dependent manner (McDonald et al., 2009). To reach the plasma membrane, however, granules must cross a cortical actin network that acts as a physical barrier to insulin secretion (Li et al., 1994). Actin reorganization is therefore an important component of the early journey of

**Chapter: 3**  
**CONTRIBUTIONS AND CHALLENGES FOR NETWORK MODELS IN**  
**COGNITIVE NEUROSCIENCE**

**Dr. Arjunpandian**

*Associate professor, Department of Biotechnology  
PRIST Deemed to be University, Thanjavur*

**Introduction**

The confluence of new approaches in recording patterns of brain connectivity and quantitative analytic tools from network science has opened new avenues toward understanding the organization and function of brain networks. Descriptive network models of brain structural and functional connectivity have made several important contributions; for example, in the mapping of putative network hubs and network communities. Building on the importance of anatomical and functional interactions, network models have provided insight into the basic structures and mechanisms that enable integrative neural processes. Network models have also been instrumental in understanding the role of structural brain networks in generating spatially and temporally organized brain activity. Despite these contributions, network models are subject to limitations in methodology and interpretation, and they face many challenges as brain connectivity data sets continue to increase in detail and complexity. The popularity of the study of language and the brain is evident from the large number of studies published since the early 1990s that have used PET, fMRI, EEG, MEG, TMS, or NIRS to investigate aspects of brain and language, in linguistic domains ranging from phonetics to discourse processing. The amount of resources devoted to such studies suggests that they are motivated by a viable and successful research program, and implies that substantive progress is being made. At the very least, the amount and vigor of such research implies that something significant is being learned. In this chapter, we present a critique of the dominant research program, and provide a cautionary perspective that challenges the belief that explanatorily significant progress is already being made. Our critique focuses on the question of whether current brain/language research provides an example of interdisciplinary cross-fertilization, or an example of cross-sterilization. In developing our critique, which is in part motivated by the necessity to examine the presuppositions of our own work (e.g., Embick, Marantz, Miyashita, O'Neil, & Sakai, 2000; Embick, Hackl, Schaeffer, Kelepir, & Marantz, 2001; Poeppel, 1996; Poeppel et al., 2004), we identify fundamental problems that must be addressed if progress is to be made in this area of inquiry.

We conclude with the outline of a research program that constitutes an attempt to overcome these problems, at the core of which lies the notion of computation. Systems neuroscience seeks explanations for how the brain implements a wide variety of perceptual, cognitive and motor tasks. Conversely, artificial intelligence attempts to design computational systems based on the tasks they will have to solve. In artificial neural networks, the three components specified by design are the objective functions, the learning rules and the architectures. With the growing success of deep learning, which utilizes brain-inspired architectures, these three designed components have increasingly become central to



## **Chapter:4**

### **IN SDSS AND ZCOSMOS, MASS AND ENVIRONMENT AS DRIVERS OF GALAXY EVOLUTION AND THE ORIGIN OF THE SCHECHTER FUNCTION**

***Dr. A. Shajahan***

*Assistant professor, Department of Biotechnology  
PRIST Deemed to be University, Thanjavur*

#### **Introduction**

Large samples of galaxies have been the subject of a deluge of new observational data in recent years: both locally, as in the case of the 2dfGRS (Colless et al. 2001) and the Sloan Digital Sky Survey (SDSS; York et al. 2000), and at higher redshifts, as in the case of large photometric and spectroscopic surveys, like COMBO-17 (Wolf et al. 2003), GOODS (Giavalisco et al. 2004), DEEP (Vogt et al. 2005; Weiner et al. 2005), DEEP2 (Davis et al. 2003), VVDS (Le Fèvre et al. 2005), and COSMOS and zCOSMOS (Scoville et al. 2007; Lilly et al. 2007). An increasingly complex statistical analysis of the general characteristics of the galaxy population and its history across cosmic time is made possible by these new surveys. A theory of galaxy evolution has also been developed extensively, mainly within the framework of so-called semi-analytic models (SAMs) for the galaxy population (see, for example, Baugh 2006 for a review). These models combine simple analytic descriptions of all imaginable relevant baryonic physics, such as the formation of stars, the heating and cooling of gas, and the merging of galaxies, with N-body simulations of the formation and evolution of dark matter haloes. Increasingly complex hydrodynamical simulations have been used to supplement SAMs (e.g., Birnboim & Dekel 2003).

This paper's approach to the evolving galaxy population is entirely empirical and based on observation. Specifically, it is believed that both the environment and the galactic mass are important factors in the evolution of galaxies. Thus, in the current galaxy population as well as the population at much older cosmic periods, we attempt to determine the most significant relationships between galaxy features and their stellar masses and surroundings. In order to develop scientifically based "laws" for the population's evolution, the objective is to use the observational material as directly as possible to discover the simplest things that appear to be demanded by the data. Through the process of locating and separating the major underlying patterns in various data sets, then merging.

After that, we might attempt to link these blatantly obvious evolutionary markers to a predominate physical process. However, this causal relationship cannot be established, and it is entirely likely that a different combination of physical processes will work together to produce the same observable outcomes. However, our discovery of the key empirical features of the history helps limit the possible results of the underlying physical processes and could shed light on the key parameters that appear to govern galaxy evolution. One could think of this method as a form of "purely empirical analytic model" for the evolution of galaxies. In this work, we mainly concentrate on the mechanisms that clearly lead to the termination of star formation in certain star-forming galaxies and the appearance of the

## Chapter:5

# THE STRENGTHENING THE REPORTING OF OBSERVATIONAL STUDIES IN EPIDEMIOLOGY (STROBE) STATEMENT: GUIDELINES FOR REPORTING OBSERVATIONAL STUDIES

**Dr. G. Venkatkumar**

*Assistant professor, Department of Biotechnology  
PRIST Deemed to be University, Thanjavur*

### **Introduction:**

Many questions in medical research are investigated in observational studies. Much of the research into the cause of diseases relies on cohort, case-control, or cross-sectional studies. Observational studies also have a role in research into the benefits and harms of medical interventions. Randomised trials cannot answer all important questions about a given intervention. For example, observational studies are more suitable to detect rare or late adverse effects of treatments, and are more likely to provide an indication of what is achieved in daily medical practice. Research should be reported transparently so that readers can follow what was planned, what was done, what was found, and what conclusions were drawn.

The credibility of research depends on a critical assessment by others of the strengths and weaknesses in study design, conduct, and analysis. Transparent reporting is also needed to judge whether and how results can be included in systematic reviews. However, in published observational research important information is often missing or unclear. An analysis of epidemiological studies published in general medical and specialist journals found that the rationale behind the choice of potential confounding variables was often not reported. Only a few reports of case-control studies in psychiatry explained the methods used to identify cases and controls. In a survey of longitudinal studies in stroke research, 17 of 49 articles (35%) did not specify the eligibility criteria. Others have argued that without sufficient clarity of reporting, the benefits of research might be achieved more slowly, and that there is a need for guidance in reporting observational studies.

Recommendations on the reporting of research can improve reporting quality. The Consolidated Standards of Reporting Trials (CONSORT) statement was developed in 1996 and revised 5 years later. Many medical journals supported this initiative, which has helped to improve the quality of reports of randomised trials. Similar initiatives have followed for other research areas—eg, for the reporting of meta-analyses of randomised trials or diagnostic studies. We established a network of methodologists, researchers, and journal editors to develop recommendations for the reporting of observational research: the Strengthening the Reporting of Observational Studies in Epidemiology (STROBE) statement

The Grades of Recommendation, Assessment, Development, and Evaluation (GRADE) Working Group is a group of health professionals, researchers, and guideline developers worldwide who, in 2000, began to work together to develop an optimal system of rating quality of evidence and determining strength of recommendations for clinical practice guidelines. The group now includes more than 200 members and continues, after a decade of work, to meet to refine and extend its methods. The group's more than 25 one- to two-day

## Chapter:6

# GENDER DIFFERENCES IN PEER REVIEW OUTCOMES AND MANUSCRIPT IMPACT AT SIX JOURNALS OF ECOLOGY AND EVOLUTION

**Dr. T. Veeramani**

*Research Associate, Department of Biotechnology  
Bharathidasan university, Trichy*

### Introduction:

Review of manuscripts by peers has been a key feature of scholarly publishing for nearly three centuries (Spier,2002). Peer review improves the quality of manuscripts before they are published (Bakanic, McPhail, & Simon, 1987; Goodman, Berlin, Fletcher, & Fletcher,1994 and helps editors identify contributions that will be the most impactful (Li & Agha, Paine & Fox,2018). However, peer review may also be subject to systemic biases that influence editorial outcomes (Lee, Sugimoto, Zhang, & Cronin,2013). For example, reviewers rate papers with famous authors, or authors from prestigious institutions, more highly (Tomkins, Zhang, & Heavlin,2017). Editors and reviewers may also exhibit biases, conscious, or unconscious, against authors who speak a different language or reside in a different country from themselves (Lee et al.,2013. Murray et al.,2018. However, gender bias, specifically bias against female authors, has garnered the most attention.

A wide diversity of research demonstrates that the productivity and performance of men is generally rated higher than that of women, even in controlled experiments (Moss-Racusin, Dovidio, Brescoll, Graham, & Handelsman,2012, and references therein). However, the frequency and degree to which peer review of scholarly manuscripts and grant proposals discriminates against women remains a subject of significant debate.

The studies testing for gender inequalities in peer review (even the meta-analyses aggregating these studies) are thus highly variable in results and conclusions. There are a variety of possible explanations for this variation. Studies vary in their research subjects; for example, peer reviewers for academic journals and granting agencies are generally professional scientists, whereas the manipulative studies that detect gender effects on assessment scores often use students as the evaluators, possibly contributing to the differences observed between correlative and manipulative studies. Also, gender differences may be obscured in correlational studies by other biases (such as prestige bias) and by the wide variation in quality and significance of the documents being assessed. It is notable that, although few correlational studies detect statistically significant effects of gender on peer review, effect sizes are usually in the hypothesized direction (bias against women). Regardless of the reason why there is so little consistency of conclusions among studies, it leaves unresolved questions about the frequency and magnitude of gender differences in the outcomes of scholarly peer review.

## Chapter:7

### A UNIFIED EMPIRICAL MODEL BASED ON THE OBSERVED PHYSICAL EVOLUTION OF DISTANT GALAXIES FOR INFRARED GALAXY COUNTS

***Ms. J. Ilamathi***

*Assistant professor, Department of Biotechnology  
PRIST Deemed to be University, Thanjavur*

#### **Introduction:**

Star formation rate (SFR) at a particular redshift exhibits a strong association with stellar mass ( $M_*$ ), and these galaxies make up the so-called SF main sequence (MS), which is made up of secularly evolving galaxies (e.g., Elbaz et al. 2007; Noeske et al. 2007; Daddi et al. 2007). At  $z < 2$ , this population represents around 85% of the universe's star formation rate density (SFRD) (Rodighiero et al. 2011; Sargent et al. 2012). Starbursts (SBs), or galaxies with extremely high specific star formation rates ( $sSFRs = SFR/M_*$ ), contribute the remaining portion of the star formation budget. These galaxies are most likely the result of recent mergers (e.g., Elbaz et al. 2011; Rodighiero et al. 2011). Sargent et al. (2012, S12 subsequently) demonstrated recently that it is possible to replicate infrared (IR) luminosity functions (LFs) by concurrently. While phenomenological or hybrid models (e.g., Béthermin et al. 2011; Gruppioni et al. 2011; Rahmati & van der Werf 2011; Lapi et al. 2011) perform better, they are primarily descriptive and use an evolution of the LF that is not driven by physical principles.

Purely semi-analytical models (e.g., Lacey et al. 2010; Somerville et al. 2012) have more difficulty reproducing infrared (IR) number counts. However, the new Herschel observations of counts per redshift slice (Berta et al. 2011; Béthermin et al. 2012b) exclude these recent models that passably recreate the overall counts at  $>3\sigma$ . This demonstrates the significance of redshift-dependent limitations in accurately modeling galaxy evolution and spurs the creation of new model generations.

We provide a novel infrared galaxy count model that expands upon the previously introduced 2-Star-Formation-Mode framework (2SFM) S12. Based on our current observational understanding of the evolution of MS and SB galaxies, this fiducial model makes sense. There is no need for extra fine tuning because all of the model's parameters are limited by outside data sets. We take a WMAP-7 cosmology and a Salpeter beginning mass function.

Our spectral energy distribution (SED) library is basic and is derived from Herschel data. It consists of two SEDs, one for the MS and one for the SB, which gets warmer as redshift increases. We can replicate recent Herschel data of galaxy counts, including counts per redshift slice, with our model. The strength of our 2-Star-Formation Modes (2SFM) decomposition in explaining the statistical characteristics of infrared sources and their evolution with cosmic time is demonstrated by this agreement. We talk about how different wavelengths and flux densities affect the number counts of MS and SB galaxies in relation to each other. Additionally, we demonstrate that a peak in the 1.4 GHz radio counts about 50  $\mu$ Jy is caused by MS galaxies. The model's content, which includes mock catalogs, SED

# STATISTICS AND NUMERICAL METHODS

Edited by

**S.MAHESWARAN**



978-93-6255-713-1

# **Statistics and Numerical Methods**

Copyright © 2018 by S.Maheswaran

First Edition,2018

*All rights reserved. No part of this book may be reproduced or transmitted in any form or by any means without written permission from the author.*

**ISBN: 978-93-6255-713-1**

***Publisher:*** Ponnaiyah Ramajayam Institute of Science and Technology (**PRIST**)

## TABLE OF CONTENTS

<b>Book elements</b>	<b>Page Numbers</b>
----- <b>Chapter-I</b> <b>ALGEBRAIC &amp; TRANSCENDENTAL EQUATION</b> Dr. K.Sangeetha	<b>01-15</b>
----- <b>Chapter-II</b> <b>NUMERICAL DIFFERENTIATION</b> Dr. K.Sangeetha	<b>16-24</b>
----- <b>Chapter-III</b> <b>NUMERICAL SOLUTION OF ODE</b> Dr. K.Sangeetha	<b>25-27</b>
----- <b>Chapter-IV</b> <b>BASIC STATISTICS</b> Dr. K.Sangeetha	<b>28-38</b>
----- <b>Chapter-V</b> <b>DISTRIBUTIONS</b> Dr. K.Sangeetha	<b>39-49</b>
-----	

# ALGEBRAIC & TRANSCENDENTAL EQUATIONS

**Dr. K.Sangeetha**

*Asst. Professor in Mathematics*

*Ponnaiyah Ramajayam Institute of Science and Technology (PRIST)*

*Vallam, Thanjavur, Tamilnadu, South India.*

Algebraic and transcendental equations are two fundamental types of equations in mathematics, distinguished by their properties and solutions.

### Algebraic Equations

Algebraic equations are equations involving variables, constants, and algebraic operations (addition, subtraction, multiplication, division, and root extraction). They can be expressed as:

$f(x) = 0$  where  $f(x)$  is a polynomial or a rational function.

Examples:

1. Linear equation:  $2x + 3 = 0$
2. Quadratic equation:  $x^2 + 4x + 4 = 0$
3. Cubic equation:  $x^3 - 2x^2 - 5x + 1 = 0$

Algebraic equations have:

- Finite degree (highest power of the variable)
- Solutions that can be expressed using radicals (e.g.,  $\sqrt{\quad}$ ,  $\sqrt[3]{\quad}$ )
- Solutions that are algebraic numbers (e.g., rational numbers, roots of unity)

### Transcendental Equations

Transcendental equations involve transcendental functions, such as exponential, logarithmic, trigonometric, or hyperbolic functions. These equations cannot be expressed as finite polynomials or rational functions.

Examples:

1. Exponential equation:  $e^x = 2$
2. Logarithmic equation:  $\log(x) = 3$
3. Trigonometric equation:  $\sin(x) = 1/2$

Transcendental equations have:



## NUMERICAL DIFFERENTIATION

**Dr. K.Sangeetha**

*Asst. Professor in Mathematics*

*Ponnaiyah Ramajayam Institute of Science and Technology (PRIST)*

*Vallam, Thanjavur, Tamilnadu, South India.*

Numerical differentiation is a method used to approximate the derivative of a function using numerical methods

**Analytical differentiation is difficult or impossible:** For complex functions or experimental data.

1. **Derivative not explicitly available:** In many engineering and scientific applications.
2. **Computational efficiency:** Numerical methods can be faster than analytical methods.

### Types of Numerical Differentiation

1. **Forward Difference:** Uses future values to approximate the derivative.
2. **Backward Difference:** Uses past values to approximate the derivative.
3. **Central Difference:** Uses both past and future values to approximate the derivative.

### Methods of Numerical Differentiation

1. **Finite Difference Methods:** Approximate derivatives using difference quotients.
2. **Gradient Methods:** Use multiple function evaluations to estimate the derivative.
3. **Richardson Extrapolation:** Combines finite difference estimates for improved accuracy.

The Trapezoidal Rule is a numerical integration method used to approximate the definite integral of a function.

### Trapezoidal Rule Formula:

$$\int [f(x) dx] \approx (h/2) * [f(x_0) + 2*\sum[f(x_i)] + f(x_n)]$$

where:

- $h = (b-a)/n$  is the width of each subinterval

## NUMERICAL SOLUTION OF ODE

**Dr. K.Sangeetha**

*Asst. Professor in Mathematics*

*Ponnaiyah Ramajayam Institute of Science and Technology (PRIST)*

*Vallam, Thanjavur, Tamilnadu, South India.*

### Taylor Series Expansion:

The Taylor Series Method is a numerical technique for solving Ordinary Differential Equations (ODEs) by approximating the solution using Taylor series expansions.

$$f(x + \Delta x) = f(x) + \Delta x * f'(x) + (\Delta x^2)/2! * f''(x) + (\Delta x^3)/3! * f'''(x) + \dots$$

### Taylor Series Method for ODEs:

$$y'(x) = f(x, y)$$

$$y(x + \Delta x) = y(x) + \Delta x * f(x, y) + (\Delta x^2)/2! * f'(x, y) + (\Delta x^3)/3! * f''(x, y) + \dots$$

### Computing Derivatives:

$$f'(x, y) = \partial f / \partial x + (\partial f / \partial y) * y'$$

$$f''(x, y) = \partial^2 f / \partial x^2 + 2(\partial^2 f / \partial x \partial y) * y' + (\partial^2 f / \partial y^2) * (y')^2 + \dots$$

### Example: Solve $y' = 2x - 3y$ , $y(0) = 1$

Using Taylor Series Method with  $\Delta x = 0.1$ :

$$\begin{aligned} y(0.1) &= y(0) + \Delta x * f(0, 1) + (\Delta x^2)/2! * f'(0, 1) \\ &= 1 + 0.1 * (-3) + (0.1^2)/2 * (-6) \\ &= 0.705 \end{aligned}$$

$$\begin{aligned} y'(0.1) &= 2(0.1) - 3(0.705) \\ &= -1.815 \end{aligned}$$

$$\begin{aligned} y(0.2) &= y(0.1) + \Delta x * f(0.1, 0.705) + (\Delta x^2)/2! * f'(0.1, 0.705) \\ &= 0.705 + 0.1 * (-1.815) + (0.1^2)/2 * (-5.545) \\ &= 0.4897 \end{aligned}$$

The Runge-Kutta 2nd order (RK2) method is a numerical technique for solving Ordinary Differential Equations (ODEs).

### RK2 Formula:

$$y_{n+1} = y_n + hf(y_n) + a_1 k_1$$

## BASIC STATISTICS

**Dr. K.Sangeetha***Asst. Professor in Mathematics**Ponnaiyah Ramajayam Institute of Science and Technology (PRIST)**Vallam, Thanjavur, Tamilnadu, South India.***Measures of Central Tendency:****Mean:** Average value of a dataset.Formula:  $(\Sigma x)/n$ Example: [2, 4, 6, 8, 10]  $\rightarrow$  Mean =  $(2+4+6+8+10)/5 = 6$ **Median:** Middle value of an ordered dataset.Formula:  $x_{((n+1)/2)}$  for odd n,  $(x_{(n/2)} + x_{(n/2 + 1)})/2$  for even nExample: [2, 4, 6, 8, 10]  $\rightarrow$  Median = 6**Mode:** Most frequently occurring value.Example: [2, 4, 4, 6, 4]  $\rightarrow$  Mode = 4**Problem:**

Find the mean of the following dataset:

12, 18, 20, 22, 25, 30, 36, 40, 45, 50

**Solution:****Step 1: List the numbers**

12, 18, 20, 22, 25, 30, 36, 40, 45, 50

**Step 2: Add up the numbers** $12 + 18 = 30$  $30 + 20 = 50$

## DISTRIBUTIONS

**Dr. K.Sangeetha**

*Asst. Professor in Mathematics  
Ponniyiah Ramajayam Institute of Science and Technology (PRIST)  
Vallam, Thanjavur, Tamilnadu, South India.*

A distribution describes the probability of different values or intervals of values that a random variable can take.

### **Discrete Distributions:**

### **Bernoulli Distribution:**

#### **Definition:**

The Bernoulli distribution is a discrete probability distribution that models a single trial with two possible outcomes:

1. Success (S)
2. Failure (F)

#### **Parameters:**

1.  $p$ : Probability of success ( $0 \leq p \leq 1$ )
2.  $q$ : Probability of failure ( $q = 1 - p$ )

#### **Probability Mass Function (PMF):**

$$P(X = k) = p^k * q^{(1-k)}$$

where:

- $X$ : Random variable
- $k$ : Outcome (0 or 1)
- $p$ : Probability of success
- $q$ : Probability of failure

#### **Problem 1:**

A coin is tossed. Find the probability of getting heads.



# MATRICES AND CALCULUS

Edited by  
**S.MAHESWARAN**



978-93-6255-149-8

# **MATRICES AND CALCULUS**

Copyright © 2018 by S.Maheswaran

First Edition,2018

*All rights reserved. No part of this book may be reproduced or transmitted in any form or by any means without written permission from the author.*

**ISBN: 978-93-6255-149-8**

***Publisher:*** Ponnaiyah Ramajayam Institute of Science and Technology (**PRIST**)

## TABLE OF CONTENTS

<b>Book elements</b>	<b>Page Numbers</b>
----- <b>Chapter-I</b> <b>MATRICES</b> Dr. P.Padma	<b>01-08</b>
----- <b>Chapter-II</b> <b>DIFFERENTIAL CALCULUS</b> Dr. P.Padma	<b>09-16</b>
----- <b>Chapter-III</b> <b>FUNCTIONS OF SEVERAL VARIABLES</b> Dr. P.Padma	<b>17-28</b>
----- <b>Chapter-IV</b> <b>INTEGRAL CALCULUS</b> Dr. P.Padma	<b>29-35</b>
----- <b>Chapter-V</b> <b>MULTIPLE INTEGRALS</b> Dr. P.Padma	<b>36-46</b>
-----	

## MATRICES

**Dr.P.PADMA**

*Asst. Professor in Mathematics*

*Ponnaiyah Ramajayam Institute of Science and Technology (PRIST)*

*Vallam, Thanjavur, Tamilnadu, South India.*

### INTRODUCTION

The concept of matrices and their basic operations were introduced by the British mathematician Arthur Cayley in the year 1858. He wondered whether this part of mathematics will ever be used. However, after 67 years, in 1925, the German physicist Heisenberg used the algebra of matrices in his revolutionary theory of quantum mechanics. Over the years, matrices have been found as an elegant and powerful tool in almost all branches of Science and Engineering like electrical networks, graph theory, optimisation techniques, system of differential equations, stochastic processes, computer graphics, etc. Because of the digital computers, usage of matrix methods have become greatly fruitful.

Here we study certain numbers associated with a square matrix, called eigen values and certain vectors associated with them, called eigen vectors. These are useful in the study of canonical forms of a matrix such as diagonalisation and in the study of quadratic forms. The problem of determining eigen values and eigen vectors of a square matrix is called an **eigen value problem**.

### EIGEN VALUES AND EIGEN VECTORS

**Definition 1.1** Let  $A$  be a square matrix of order  $n$ . A number  $\lambda$  is called an eigen value of  $A$  if there exists a non-zero column matrix  $X$  such that  $AX = \lambda X$ . Then  $X$  is called an eigen vector of  $A$  corresponding to  $\lambda$ .

$$\text{If } A = [a_{ij}]_{n \times n} \text{ and } X = \begin{bmatrix} x_1 \\ x_2 \\ \vdots \\ x_n \end{bmatrix}, \text{ then}$$

$AX = \lambda X \Rightarrow (A - \lambda I)X = 0$ . This will represent a system of linear homogeneous equations in  $x_1, x_2, \dots, x_n$ . Since  $X \neq 0$  at least one of the  $x_i \neq 0$ . Hence the homogeneous system has nontrivial solutions.

$\therefore$  the determinant of coefficients  $|A - \lambda I| = 0$ . This equation is called the **characteristic equation** of  $A$ . The determinant  $|A - \lambda I|$ , on expansion, will be a  $n^{\text{th}}$  degree polynomial in  $\lambda$  and



# DIFFERENTIAL CALCULUS

**Dr.P.PADMA**

*Asst. Professor in Mathematics*

*Ponnaiyah Ramajayam Institute of Science and Technology (PRIST)*

*Vallam, Thanjavur, Tamilnadu, South India.*

## INTRODUCTION

Calculus is one of the remarkable achievements of the human intellect. It is a collection of fascinating and exciting ideas rather than a technical tool. Calculus has two main divisions namely differential calculus and integral calculus. They serve to solve a variety of problems that arise in science, engineering and other fields including social sciences.

Differential calculus had its origin from the problem of finding tangent to a curve and integral calculus had its origin from the problem of finding plane area. The concept of derivative which measure the rate of change of a function is the central idea in differential calculus.

## FUNCTION

Calculus begins with the study of functions. Functions are very fundamental in mathematics. The term function was coined by Leibnitz in 1673. A function is a tool that scientists and mathematicians use to describe relationship between varying quantities

For example:

1. The speed of a rocket is a function of its payload.
2. The price of a ticket is a function of where you sit.
- . The perimeter of a circle is a function of its radius.

We now formally define a function.

### Definition 2.1 Function

A **function**  $f$  from a set  $A$  to a set  $B$  is a rule that assigns to each element  $x \in A$  a unique element  $y$  in  $B$ .

The element  $y$  in  $B$  is called the image of  $x$  under for the value of  $f$  at  $x$  and is written symbolically as  $f(x)$ .

Thus, we have  $y = f(x)$ .

**FUNCTIONS OF SEVERAL VARIABLES**

**Dr.P.PADMA**

*Asst. Professor in Mathematics*

*Ponnaiyah Ramajayam Institute of Science and Technology (PRIST)*

*Vallam, Thanjavur, Tamilnadu, South India.*

**INTRODUCTION**

There are many practical situations in which a quantity of interest depends on the values of two or more variables.

For example

(i) the volume of a cylinder is  $V = \pi r^2 h$ , where  $r$  is the radius of the base circle and  $h$  is the height of the cylinder. So,  $V$  is a function of two variables.

(ii) The volume of a rectangular parallelopiped is  $V = lbh$ , where  $l, b, h$  are the length, breadth and height. Here  $V$  is a function of three variables.

Similarly we can have functions of more than two or three variables. But, simplicity, we shall deal with functions of two variables and the arguments and results can be extended for more than two variables.

**LIMIT AND CONTINUITY**

**Definition 3.1.1 Function of two variables** Let  $S$  be subset of  $R^2$ . A function  $f: S \rightarrow R$  is a rule which assigns to every  $(x, y) \in S$  a unique real number in  $R$ , denoted by  $f(x, y)$ .

We say  $f(x, y)$  is a function of two independent variables  $x$  and  $y$ .

$S$  is called the domain of the function  $f$ .

$$\frac{x^2 + 3x}{x - y},$$

**Example 1** If  $f(x, y) = \frac{x^2 + 3x}{x - y}$ , find the domain and  $f(1, 3)$ .

**Solution**

Domain of  $f$  is the set of all points in the plane at which  $f(x, y)$  exists.  $f(x, y)$  is defined for all  $x \neq y$

## INTEGRAL CALCULUS

**Dr.P.PADMA**

*Asst. Professor in Mathematics*

*Ponnaiyah Ramajayam Institute of Science and Technology (PRIST)*

*Vallam, Thanjavur, Tamilnadu, South India.*

### INTRODUCTION

We have seen in chapter 1, that the problem of finding a tangent line at a point on a curve led to the concept of a derivative as a limit of difference quotient. The derivative is the central idea in differential calculus.

Now, we shall see how the problem of finding the area under a curve will lead to the concept of definite integral as a limit of a sum. The definite integral is the central idea in integral calculus.

### DEFINITE INTEGRAL

#### (RECTANGLE METHOD OF FINDING AREA)

Let  $f$  be a continuous function on the closed interval  $[a, b]$ , except possibly at a finite number of points, and bounded everywhere in  $[a, b]$ . If  $[a, b]$  is divided into  $n$  equal parts, each of length

$$\Delta x = \frac{b-a}{n},$$

using the points of division.

$$a = x_0, x_1, x_2, \dots, x_{n-1}, x_n = b.$$

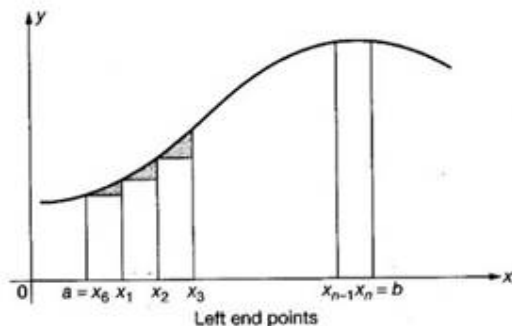

**MULTIPLE INTEGRALS**

**Dr.P.PADMA**

*Asst. Professor in Mathematics*

*Ponnaiyah Ramajayam Institute of Science and Technology (PRIST)*

*Vallam, Thanjavur, Tamilnadu, South India*

**DOUBLE INTEGRATION**

Double integrals occur in many practical problems in science and engineering. It is used in problems involving area, volume, mass, centre of mass. In probability theory it is used to evaluate probabilities of two dimensional continuous random variables.

**1. Double integrals in cartesian coordinates**

A double integral is defined as the limit of a sum. Let  $f(x, y)$  be a continuous function of two independent variables  $x$  and  $y$  defined in a simple closed region  $R$ . Sub-divide  $R$  into element areas  $\Delta A_1, \Delta A_2, \dots, \Delta A_n$  by drawing lines parallel to the coordinate axes.

Let  $(x_1, y_1)$  be any point in  $\Delta A_1$ . Find the sum.

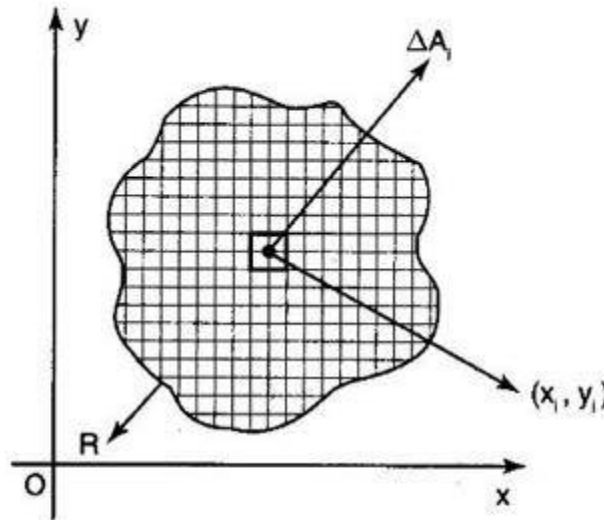

**Fig. 5.1**

$$f(x_1, y_1)\Delta A_1 + f(x_2, y_2)\Delta A_2 + \dots + f(x_n, y_n)\Delta A_n$$

$$= \sum_{i=1}^n f(x_i, y_i) \Delta A_i$$



# ENGINEERING PHYSICS I

*Edited by*

**K.SWAMINATHAN**



978-93-6255-984-3

Engineering Physics I  
Copyright © 2018 by *Mr. K. Swaminathan*

All rights reserved. No part of this book may be reproduced or transmitted in any form or by any means without written permission from the author.

ISBN: 978-93-6255-904-3

Publisher: Ponnaiyah Ramajayam Institute of Science and Technology (PRIST)

## TABLE OF CONTENTS

Introduction.....	19
CHAPTER 1 Mechanical Properties of Solids.....	20
<i>Mr. K. Swaminathan</i>	
CHAPTER 2 Ultrasonics .....	31
<i>Dr. L. Chinnappa</i>	
CHAPTER 3 Electrostatics .....	42
<i>Dr. M. Sivanantham</i>	
CHAPTER 4 Magnetostatics .....	52
<i>Dr. M. Silambarasan</i>	
CHAPTER 5 Electromagnetic Waves.....	69
<i>Dr. V. Vidhya</i>	
CHAPTER 6 Non-Destructive Testing .....	88
<i>Dr. K. Thirunavukarasu</i>	
CHAPTER 7 Crystal Structure.....	105
<i>Dr. Sutapa Ghosh</i>	
REFERENCES.....	125

**CHAPTER 1**  
**Mechanical Properties of Solids**  
**Mr. K. Swaminathan**

*Department of Physics, PRIST Deemed to be University,  
Thanjavur-613403, Tamilnadu, India*

**Introduction**

The mechanical properties of solids describe how materials respond to external forces, revealing their strength, elasticity, plasticity, toughness, and other characteristics that determine their suitability for various applications. Understanding these properties is crucial for selecting and designing materials in engineering, construction, manufacturing, and numerous other fields. These properties are influenced by the atomic structure, bonding, and microstructure of materials, and are critical for predicting their behavior under different conditions such as load, temperature, and deformation.

The mechanical properties of solids are fundamental to the study and application of materials in engineering and technology. They provide insights into how materials behave under different types of forces and conditions, enabling the development of safer, more durable, and efficient products and structures. A thorough understanding of these properties is essential for innovation and advancement in fields ranging from construction and manufacturing to aerospace and electronics.

**Key Mechanical Properties of Solids**

**Elasticity:**

Elasticity refers to a material's ability to return to its original shape after the removal of an applied force. It is governed by Hooke's Law, which states that stress is proportional to strain within the elastic limit of the material. The key parameter is the Young's Modulus, which quantifies the stiffness of a material. Materials with high elasticity, such as steel, can withstand large stresses without permanent deformation.



## **CHAPTER 2**

### **Ultrasonics**

#### **Dr. L. Chinnappa**

*Department of Physics, PRIST Deemed to be University,  
Thanjavur-613403, Tamilnadu, India*

### **Introduction**

Ultrasonics is the branch of science and technology that deals with the generation, transmission, and detection of sound waves at frequencies above the upper limit of human hearing, typically above 20 kHz. These high-frequency sound waves have a wide range of applications across various fields due to their unique properties, such as the ability to propagate through different media, high energy concentration, and non-invasive interaction with materials and biological tissues.

Ultrasonics is a powerful and versatile technology with a wide array of applications across science, medicine, industry, and engineering. Its ability to provide high-resolution imaging, precise measurements, and non-invasive testing makes it indispensable in modern technology and research. As advancements in ultrasonic technology continue, it promises to play an even more significant role in various fields, driving innovation and improving quality of life.

### **Basic Principles of Ultrasonics**

Ultrasonic waves, like other sound waves, are mechanical vibrations that propagate through a medium (solid, liquid, or gas) via particle oscillations. However, due to their high frequencies, they exhibit distinct characteristics:

#### **Frequency and Wavelength:**

Ultrasonic waves have shorter wavelengths compared to audible sound waves, allowing them to interact with smaller objects and features, making them useful for high-resolution imaging and precise measurements.

#### **Modes of Propagation:**

Ultrasonic waves can propagate in different modes depending on the medium and application. Common modes include longitudinal waves, where particle motion is parallel to

**CHAPTER 3**  
**Electrostatics**  
**Dr. M. Sivanantham**

*Department of Physics, PRIST Deemed to be University,  
Thanjavur-613403, Tamilnadu, India*

**Introduction**

Electrostatics is the branch of physics that deals with the study of electric charges at rest. It encompasses the forces, fields, and potentials associated with stationary charges and their interactions. The fundamental principles of electrostatics are essential for understanding a wide range of natural phenomena and technological applications, from the behavior of lightning and the attraction of dust particles to designing capacitors and other electronic components.

Electrostatics is a cornerstone of classical physics that explains the behavior and interaction of stationary electric charges. Its principles are foundational to many technological applications and natural processes, making it a critical area of study in both theoretical and applied physics. Understanding electrostatics provides insights into the forces and fields that govern the behavior of charges and enables the development of a wide range of technologies that are integral to modern life.

Fundamental Concepts in Electrostatics

Electric Charge:

Nature of Charge:

Electric charge is a fundamental property of matter, manifesting in two types: positive and negative. Like charges repel each other, while opposite charges attract. The basic unit of charge is carried by the electron (negative) and the proton (positive).

Quantization of Charge:

Charge is quantized, meaning it occurs in discrete amounts. The elementary charge, denoted by 'e', is approximately  $1.602 \times 10^{-19}$  coulombs.

**CHAPTER 4**  
**Magnetostatics**  
**Dr. M. Silambarasan**

*Department of Physics, PRIST Deemed to be University,  
Thanjavur-613403, Tamilnadu, India*

**Introduction**

Magnetostatics is the branch of physics that deals with the study of magnetic fields in systems where the currents are steady (not changing with time). It is the magnetic analogue of electrostatics, focusing on magnetic fields produced by constant electric currents and the forces and interactions of these fields with materials. Magnetostatics provides the foundational principles for understanding permanent magnets, magnetic materials, and the behavior of magnetic fields around current-carrying conductors, making it essential for various applications in science and engineering.

Magnetostatics provides a comprehensive framework for understanding magnetic fields and their interactions with materials and currents. It plays a crucial role in the development of technologies that utilize magnetic fields, such as electromagnets, motors, sensors, and data storage systems. A solid grasp of magnetostatics principles is essential for advancing both theoretical studies and practical applications in physics, engineering, and technology.

Fundamental Concepts in Magnetostatics

Magnetic Field (B):

The magnetic field is a vector field that describes the magnetic influence of electric currents and magnetic materials. It is represented by the symbol  $B$  and measured in units of tesla (T) or gauss (G). A magnetic field exerts a force on moving charges and other magnetic fields, influencing the motion and alignment of magnetic dipoles.

Biot-Savart Law:

The Biot-Savart Law describes the magnetic field generated by a small segment of current-carrying conductor. It is analogous to Coulomb's law in electrostatics and is given by:

# CHAPTER 5

## Electromagnetic Waves

### Dr. V. Vidhya

*Department of Physics, PRIST Deemed to be University,  
Thanjavur-613403, Tamilnadu, India*

### Introduction

Electromagnetic waves are a form of energy that propagates through space as oscillating electric and magnetic fields. These waves are fundamental to many aspects of modern life, from the light we see to the radio waves we use for communication. They do not require a medium to travel and can move through a vacuum, making them unique compared to mechanical waves such as sound. Understanding electromagnetic waves is essential for fields like physics, engineering, and communication technology.

Electromagnetic waves are a fundamental aspect of the universe, playing a critical role in both natural phenomena and human technology. Their diverse applications, from communication to medical diagnostics, make them indispensable in modern society. A deep understanding of electromagnetic waves and their properties is essential for advancing technology and science, opening new possibilities in fields ranging from communication to healthcare and beyond.

### Basic Principles of Electromagnetic Waves

#### Nature of Electromagnetic Waves:

Electromagnetic waves are generated by the acceleration of electric charges, which creates oscillating electric (E) and magnetic (B) fields that are perpendicular to each other and to the direction of wave propagation. They are transverse waves, meaning the oscillations of the fields are perpendicular to the direction of the wave's travel.

#### Wave Equation and Speed:

The wave equation for electromagnetic waves is derived from Maxwell's equations, which describe the behavior of electric and magnetic fields. The speed of these waves in a vacuum is given by:  $c = 1/\mu_0\epsilon_0 \approx 3 \times 10^8$  m/s.

**CHAPTER 6**  
**Non-Destructive Testing**  
**Dr. K. Thirunavukarasu**

*Department of Physics, PRIST Deemed to be University,  
Thanjavur-613403, Tamilnadu, India*

**Introduction**

Non-Destructive Testing (NDT) refers to a range of techniques and methods used to evaluate the properties and integrity of materials, components, or structures without causing damage or permanently altering them. NDT is widely used across various industries, including aerospace, automotive, construction, and manufacturing, to ensure the safety, reliability, and quality of products and systems. It plays a crucial role in detecting defects, preventing failures, and maintaining high standards in production and maintenance processes.

NDT is an essential aspect of modern engineering and quality assurance, enabling the detection of defects and ensuring the safety, reliability, and longevity of materials and structures without causing damage. With a variety of techniques available, NDT plays a crucial role in industries ranging from aerospace to construction, safeguarding both people and assets through rigorous, non-invasive testing methods.

Fundamental Principles of NDT

Purpose and Importance:

The primary goal of NDT is to identify defects such as cracks, voids, inclusions, and other imperfections that could compromise the functionality or safety of a material or structure. By assessing the internal and surface conditions without destruction, NDT helps in maintaining the structural integrity and extending the lifespan of components while minimizing costs associated with repair and downtime.

Basic Types of Defects:

Surface Defects:

Include cracks, corrosion, and other imperfections visible on the surface.

**CHAPTER 7**  
**Crystal Structure**  
**Dr. Sutapa Ghosh**

*Department of Physics, PRIST Deemed to be University,  
Thanjavur-613403, Tamilnadu, India*

**Introduction**

Crystal structure refers to the orderly, repeating arrangement of atoms, ions, or molecules in a crystalline solid. This structured arrangement forms a three-dimensional pattern, which extends throughout the material and is a fundamental characteristic that determines many of the physical properties of solids, such as strength, electrical conductivity, and optical behavior. Understanding crystal structure is essential in fields such as materials science, chemistry, physics, and engineering, as it provides insights into how materials behave and how they can be manipulated for various applications.

Crystal structure is a fundamental aspect of material science, influencing the physical, chemical, and mechanical properties of solids. By understanding and manipulating crystal structures, scientists and engineers can develop advanced materials for a wide range of applications, from everyday products to high-tech devices and cutting-edge technologies.

**Fundamental Concepts of Crystal Structure**

**Crystalline Solids:**

Crystalline solids are materials whose atoms are arranged in a highly ordered, repeating pattern that extends in all three spatial dimensions. Common examples include metals, salts, and minerals. This regular arrangement distinguishes them from amorphous solids, such as glass, where the atoms are not ordered.

**Unit Cell:**

The unit cell is the smallest repeating unit of a crystal lattice that, when repeated in space, forms the entire crystal. It defines the symmetry and dimensions of the crystal structure and is characterized by its lattice parameters: edge lengths ( $a$ ,  $b$ ,  $c$ ) and angles ( $\alpha$ ,  $\beta$ ,  $\gamma$ ). The geometry of the unit cell determines



# ENGINEERING MATERIALS AND METALLURGY

Edited By  
**DR S V SRIDHAR**



978-93-6255-257-0

Engineering Materials And Metallurgy

Copyright © 2018-2019 by Dr. S V Sridhar

All rights reserved. No part of this book may be reproduced or transmitted in any form or by any means without written permission from the author.

ISBN: 978-93-6255-257-0

Publisher: PRIST Publications.



**TABLE OF CONTENTS**

Introduction .....	11
CHAPTER 1 Constitution of Alloys and Phase Diagrams .....	23

**G ARUNKUMAR**

CHAPTER 2 – Iron carbide equilibrium diagram Heat Treatment of steel .....	45
---	----

**P SARATH KUMAR**

CHAPTER 3 Ferrous and Non-Ferrous Metals.....	69
---	----

**J RAJESH**

CHAPTER 4 Non-Metallic Materials in Engineering .....	96
---	----

**D.BALAJI**

CHAPTER 5 Mechanical Properties and Deformation Mechanisms .....	140
---	-----

**Dr V YALINI**

CHAPTER 6 Annealing .....	191
---------------------------	-----

**DR.S.DHANUSKODI**

CHAPTER 7 Polymers .....	259
K PURUSHOTHAMAN	
CHAPTER 8 Engineering Ceramics .....	363
M SUDHAKAR	
CHAPTER 9 Composites .....	409
N.SIVAHARINATHAN	
CHAPTER 10 Mechanisms of plastic deformation, slip and twinning .....	496
G BRITHIVIRAJ	
REFERENCES.....	580

## **CHAPTER 1 CONSTITUTION OF ALLOYS AND PHASE DIAGRAM**

**MR. G ARUNKUMAR**

*Assistant Professor, Department of Mechanical  
Engineering, Ponnaiyah Ramajayam Institute Of  
Science And Technology, Tamil Nadu, India.*

This chapter aims to familiarize students with the advanced concept of alloys and this chapter introduces the Constitution of Alloys and Phase Diagram.

An alloy consists of two or more elements, either as a compound or a solution. The components of alloys are generally metals. Here's an overview of each platform:

Constitution of Alloys and Phase Diagram include:

The state variables (temperature and composition) define a point on the phase diagram: the constitution point. The first thing to establish at a constitution point is the number of phases present, one or two (in a binary system).

Key features of Constitution of Alloys and Phase Diagram:

Phase diagrams, are graphical representations that show the relationship between the phases present in an alloy system under specific conditions.

## **CHAPTER 1 IRON CARBIDE EQUILIBRIUM DIAGRAM**

**MR. P SARATH KUMAR**

*Assistant Professor, Department of Mechanical  
Engineering, Ponnaiyah Ramajayam Institute of Science And  
Technology, Tamil Nadu, India.*

This chapter aims to familiarize students with the advanced concept of Iron carbide equilibrium Diagram.

For an iron-carbon phase diagram, the temperature is plotted on the Y axis and carbon content, as a percentage of the weight, is plotted on the X axis. The graph is split up into segments, and each segment represents a different phase of the microstructure. Here's an overview of each platform.

Iron carbide equilibrium Diagram includes:

The part of iron-carbon alloy system diagram between pure iron and an interstitial compound, iron carbide ( $\text{Fe}_3\text{C}$ ), containing 6.67 percent carbon by weight is called iron-iron carbide equilibrium diagram.

Key features of Iron carbide equilibrium Diagram:

- $\alpha$ -ferrite - solid solution of C in BCC Fe.
- Stable form of iron at room temperature. The maximum solubility of C is 0.022 wt%.
- $\gamma$ -austenite - solid solution of C in FCC Fe.

## **CHAPTER 3 HEAT TREATMENT OF STEEL**

**MR. J RAJESH**

*Assistant Professor, Department of Mechanical Engineering, Ponnaiyah Ramajayam Institute of Science And Technology, Tamil Nadu, India.*

This chapter aims to familiarize students with the advanced concept of Heat Treatment of steel and this chapter introduces the Heat Treatment of steel .

Heat treating changes metal properties by heating the metal to a specific temperature, holding it at that temperature for a certain length of time, and then using one of several methods to control the cooling of the metal. Here's an overview of each platform.

Heat Treatment of steel includes:

Common types of heat treating methods include annealing, hardening, quenching, and stress relieving, each of which has its own unique process

Key features of Heat Treatment of steel:

Steel is heated to a temperature higher than its transformation point to form austenite; then the steel is quickly cooled to form martensite. This process increases the hardness and strength of the steel without changing its shape, but the steel becomes more brittle.

## **CHAPTER 4 NON-METALLIC MATERIALS IN ENGINEERING**

**MR. D.BALAJI**

*Assistant Professor, Department of Mechanical  
Engineering, Ponnaiyah Ramajayam Institute of Science And  
Technology, Tamil Nadu, India.*

This chapter aims to familiarize students with the advanced concept of s the Non-Metallic Materials in Engineering.

Non-metallic materials are any materials, both synthetic and natural, which do not contain metal. These materials are able to retain their unique chemical properties during the machining process. Here's an overview of each platform.

Non-Metallic Materials in Engineering includes:

As one of the more affordable and versatile non - metallic's, plastics are a desirable choice for a wide range of projects. Typically, these materials are composed of plasticizers, pigments, and fillers joined together by a natural or synthetic binding agent.

Key features of Non-Metallic Materials in Engineering:

Non-metallic materials offer a range of physical and chemical properties, including having low thermal and electrical conductivity, making them good insulators as well as offering a high resistance to chemicals and corrosion.

## **CHAPTER 5 MECHANICAL PROPERTIES AND DEFORMATION MECHANISMS**

**Dr V YALINI**

*Assistant Professor, Department of Mechanical  
Engineering, Ponnaiyah Ramajayam Institute of Science and  
Technology, Tamil Nadu, India.*

This chapter aims to familiarize students with the Advanced concept of the Mechanical Properties Deformation Mechanisms.

The mechanical behavior of materials is determined by a combination of reversible and irreversible deformation mechanisms. The relative amount of each determines the material's deformation behavior. Here's an overview of each platform.

Mechanical Properties Deformation Mechanisms includes:

There are two main groups of such mechanisms; recovery, which removes dislocations inside the crystal lattice, and recrystallisation that operates by migration of grain boundaries.

Key features of Mechanical Properties Deformation Mechanisms:

Deformation mechanisms are the ways in which plastic strain occurs in materials, and they play a key role in shaping materials during deformation.

## CHAPTER 6 ANNEALING

**Dr V YALINI**

*Associate Professor, Department of Mechanical Engineering, Ponnaiyah Ramajayam Institute of Science and Technology, Tamil Nadu, India.*

This chapter aims to familiarize students with the Advanced concept of the Annealing and this chapter introduces various annealing process.

Annealing is commonly used on steels, cast iron, and alloys. There are many different types of annealing processes, including full annealing and process annealing. Here's an overview of each platform.

Annealing includes:

It involves heating a material above its recrystallization temperature, maintaining a suitable temperature for an appropriate amount of time and then cooling.

Key features of Annealing:

- **Recrystallization:** Annealing involves recrystallization, which is the process of creating new stress-free crystals in a matrix that is also stress free.
- **Quality control:** Annealing helps to ensure the predictability of material properties, which is important for quality control in manufacturing.
- **Material properties:** Annealing can be tailored to achieve specific material properties.



## **CHAPTER 7 POLYMERS**

**K PURUSHOTHAMAN**

*Assistant Professor, Department of Mechanical Engineering, Ponnaiyah Ramajayam Institute of Science and Technology, Tamil Nadu, India.*

This chapter aims to familiarize students with the Advanced concept of the Polymers and this chapter introduces various Polymers process.

Polymers are a wide range of materials used in engineering that are commonly known as plastics, rubbers, and adhesives. They are used in many applications and are categorized into 20 different families with over 15,000 types available commercially. Here's an overview of each platform.

Polymers include:

Polymers make up many of the materials in living organisms, including for example, proteins, cellulose, and nucleic acids. Moreover, they constitute the basis of such minerals as diamond, quartz, and feldspar and such man-made materials as concrete, glass, paper, plastics, and rubbers.

Key features of Polymers:

- **High molecular weight:** Polymers have high molecular weights, which contribute to their high mechanical strength and hardness.
- **Tensile strength:** Tensile strength is an important property for polymers because they are often used in construction and manufacturing, where products need to withstand a lot of stress.

## CHAPTER 8 ENGINEERING CERAMICS

**K PURUSHOTHAMAN**

*Assistant Professor, Department of Mechanical Engineering, Ponnaiyah Ramajayam Institute of Science and Technology, Tamil Nadu, India.*

This chapter aims to familiarize students with the Advanced concept of the Engineering Ceramics and this chapter introduces various Engineering Ceramics process.

Engineering ceramics can be divided into two categories according to their characteristics and uses: structural ceramics and functional ceramics. Structural ceramics refers to ceramics that can be used as engineering structural materials. Here's an overview of each platform.

Engineering Ceramics include:

There are five general types of ceramics, including structural, refractory, electrical, magnetic, and abrasive. Each type has different characteristics and functions. Structural ceramics have strong chemical bonding that can endure stress, heat, and corrosion.

Key features of Engineering Ceramics:

- High strength, hardness, and elastic modulus: Engineering ceramics are known for their high strength, hardness, and elastic modulus.
- High temperature resistance: Engineering ceramics can withstand high temperatures.
- Wear resistance: Engineering ceramics are resistant to wear.
- Thermal shock resistance: Engineering ceramics can withstand thermal shock.

## CHAPTER 9 Composites

**N.SIVAHARINATHAN**

*Assistant Professor, Department of Mechanical Engineering, Ponnaiyah Ramajayam Institute of Science and Technology, Tamil Nadu, India.*

This chapter aims to familiarize students with the Advanced concept of the Composites and this chapter introduces various Composites process.

A composite is a material made from two or more different materials that are combined to create a new material with different properties than the original materials. Here's an overview of each platform.

Composites include:

Typical engineered composite materials include: Reinforced concrete and masonry. Composite wood such as plywood. Reinforced plastics, such as fibre-reinforced polymer or fiberglass.

Key features of Composites:

- **Strength and stiffness:** Composite materials have high strength and stiffness in a wide temperature range.
- **Low density:** Composite materials are lightweight and have low density.
- **Resistance to corrosion:** Composite materials are highly resistant to corrosion and oxidation

## **CHAPTER 10 MECHANISMS OF PLASTIC DEFORMATION, SLIP AND TWINNING**

**G BRITHIVIRAJ**

*Assistant Professor, Department of Mechanical  
Engineering, Ponnaiyah Ramajayam Institute of Science and  
Technology, Tamil Nadu, India.*

This chapter aims to familiarize students with the Advanced concept of the Mechanisms of plastic deformation, slip and twinning and this chapter introduces various Mechanisms of plastic deformation, slip and twinning process.

The sliding of crystal blocks over one another along crystallographic planes, or slip planes. This is similar to pushing cards in a deck. Slip is the primary mechanism of deformation in metals and occurs when shear stress exceeds a critical value. Twinning occurs when slip is not possible. Here's an overview of each platform.

Mechanisms of plastic deformation, slip and twinning include:

A slip involves the sliding of blocks of crystal over one another along different crystallographic planes known as slip planes. In twinning, the portion of crystals takes up an orientation related to the orientation of the rest of the untwined lattice in a symmetrical and definite way.

Key features of Mechanisms of plastic deformation, slip and twinning :

Plastic deformation is the permanent distortion that occurs when a material is subjected to tensile, compressive, bending, or torsion stresses that exceed its yield strength and cause it to elongate, compress, buckle, bend, or twist.

FLUID MECHANICS AND MACHINERY

# FLUID MECHANICS AND MACHINERY

EDITED BY  
DR S P KALAISELVAN



978-93-6255-774-2

# FLUID MECHANICS AND MACHINERY

Fluid Mechanics and Machinery

Copyright © 2018-2019 by Dr. S P KALAISELVAN

All rights reserved. No part of this book may be reproduced or transmitted in any form or by any means without written permission from the author.

ISBN: 978-93-6255-774-2

Publisher: PRIST Publications.

# FLUID MECHANICS AND MACHINERY

	<b>TABLE OF CONTENTS</b>	
	Introduction	8
CHAPTER NO 1	Fluid Properties	12
<b>Dr. V YALINI</b>		
CHAPTER NO 2	Flow Through Pipes	49
<b>K PURUSHOTHAMAN</b>		
CHAPTER NO 3	Dimensional Analysis	88
<b>M SUDHAKAR</b>		
CHAPTER NO 4	Hydraulic Turbines	125
<b>P SARATH KUMAR</b>		
CHAPTER NO 5	Hydraulic Pumps	178
<b>N SIVAHARINATHAN</b>		
CHAPTER NO 6	Flow Characteristics	208
<b>J RAJESH</b>		
CHAPTER NO 7	Boundary Layer	232
<b>P VIJAYAKUMAR</b>		
CHAPTER NO 8	Model Studies in fluids	267
<b>G BRITHIVIRAJ</b>		
CHAPTER NO 9	Turbines	312
<b>Dr. S DHANUSKODI</b>		
CHAPTER NO 10	Pumps	340
<b>R TAMIZH SELVAN</b>		
REFERENCES		372

# FLUID MECHANICS AND MACHINERY

## CHAPTER 1

### Fluid Properties

Dr. V YALINI

**Fluids:** Substances capable of flowing are known as fluids. Flow is the continuous deformation of substances under the action of shear stresses.

Fluids have no definite shape of their own, but conform to the shape of the containing vessel. Fluids include liquids and gases.

#### **Fluid Mechanics:**

Fluid mechanics is the branch of science that deals with the behavior of fluids at rest as well as in motion. Thus, it deals with the static, kinematics and dynamic aspects of fluids.

The study of fluids at rest is called fluid statics. The study of fluids in motion, where pressure forces are not considered, is called fluid kinematics and if the pressure forces are also considered for the fluids in motion, that branch of science is called fluid dynamics.

#### **Fluid Properties:**

##### **1. Density (or) Mass Density:**

Density or mass density of a fluid is defined as the ratio of the mass of the fluid to its volume. Thus, *Mass per unit volume of a fluid is called density.*

$$\text{Mass density, } \rho = \frac{\text{Mass of fluid}}{\text{Volume of fluid}}$$

S.I unit of density is  $\text{kg/m}^3$ .  
The value of density for water is  $1000 \text{ kg/m}^3$ .

##### **2. Specific weight (or) Weight Density (w):**

Specific weight or weight density of a fluid is the ratio between the weight of a fluid to its volume.

*The weight per unit volume of a fluid is called specific weight or weight density.*

$$\begin{aligned} \text{Weight density} &= \frac{\text{Weight of fluid}}{\text{Volume of fluid}} \\ &= \frac{\text{Mass of fluid} \times g}{\text{Volume of fluid}} \\ w &= \rho g \end{aligned}$$

S.I unit of specific weight is  $\text{N/m}^3$ .  
The value of specific weight or weight density of water is  $9810 \text{ N/m}^3$  or  $9.81 \text{ kN/m}^3$ .

##### **3. Specific Volume (v):**

Specific volume of a fluid is defined as the volume of a fluid occupied by unit mass. *Volume per unit mass of a fluid is called Specific volume.*



# FLUID MECHANICS AND MACHINERY

## CHAPTER 2

### Flow through Pipes

K PURUSHOTHAMAN

#### Orifice

Orifice is a small opening on the side or at the bottom of a tank, through which a fluid is flowing. The orifices are classified according to the size, shape, nature of discharge and shape of the edge.

1. According to the size of orifice and head of liquid from the centre of the orifice:  
Small orifice and Large orifice.  
Small Orifice: If the head of liquid from the centre of orifice is more than five times the depth of orifice, the orifice is called small orifice.  
Large Orifice: If the head of liquid is less than five times the depth of orifice, it is known as large orifice.
2. According to shape of orifice: (i) Circular orifice, (ii) Triangular orifice, (iii) Rectangular orifice and (iv) Square orifice
3. According to their cross-sectional area or edge: (i) Sharp-edged orifice and (ii) Bell mouthed orifice

According to the discharge condition: (i) Free discharging orifices (ii) Fully drowned or submerged orifices and (iii) Partially submerged orifices.

#### Flow through a Small Orifice

Flow from a tank through a hole in the side.

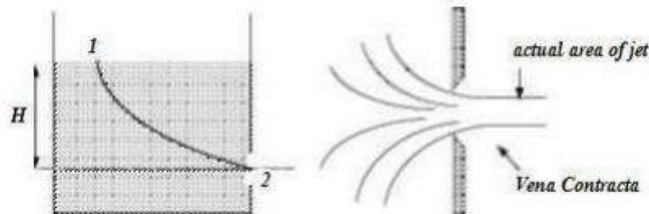

Fig.1. Flow through a small Orifice

The edges of the hole are sharp to minimize frictional losses by minimizing the contact between the hole and the liquid. The streamlines at the orifice contract reducing the area of flow. This contraction is called the vena contracta.

The amount of contraction must be known to calculate the flow.

Applying Bernoulli's equation along the streamline joining point 1 on the surface to point 2 at the centre of the orifice.

At the surface velocity is negligible ( $v_1 = 0$ ) and the pressure atmospheric ( $p_1 = \theta$ ). At the orifice the jet is open to the atmosphere so again the pressure is atmospheric ( $p_2 = 0$ ).

If we take the datum line through the orifice then  $Z_1 = H$  and  $Z_2 = 0$  leaving  $h = Z_1 - Z_2 = H$ . This theoretical value of velocity is an overestimate as friction losses have not been taken into account. A coefficient of velocity is used to correct the theoretical velocity,

Each orifice has its own coefficient of velocity, they usually lie in the range 0.97 - 0.99

The discharge through the orifice = jet area X jet velocity

The area of the jet is the area of the vena contracta and not the area of the orifice. We use a Coefficient of contraction to get the area of the

# FLUID MECHANICS AND MACHINERY

## CHAPTER 3

### Dimensional Analysis

M SUDHAKAR

#### Orifice

Orifice is a small opening on the side or at the bottom of a tank, through which a fluid is flowing. The orifices are classified according to the size, shape, nature of discharge and shape of the edge.

1. According to the size of orifice and head of liquid from the centre of the orifice:  
Small orifice and Large orifice.  
Small Orifice: If the head of liquid from the centre of orifice is more than five times the depth of orifice, the orifice is called small orifice.  
Large Orifice: If the head of liquid is less than five times the depth of orifice, it is known as large orifice.
2. According to shape of orifice: (i) Circular orifice, (ii) Triangular orifice, (iii) Rectangular orifice and (iv) Square orifice
3. According to their cross-sectional area or edge: (i) Sharp-edged orifice and (ii) Bell mouthed orifice

According to the discharge condition: (i) Free discharging orifices (ii) Fully drowned or submerged orifices and (iii) Partially submerged orifices.

#### Flow through a Small Orifice

Flow from a tank through a hole in the side.

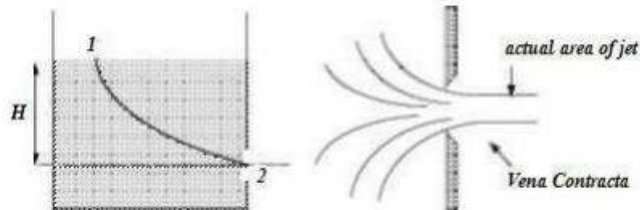

Fig.1. Flow through a small Orifice

The edges of the hole are sharp to minimize frictional losses by minimizing the contact between the hole and the liquid. The streamlines at the orifice contract reducing the area of flow. This contraction is called the vena contracta.

The amount of contraction must be known to calculate the flow.

Applying Bernoulli's equation along the streamline joining point 1 on the surface to point 2 at the centre of the orifice.

At the surface velocity is negligible ( $v_1 = 0$ ) and the pressure atmospheric ( $p_1 = \theta$ ). At the orifice the jet is open to the atmosphere so again the pressure is atmospheric ( $p_2 = 0$ ).

If we take the datum line through the orifice then  $Z_1 = H$  and  $Z_2 = 0$  leaving  $h = 2Z_2 = h = \sqrt{2}$

This theoretical value of velocity is an overestimate as friction losses have not been taken into account. A coefficient of velocity is used to correct the theoretical velocity,

Each orifice has its own coefficient of velocity, they usually lie in the range 0.97 - 0.99

The discharge through the orifice = jet area X jet velocity

The area of the jet is the area of the vena contracta and not the area of the orifice. We use a Coefficient of contraction to get the area of the



# FLUID MECHANICS AND MACHINERY

## CHAPTER 4

### Hydraulic Turbines

P SARATH KUMAR

#### **TURBINES**

Hydraulic machines are defined as those machines which convert either hydraulic energy (energy possessed by water) into mechanical energy (which is further converted into electrical energy) or mechanical energy into hydraulic energy. The hydraulic machines, which convert the hydraulic energy into mechanical energy, are called turbines while the hydraulic machines which convert the mechanical energy into hydraulic energy. The study of hydraulic machines consists of turbines and pumps.

Turbines are defined as the hydraulic machines which convert hydraulic energy into mechanical energy. This, mechanical energy is used in running an electric generator which is directly coupled to the shaft of the turbine. Thus the mechanical energy is converted into electrical energy. The electric power which is obtained from the hydraulic energy (energy of water) is known as Hydroelectric power. At present the generation of hydroelectric power is the cheapest as compared by the power generated by other sources such as oil, coal etc.

#### **General Layout of a Hydroelectric Power Plant**

1. A dam constructed across a river to store water.
2. Pipes of large diameters called penstocks, which carry water under pressure from the storage reservoir to the turbines. These pipes are made of steel or reinforced concrete.
3. Turbines having different types of vanes fitted to the wheels.
4. Tail race, which is a channel which carries water away from the turbines after the water has worked on the turbines. The surface of water in the tail race channel is also known as tail race.

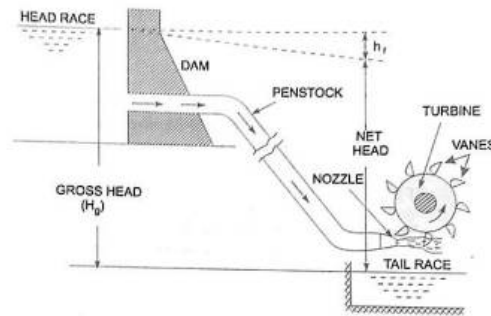

**Fig. Layout of hydroelectric power plant**

#### **Definitions of Heads and Efficiencies of a Turbine**

1. Gross Head. The difference between the head race level and tail race level when no water is flowing is known as Gross Head. It is denoted by 'H<sub>g</sub>'.
2. Net Head. It is also called effective head and is defined as the head available at the inlet of the turbine, when water is flowing from head race to the turbine, a loss of head due to friction between water and penstock occurs. Though there are other losses also such as loss due to bend, Pipes, fittings, loss at the entrance of penstock etc., yet they are having small magnitude as compared to head loss due to friction. In 'h<sub>f</sub>' is the head loss due to friction between penstocks and water then net head on turbine is given by

$$H = H_g - h_f$$

# FLUID MECHANICS AND MACHINERY

## CHAPTER 5

### Hydraulic Pumps

N SIVAHARINATHAN

#### Hydraulic Pump

A hydraulic pump is a mechanical source of power that converts mechanical power into hydraulic energy. It generates flow with enough power to overcome pressure induced by the load at the pump outlet. When a hydraulic pump operates, it creates a vacuum at the pump inlet, which forces liquid from the reservoir into the inlet line to the pump and by mechanical action delivers this liquid to the pump outlet and forces it into the hydraulic system.

#### Classifications of Pump

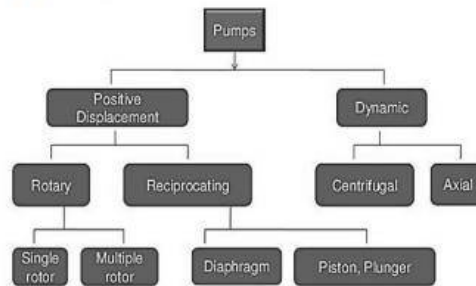

#### Centrifugal Pump

The main components of a centrifugal pump are:

- i) Impeller
- ii) Casing
- iii) Suction pipe
- iv) Foot valve with strainer,
- v) Delivery pipe
- vi) Delivery valve.

**Impeller** is the rotating component of the pump. It is made up of a series of curved vanes. The impeller is mounted on the shaft connecting an electric motor.

**Casing** is an air tight chamber surrounding the impeller. The shape of the casing is designed in such a way that the kinetic energy of the impeller is gradually changed to potential energy. This is achieved by gradually increasing the area of cross section in the direction of flow.

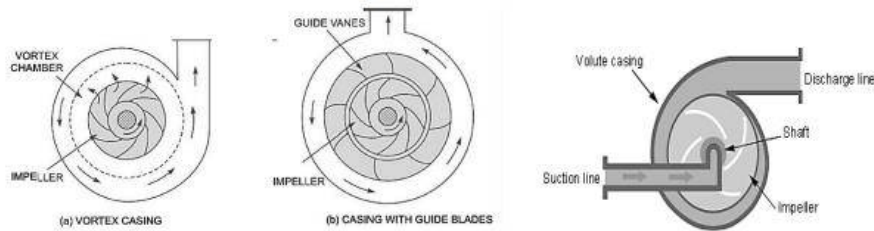

Fig. 1 Types of Casing

**Suction pipe:** It is the pipe connecting the pump to the sump, from where the liquid has to be lifted up.

# FLUID MECHANICS AND MACHINERY

## CHAPTER 6

### Flow Characteristics

J RAJESH

**Fluids:** Substances capable of flowing are known as fluids. Flow is the continuous deformation of substances under the action of shear stresses.

Fluids have no definite shape of their own, but conform to the shape of the containing vessel. Fluids include liquids and gases.

#### **Fluid Mechanics:**

Fluid mechanics is the branch of science that deals with the behavior of fluids at rest as well as in motion. Thus, it deals with the static, kinematics and dynamic aspects of fluids.

The study of fluids at rest is called fluid statics. The study of fluids in motion, where pressure forces are not considered, is called fluid kinematics and if the pressure forces are also considered for the fluids in motion, that branch of science is called fluid dynamics.

#### **Fluid Properties:**

##### **1. Density (or) Mass Density:**

Density or mass density of a fluid is defined as the ratio of the mass of the fluid to its volume. Thus, *Mass per unit volume of a fluid is called density.*

$$\text{Mass density, } \rho = \frac{\text{Mass of fluid}}{\text{Volume of fluid}}$$

**S.I unit of density is kg/m<sup>3</sup>.**  
The value of density for water is 1000 kg/m<sup>3</sup>.

##### **2. Specific weight (or) Weight Density (w):**

Specific weight or weight density of a fluid is the ratio between the weight of a fluid to its volume.

*The weight per unit volume of a fluid is called specific weight or weight density.*

$$\begin{aligned} \text{Weight density} &= \frac{\text{Weight of fluid}}{\text{Volume of fluid}} \\ &= \frac{\text{Mass of fluid} \times g}{\text{Volume of fluid}} \\ w &= \rho g \end{aligned}$$

**S.I unit of specific weight is N/m<sup>3</sup>.**  
The value of specific weight or weight density of water is 9810 N/m<sup>3</sup> or 9.81 kN/m<sup>3</sup>.

##### **3. Specific Volume (v):**

Specific volume of a fluid is defined as the volume of a fluid occupied by unit mass. *Volume per unit mass of a fluid is called Specific volume.*



# FLUID MECHANICS AND MACHINERY

## CHAPTER 7

### Boundary Layer

P VIJAYAKUMAR

Fluid flow is described by two methods: Lagrangian method & Eulerian method. In the Lagrangian method a single particle is followed over the flow field with the coordinate system following the particle. The flow description is particle based and not space based. A moving coordinate system has to be used. In the Eulerian method, the description of flow is based on fixed coordinate system and the description of the velocity is with reference to location and time. Hence, Eulerian approach is easily adoptable to describe fluid motion mathematically.

#### Control Volume:

A fixed volume in space whose size and shape is entirely arbitrary, through which a fluid is continuously flowing is known as *control volume*. The boundary of a control volume is termed as the *control surface*. The size and shape is arbitrary and normally chosen such that it encloses part of the flow of particular interest.

#### Types of Fluid Flow:

**1) Steady flow:** The flow in which the fluid characteristics like velocity, pressure, density etc. at a point do not change with time is defined as steady flow.

Mathematically, for steady flow,

$$\left(\frac{\partial v}{\partial t}\right)_{x_0, y_0, z_0} = 0, \left(\frac{\partial p}{\partial t}\right)_{x_0, y_0, z_0} = 0, \left(\frac{\partial \rho}{\partial t}\right)_{x_0, y_0, z_0} = 0$$

**Unsteady Flow:** The flow, in which the velocity, pressure and density at a point changes with respect to time is defined as unsteady flow.

Mathematically, for unsteady flow

$$\left(\frac{\partial v}{\partial t}\right)_{x_0, y_0, z_0} \neq 0, \left(\frac{\partial p}{\partial t}\right)_{x_0, y_0, z_0} \neq 0 \text{ etc.}$$

**2. Uniform flows:** The flow in which the velocity at any given time does not change with respect to distance is defined as Uniform flow.

Mathematically, for uniform flow

$$\left(\frac{\partial v}{\partial s}\right)_{t = \text{constant}} = 0$$

**Non-uniform flow:** The flow in which the velocity at any given time changes with respect to distance is defined as non uniform flow.

Mathematically, for non-uniform flow,

$$\left(\frac{\partial v}{\partial s}\right)_{t = \text{constant}} \neq 0.$$

**3. Laminar flow:** The flow in which the fluid particles move along well-defined paths which are straight and parallel is defined as laminar flow. Thus the particles move in layers and do not cross each other.

**Turbulent flow:** The flow in which the fluid particles do not move in a zig-zag way and the adjacent layers cross each other is defined as turbulent flow.

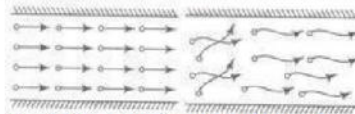

Fig. 1. Laminar & Turbulent Flow

**4. Compressible flow:** The flow in which the density of fluid changes from point to point i.e.,  $\rho$  is not constant for the fluid, is defined as compressible flow.

Prepared with the help of computer software.

# FLUID MECHANICS AND MACHINERY

## CHAPTER 8

### Boundary Layer

#### G BRITHIVIRAJ

##### Orifice

Orifice is a small opening on the side or at the bottom of a tank, through which a fluid is flowing. The orifices are classified according to the size, shape, nature of discharge and shape of the edge.

1. According to the size of orifice and head of liquid from the centre of the orifice: Small orifice and Large orifice.  
Small Orifice: If the head of liquid from the centre of orifice is more than five times the depth of orifice, the orifice is called small orifice.  
Large Orifice: If the head of liquid is less than five times the depth of orifice, it is known as large orifice.
2. According to shape of orifice: (i) Circular orifice, (ii) Triangular orifice, (iii) Rectangular orifice and (iv) Square orifice
3. According to their cross-sectional area or edge: (i) Sharp-edged orifice and (ii) Bell mouthed orifice

According to the discharge condition: (i) Free discharging orifices (ii) Fully drowned or submerged orifices and (iii) Partially submerged orifices.

##### Flow through a Small Orifice

Flow from a tank through a hole in the side.

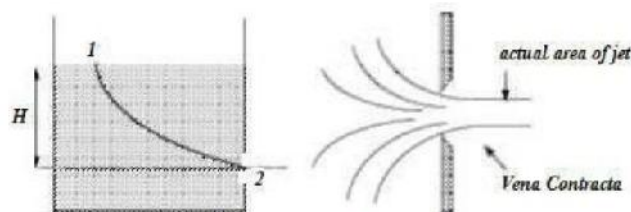

Fig.1. Flow through a small Orifice

The edges of the hole are sharp to minimize frictional losses by minimizing the contact between the hole and the liquid. The streamlines at the orifice contract reducing the area of flow. This contraction is called the vena contracta.

The amount of contraction must be known to calculate the flow.

Applying Bernoulli's equation along the streamline joining point 1 on the surface to point 2 at the centre of the orifice.

At the surface velocity is negligible ( $v_1 = 0$ ) and the pressure atmospheric ( $p_1 = 0$ ). At the orifice the jet is open to the atmosphere so again the pressure is atmospheric ( $p_2 = 0$ ).

If we take the datum line through the orifice then  $Z_1 = H$  and  $Z_2 = 0$  leaving  $h = 2Z_2 = h = \sqrt{2}$

This theoretical value of velocity is an overestimate as friction losses have not been taken into account. A coefficient of velocity is used to correct the theoretical velocity.

Each orifice has its own coefficient of velocity, they usually lie in the range 0.97 - 0.99

The discharge through the orifice = jet area X jet velocity

The area of the jet is the area of the vena contracta and not the area of the orifice. We use a Coefficient of contraction to get the area of the

# FLUID MECHANICS AND MACHINERY

## CHAPTER 9

### Turbines

Dr.S.DHANUSKODI

#### *TURBINES*

Hydraulic machines are defined as those machines which convert either hydraulic energy (energy possessed by water) into mechanical energy (which is further converted into electrical energy) or mechanical energy into hydraulic energy. The hydraulic machines, which convert the hydraulic energy into mechanical energy, are called turbines while the hydraulic machines which convert the mechanical energy into hydraulic energy. The study of hydraulic machines consists of turbines and pumps.

Turbines are defined as the hydraulic machines which convert hydraulic energy into mechanical energy. This, mechanical energy is used in running an electric generator which is directly coupled to the shaft of the turbine. Thus the mechanical energy is converted into electrical energy. The electric power which is obtained from the hydraulic energy (energy of water) is known as Hydroelectric power. At present the generation of hydroelectric power is the cheapest as compared by the power generated by other sources such as oil, coal etc.

#### **General Layout of a Hydroelectric Power Plant**

1. A dam constructed across a river to store water.
2. Pipes of large diameters called penstocks, which carry water under pressure from the storage reservoir to the turbines. These pipes are made of steel or reinforced concrete.
3. Turbines having different types of vanes fitted to the wheels.
4. Tail race, which is a channel which carries water away from the turbines after the water has worked on the turbines. The surface of water in the tail race channel is also known as tail race.

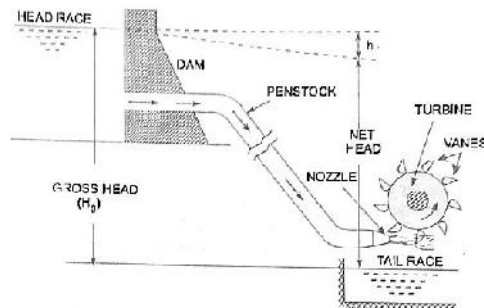

**Fig. Layout of hydroelectric power plant**

#### **Definitions of Heads and Efficiencies of a Turbine**

1. Gross Head. The difference between the head race level and tail race level when no water is flowing is known as Gross Head. It is denoted by 'H<sub>g</sub>'.
2. Net Head. It is also called effective head and is defined as the head available at the inlet of the turbine, when water is flowing from head race to the turbine, a loss of head due to friction between water and penstock occurs. Though there are other losses also such as loss due to bend, Pipes, fittings, loss at the entrance of penstock etc., yet they are having small magnitude as compared to head loss due to friction. In 'h<sub>f</sub>' is the head loss due to friction between penstocks and water then net head on turbine is given by

$$H = H_g - h_f$$



# FLUID MECHANICS AND MACHINERY

## CHAPTER 10

### Pumps

R TAMIZH SELVAN

#### Hydraulic Pump

A hydraulic pump is a mechanical source of power that converts mechanical power into hydraulic energy. It generates flow with enough power to overcome pressure induced by the load at the pump outlet. When a hydraulic pump operates, it creates a vacuum at the pump inlet, which forces liquid from the reservoir into the inlet line to the pump and by mechanical action delivers this liquid to the pump outlet and forces it into the hydraulic system.

#### Classifications of Pump

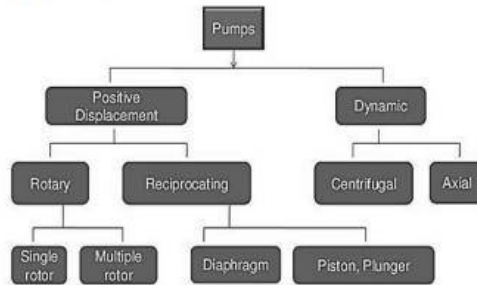

#### Centrifugal Pump

The main components of a centrifugal pump are:

- i) Impeller
- ii) Casing
- iii) Suction pipe
- iv) Foot valve with strainer,
- v) Delivery pipe
- vi) Delivery valve.

**Impeller** is the rotating component of the pump. It is made up of a series of curved vanes. The impeller is mounted on the shaft connecting an electric motor.

**Casing** is an air tight chamber surrounding the impeller. The shape of the casing is designed in such a way that the kinetic energy of the impeller is gradually changed to potential energy. This is achieved by gradually increasing the area of cross section in the direction of flow.

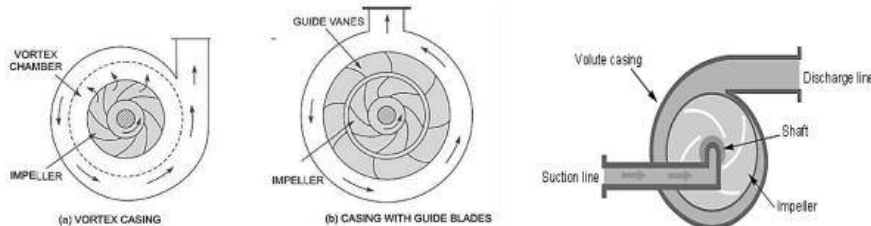

Fig. 1 Types of Casing

**Suction pipe:** It is the pipe connecting the pump to the sump, from where the liquid has to be lifted up.



# **PEDAGOGY OF PHYSICAL SCIENCE: PART - II**

Edited by

**DR.R.GUNASEKARAN**



978-93-6255-181-8

Pedagogy of Physical Science: Part - II  
Copyright ©2018-2019 by Dr.R. Gunasekaran

All rights reserved. No part of this book may be reproduced or transmitted in any form or by any means without written permission from the author.

ISBN:978-93-6255-181-8

Publisher: Ponnaiyah Ramajayam Institute of Science and Technology (PRIST)

## TABLE OF CONTENTS

Introduction .....	5
CHAPTER I Pedagogical Analysis .....	15
DR. R. GUNASEKARAN	
CHAPTER 2 Models of Teaching.....	27
DR. D. MURUGANANTHAM	
CHAPTER 3 Activity-Based and Group Controlled Instruction .....	45
DR. D. MURUGANANTHAM	
CHAPTER 4 Learning Resources .....	68
DR. A. NAGEEMA	
CHAPTER 5 Assessment in Pedagogy of Physical Science.....	80
DR. R. GUNASEKARAN	
CHAPTER 6 Aids for Teaching Physical Science .....	95
DR. R. GUNASEKARAN	
CHAPTER 7 Evaluation .....	126
DR. R. GUNASEKARAN	
CHAPTER 8 Planning for Instruction .....	135
Prof. T. SELVARAJ	
CHAPTER 9 Models of Teaching .....	155
Prof. R. VAISHNAVI	
CHAPTER 10 The Science Teacher.....	162
DR. R. GUNASEKARAN	
REFERENCES.....	172

## **CHAPTER I** **Pedagogical Analysis**

**DR. R. GUNASEKARAN**  
Assistant professor, School of Education,  
PRIST Deemed to Be University, Thanjavur.

A **pedagogical analysis** involves the detailed examination of teaching methods, learning activities, and educational processes. This type of analysis focuses on understanding how educational goals are achieved and how learning experiences are designed, implemented, and evaluated. It's essential for improving teaching strategies, developing curriculum, and enhancing student learning outcomes.

### **Key Components of Pedagogical Analysis:**

1. **Learning Objectives:**
  - Analysis begins with identifying clear learning goals.
  - Are the objectives aligned with the needs of the students and the subject matter?
2. **Teaching Methods:**
  - What teaching approaches are being used (e.g., lecture, discussion, problem-solving, hands-on activities)?
  - Are these methods effective for the intended learning outcomes?
3. **Learning Theories:**
  - Which learning theories (e.g., behaviorism, constructivism, cognitivism) underpin the pedagogical approach?
  - Are these theories applied in a way that supports diverse learners?
4. **Content Structure and Delivery:**
  - Is the curriculum content organized in a logical, accessible way?
  - How is the content delivered—through direct instruction, multimedia, collaborative activities, etc.?
5. **Assessment and Evaluation:**
  - Are the assessment tools (quizzes, exams, projects) aligned with the learning objectives?
  - Is there a balance between formative (ongoing) and summative (final) assessments?
6. **Learner Engagement:**
  - How does the teaching approach engage students?
  - Are interactive or experiential learning opportunities provided?
7. **Student-Centeredness:**
  - Is the pedagogy flexible and adaptable to meet the individual needs of students?
  - Does it account for varying learning styles, backgrounds, and abilities?
8. **Technological Integration:**
  - How is technology being used to support learning?
  - Are online tools or digital resources appropriately incorporated?
9. **Classroom Environment:**

**CHAPTER 2**  
**Models of Teaching**  
**DR. D. MURUGANANTHAM**  
**Associate professor, School of Education,**  
**PRIST Deemed to Be University, Thanjavur.**

Here's a concise overview of various models of teaching, focusing on their key characteristics, advantages, and examples:

### **1. Direct Instruction Model**

- **Characteristics:** Teacher-centered; structured lessons; clear objectives; step-by-step guidance.
- **Advantages:** Efficient for delivering information; effective for skill acquisition; suitable for large groups.
- **Example:** Teaching the structure of DNA through a lecture, followed by guided practice in labeling diagrams.

### **2. Inquiry-Based Learning Model**

- **Characteristics:** Student-centered; promotes questioning and exploration; emphasizes the scientific method.
- **Advantages:** Fosters critical thinking and problem-solving; encourages student engagement and ownership of learning.
- **Example:** Students investigate local ecosystems, formulate hypotheses, and conduct experiments to test their ideas.

### **3. Cooperative Learning Model**

- **Characteristics:** Collaborative group work; positive interdependence; individual accountability.
- **Advantages:** Develops teamwork and social skills; enhances understanding through peer learning.
- **Example:** Small groups research different aspects of a biological topic (e.g., photosynthesis) and present findings to the class.

### **4. Problem-Based Learning (PBL) Model**

- **Characteristics:** Students learn through solving real-world problems; requires research and collaboration.
- **Advantages:** Connects learning to practical applications; develops critical thinking and research skills.
- **Example:** Students create a conservation plan for a local endangered species, researching ecological impacts and solutions.

## CHAPTER 3 Activity-Based and Group Controlled Instruction

**DR. D. MURUGANANTHAM**  
Associate professor, School of Education,  
PRIST Deemed to Be University, Thanjavur.

**Activity-Based Learning (ABL)** and **Group Controlled Instruction** are teaching methods that prioritize active student engagement and collaboration. They focus on learning by doing, rather than passive reception of knowledge, and are particularly effective in fostering critical thinking, teamwork, and practical problem-solving skills.

### 1. Activity-Based Learning (ABL)

**Definition:** Activity-Based Learning emphasizes learning through hands-on activities and real-world experiences. It shifts the focus from passive learning (e.g., lectures) to student-centered activities that require exploration, interaction, and application of knowledge.

#### Key Features:

- **Student-Centered:** Students take an active role in their learning through participation in activities.
- **Experiential Learning:** Activities are often based on real-life situations, fostering practical understanding.
- **Inquiry and Exploration:** Encourages students to ask questions, investigate, and find solutions on their own.
- **Variety of Activities:** Includes experiments, role-playing, simulations, games, field trips, and creative projects.
- **Skills Focus:** Promotes the development of soft skills (e.g., communication, collaboration) alongside academic skills.

#### Process:

1. **Introduction of Concepts:** Brief introduction of the topic or concept by the teacher.
2. **Activity Implementation:** Students engage in hands-on tasks designed to explore or apply the concept.
3. **Exploration and Discovery:** Through the activity, students make observations, gather data, or create a product.
4. **Discussion and Reflection:** Students share their findings or experiences, reflecting on what they learned.
5. **Evaluation and Feedback:** The teacher assesses the students' performance, provides feedback, and clarifies any misunderstandings.

#### Benefits:

## CHAPTER 4 Learning Resources

**DR. A. NAGEEMA**  
Assistant professor, School of Education,  
PRIST Deemed to Be University, Thanjavur.

**Learning resources** are materials, tools, and content that help facilitate and support learning across various educational settings. These resources can take many forms, from traditional textbooks to digital media, providing opportunities for students to explore subjects in diverse and engaging ways. Effective learning resources cater to different learning styles, promote active learning, and foster understanding of the subject matter.

### Categories of Learning Resources

#### 1. Text-Based Resources

- **Textbooks:** Traditional, structured materials that provide comprehensive information on specific subjects.
- **Articles and Journals:** Academic papers and research articles that offer in-depth information and current research.
- **E-Books:** Digital versions of books that can be accessed on various devices, offering flexibility and additional features like search functions.
- **Workbooks and Study Guides:** Printed or digital materials designed for practice and self-assessment.

#### 2. Visual Resources

- **Diagrams and Charts:** Visual representations of information, such as flowcharts, mind maps, and infographics, which simplify complex concepts.
- **Posters and Flashcards:** Materials that provide quick reference to key concepts, useful for memorization and review.
- **Presentations:** Slide-based resources (e.g., PowerPoint, Google Slides) used to present ideas in a structured, visual format.
- **Videos:** Educational videos, documentaries, or tutorials that explain concepts visually and often in a more engaging way.

#### 3. Audio Resources

- **Podcasts:** Audio programs focused on specific subjects, allowing students to learn by listening.
- **Audiobooks:** Audio versions of books that provide an alternative for auditory learners or those who prefer to learn on the go.
- **Recorded Lectures:** Audio recordings of in-class lectures or online lessons, which provide an opportunity to review content or catch up on missed material.

#### 4. Digital and Interactive Resources

- **Educational Websites:** Online platforms such as Khan Academy, Coursera, or TED-Ed that offer lessons, quizzes, and tutorials.
- **Learning Management Systems (LMS):** Platforms like Moodle, Google Classroom, or Canvas, which organize resources, track progress, and facilitate communication between teachers and students.



**CHAPTER 5**  
**Assessment in Pedagogy of Physical Science**  
**DR. R. GUNASEKARAN**  
**Assistant professor, School of Education,**  
**PRIST Deemed to Be University, Thanjavur.**

Assessment in the pedagogy of physical science involves evaluating students' understanding and skills in concepts such as physics, chemistry, and earth science. Here are some key aspects:

1. **Formative Assessment:** Ongoing assessments like quizzes, class discussions, and hands-on experiments help gauge students' grasp of material and provide immediate feedback.
2. **Summative Assessment:** End-of-unit tests, projects, or standardized tests measure cumulative knowledge and understanding.
3. **Practical Assessments:** Lab experiments and demonstrations assess students' ability to apply theoretical knowledge in practical settings.
4. **Peer Assessment:** Involving students in assessing each other's work fosters collaborative learning and critical thinking.
5. **Self-Assessment:** Encouraging students to reflect on their learning process helps them develop metacognitive skills.
6. **Diverse Formats:** Using a mix of written assignments, presentations, and creative projects can cater to different learning styles and strengths.
7. **Use of Technology:** Tools like simulations, online quizzes, and educational apps can enhance engagement and provide immediate feedback.
8. **Alignment with Standards:** Ensuring assessments align with educational standards and learning objectives helps maintain focus on essential content.

Effective assessment in physical science not only measures knowledge but also promotes critical thinking, problem-solving, and the application of scientific concepts in real-world contexts.

## CHAPTER 6

### Aids for Teaching Physical Science

DR. R. GUNASEKARAN

Assistant professor, School of Education,  
PRIST Deemed to Be University, Thanjavur.

Teaching physical science can be enhanced with a variety of aids and resources. Here are some effective aids:

- 1. Visual Aids:**
  - **Posters and Charts:** Use colorful posters to illustrate concepts like the periodic table, force diagrams, or the water cycle.
  - **Infographics:** These can simplify complex information and make it more digestible.
- 2. Models and Simulations:**
  - **3D Models:** Physical models of atoms, molecules, or planetary systems help students visualize structures and relationships.
  - **Computer Simulations:** Software like PhET Interactive Simulations allows students to experiment with concepts in a virtual environment.
- 3. Lab Equipment:**
  - **Basic Laboratory Tools:** Beakers, Bunsen burners, and measuring devices are essential for hands-on experiments.
  - **Safety Equipment:** Goggles, gloves, and lab coats ensure a safe learning environment.
- 4. Multimedia Resources:**
  - **Videos and Documentaries:** Engaging content from platforms like YouTube or educational channels can enhance understanding of complex topics.
  - **Interactive Whiteboards:** These can be used to present dynamic content and encourage student interaction.
- 5. Online Resources:**
  - **Educational Websites:** Websites like Khan Academy or National Geographic provide valuable information and interactive activities.
  - **Virtual Labs:** Online platforms that allow students to conduct experiments safely and effectively.
- 6. Field Trips:**
  - Visits to science museums, planetariums, or local industries can provide real-world connections to physical science concepts.
- 7. Science Kits:**
  - Pre-packaged science kits that include experiments and materials can simplify lesson planning and make learning fun.
- 8. Books and Journals:**
  - Textbooks, reference books, and science journals offer in-depth information and current research findings.
- 9. Collaborative Tools:**

## CHAPTER 7

### Evaluation

**DR. R. GUNASEKARAN**  
Assistant professor, School of Education,  
PRIST Deemed to Be University, Thanjavur.

**Evaluation** in the context of education refers to the systematic process of assessing the effectiveness of teaching, learning, and educational strategies. It involves gathering and analyzing data to determine how well students are learning, how effectively instructional methods are working, and how educational objectives are being met. In the pedagogy of biological science, evaluation helps educators refine their teaching practices, assess student progress, and improve the curriculum.

### Types of Evaluation in Education

#### 1. Formative Evaluation

- **Definition:** Ongoing evaluations conducted during the teaching-learning process.
- **Purpose:** To monitor student learning and provide feedback that can be used to improve instruction and learning in real-time.
- **Examples:**
  - Classroom quizzes
  - Group discussions
  - Short feedback forms
  - Student reflections
- **Benefits:** Helps teachers adjust their teaching methods, address student misconceptions early, and guide students toward achieving learning goals.

#### 2. Summative Evaluation

- **Definition:** Evaluation conducted at the end of a unit, course, or program to assess the overall effectiveness and achievement.
- **Purpose:** To evaluate student learning at the conclusion of an instructional period and to determine if the learning objectives were met.
- **Examples:**
  - Final exams
  - End-of-term projects
  - Standardized tests
  - Cumulative reports
- **Benefits:** Provides a comprehensive measure of student performance and curriculum effectiveness. Summative evaluations often inform grades and certifications.

#### 3. Diagnostic Evaluation

- **Definition:** Pre-assessment conducted before instruction begins to understand students' prior knowledge and identify learning needs.
- **Purpose:** To identify strengths, weaknesses, and areas for improvement before the learning process starts.

## CHAPTER 8

### Planning for Instruction Prof. T. SELVARAJ

**Planning for instruction** is a vital component of effective teaching, as it involves organizing and designing lessons to meet learning objectives, address student needs, and ensure that the content is delivered effectively. In the context of biological science, instructional planning focuses on how to best teach scientific concepts, theories, and skills, ensuring that students can not only understand the material but also apply it to real-world scenarios.

#### Key Steps in Planning for Instruction

##### 1. Define Learning Objectives

- **Purpose:** Clear learning objectives outline what students should know, understand, and be able to do by the end of the lesson or unit.
- **Examples:**
  - "Students will be able to explain the process of photosynthesis."
  - "Students will analyze the role of natural selection in evolution."
- **SMART Criteria:** Learning objectives should be **S**pecific, **M**easurable, **A**chievable, **R**elevant, and **T**ime-bound to ensure clarity and focus.

##### 2. Identify and Align Curriculum Standards

- **Purpose:** Instruction must align with national, state, or local curriculum standards to ensure consistency and comprehensiveness.
- **Examples:** For biology, this may include standards related to genetics, ecosystems, evolution, and cell biology.
- **Benefits:** Ensures that instruction covers essential content and skills, helping students meet academic expectations.

##### 3. Understand Student Needs and Context

- **Purpose:** Tailoring instruction to meet the diverse needs of learners.
- **Considerations:**
  - **Learning styles:** Some students may be visual learners, while others prefer hands-on activities or verbal instruction.

## CHAPTER 9

### Models

Prof. R. VAISHNAVI

Assistant professor, School of Education,  
PRIST Deemed to Be University, Thanjavur.

**Models of teaching** refer to structured, systematic approaches to instruction that help guide the teaching process to achieve specific learning outcomes. These models are based on theories of learning and development and provide educators with frameworks for organizing and delivering content, fostering student engagement, and promoting the effective acquisition of knowledge and skills. Each model emphasizes different aspects of learning and teaching, and the choice of model depends on the subject matter, learning objectives, and the needs of the students.

Here are some of the most widely recognized models of teaching:

#### 1. The Direct Instruction Model

- **Definition:** A teacher-centered approach that emphasizes clear, structured, and explicit teaching of content or skills.
- **Key Features:**
  - Focus on mastery of content through systematic instruction.
  - The teacher leads the lesson by providing information, modeling, and giving guided practice.
  - Frequent feedback and correction are given to ensure understanding.
  - Lesson phases: Introduction, Presentation, Guided Practice, Independent Practice, and Closure.
- **Advantages:**
  - Highly effective for teaching foundational skills, especially in areas like math, reading, or basic biology concepts.
  - Structured and efficient, which makes it ideal for covering large amounts of content.
- **Disadvantages:**
  - Less emphasis on critical thinking and creativity.
  - Limits student autonomy and may not engage all learners.

**Example in Biology:** Teaching the structure of the cell by explaining and modeling the parts, providing guided practice through labeling exercises, and then assigning independent activities like cell diagram creation.

#### 2. The Inquiry-Based Learning Model

- **Definition:** A student-centered approach that encourages students to ask questions, investigate problems, and discover answers through exploration.

## CHAPTER 10

**The Physical Science Teacher**  
**DR. R. GUNASEKARAN**  
Assistant professor, School of Education,  
PRIST Deemed to Be University, Thanjavur.

A physical science teacher plays a crucial role in guiding students to understand and appreciate the principles of physics and chemistry, and their applications in the natural world. Their responsibilities go beyond simply delivering content; they are facilitators of scientific thinking, inquiry, and experimentation. Here are key qualities and roles of an effective physical science teacher:

### 1. Subject Expertise:

- **In-depth Knowledge:** A physical science teacher must have a strong understanding of key concepts in both physics and chemistry, including forces, energy, matter, and their interactions.
- **Keeping Updated:** Staying informed about advancements in science and technology is essential to provide students with current, relevant information.

### 2. Instructional Skills:

- **Clear Communication:** The teacher needs to simplify complex ideas and present them in ways that are easy for students to grasp.
- **Diverse Teaching Methods:** Using a variety of teaching techniques—such as demonstrations, experiments, discussions, and digital tools—helps cater to different learning styles.
- **Differentiation:** Adapting lessons for diverse student needs ensures all students can engage meaningfully with the content.

### 3. Encouraging Inquiry and Critical Thinking:

- **Inquiry-Based Learning:** A physical science teacher fosters curiosity by encouraging students to ask questions, explore hypotheses, and conduct experiments.
- **Problem-Solving Approach:** Emphasizing critical thinking and the scientific method helps students develop problem-solving skills, important in science and life.

### 4. Practical Application:

- **Lab Work and Experiments:** Engaging students in hands-on activities in the lab helps them apply theoretical knowledge, understand scientific processes, and develop lab skills.
- **Real-World Connections:** A teacher must connect classroom learning with real-world phenomena, making the subject matter relevant and relatable.



# **PEDAGOGY OF MATHEMATICS : PART- II**

EDITED BY

DR. M.ARON ANTONY CHARLES



978-93-6255-455-0

Pedagogy of Mathematics: Part - II  
Copyright ©2018-2019 by Dr. M. Aron Antony Charles

All rights reserved. No part of this book may be reproduced or transmitted in any form or by any means without written permission from the author.

ISBN:978-93-6255-455-0

Publisher: Ponnaiyah Ramajayam Institute of Science and Technology (PRIST)



## TABLE OF CONTENTS

Introduction .....	5
CHAPTER I Pedagogical Analysis .....	15
DR. M. ARON ANTONY CHARLES	
CHAPTER 2 Teaching Models.....	27
DR. R. GUNASEKARAN	
CHAPTER 3 Activity-Based and Group Controlled Instructions .....	45
Prof. T. SELVARAJ	
CHAPTER 4 Resource - Based Learning.....	68
DR. R. GUNASEKARAN	
CHAPTER 5 Assessment in Pedagogy of Mathematics.....	80
Prof. T. SELVARAJ	
CHAPTER 6 Aids for Teaching Mathematics .....	95
DR. R. GUNASEKARAN	
CHAPTER 7 Evaluation .....	126
DR. R. GUNASEKARAN	
CHAPTER 8 Planning for Instruction .....	135
Prof. T. SELVARAJ	
CHAPTER 9 Models .....	155
Prof. R. VAISHNAVI	
CHAPTER 10 The Mathematics Teacher.....	162
Prof. T. SELVARAJ	
REFERENCES.....	172

## **CHAPTER I** **Pedagogical Analysis**

**DR. M. ARON ANTONY CHARLES**  
**Associate professor, School of Education,**  
**PRIST Deemed to Be University, Thanjavur.**

A **pedagogical analysis** involves the detailed examination of teaching methods, learning activities, and educational processes. This type of analysis focuses on understanding how educational goals are achieved and how learning experiences are designed, implemented, and evaluated. It's essential for improving teaching strategies, developing curriculum, and enhancing student learning outcomes.

### **Key Components of Pedagogical Analysis:**

1. **Learning Objectives:**
  - Analysis begins with identifying clear learning goals.
  - Are the objectives aligned with the needs of the students and the subject matter?
2. **Teaching Methods:**
  - What teaching approaches are being used (e.g., lecture, discussion, problem-solving, hands-on activities)?
  - Are these methods effective for the intended learning outcomes?
3. **Learning Theories:**
  - Which learning theories (e.g., behaviorism, constructivism, cognitivism) underpin the pedagogical approach?
  - Are these theories applied in a way that supports diverse learners?
4. **Content Structure and Delivery:**
  - Is the curriculum content organized in a logical, accessible way?
  - How is the content delivered—through direct instruction, multimedia, collaborative activities, etc.?
5. **Assessment and Evaluation:**
  - Are the assessment tools (quizzes, exams, projects) aligned with the learning objectives?
  - Is there a balance between formative (ongoing) and summative (final) assessments?
6. **Learner Engagement:**
  - How does the teaching approach engage students?
  - Are interactive or experiential learning opportunities provided?
7. **Student-Centeredness:**
  - Is the pedagogy flexible and adaptable to meet the individual needs of students?
  - Does it account for varying learning styles, backgrounds, and abilities?
8. **Technological Integration:**
  - How is technology being used to support learning?
  - Are online tools or digital resources appropriately incorporated?
9. **Classroom Environment:**

## CHAPTER 2 Teaching Models

**DR. R. GUNASEKARAN**  
Assistant professor, School of Education,  
PRIST Deemed to Be University, Thanjavur.

**Teaching models** are structured frameworks or strategies used by educators to deliver instruction in a way that promotes learning and helps achieve educational goals. These models often align with specific pedagogical theories and approaches. Below are some widely recognized teaching models:

### 1. Direct Instruction Model

- **Description:** Teacher-centered, structured, and systematic approach where the teacher leads the class through explicit teaching, often in a step-by-step process.
- **Process:**
  - Introduction and review of prior learning.
  - Presentation of new material through lectures or demonstrations.
  - Guided practice with feedback.
  - Independent practice.
  - Assessment.
- **Best For:** Subjects that require rote memorization, skill-building, and learning foundational concepts (e.g., math, grammar).
- **Theoretical Basis:** Behaviorism.

### 2. Inquiry-Based Learning Model

- **Description:** Student-centered model where students explore questions, problems, or scenarios rather than receiving direct instruction. It encourages critical thinking and problem-solving.
- **Process:**
  - Pose questions or problems.
  - Research and gather information.
  - Analyze findings and draw conclusions.
  - Present and discuss results.
- **Best For:** Science, social studies, and subjects that benefit from exploration and discovery.
- **Theoretical Basis:** Constructivism.

### 3. Cooperative Learning Model

- **Description:** Students work together in small groups to achieve a common goal. Learning is viewed as a social process where students learn from one another.
- **Process:**
  - Form small, diverse groups.
  - Assign specific roles and tasks to each member.

**CHAPTER 3**  
**Activity-Based and Group Controlled Instruction**  
**Prof. T. SELVARAJ**

**Assistant professor, School of Education,  
PRIST Deemed to Be University, Thanjavur.**

**Activity-Based Learning (ABL)** and **Group Controlled Instruction** are teaching methods that prioritize active student engagement and collaboration. They focus on learning by doing, rather than passive reception of knowledge, and are particularly effective in fostering critical thinking, teamwork, and practical problem-solving skills.

### **1. Activity-Based Learning (ABL)**

**Definition:** Activity-Based Learning emphasizes learning through hands-on activities and real-world experiences. It shifts the focus from passive learning (e.g., lectures) to student-centered activities that require exploration, interaction, and application of knowledge.

#### **Key Features:**

- **Student-Centered:** Students take an active role in their learning through participation in activities.
- **Experiential Learning:** Activities are often based on real-life situations, fostering practical understanding.
- **Inquiry and Exploration:** Encourages students to ask questions, investigate, and find solutions on their own.
- **Variety of Activities:** Includes experiments, role-playing, simulations, games, field trips, and creative projects.
- **Skills Focus:** Promotes the development of soft skills (e.g., communication, collaboration) alongside academic skills.

#### **Process:**

1. **Introduction of Concepts:** Brief introduction of the topic or concept by the teacher.
2. **Activity Implementation:** Students engage in hands-on tasks designed to explore or apply the concept.
3. **Exploration and Discovery:** Through the activity, students make observations, gather data, or create a product.
4. **Discussion and Reflection:** Students share their findings or experiences, reflecting on what they learned.
5. **Evaluation and Feedback:** The teacher assesses the students' performance, provides feedback, and clarifies any misunderstandings.

#### **Benefits:**

- Enhances critical thinking, creativity, and problem-solving.
- Increases student engagement and motivation.

## CHAPTER 4

### Resource - Based Learning

**DR. R. GUNASEKARAN**

Assistant professor, School of Education,  
PRIST Deemed to Be University, Thanjavur.

**Resource-Based Learning (RBL)** is an educational approach that emphasizes the use of various resources—such as texts, videos, websites, and hands-on materials—to facilitate learning. It encourages students to engage actively with information, develop research skills, and become independent learners. In the context of biological science, RBL can enhance understanding and application of concepts by allowing students to explore diverse resources and perspectives.

#### Key Characteristics of Resource-Based Learning

1. **Diverse Resources:** Utilizes a wide range of materials, including books, scientific articles, online databases, videos, models, and lab equipment. This variety helps cater to different learning styles and preferences.
2. **Student-Centered:** Places students at the center of the learning process. They take responsibility for their own learning by selecting resources that interest them and align with their learning objectives.
3. **Inquiry and Exploration:** Encourages students to ask questions, investigate topics, and engage in critical thinking. This exploration can lead to deeper understanding and retention of knowledge.
4. **Collaboration:** Often involves collaborative projects where students work in groups, sharing resources and ideas, which fosters teamwork and communication skills.
5. **Integration of Technology:** Frequently incorporates digital tools and resources, allowing access to a vast amount of information and interactive learning opportunities.

#### Steps in Implementing Resource-Based Learning

1. **Identify Learning Objectives:** Clearly define what students should learn or accomplish through the RBL process.
2. **Select Appropriate Resources:** Curate a range of resources relevant to the topic. This may include textbooks, scientific journals, online articles, multimedia presentations, and laboratory equipment.
3. **Design Activities:** Create engaging activities that guide students in using the resources. Activities can include research projects, presentations, experiments, or group discussions.
4. **Facilitate Learning:** Act as a guide and facilitator, helping students navigate resources, encouraging inquiry, and providing support as needed.
5. **Encourage Reflection:** Have students reflect on their learning process, the resources they used, and how they applied their findings to the topic.
6. **Assess Learning:** Evaluate student understanding and skills through various assessment methods, such as presentations, reports, or practical demonstrations.

**CHAPTER 5**  
**Assessment in Pedagogy of Mathematics**  
**Prof. T. SELVARAJ**  
**Assistant professor, School of Education,**  
**PRIST Deemed to Be University, Thanjavur.**

Assessment in the pedagogy of mathematics is essential for evaluating student understanding, guiding instruction, and promoting learning. Here are key aspects to consider:

**1. Types of Assessment**

- **Formative Assessment:** Ongoing assessments, such as quizzes, homework, and class discussions, help monitor student progress and understanding in real-time.
- **Summative Assessment:** End-of-unit tests or standardized exams measure cumulative knowledge and understanding of mathematical concepts.

**2. Diagnostic Assessment**

- Conducting initial assessments helps identify students' prior knowledge and areas that need reinforcement before instruction begins.

**3. Performance-Based Assessment**

- Tasks that require students to apply their mathematical knowledge to solve real-world problems or complete projects can demonstrate deeper understanding.

**4. Use of Technology**

- Online quizzes and interactive platforms (like Kahoot or Google Forms) can provide immediate feedback and engage students in their learning.

**5. Peer and Self-Assessment**

- Encouraging students to evaluate their own work and that of their peer's fosters reflection and critical thinking skills.

**6. Diverse Formats**

- Incorporating a variety of assessment formats—such as written tests, oral presentations, and hands-on activities—can cater to different learning styles and strengths.

**7. Feedback Mechanisms**

- Providing constructive feedback helps students understand their mistakes and learn from them, promoting growth and improvement.

## CHAPTER 6

### Aids for Teaching Mathematics

DR. R. GUNASEKARAN

Assistant professor, School of Education,  
PRIST Deemed to Be University, Thanjavur.

Teaching mathematics effectively often involves using a variety of aids and tools to enhance understanding and engagement. Here are some helpful aids:

1. **Visual Aids:**

- **Charts and Graphs:** Help illustrate data and mathematical concepts.
- **Manipulatives:** Objects like blocks, counters, or geometric shapes to explore concepts hands-on.

2. **Technology:**

- **Interactive Software:** Programs like GeoGebra or Desmos for graphing and visualizing functions.
- **Online Resources:** Websites with math games, quizzes, and instructional videos (e.g., Khan Academy).

3. **Worksheets and Handouts:**

- Provide structured practice and reinforce concepts learned in class.

4. **Games and Puzzles:**

- Math games that make learning fun and encourage problem-solving skills.

5. **Storytelling:**

- Incorporating narratives to explain concepts, making math relatable.

6. **Real-World Applications:**

- Examples that connect math to everyday life, such as budgeting or cooking.

7. **Group Work and Collaboration:**

- Encouraging students to work together on problems to promote discussion and deeper understanding.

8. **Assessment Tools:**

- Quizzes and formative assessments to gauge understanding and guide instruction.

## CHAPTER 7

### Evaluation

**DR. R. GUNASEKARAN**  
Assistant professor, School of Education,  
PRIST Deemed to Be University, Thanjavur.

**Evaluation** in the context of education refers to the systematic process of assessing the effectiveness of teaching, learning, and educational strategies. It involves gathering and analyzing data to determine how well students are learning, how effectively instructional methods are working, and how educational objectives are being met. In the pedagogy of biological science, evaluation helps educators refine their teaching practices, assess student progress, and improve the curriculum.

### Types of Evaluation in Education

#### 1. Formative Evaluation

- **Definition:** Ongoing evaluations conducted during the teaching-learning process.
- **Purpose:** To monitor student learning and provide feedback that can be used to improve instruction and learning in real-time.
- **Examples:**
  - Classroom quizzes
  - Group discussions
  - Short feedback forms
  - Student reflections
- **Benefits:** Helps teachers adjust their teaching methods, address student misconceptions early, and guide students toward achieving learning goals.

#### 2. Summative Evaluation

- **Definition:** Evaluation conducted at the end of a unit, course, or program to assess the overall effectiveness and achievement.
- **Purpose:** To evaluate student learning at the conclusion of an instructional period and to determine if the learning objectives were met.
- **Examples:**
  - Final exams
  - End-of-term projects
  - Standardized tests
  - Cumulative reports
- **Benefits:** Provides a comprehensive measure of student performance and curriculum effectiveness. Summative evaluations often inform grades and certifications.

#### 3. Diagnostic Evaluation

- **Definition:** Pre-assessment conducted before instruction begins to understand students' prior knowledge and identify learning needs.
- **Purpose:** To identify strengths, weaknesses, and areas for improvement before the learning process starts.



## CHAPTER 8

### Planning for Instruction

Prof. T. SELVARAJ

Assistant professor, School of Education,  
PRIST Deemed to Be University, Thanjavur.

**Planning for instruction** is a vital component of effective teaching, as it involves organizing and designing lessons to meet learning objectives, address student needs, and ensure that the content is delivered effectively. In the context of biological science, instructional planning focuses on how to best teach scientific concepts, theories, and skills, ensuring that students can not only understand the material but also apply it to real-world scenarios.

#### Key Steps in Planning for Instruction

##### 1. Define Learning Objectives

- **Purpose:** Clear learning objectives outline what students should know, understand, and be able to do by the end of the lesson or unit.
- **Examples:**
  - "Students will be able to explain the process of photosynthesis."
  - "Students will analyze the role of natural selection in evolution."
- **SMART Criteria:** Learning objectives should be **S**pecific, **M**easurable, **A**chievable, **R**elevant, and **T**ime-bound to ensure clarity and focus.

##### 2. Identify and Align Curriculum Standards

- **Purpose:** Instruction must align with national, state, or local curriculum standards to ensure consistency and comprehensiveness.
- **Examples:** For biology, this may include standards related to genetics, ecosystems, evolution, and cell biology.
- **Benefits:** Ensures that instruction covers essential content and skills, helping students meet academic expectations.

##### 3. Understand Student Needs and Context

- **Purpose:** Tailoring instruction to meet the diverse needs of learners.
- **Considerations:**
  - **Learning styles:** Some students may be visual learners, while others prefer hands-on activities or verbal instruction.
  - **Prior knowledge:** Assessing what students already know helps guide the depth of instruction.
  - **Diverse learning needs:** Differentiating instruction for students with special needs, language barriers, or advanced abilities is essential.
- **Examples:** Using models and diagrams for visual learners, or incorporating group activities for kinesthetic learners.

##### 4. Select and Organize Content

- **Purpose:** Identify the key concepts, facts, and skills to be taught and decide the sequence in which they will be presented.
- **Examples:**
  - Teaching cellular biology before diving into genetics, as students need to understand cell structures and functions before learning about DNA.

## CHAPTER 9

### Models

Prof. R. VAISHNAVI

Assistant professor, School of Education,  
PRIST Deemed to Be University, Thanjavur.

**Models of teaching** refer to structured, systematic approaches to instruction that help guide the teaching process to achieve specific learning outcomes. These models are based on theories of learning and development and provide educators with frameworks for organizing and delivering content, fostering student engagement, and promoting the effective acquisition of knowledge and skills. Each model emphasizes different aspects of learning and teaching, and the choice of model depends on the subject matter, learning objectives, and the needs of the students.

Here are some of the most widely recognized models of teaching:

#### 1. The Direct Instruction Model

- **Definition:** A teacher-centered approach that emphasizes clear, structured, and explicit teaching of content or skills.
- **Key Features:**
  - Focus on mastery of content through systematic instruction.
  - The teacher leads the lesson by providing information, modeling, and giving guided practice.
  - Frequent feedback and correction are given to ensure understanding.
  - Lesson phases: Introduction, Presentation, Guided Practice, Independent Practice, and Closure.
- **Advantages:**
  - Highly effective for teaching foundational skills, especially in areas like math, reading, or basic biology concepts.
  - Structured and efficient, which makes it ideal for covering large amounts of content.
- **Disadvantages:**
  - Less emphasis on critical thinking and creativity.
  - Limits student autonomy and may not engage all learners.

**Example in Biology:** Teaching the structure of the cell by explaining and modeling the parts, providing guided practice through labeling exercises, and then assigning independent activities like cell diagram creation.

#### 2. The Inquiry-Based Learning Model

- **Definition:** A student-centered approach that encourages students to ask questions, investigate problems, and discover answers through exploration.
- **Key Features:**
  - Students are active participants in the learning process, conducting experiments, investigations, or research.

## CHAPTER 10

**The Mathematics Teacher**  
**Prof. T. SELVARAJ**  
**Assistant professor, School of Education,**  
**PRIST Deemed to Be University, Thanjavur.**

"The Mathematics Teacher" is a well-respected journal published by the National Council of Teachers of Mathematics (NCTM). It focuses on innovative practices, research, and insights related to teaching mathematics at various educational levels.

Key features often include:

1. **Research Articles:** Presenting findings from studies in math education.
2. **Teaching Strategies:** Practical tips and techniques for effective classroom instruction.
3. **Curriculum Development:** Discussions on designing and implementing math curricula.
4. **Technology Integration:** Exploring the role of technology in teaching and learning math.
5. **Professional Development:** Resources and ideas for teachers to enhance their skills.

This journal serves as a valuable resource for educators looking to improve their teaching methods and stay current with trends in mathematics education. Are you looking for specific topics or articles related to "The Mathematics Teacher"?

### Key Responsibilities

1. **Curriculum Development**
  - Design and implement a curriculum that aligns with educational standards and industry trends, covering topics such as programming languages, algorithms, data structures, software development, and cybersecurity.
2. **Instructional Delivery**
  - Use a variety of teaching methods, including lectures, hands-on projects, and collaborative learning, to engage students with different learning styles.
  - Integrate technology into lessons, using tools such as IDEs, simulation software, and online resources to enhance learning.
3. **Assessment and Evaluation**
  - Create and administer assessments (quizzes, exams, projects) to evaluate student understanding and skills, providing constructive feedback to support improvement.
  - Use formative assessments to monitor progress and adjust instruction as needed.
4. **Facilitating Practical Experience**
  - Guide students through practical coding exercises, projects, and labs that allow them to apply theoretical concepts in real-world scenarios.
  - Encourage participation in coding competitions, hackathons, and collaborative projects to foster teamwork and problem-solving skills.
5. **Promoting Computational Thinking**
  - Teach students to approach problems methodically, breaking them down into smaller, manageable parts and using algorithms to devise solutions.



# **PEDAGOGY OF ENGLISH: PART - II**

Edited by

**DR.T.S.PARVATHY**

---



978-93-6255-842-8

Pedagogy of English: Part - II

Copyright ©2018-2019 by Dr. T.S. Parvathy

All rights reserved. No part of this book may be reproduced or transmitted in any form or by any means without written permission from the author.

ISBN:978-93-6255-842-8

Publisher: Ponnaiyah Ramajayam Institute of Science and Technology (PRIST)

## TABLE OF CONTENTS

Introduction .....	5
CHAPTER 1 Pedagogical Analysis .....	15
Dr. R. GUNASEKARAN	
CHAPTER 2 Teaching Models .....	27
Prof. T. SUBHASHINI	
CHAPTER 3 Activity-Based and Group Controlled Instruction .....	45
Prof. R. VAISHNAVI	
CHAPTER 4 Resources-Based Learning .....	68
Prof. T. SELVARAJ	
CHAPTER 5 Assessment in Pedagogy of English .....	80
Dr. T.S. PARVATHY	
CHAPTER 6 Aids for Teaching English .....	95
Dr. R. GUNASEKARAN	
CHAPTER 7 Evaluation .....	126
Dr. R. GUNASEKARAN	
CHAPTER 8 Planning for Instruction .....	135
Prof. T. SELVARAJ	
CHAPTER 9 Models .....	155
Prof. R. VAISHNAVI	
CHAPTER 10 The English Teacher .....	162
Prof. T. SUBHASHINI	
REFERENCES.....	172

## **CHAPTER I** **Pedagogical Analysis**

**DR. R. GUNASEKARAN**

Assistant Professor, School of Education, PRIST Deemed to be University, Thanjavur

**A pedagogical analysis** involves the detailed examination of teaching methods, learning activities, and educational processes. This type of analysis focuses on understanding how educational goals are achieved and how learning experiences are designed, implemented, and evaluated. It's essential for improving teaching strategies, developing curriculum, and enhancing student learning outcomes.

### **Key Components of Pedagogical Analysis:**

1. **Learning Objectives:**
  - Analysis begins with identifying clear learning goals.
  - Are the objectives aligned with the needs of the students and the subject matter?
2. **Teaching Methods:**
  - What teaching approaches are being used (e.g., lecture, discussion, problem-solving, hands-on activities)?
  - Are these methods effective for the intended learning outcomes?
3. **Learning Theories:**
  - Which learning theories (e.g., behaviorism, constructivism, cognitivism) underpin the pedagogical approach?
  - Are these theories applied in a way that supports diverse learners?
4. **Content Structure and Delivery:**
  - Is the curriculum content organized in a logical, accessible way?
  - How is the content delivered—through direct instruction, multimedia, collaborative activities, etc.?
5. **Assessment and Evaluation:**
  - Are the assessment tools (quizzes, exams, projects) aligned with the learning objectives?
  - Is there a balance between formative (ongoing) and summative (final) assessments?
6. **Learner Engagement:**
  - How does the teaching approach engage students?
  - Are interactive or experiential learning opportunities provided?
7. **Student-Centeredness:**
  - Is the pedagogy flexible and adaptable to meet the individual needs of students?
  - Does it account for varying learning styles, backgrounds, and abilities?
8. **Technological Integration:**
  - How is technology being used to support learning?
  - Are online tools or digital resources appropriately incorporated?
9. **Classroom Environment:**
  - How conducive is the learning environment to fostering active participation?

## CHAPTER 2 Teaching Models

**Prof. T. SUBHASHINI**

Assistant Professor, School of Education, PRIST Deemed to be University, Thanjavur

**Teaching models** are structured frameworks or strategies used by educators to deliver instruction in a way that promotes learning and helps achieve educational goals. These models often align with specific pedagogical theories and approaches. Below are some widely recognized teaching models:

### 1. Direct Instruction Model

- **Description:** Teacher-centered, structured, and systematic approach where the teacher leads the class through explicit teaching, often in a step-by-step process.
- **Process:**
  - Introduction and review of prior learning.
  - Presentation of new material through lectures or demonstrations.
  - Guided practice with feedback.
  - Independent practice.
  - Assessment.
- **Best For:** Subjects that require rote memorization, skill-building, and learning foundational concepts (e.g., math, grammar).
- **Theoretical Basis:** Behaviorism.

### 2. Inquiry-Based Learning Model

- **Description:** Student-centered model where students explore questions, problems, or scenarios rather than receiving direct instruction. It encourages critical thinking and problem-solving.
- **Process:**
  - Pose questions or problems.
  - Research and gather information.
  - Analyze findings and draw conclusions.
  - Present and discuss results.
- **Best For:** Science, social studies, and subjects that benefit from exploration and discovery.
- **Theoretical Basis:** Constructivism.

### 3. Cooperative Learning Model

- **Description:** Students work together in small groups to achieve a common goal. Learning is viewed as a social process where students learn from one another.
- **Process:**
  - Form small, diverse groups.
  - Assign specific roles and tasks to each member.



## CHAPTER 3 Activity-Based and Group Controlled Instruction

**Prof. R. VAISHNAVI**

Assistant Professor, School of Education, PRIST Deemed to be University, Thanjavur

**Activity-Based Learning (ABL)** and **Group Controlled Instruction** are teaching methods that prioritize active student engagement and collaboration. They focus on learning by doing, rather than passive reception of knowledge, and are particularly effective in fostering critical thinking, teamwork, and practical problem-solving skills.

### 1. Activity-Based Learning (ABL)

**Definition:** Activity-Based Learning emphasizes learning through hands-on activities and real-world experiences. It shifts the focus from passive learning (e.g., lectures) to student-centered activities that require exploration, interaction, and application of knowledge.

#### Key Features:

- **Student-Centered:** Students take an active role in their learning through participation in activities.
- **Experiential Learning:** Activities are often based on real-life situations, fostering practical understanding.
- **Inquiry and Exploration:** Encourages students to ask questions, investigate, and find solutions on their own.
- **Variety of Activities:** Includes experiments, role-playing, simulations, games, field trips, and creative projects.
- **Skills Focus:** Promotes the development of soft skills (e.g., communication, collaboration) alongside academic skills.

#### Process:

1. **Introduction of Concepts:** Brief introduction of the topic or concept by the teacher.
2. **Activity Implementation:** Students engage in hands-on tasks designed to explore or apply the concept.
3. **Exploration and Discovery:** Through the activity, students make observations, gather data, or create a product.
4. **Discussion and Reflection:** Students share their findings or experiences, reflecting on what they learned.
5. **Evaluation and Feedback:** The teacher assesses the students' performance, provides feedback, and clarifies any misunderstandings.

#### Benefits:

- Enhances critical thinking, creativity, and problem-solving.
- Increases student engagement and motivation.

**CHAPTER 4**  
**Resources-Based Learning**  
**Prof. T. SELVARAJ**

Assistant Professor, School of Education, PRIST Deemed to be University, Thanjavur

**Resource-Based Learning (RBL)** is an educational approach that emphasizes the use of various resources—such as texts, videos, websites, and hands-on materials—to facilitate learning. It encourages students to engage actively with information, develop research skills, and become independent learners. In the context of biological science, RBL can enhance understanding and application of concepts by allowing students to explore diverse resources and perspectives.

**Key Characteristics of Resource-Based Learning**

1. **Diverse Resources:** Utilizes a wide range of materials, including books, scientific articles, online databases, videos, models, and lab equipment. This variety helps cater to different learning styles and preferences.
2. **Student-Centered:** Places students at the center of the learning process. They take responsibility for their own learning by selecting resources that interest them and align with their learning objectives.
3. **Inquiry and Exploration:** Encourages students to ask questions, investigate topics, and engage in critical thinking. This exploration can lead to deeper understanding and retention of knowledge.
4. **Collaboration:** Often involves collaborative projects where students work in groups, sharing resources and ideas, which fosters teamwork and communication skills.
5. **Integration of Technology:** Frequently incorporates digital tools and resources, allowing access to a vast amount of information and interactive learning opportunities.

**Steps in Implementing Resource-Based Learning**

1. **Identify Learning Objectives:** Clearly define what students should learn or accomplish through the RBL process.
2. **Select Appropriate Resources:** Curate a range of resources relevant to the topic. This may include textbooks, scientific journals, online articles, multimedia presentations, and laboratory equipment.
3. **Design Activities:** Create engaging activities that guide students in using the resources. Activities can include research projects, presentations, experiments, or group discussions.
4. **Facilitate Learning:** Act as a guide and facilitator, helping students navigate resources, encouraging inquiry, and providing support as needed.
5. **Encourage Reflection:** Have students reflect on their learning process, the resources they used, and how they applied their findings to the topic.
6. **Assess Learning:** Evaluate student understanding and skills through various assessment methods, such as presentations, reports, or practical demonstrations.

## CHAPTER 5 Assessment in Pedagogy of English

**Dr. T.S. PARVATHY**

Assistant Professor, School of Education, PRIST Deemed to be University, Thanjavur

Assessment in the **Pedagogy of English** plays a critical role in determining how well students are mastering the language skills (reading, writing, speaking, and listening), as well as understanding literature. It also helps guide instruction, providing feedback to both teachers and students to improve learning outcomes. There are various forms of assessments that English teachers can use to evaluate student progress.

### 1. Types of Assessment

#### *A. Formative Assessment*

- **Purpose:** To monitor student learning and provide ongoing feedback that can be used by teachers to improve their teaching and by students to improve their learning.
- **Examples:**
  - **Classroom discussions:** Observing students' participation and understanding during discussions.
  - **Quizzes:** Short, low-stakes quizzes to check comprehension of grammar rules or literary concepts.
  - **Exit slips:** Short responses at the end of a lesson to gauge what students have understood.
  - **Peer reviews:** Students assess each other's writing or speaking to encourage reflection and critical thinking.
- **Advantages:** Helps identify gaps in knowledge during the learning process, allowing immediate intervention.

#### *B. Summative Assessment*

- **Purpose:** To evaluate student learning at the end of an instructional unit by comparing it against a standard or benchmark.
- **Examples:**
  - **Final exams:** Testing a student's overall understanding of language skills or literary content.
  - **End-of-term essays:** Assessing analytical and writing skills through structured essays.
  - **Standardized tests:** National or state-level assessments of English proficiency.
  - **Oral presentations:** Students demonstrate their ability to communicate ideas in spoken English.
- **Advantages:** Provides a clear indication of overall achievement, useful for final grades.
- **Purpose:** To identify students' existing knowledge, skills, and abilities before instruction begins. This is especially useful in understanding individual needs in English language learning.

## CHAPTER 6

### Aids for Teaching English

DR. R. GUNASEKARAN

Assistant Professor, School of Education, PRIST Deemed to be University, Thanjavur

#### Visual Aids

**Flashcards:** Useful for vocabulary, grammar rules, or idioms.

- **Posters and Charts:** Display grammar rules, tenses, or word families for constant reference.
- **Infographics:** Provide visual representation of language structures, storytelling elements, or vocabulary sets.
- **Videos and Animations:** Use language learning apps or platforms like YouTube for video content that teaches through storytelling or conversations.

#### 2. Interactive Tools

- **Language Learning Apps:** Tools like Duolingo or Memrise are engaging for students to practice vocabulary and grammar.
- **Smartboard Activities:** Engage students in interactive grammar and vocabulary exercises, games, and quizzes.
- **Online Games:** Platforms like Kahoot! or Quizlet Live allow students to practice English in a fun, competitive way.

#### 3. Technology Integration

- **Listening Tools:** Podcasts or audio lessons improve listening skills. TED Talks, audiobooks, or specific English-learning podcasts can also be effective.
- **Online Quizzes:** Tools like Google Forms or Quizizz for testing reading comprehension, grammar, or vocabulary.
- **Virtual Reality (VR):** For more immersive language learning experiences, VR tools provide interactive environments to practice conversations.

#### 4. Reading Aids

- **Graded Readers:** Books specifically written for learners at different English proficiency levels.
- **E-books with built-in dictionaries:** E-readers or apps that allow students to instantly look up words.
- **Comics and Graphic Novels:** Visual storytelling enhances comprehension and engages reluctant readers.

#### 5. Writing Aids.

## CHAPTER 7

### Evaluation

**DR. R. GUNASEKARAN**

Assistant Professor, School of Education, PRIST Deemed to be University, Thanjavur

**Evaluation** in the context of education refers to the systematic process of assessing the effectiveness of teaching, learning, and educational strategies. It involves gathering and analyzing data to determine how well students are learning, how effectively instructional methods are working, and how educational objectives are being met. In the pedagogy of biological science, evaluation helps educators refine their teaching practices, assess student progress, and improve the curriculum.

### Types of Evaluation in Education

#### 1. Formative Evaluation

- **Definition:** Ongoing evaluations conducted during the teaching-learning process.
- **Purpose:** To monitor student learning and provide feedback that can be used to improve instruction and learning in real-time.
- **Examples:**
  - Classroom quizzes
  - Group discussions
  - Short feedback forms
  - Student reflections
- **Benefits:** Helps teachers adjust their teaching methods, address student misconceptions early, and guide students toward achieving learning goals.

#### 2. Summative Evaluation

- **Definition:** Evaluation conducted at the end of a unit, course, or program to assess the overall effectiveness and achievement.
- **Purpose:** To evaluate student learning at the conclusion of an instructional period and to determine if the learning objectives were met.
- **Examples:**
  - Final exams
  - End-of-term projects
  - Standardized tests
  - Cumulative reports
- **Benefits:** Provides a comprehensive measure of student performance and curriculum effectiveness. Summative evaluations often inform grades and certifications.

#### 3. Diagnostic Evaluation

- **Definition:** Pre-assessment conducted before instruction begins to understand students' prior knowledge and identify learning needs.
- **Purpose:** To identify strengths, weaknesses, and areas for improvement before the learning process starts.

## CHAPTER 8

### Planning for Instruction

Prof. T. SELVARAJ

Assistant Professor, School of Education, PRIST Deemed to be University, Thanjavur

**Planning for instruction** is a vital component of effective teaching, as it involves organizing and designing lessons to meet learning objectives, address student needs, and ensure that the content is delivered effectively. In the context of biological science, instructional planning focuses on how to best teach scientific concepts, theories, and skills, ensuring that students can not only understand the material but also apply it to real-world scenarios.

#### Key Steps in Planning for Instruction

##### 1. Define Learning Objectives

- **Purpose:** Clear learning objectives outline what students should know, understand, and be able to do by the end of the lesson or unit.
- **Examples:**
  - "Students will be able to explain the process of photosynthesis."
  - "Students will analyze the role of natural selection in evolution."
- **SMART Criteria:** Learning objectives should be **S**pecific, **M**easurable, **A**chievable, **R**elevant, and **T**ime-bound to ensure clarity and focus.

##### 2. Identify and Align Curriculum Standards

- **Purpose:** Instruction must align with national, state, or local curriculum standards to ensure consistency and comprehensiveness.
- **Examples:** For biology, this may include standards related to genetics, ecosystems, evolution, and cell biology.
- **Benefits:** Ensures that instruction covers essential content and skills, helping students meet academic expectations.

##### 3. Understand Student Needs and Context

- **Purpose:** Tailoring instruction to meet the diverse needs of learners.
- **Considerations:**
  - **Learning styles:** Some students may be visual learners, while others prefer hands-on activities or verbal instruction.
  - **Prior knowledge:** Assessing what students already know helps guide the depth of instruction.
  - **Diverse learning needs:** Differentiating instruction for students with special needs, language barriers, or advanced abilities is essential.
- **Examples:** Using models and diagrams for visual learners, or incorporating group activities for kinesthetic learners.

##### 4. Select and Organize Content

- **Purpose:** Identify the key concepts, facts, and skills to be taught and decide the sequence in which they will be presented.
- **Examples:**
  - Teaching cellular biology before diving into genetics, as students need to understand cell structures and functions before learning about DNA.

## CHAPTER 9

### Models

Prof. R. VAISHNAVI

Assistant Professor, School of Education, PRIST Deemed to be University, Thanjavur

**Models of teaching** refer to structured, systematic approaches to instruction that help guide the teaching process to achieve specific learning outcomes. These models are based on theories of learning and development and provide educators with frameworks for organizing and delivering content, fostering student engagement, and promoting the effective acquisition of knowledge and skills. Each model emphasizes different aspects of learning and teaching, and the choice of model depends on the subject matter, learning objectives, and the needs of the students.

Here are some of the most widely recognized models of teaching:

#### 1. The Direct Instruction Model

- **Definition:** A teacher-centered approach that emphasizes clear, structured, and explicit teaching of content or skills.
- **Key Features:**
  - Focus on mastery of content through systematic instruction.
  - The teacher leads the lesson by providing information, modeling, and giving guided practice.
  - Frequent feedback and correction are given to ensure understanding.
  - Lesson phases: Introduction, Presentation, Guided Practice, Independent Practice, and Closure.
- **Advantages:**
  - Highly effective for teaching foundational skills, especially in areas like math, reading, or basic biology concepts.
  - Structured and efficient, which makes it ideal for covering large amounts of content.
- **Disadvantages:**
  - Less emphasis on critical thinking and creativity.
  - Limits student autonomy and may not engage all learners.

**Example in Biology:** Teaching the structure of the cell by explaining and modeling the parts, providing guided practice through labeling exercises, and then assigning independent activities like cell diagram creation.

#### 2. The Inquiry-Based Learning Model

- **Definition:** A student-centered approach that encourages students to ask questions, investigate problems, and discover answers through exploration.
- **Key Features:**
  - Students are active participants in the learning process, conducting experiments, investigations, or research..

## CHAPTER 10

### The English Teacher

Prof. T. SUBHASHINI

Assistant Professor, School of Education, PRIST Deemed to be University, Thanjavur

**The English Teacher** refers to a professional whose primary role is to teach English language and literature to students. They play a pivotal role in developing students' reading, writing, speaking, and listening skills, as well as fostering an appreciation for literature and critical thinking.

Below are key aspects of the role of an English teacher:

#### 1. Role and Responsibilities

- **Teaching Language Skills:** English teachers focus on teaching the core language skills: reading, writing, listening, and speaking. They also teach grammar, vocabulary, and pronunciation.
- **Literature Instruction:** They introduce students to various literary genres, including poetry, drama, short stories, and novels, fostering analytical thinking and interpretive skills.
- **Assessment:** Regularly assess student progress through essays, tests, projects, and presentations to evaluate understanding and improvement.
- **Encouraging Critical Thinking:** English teachers encourage students to analyze texts, understand themes, question assumptions, and form independent opinions about what they read or hear.
- **Cultural Awareness:** Through literature and language, English teachers expose students to diverse cultures, perspectives, and ideas, helping them understand global contexts.
- **Classroom Management:** Like all educators, English teachers must manage student behavior, promote a positive classroom environment, and maintain discipline while ensuring that learning objectives are met.
- **Curriculum Design:** Some English teachers may be involved in designing or modifying the English curriculum to better meet student needs or align with new standards.

#### 2. Qualities of an Effective English Teacher

- **Strong Communication Skills:** Clear and articulate communication is crucial for teaching language effectively.
- **Passion for Literature and Language:** A love for reading and an appreciation for language help to inspire students to engage with the subject.
- **Patience and Empathy:** Teaching language can be challenging, especially with students who struggle with reading or writing. A good English teacher must be patient and empathetic to different learning paces.
- **Creativity:** English teachers often have to find creative ways to present material, especially when dealing with complex literary concepts or abstract language skills.



# TEACHING AND LEARNING

EDITED BY

**T.SELVARAJ**



978-93-6255-457-4

Teaching and Learning

Copyright ©2020-2021 by Prof. T. Selvaraj

All rights reserved. No part of this book may be reproduced or transmitted in any form or by any means without written permission from the author.

ISBN:978-93-6255-457-4

Publisher: Ponnaiyah Ramajayam Institute of Science and Technology (PRIST)

## TABLE OF CONTENTS

Introduction .....	5
CHAPTER 1 Nature of learning and Teaching .....	15
Prof. T. SUBHASHINI	
CHAPTER 2 Teaching in Diverse Classrooms and Learning in and out of school.....	26
DR. R. GUNASEKARAN	
CHAPTER 3 Theory of Constructivism and Learner Centered Teaching.....	47
Prof. T. SELVARAJ	
CHAPTER 4 Models of teaching .....	68
DR. R. GUNASEKARAN	
CHAPTER 5 Teaching as a Profession .....	85
Prof. R. VAISHNAVI	
CHAPTER 6 Techniques of active learning.....	107
Prof. T. SUBHASHINI	
CHAPTER 7 Classroom – Diversity in the classroom .....	123
DR. R. GUNASEKARAN	
CHAPTER 8 learning Process.....	137
Prof. T. SELVARAJ	
CHAPTER 9 Psychology Models.....	151
Prof. R. VAISHNAVI	
CHAPTER 10 Teacher Professional Ethics .....	163
Prof. T. SUBHASHINI	
REFERENCES.....	171

**CHAPTER 1**  
**Nature of learning and Teaching**  
**Prof. T. SUBHASHINI**  
**Assistant professor, School of Education,**  
**PRIST Deemed to Be University, Thanjavur.**

**Nature of Learning and Teaching:**

The nature of learning and teaching is dynamic, interdependent, and shaped by several factors, including cognitive processes, social interactions, and cultural contexts. It involves a complex relationship between the learner, the teacher, the content being learned, and the methods used to facilitate understanding. Below is an exploration of the essential characteristics of learning and teaching:

**1. Nature of Learning:**

Learning is a **continuous, active, and transformative** process that involves acquiring new knowledge, skills, attitudes, and values. It is multifaceted and influenced by various factors such as motivation, prior knowledge, environment, and individual differences. Here are some key characteristics:

**A. Active Process:**

- **Learning is Constructive:** Learners actively engage with new information by linking it to their existing knowledge, experiences, and mental frameworks. This is rooted in constructivist theories (e.g., Piaget, Vygotsky), which emphasize that learners are not passive recipients of information but active participants in building their understanding.
- **Hands-On Engagement:** Learning is often more effective when students are involved in hands-on or experiential activities. Real-life tasks, experiments, or role-plays can deepen understanding and retention.

**B. Lifelong and Adaptive:**

- **Ongoing Development:** Learning is not confined to formal education. It continues throughout life as people adapt to new experiences, environments, and roles. This lifelong process involves acquiring new knowledge or modifying existing knowledge based on changing circumstances.
- **Learning to Learn:** Metacognition, or thinking about one's own learning, is a critical aspect of being a lifelong learner. The ability to reflect on and control one's own learning process is essential for adaptability.

**C. Individualized and Differentiated:**

- **Learning Styles and Preferences:** People learn in different ways, and these differences should be acknowledged. Some may prefer visual learning, others auditory, and still

## CHAPTER 2 Teaching in Diverse Classrooms and Learning in and out of school

**DR. R. GUNASEKARAN**  
Assistant professor, School of Education,  
PRIST Deemed to Be University, Thanjavur.

### Teaching in Diverse Classrooms and Learning In and Out of School

Teaching in diverse classrooms and facilitating learning both inside and outside of school requires educators to be flexible, culturally responsive, and aware of the varied backgrounds, experiences, and learning styles of their students. Diversity in the classroom includes differences in culture, language, socioeconomic background, learning abilities, and more. Moreover, learning doesn't stop at the classroom door—students gain valuable knowledge from out-of-school experiences, including their communities, homes, and extracurricular activities. Below is a comprehensive discussion on teaching in diverse classrooms and learning both in and out of school.

#### 1. Teaching in Diverse Classrooms

Diversity in classrooms is an asset, but it also brings unique challenges. Teachers must adapt their methods, materials, and expectations to meet the varied needs of their students. Below are key principles and strategies for teaching in diverse classrooms:

##### A. Culturally Responsive Teaching (CRT)

- **Recognizing Cultural Diversity:** Culturally responsive teaching acknowledges and incorporates students' cultural backgrounds and experiences into the learning process. This promotes inclusion and helps students connect the curriculum to their own lives.
- **Culturally Relevant Materials:** Teachers should use materials (texts, media, examples) that reflect diverse cultures, perspectives, and histories. This includes celebrating the achievements and histories of all racial, ethnic, and cultural groups.
- **Building on Prior Knowledge:** Students come to the classroom with different backgrounds and knowledge bases. Teachers should build on this prior knowledge and use it as a foundation for introducing new concepts.

##### B. Differentiated Instruction

- **Varying Instructional Methods:** Since students have diverse learning styles (visual, auditory, kinesthetic), teachers should use a mix of instructional methods, such as visual aids, group work, hands-on activities, and discussions to meet the learning needs of all students.
- **Flexible Grouping:** Grouping students based on their needs and abilities for certain activities, and regularly changing these groups, ensures that all students have opportunities to collaborate and learn from peers.
- **Tiered Assignments**

## CHAPTER 3 Theory of Constructivism and Learner Centered Teaching

**Prof. T. SELVARAJ**  
Assistant professor, School of Education,  
PRIST Deemed to Be University, Thanjavur.

### Theory of Constructivism and Learner-Centered Teaching

Constructivism is a learning theory that emphasizes the active role of learners in constructing their own understanding and knowledge of the world through experience and reflection. It has had a profound impact on learner-centered teaching, a pedagogical approach that places the learner at the center of the educational process. In contrast to traditional teacher-centered methods, learner-centered teaching emphasizes students' agency, needs, and interests in the learning process.

#### 1. Theory of Constructivism

Constructivism argues that learners actively construct their own understanding and knowledge through their experiences, rather than passively receiving information from teachers. This theory, primarily associated with thinkers like Jean Piaget, Lev Vygotsky, and Jerome Bruner, posits that learning is an active, contextualized process in which learners build on prior knowledge to develop new insights.

#### A. Key Principles of Constructivism

##### 1. Active Learning:

- **Learner as an Active Participant:** Constructivism asserts that learners are not passive recipients of information. Instead, they actively engage with new material, exploring, questioning, and making sense of it by integrating it with their existing knowledge.
- **Learning by Doing:** Constructivists argue that students learn best when they are involved in hands-on, experiential activities that allow them to test their ideas and apply what they learn to real-world problems.

##### 2. Prior Knowledge:

- **Building on Existing Understanding:** According to constructivist theory, new learning is constructed on the foundation of what learners already know. Teachers need to activate students' prior knowledge to connect new concepts to familiar ideas, making learning more meaningful.
- **Knowledge as a Personal Construction:** Every learner constructs knowledge based on their unique experiences, so each learner may interpret the same information differently. This makes learning highly individualized.

## CHAPTER 4 Models of teaching

**DR. R. GUNASEKARAN**  
Assistant professor, School of Education,  
PRIST Deemed to Be University, Thanjavur.

**Models of Teaching** are instructional frameworks that provide specific strategies and methods to help teachers organize and deliver lessons effectively. These models are grounded in various educational theories and are designed to facilitate learning in different ways. Below are some well-known models of teaching, categorized based on their underlying educational philosophies and approaches.

### 1. The Information-Processing Models

Information-processing models focus on how learners receive, process, store, and retrieve information. These models emphasize the mental processes involved in learning and are often used to develop critical thinking, problem-solving, and knowledge acquisition skills.

#### A. Ausubel's Advance Organizer Model

- **Theory:** Based on David Ausubel's cognitive learning theory, this model helps learners integrate new information with existing cognitive structures.
- **Strategy:** Teachers provide "advance organizers" (such as outlines, concepts, or visual diagrams) before introducing new material to help students link new information to prior knowledge.
- **Use:** Effective in teaching complex subjects that require students to organize and understand large amounts of information (e.g., history, science).

#### B. Bruner's Concept Attainment Model

- **Theory:** Jerome Bruner's constructivist approach focuses on concept learning and inductive reasoning.
- **Strategy:** Teachers present examples and non-examples of a concept, prompting students to analyze and discover the defining characteristics of the concept through comparison and classification.
- **Use:** Useful for developing critical thinking and categorization skills (e.g., teaching scientific classification or historical concepts).

#### C. Inquiry-Based Learning Model

- **Theory:** Grounded in constructivism, this model emphasizes learning through exploration and investigation.
- **Strategy:** Teachers pose open-ended questions, and students investigate to discover answers through research, experimentation, and analysis.
- **Use:** Common in science education, inquiry-based learning encourages students to develop problem-solving and inquiry skills.

**CHAPTER 5**  
**Teaching as a Profession**  
**Prof. R. VAISHNAVI**  
**Assistant professor, School of Education,**  
**PRIST Deemed to Be University, Thanjavur.**

Teaching is a rewarding profession that involves educating and inspiring students. It requires a mix of knowledge, patience, creativity, and effective communication skills. Here are some key aspects:

1. **Role of a Teacher:** Teachers not only impart knowledge but also shape students' social and emotional development. They create a supportive learning environment and encourage critical thinking.
2. **Professional Development:** Continuous learning is crucial in teaching. Many educators pursue workshops, certifications, and advanced degrees to enhance their skills and stay updated on educational trends.
3. **Challenges:** Teachers face various challenges, including classroom management, diverse student needs, and administrative responsibilities. Finding effective strategies to address these challenges is essential.
4. **Impact on Society:** Teachers play a vital role in shaping future generations, promoting social values, and contributing to community development. Their influence extends beyond the classroom.
5. **Collaboration:** Working with colleagues, parents, and the community enhances the teaching experience and supports student success. Collaboration can lead to sharing resources and strategies.
6. **Job Satisfaction:** While teaching can be demanding, many educators find fulfillment in making a difference in students' lives and witnessing their growth.



## CHAPTER 6

**Techniques of active learning**  
**Prof. T. SUBHASHINI**  
**Assistant professor, School of Education,**  
**PRIST Deemed to Be University, Thanjavur.**

Active learning involves engaging students in the learning process, encouraging them to participate actively rather than passively receiving information. Here are some effective techniques:

1. **Think-Pair-Share:** Students think about a question individually, discuss their thoughts with a partner, and then share with the larger group. This promotes collaboration and critical thinking.
2. **Group Projects:** Assigning projects that require teamwork helps students learn from each other and develop problem-solving skills.
3. **Case Studies:** Presenting real-life scenarios for analysis encourages students to apply their knowledge and think critically about practical applications.
4. **Role Play and Simulations:** These activities immerse students in real-world situations, enhancing their understanding through experiential learning.
5. **Peer Teaching:** Students teach each other specific concepts or skills, reinforcing their understanding while building communication skills.
6. **Interactive Lectures:** Incorporate questions, polls, or discussions during lectures to keep students engaged and encourage participation.
7. **Journals and Reflections:** Encouraging students to maintain journals for reflection promotes self-assessment and deeper understanding of the material.
8. **Problem-Based Learning (PBL):** Presenting students with a problem to solve fosters critical thinking and encourages collaborative learning.
9. **Concept Mapping:** Students create visual representations of relationships among concepts, which helps clarify their understanding and organize information.
10. **Flipped Classroom:** Students review content at home (via videos or readings) and engage in hands-on activities and discussions in class, allowing for deeper exploration.

## CHAPTER 7

### Classroom – Diversity in the classroom

DR. R. GUNASEKARAN

Assistant professor, School of Education,  
PRIST Deemed to Be University, Thanjavur.

Diversity in the classroom refers to the variety of backgrounds, cultures, abilities, and perspectives that students bring to the learning environment. Embracing diversity can enrich the educational experience and foster an inclusive atmosphere. Here are some key points to consider:

1. **Cultural Diversity:** Students come from various cultural backgrounds, which can influence their learning styles, values, and perspectives. Incorporating diverse cultural materials and perspectives in the curriculum helps all students feel represented and respected.
2. **Learning Styles and Abilities:** Students have different learning preferences (visual, auditory, kinesthetic) and abilities (gifted, struggling, neurodiverse). Differentiated instruction and personalized learning strategies can address these differences effectively.
3. **Language Diversity:** In classrooms with English language learners (ELLs), it's important to use strategies that support language acquisition while also valuing students' native languages. This can include using visuals, scaffolding instruction, and providing opportunities for language practice.
4. **Social and Economic Diversity:** Students come from various socioeconomic backgrounds, which can impact their access to resources and educational support. Creating an inclusive classroom involves being aware of these differences and providing equitable opportunities for all students.
5. **Inclusion and Support:** Implementing inclusive practices, such as cooperative learning and peer support, fosters a sense of belonging. Establishing a classroom environment where all students feel valued encourages participation and engagement.
6. **Culturally Responsive Teaching:** This approach involves recognizing and incorporating students' cultural backgrounds into lessons. It acknowledges the strengths students bring to the classroom and connects learning to their experiences.

## CHAPTER 8

### learning Process

Prof. T. SELVARAJ

Assistant professor, School of Education,  
PRIST Deemed to Be University, Thanjavur.

The learning process is a dynamic and complex journey through which individuals acquire knowledge, skills, attitudes, and values. Here are some key components and stages of the learning process:

1. **Motivation:** Effective learning often begins with motivation. Intrinsic motivation (internal drive) and extrinsic motivation (external rewards) both play a role in engaging learners.
2. **Experience:** Learning typically starts with an experience, whether it's a new concept introduced in class, a hands-on activity, or a real-world application. Experiences serve as the foundation for building knowledge.
3. **Reflection:** Reflecting on experiences helps learners make sense of what they've encountered. This could involve thinking critically about the material, discussing with peers, or journaling.
4. **Assimilation and Accommodation:** According to Piaget's theory, learners assimilate new information by fitting it into existing knowledge frameworks, while accommodation involves adjusting those frameworks to incorporate new information.
5. **Active Engagement:** Engaging actively with the material (through discussions, problem-solving, or collaborative projects) helps deepen understanding and retention. Active learning strategies promote involvement and critical thinking.
6. **Feedback:** Constructive feedback is essential for growth. It helps learners identify strengths and areas for improvement, guiding their learning journey.
7. **Practice and Application:** Repeated practice and applying skills in various contexts reinforce learning. This can include exercises, projects, or real-life applications that solidify understanding.
8. **Transfer of Learning:** The ultimate goal is for learners to transfer what they've learned to new situations. This involves recognizing connections between different concepts and applying knowledge in diverse contexts.
9. **Assessment:** Ongoing assessment (both formative and summative) helps gauge understanding and progress. It can inform instructional adjustments and support personalized learning.
10. **Lifelong Learning:** The learning process doesn't stop at school. Encouraging a mindset of lifelong learning helps individuals continue to grow and adapt throughout their lives.

**CHAPTER 9**  
**Psychology Models**  
**Prof. R. VAISHNAVI**  
**Assistant professor, School of Education,**  
**PRIST Deemed to Be University, Thanjavur.**

Psychology models provide frameworks for understanding human behavior, thought processes, and emotions. Here are some prominent models used in psychology:

1. **Behavioral Model:** This model focuses on observable behaviors rather than internal mental states. It emphasizes the role of reinforcement and punishment in shaping behavior. Key figures include B.F. Skinner and John Watson.
2. **Cognitive Model:** This model centers on the mental processes involved in perception, memory, and problem-solving. It explores how thoughts influence feelings and behaviors. Aaron Beck and Albert Ellis are notable contributors to cognitive theory.
3. **Humanistic Model:** Humanistic psychology emphasizes individual potential and personal growth. It focuses on self-actualization and the importance of empathy and unconditional positive regard. Carl Rogers and Abraham Maslow are key figures, with Maslow's hierarchy of needs being a central concept.
4. **Psychoanalytic Model:** Founded by Sigmund Freud, this model emphasizes the influence of the unconscious mind on behavior. It explores concepts like defense mechanisms, childhood experiences, and the role of unconscious desires.
5. **Biopsychosocial Model:** This model integrates biological, psychological, and social factors in understanding behavior and mental health. It recognizes that multiple influences interact to affect an individual's well-being.
6. **Social Learning Theory:** Developed by Albert Bandura, this theory emphasizes learning through observation and imitation. It highlights the role of social context and modeling in behavior.
7. **Developmental Models:** These models, including Erik Erikson's stages of psychosocial development and Jean Piaget's stages of cognitive development, explore how individuals grow and change throughout their lifespan.
8. **Constructivist Model:** This model suggests that learners actively construct their own understanding and knowledge of the world, based on experiences and interactions. It emphasizes the role of social context in learning.
9. **Systems Theory:** This approach views behavior as part of a larger system, taking into account the interactions between individuals and their environments, including family, community, and cultural influences.
10. **Ecological Systems Theory:** Proposed by Urie Bronfenbrenner, this theory emphasizes the various systems that influence human development, from immediate environments (like family and school) to broader societal contexts.

## CHAPTER 10

**Teacher Professional Ethics**  
**Prof. T. SUBHASHINI**  
**Assistant professor, School of Education,**  
**PRIST Deemed to Be University, Thanjavur.**

Teacher professional ethics encompass the principles and standards that guide educators in their conduct and decision-making. These ethics are crucial for fostering a positive learning environment and maintaining trust with students, families, and the community. Here are some key aspects:

1. **Commitment to Students:** Teachers should prioritize the well-being and educational success of their students. This includes recognizing individual needs, fostering a safe environment, and promoting equity.
2. **Integrity and Honesty:** Educators must demonstrate honesty in their assessments, reporting, and interactions. This includes being transparent about expectations and maintaining professionalism in all communications.
3. **Respect for Diversity:** Teachers should value and respect the diverse backgrounds, cultures, and perspectives of their students. This involves creating an inclusive classroom that celebrates diversity and addresses bias.
4. **Confidentiality:** Maintaining the confidentiality of student information is essential. Teachers should safeguard personal and academic records and only share information on a need-to-know basis.
5. **Professional Competence:** Teachers are expected to pursue ongoing professional development to enhance their knowledge and skills. Staying informed about best practices and educational research is vital for effective teaching.
6. **Responsibility to the Profession:** Educators should uphold the integrity of the teaching profession by promoting its values, collaborating with colleagues, and participating in professional organizations.
7. **Fairness and Equity:** Teachers must ensure fair treatment of all students, providing equal opportunities for learning and addressing any forms of discrimination or favoritism.
8. **Collaboration with Families and Communities:** Engaging with families and the broader community is important for supporting student success. Teachers should communicate openly and work collaboratively with parents and guardians.
9. **Professional Boundaries:** Maintaining appropriate boundaries in relationships with students is essential to uphold professionalism. This includes avoiding dual relationships that could compromise the educator-student dynamic.
10. **Advocacy for Students:** Teachers have a responsibility to advocate for the needs and rights of their students, ensuring they have access to the resources and support necessary for their success.



# CONTEMPORARY INDIA AND EDUCATION

EDITED BY

**T.SUBHASHINI**



978-93-6255-036-1

Contemporary India and Education  
Copyright ©2020-2021by Prof. T.Subhashini

All rights reserved. No part of this book may be reproduced or transmitted in any form or by any means without written permission from the author.

ISBN:978-93-6255-036-1

Publisher: Ponnaiyah Ramajayam Institute of Science and Technology (PRIST)

## TABLE OF CONTENTS

Introduction .....	5
CHAPTER 1 Education in Contemporary India, Constitutional Context .....	15
DR. R. GUNASEKARAN	
CHAPTER 2 Understanding the Social Diversity .....	25
Prof. T. SUBHASHINI	
CHAPTER 3 Educational Demands of Individuals and Diverse Communities .....	47
Prof. R. VAISHNAVI	
CHAPTER 4 Language Policy in Education .....	68
Prof. T. SELVARAJ	
CHAPTER 5 Implications of Equality of Educational Opportunities .....	85
Prof. R. VAISHNAVI	
CHAPTER 6 Aims and Purpose of Education.....	107
Prof. T. SUBHASHINI	
CHAPTER 7 Levels of Social diversity.....	123
DR. R. GUNASEKARAN	
CHAPTER 8 Universalization of Primary Education .....	137
Prof. T. SELVARAJ	
CHAPTER 9 Views of great thinkers.....	151
Prof. R. VAISHNAVI	
CHAPTER 10 Elimination of Social inequalities .....	163
Prof. T. SUBHASHINI	
REFERENCES.....	171



**CHAPTER 1**  
**Education in Contemporary India, Constitutional Context**  
**Dr. R. GUNASEKARAN**

Assistant Professor, School of Education, PRIST Deemed to be University, Thanjavur

.....

Education in contemporary India is shaped by a combination of constitutional mandates, government policies, and the challenges posed by the country's diverse socioeconomic landscape. The Indian Constitution enshrines education as a fundamental right, and several amendments and policies over the years have aimed at making education more accessible, equitable, and inclusive.

### **Constitutional Context**

**1. Fundamental Right to Education:**

- **Article 21A:** The 86th Constitutional Amendment Act, 2002, introduced Article 21A, which mandates free and compulsory education for all children between the ages of 6 and 14. This right ensures that every child has access to basic education without financial or societal barriers.

**2. Directive Principles of State Policy:**

- **Article 45:** The Constitution initially included the provision under Article 45, which aimed to provide free and compulsory education for all children up to the age of 14 within ten years of the Constitution's enactment. Though this remained a Directive Principle until Article 21A was introduced, it set the foundation for the state's responsibility in providing education.
- **Article 41 and Article 46:** These articles direct the state to secure the right to education and promote the educational interests of marginalized groups like Scheduled Castes (SCs), Scheduled Tribes (STs), and other socially and educationally backward classes.

**3. Cultural and Minority Rights:**

- **Article 29 and Article 30:** These articles protect the rights of minorities to conserve their culture and language and give them the right to establish and administer their own educational institutions. This allows minorities to have autonomy in education while being a part of the larger national framework.

**4. Reservations and Affirmative Action:**

- The Constitution also provides for **reservations in educational institutions** for SCs, STs, and Other Backward Classes (OBCs) under Articles 15(4) and 15(5), helping ensure that historically disadvantaged groups have access to higher education.

### **Major Educational Policies Influenced by the Constitution**

- 1. National Policy on Education (1986):** This policy aimed to overhaul the education system, promoting equality and addressing the needs of marginalized communities. It emphasized the need for universalizing elementary education and increasing investment in education.

**CHAPTER 2**  
**Understanding the Social Diversity**  
**Prof. T. SUBHASHINI**

Assistant Professor, School of Education, PRIST Deemed to be University, Thanjavur  
.....

**Social diversity** refers to the presence of a wide variety of social, cultural, and demographic differences within a society. In the context of India, this diversity is extensive due to the country's complex history, geography, and population composition. Understanding social diversity in India involves recognizing the variety of languages, religions, castes, ethnic groups, and socioeconomic statuses that coexist, as well as the unique challenges and opportunities this diversity creates.

**Key Aspects of Social Diversity in India**

**1. Caste System:**

- One of the most defining features of social stratification in India is the caste system, which has historically organized society into hierarchical groups. These groups, such as Brahmins, Kshatriyas, Vaishyas, and Shudras, along with Dalits (formerly referred to as "untouchables"), continue to influence social dynamics, though caste-based discrimination is now outlawed.
- The **Constitution of India** provides for the abolition of untouchability (Article 17) and affirmative action (reservations in education and jobs) for Scheduled Castes (SCs), Scheduled Tribes (STs), and Other Backward Classes (OBCs).

**2. Religious Diversity:**

- India is home to multiple religions, including Hinduism, Islam, Christianity, Sikhism, Buddhism, and Jainism. Hinduism is the largest religion, but India has one of the world's largest Muslim populations, as well as significant Christian, Sikh, and other religious communities.
- **Article 25-28** of the Indian Constitution guarantees religious freedom, allowing individuals to practice, propagate, and profess their faiths.

**3. Linguistic Diversity:**

- India recognizes 22 scheduled languages in its Constitution, but hundreds of languages and dialects are spoken across the country. Hindi and English are official languages, but states often conduct governance in their regional languages.
- Linguistic diversity plays a vital role in the identity of communities, with some states formed based on linguistic lines, such as Andhra Pradesh and Maharashtra.

**4. Tribal Diversity:**

- India has a substantial indigenous population, commonly referred to as Adivasis, who belong to various tribal groups. Each tribal group has its own language, culture, and social norms. Many of them live in remote areas, and they face challenges related to economic development, education, and displacement due to industrial projects.
- The Constitution provides special protections for these groups, including political representation and land rights under the Fifth and Sixth Schedules.

**CHAPTER 3**  
**Educational Demands of Individuals and Diverse Communities**  
**Prof. R. VAISHNAVI**

Assistant Professor, School of Education, PRIST Deemed to be University, Thanjavur  
.....

The **educational demands** of individuals and diverse communities in India reflect the country's social, cultural, linguistic, and economic diversity. Catering to these varied demands is crucial for creating an inclusive and equitable education system that promotes the development of individuals while addressing the unique needs of different communities.

### **Educational Demands of Individuals**

**1. Personalized Learning Needs:**

- **Learning Styles and Pace:** Different individuals have distinct learning styles (visual, auditory, kinesthetic, etc.) and paces. Educational institutions are increasingly recognizing the need for more flexible, student-centered approaches rather than a one-size-fits-all model.
- **Special Education Needs (SEN):** Children with disabilities, including physical, cognitive, or learning disabilities (e.g., dyslexia, autism), require individualized support and inclusive learning environments. The demand for special educators and adaptive technology is growing.

**2. Skill-Based Education:**

- With rapid technological changes and evolving job markets, there is an increasing demand for education that focuses on developing practical skills like digital literacy, critical thinking, problem-solving, and technical expertise. Vocational training and skill-development programs are essential for bridging the gap between education and employment.

**3. Higher Education and Career Preparation:**

- As the global economy becomes more competitive, individuals are seeking higher education not only for knowledge but also for career preparation. There is growing demand for courses that are aligned with emerging industries, such as artificial intelligence (AI), data science, and renewable energy, in addition to traditional academic pathways.

**4. Lifelong Learning:**

- With changing career landscapes, many individuals are seeking continuous learning opportunities throughout their lives. This has led to a demand for adult education, online learning platforms, and certification programs that allow professionals to upskill or reskill in various fields.

**5. Inclusive and Safe Learning Environment:**

- There is a rising demand for educational institutions to create inclusive and safe environments, free from discrimination based on gender, caste, religion, or socioeconomic status. Students are increasingly advocating for mental health support, gender-neutral policies, and the prevention of bullying or harassment in schools and colleges.

## CHAPTER 4 Language Policy in Education

**Prof. T. SELVARAJ**

Assistant Professor, School of Education, PRIST Deemed to be University, Thanjavur

.....

India's **language policy in education** is a reflection of its linguistic diversity and the need to balance national unity with regional linguistic identities. Language plays a critical role in education, both as a medium of instruction and as a subject of study. The language policy has evolved to accommodate multiple languages, promote inclusive education, and address regional and cultural sensitivities.

### Constitutional Provisions

The **Indian Constitution** acknowledges the importance of linguistic diversity and lays out several provisions for the use of languages in education:

1. **Article 343 and Article 351:** These articles deal with the official language of the Union (Hindi) and its promotion. However, English continues to be used as an associate official language.
2. **Article 29 and Article 30:** These articles protect the rights of linguistic minorities, allowing them to preserve their languages and establish educational institutions.
3. **Article 350A:** It directs the state to provide facilities for instruction in the mother tongue at the primary stage of education for children belonging to linguistic minority groups.
4. **Eighth Schedule:** The Constitution recognizes 22 languages under the Eighth Schedule, including major regional languages such as Bengali, Telugu, Tamil, Marathi, Urdu, and others.

### Key Language Policies in Education

#### 1. Three-Language Formula

The **Three-Language Formula**, introduced by the **National Policy on Education (NPE) 1968** and reiterated in subsequent education policies (NPE 1986, NEP 2020), aims to promote multilingualism and national unity. The formula advocates:

- **First Language:** The mother tongue or regional language.
- **Second Language:** In Hindi-speaking states, this is typically English or another modern Indian language. In non-Hindi-speaking states, Hindi is the second language.
- **Third Language:** In Hindi-speaking states, this is usually a modern Indian language, while in non-Hindi-speaking states, English is often chosen.

The goal of the three-language formula is to ensure that students are proficient in their mother tongue, one regional or national language, and one international language (typically English).

## CHAPTER 5 Implications of Equality of Educational Opportunities

Prof. R. VAISHNAVI

Assistant Professor, School of Education, PRIST Deemed to be University, Thanjavur

.....

The **equality of educational opportunities** refers to providing all individuals, regardless of their background, with equal access to quality education, free from discrimination based on factors such as caste, class, gender, religion, ethnicity, or geographic location. Ensuring this equality is essential for social justice, economic development, and the creation of an inclusive society. In India, equality of educational opportunities is not only a constitutional right but also a vital goal for national development.

### Implications of Equality of Educational Opportunities

#### 1. Social Justice and Inclusivity

- **Reduction of Social Inequalities:** Equal educational opportunities help reduce historical and social inequalities, particularly those based on caste, gender, religion, and economic status. In India, marginalized groups like Scheduled Castes (SCs), Scheduled Tribes (STs), Other Backward Classes (OBCs), and religious minorities have historically faced systemic discrimination. Equal access to education can empower these groups and promote social mobility.
- **Inclusivity in Society:** When people from diverse backgrounds receive equal educational opportunities, society becomes more inclusive. Marginalized groups can better participate in political, economic, and social systems, fostering a sense of belonging and reducing social tensions.

#### 2. Economic Growth and Development

- **Skilled Workforce:** Providing equal educational opportunities ensures that individuals from all sections of society contribute to the economy by gaining the skills and knowledge needed for employment. This leads to a more skilled workforce, higher productivity, and innovation.
- **Poverty Alleviation:** Education is one of the most powerful tools for breaking the cycle of poverty. Ensuring equal educational opportunities allows individuals from low-income families to improve their living standards, create wealth, and contribute to the nation's economic growth.

#### 3. Human Capital Development

- **Maximizing Human Potential:** Equality of educational opportunities helps in developing the full potential of individuals by providing them with the knowledge, skills, and values required to succeed. This not only benefits the individuals but also enhances the country's human capital, leading to long-term development and prosperity.
- **Educational Attainment:** When barriers to education are removed, individuals have higher educational attainment levels. This can lead to greater participation in higher education, which is essential for research, development, and creating a knowledge-based economy.

## CHAPTER 6

### Aims and Purpose of Education Prof. T. SUBHASHINI

Assistant Professor, School of Education, PRIST Deemed to be University, Thanjavur

.....

The **aims and purpose of education** have been debated across societies and cultures, but they universally center on empowering individuals, contributing to societal progress, and fostering personal growth. Education is a multifaceted process that seeks to develop intellectual, moral, and practical capacities, shaping individuals into productive and responsible citizens. In a rapidly evolving world, education must adapt to address both traditional and contemporary challenges while preparing individuals to thrive in diverse environments.

#### 1. Holistic Development of the Individual

- **Intellectual Development:** One of the primary aims of education is to cultivate intellectual abilities, critical thinking, and a broad understanding of various disciplines. Education fosters curiosity, problem-solving, and the ability to analyze and apply knowledge.
- **Emotional and Psychological Growth:** Education plays a crucial role in helping individuals understand and manage their emotions, building self-awareness, empathy, and emotional intelligence. It supports mental health and well-being by promoting a balanced, reflective life.
- **Moral and Ethical Values:** Education aims to instill moral and ethical values, teaching individuals the principles of justice, fairness, honesty, and integrity. It encourages ethical behavior in personal and professional contexts.
- **Physical Development:** Education supports physical well-being by encouraging healthy habits, physical education, and knowledge about nutrition and fitness. It aims to promote a healthy lifestyle that contributes to overall personal development.

#### 2. Preparation for Citizenship and Social Responsibility

- **Democratic Participation:** Education aims to prepare individuals for active participation in democracy, teaching them about their rights and responsibilities as citizens. It fosters a sense of civic duty, encouraging engagement with political and social issues.
- **Social Cohesion:** Through education, individuals learn to live in harmony with others, respecting diversity and contributing to social cohesion. Education plays a vital role in promoting tolerance, inclusion, and understanding across cultural, religious, and linguistic differences.

## CHAPTER 7

### Levels of Social diversity

DR. R. GUNASEKARAN

Assistant Professor, School of Education, PRIST Deemed to be University, Thanjavur

.....

**Social diversity** refers to the variety of social identities and differences within a society, including cultural, linguistic, religious, ethnic, and economic variations. It acknowledges that people belong to different social groups with distinct identities, experiences, and perspectives. Social diversity can be examined at multiple levels, and these levels often overlap, contributing to the complex fabric of society.

Here are the main **levels of social diversity**:

### 1. Cultural Diversity

- **Definition:** Cultural diversity refers to the differences in cultural practices, beliefs, values, and traditions among various groups within a society.
- **Examples:** In India, cultural diversity is evident in the wide range of festivals, cuisines, art forms, and traditions practiced across different regions and communities.
- **Impact:** Cultural diversity enriches societies by introducing a variety of perspectives and practices. It also fosters a deeper understanding and appreciation of different ways of life, encouraging mutual respect and tolerance.

### 2. Linguistic Diversity

- **Definition:** Linguistic diversity refers to the variety of languages spoken within a society. It also includes dialects, variations in speech, and multilingualism.
- **Examples:** India is home to over 1,600 languages and dialects, with 22 languages officially recognized under the Eighth Schedule of the Constitution. States and regions often have their own official languages, such as Hindi, Tamil, Telugu, and Bengali.
- **Impact:** Linguistic diversity can be both enriching and challenging. While it promotes cultural richness, it also requires policies to ensure that all linguistic groups have equal access to education, government services, and other opportunities.

### 3. Religious Diversity

- **Definition:** Religious diversity refers to the presence of multiple religious beliefs, practices, and identities within a society.

**Examples:** India is known for its religious diversity, with Hinduism, Islam, Christianity, Sikhism, Buddhism, and Jainism being the major religions practiced. Smaller communities also follow religions such as Zoroastrianism and Judaism

## CHAPTER 8

### Universalization of Primary Education

**Prof. T. SELVARAJ**

Assistant Professor, School of Education, PRIST Deemed to be University, Thanjavur

.....

The **universalization of primary education** refers to the global commitment to ensure that every child, regardless of their background or circumstances, has access to free, compulsory, and quality primary education. This goal is fundamental to human rights, social development, and economic progress. In India, as well as internationally, the universalization of primary education has been a key focus of educational policy reforms and development agendas.

#### Importance of Universalization of Primary Education

1. **Human Rights:** Access to education is recognized as a basic human right under international frameworks such as the Universal Declaration of Human Rights (Article 26) and the Convention on the Rights of the Child (Article 28). Education is essential for personal development, freedom, and empowerment.
2. **Economic Growth:** Education is a key driver of economic development. A well-educated population is more likely to participate productively in the economy, fostering innovation, entrepreneurship, and higher income levels. Universalizing primary education builds a foundation for higher education and skills development, which are essential for economic prosperity.
3. **Social Development:** Universal primary education promotes social inclusion and equality by ensuring that all children, regardless of their socioeconomic status, have the opportunity to learn and succeed. It also helps in reducing inequalities and breaking the cycle of poverty, as educated individuals are better positioned to access opportunities and improve their living standards.
4. **Gender Equality:** Primary education plays a crucial role in promoting gender equality. It ensures that girls, who may face barriers to education in some societies, have the same opportunities as boys to receive an education. This helps reduce gender disparities and empowers women, leading to broader social and economic benefits.
5. **National Integration and Citizenship:** Universal primary education fosters national unity by instilling shared values, civic responsibility, and social cohesion. It helps individuals understand their roles as citizens, promoting democracy and participation in public life.



## CHAPTER 9

### Views of great thinkers

Prof. R. VAISHNAVI

Assistant Professor, School of Education, PRIST Deemed to be University, Thanjavur

.....

The views of great thinkers on education provide profound insights into its purpose, methods, and societal role. Throughout history, philosophers, reformers, and educators have contributed to the evolution of educational thought, shaping how we understand teaching and learning. Here are the views of some of the most influential thinkers on education:

#### 1. Plato (427–347 BCE)

- **Philosophy of Education:** Plato, a Greek philosopher, believed that education is essential for creating a just society. In his work *The Republic*, he argued that education should be designed to cultivate rational thinking and moral values.
- **Aims of Education:** Plato emphasized the development of an individual's intellectual and moral capacities. He proposed a system of education that focuses on nurturing the virtues of wisdom, courage, and justice.
- **Methodology:** Plato supported a hierarchical system of education where students are trained according to their abilities. He believed in the "Theory of Forms," where education is about guiding individuals from ignorance (shadows of reality) toward true knowledge (the Forms).
- **Quote:** "The object of education is to teach us to love what is beautiful."

#### 2. Aristotle (384–322 BCE)

- **Philosophy of Education:** A student of Plato, Aristotle believed that education should foster both the intellectual and moral development of individuals. He focused on the idea of developing virtue and character.
- **Aims of Education:** Aristotle believed that education should aim to achieve the "Golden Mean"—a balance between reason and emotion. The purpose of education is to produce well-rounded individuals capable of rational thought and ethical action.
- **Methodology:** He stressed practical learning through observation and experience, advocating for a balanced education that includes physical, mental, and moral training.
- **Quote:** "Educating the mind without educating the heart is no education at all."

## CHAPTER 10

### Elimination of Social inequalities

Prof. T. SUBHASHINI

Assistant Professor, School of Education, PRIST Deemed to be University, Thanjavur

.....

The **elimination of social inequalities** through education is a critical goal in creating a just, equitable, and inclusive society. Social inequalities are disparities that exist based on factors such as socioeconomic status, caste, gender, religion, ethnicity, or disability. These inequalities can limit access to resources, opportunities, and rights, including education. Education has a transformative potential to break these cycles of inequality by providing equal opportunities for all individuals, but to achieve this, specific challenges must be addressed.

### Importance of Eliminating Social Inequalities Through Education

1. **Equal Opportunity:** Access to quality education provides individuals from all backgrounds with the same opportunities to develop skills, knowledge, and values. Education is a key tool in leveling the playing field for marginalized communities.
2. **Economic Mobility:** Education empowers individuals to improve their socioeconomic status by providing the skills needed for higher-paying jobs and better career opportunities. By reducing economic inequalities, education promotes upward mobility.
3. **Social Justice:** Education fosters awareness and critical thinking, helping individuals recognize and challenge injustice. An educated population is more likely to participate in civic life, advocate for their rights, and demand social reforms that reduce inequality.
4. **Empowerment of Marginalized Groups:** For historically marginalized groups—such as women, lower castes, ethnic minorities, and people with disabilities—education offers a pathway to empowerment, allowing them to overcome barriers to participation in society.

### Forms of Social Inequality in Education

1. **Caste-Based Inequality (India-Specific):**
  - **Discrimination:** In India, caste-based discrimination is a major source of social inequality in education. Children from marginalized castes, such as Scheduled Castes (SCs) and Scheduled Tribes (STs), often face prejudice and lower expectations from teachers and peers, which affects their educational performance and retention.
  - **Access:** Students from these communities are more likely to attend poorly resourced schools, lack access to private tutoring, and experience higher dropout rates.
2. **Gender Inequality:**

**Access to Education:** In many parts of the world, girls are less likely to attend school due to cultural norms, early marriage, or the need for them to contribute to



# MATHEMATICAL PHYSICS

*Edited by*

**DR. M. SIVANANTHAM**



978-93-6255-634-9

Mathematical Physics

Copyright © 2018 by Dr. M. Sivanantham

All rights reserved. No part of this book may be reproduced or transmitted in any form or by any means without written permission from the author.

ISBN: 978-93-6255-634-9

Publisher: Ponnaiyah Ramajayam Institute of Science and Technology (PRIST)

## TABLE OF CONTENTS

Introduction.....	21
CHAPTER 1 Introduction to Vectors .....	23
<i>Dr. M. Sivanantham</i>	
CHAPTER 2 Linear Vector Space .....	37
<i>Dr. L. Chinnappa</i>	
CHAPTER 3 Complex Numbers .....	59
<i>Dr.S.Subashchandrabose</i>	
CHAPTER 4 Complex Analysis .....	79
<i>Dr.S.Subashchandrabose</i>	
CHAPTER 5 Matrices .....	98
<i>Dr. M. Sivanantham</i>	
CHAPTER 6 Fourier Series .....	120
<i>Dr. V. Vidhya</i>	
CHAPTER 7 Fourier Transforms.....	141
<i>Dr. V. Vidhya</i>	
CHAPTER 8 Laplace Transforms.....	162
<i>Dr. M. Silambarasan</i>	
CHAPTER 9 Inverse Laplace Transforms.....	183
<i>Dr. M. Silambarasan</i>	
CHAPTER 10 Special Functions .....	204
<i>Dr. Sutapa Ghosh</i>	
REFERENCES.....	228

# CHAPTER 1

## Introduction to Vectors

*Dr. M. Sivanantham*

*Department of Physics, PRIST Deemed to be University,  
Thanjavur-613403, Tamilnadu, India*

### Introduction

Vectors are fundamental mathematical and physical entities used to represent quantities that have both magnitude and direction. Unlike scalars, which only have magnitude (such as temperature or mass), vectors convey more information, making them essential in various fields like physics, engineering, computer science, and mathematics.

Vectors are versatile tools that provide a structured way to represent and manipulate directional quantities. Their wide range of applications across different fields highlights their importance in both theoretical and practical aspects of science and engineering. Understanding vector operations and properties is crucial for anyone engaging in quantitative analysis or physical modeling.

### Definition and Representation

A vector is typically represented as an arrow, where the length of the arrow indicates the magnitude and the arrowhead points in the direction. In mathematical notation, vectors are often written in bold, like  $\mathbf{v}$ , or with an arrow above them, like  $\vec{v}$ . A vector in two dimensions (2D) can be written as  $\vec{v} = (x, y)$ , where  $x$  and  $y$  are the vector's components along the  $x$ -axis and  $y$ -axis, respectively. In three dimensions (3D), it is represented as  $\vec{v} = (x, y, z)$ .

### Types of Vectors

There are different types of vectors based on their properties:

**Zero Vector:** A vector with zero magnitude and no specific direction, represented as  $\vec{0} = (0, 0, 0)$ .

**Unit Vector:** A vector with a magnitude of 1, used to indicate direction.

**Position Vector:** Represents the position of a point relative to an origin.

**Equal Vectors:** Vectors that have the same magnitude and direction.

## CHAPTER 2

### Linear Vector Space

*Dr. L. Chinnappa*

*Department of Physics, PRIST Deemed to be University,  
Thanjavur-613403, Tamilnadu, India*

### Introduction

A linear vector space, also known simply as a vector space, is a fundamental concept in mathematics, particularly in linear algebra. It provides a structured framework for understanding and manipulating collections of vectors. Vector spaces are used extensively in various fields such as physics, engineering, computer science, and economics to model and solve a wide range of problems.

### Definition and Properties

A linear vector space  $V$  over a field  $F$  (such as the real numbers  $\mathbb{R}$  or the complex numbers  $\mathbb{C}$ ) is a set of elements, called vectors.

### Linear vector space

A linear vector space  $V$  is a collection of elements,  $\{V_i\}$ , which may be added and multiplied by scalars  $\{\alpha_i\}$  in such a way that

- the operation produces only elements of  $V$  (closure);
- addition and scalar multiplication follow the commutative and associative laws:
  - i)  $V_i + V_j = V_j + V_i$  (commutativity);
  - ii)  $V_i + (V_j + V_k) = (V_i + V_j) + V_k$  (associativity);
  - iii) there exists a null vector,  $0$ , in  $V$  such that  $0 + V_i = V_i + 0 = V_i$ ;
  - iv) for each vector  $V_i$  there exists an inverse ( $-V_i$ ) in  $V$  such that  $V_i + (-V_i) = 0$ ;
  - v)  $\alpha(V_i + V_j) = \alpha V_i + \alpha V_j$  ;
  - vi)  $(\alpha + \beta)V_i = \alpha V_i + \beta V_i$ ;
  - vii)  $\alpha(\beta V_i) = (\alpha\beta)V_i$ .

The domain of allowed scalars is called the field  $F$  over which  $V$  is defined. (Examples:  $F$  consists of all real numbers, or  $F$  consists of all complex numbers.)

## CHAPTER 3

### Complex Numbers

*Dr.S.Subashchandrabose*

*Department of Physics, PRIST Deemed to be University,*

*Thanjavur-613403, Tamilnadu, India*

#### Introduction

The concept of complex numbers was first mentioned in the 1<sup>st</sup> century by a Greek mathematician, Hero of Alexandria when he planned to calculate the square root of a negative number. But he simply altered the negative into positive and just took the numeric root value. Moreover, the real individuality of a complex number was stated in the 16<sup>th</sup> century by Italian mathematician Gerolamo Cardano, in the development of finding the negative roots of cubic and quadratic polynomial expressions. Complex numbers are commonly used for finding the square root of negative numbers.

Complex numbers have applications in various scientific research, signal processing, electromagnetism, fluid dynamics, quantum mechanics, and vibration analysis. Here we can understand the definition, terminology, visualization of complex numbers, properties, and operations of complex numbers.

#### What are Complex Numbers?

A complex number is the sum of a real number and an imaginary number. A complex number is of the form  $a + ib$  and is usually represented by  $z$ . Here both  $a$  and  $b$  are real numbers. The value ' $a$ ' is called the real part which is denoted by  $\text{Re}(z)$ , and ' $b$ ' is called the imaginary part  $\text{Im}(z)$ . Also,  $ib$  is called an imaginary number.

Some of the examples of complex numbers are  $2+3i, -2-5i, 12+i, 22+3i, -2-5i, 12+i, 32$ , etc.

#### Power of $i$

The alphabet  $i$  is referred to as the iota and is helpful to represent the imaginary part of the complex number. Further the iota( $i$ ) is very helpful to find the [square root](#) of negative numbers. We have the value of  $i^2 = -1$ , and this is used to find the value of  $\sqrt{-4} = \sqrt{i^2 4} = \pm 2i$ . The value of  $i^2 = -1$  is the fundamental aspect of a complex number. Let us try and understand more about the increasing powers of  $i$ .

- $i = \sqrt{-1}$



## CHAPTER 4

### Complex Analysis

*Dr. S. Subashchandrabose*

*Department of Physics, PRIST Deemed to be University,  
Thanjavur-613403, Tamilnadu, India*

#### Introduction

Complex Analysis is a branch of mathematics that studies functions of complex numbers, blending geometric intuition with algebraic rigor. At its core, complex analysis extends the concepts of calculus to the complex plane, where every complex number can be represented as  $z = x + iy$ , with  $x$  and  $y$  being real numbers and  $i$  is the imaginary unit satisfying  $i^2 = -1$ . This rich mathematical landscape reveals profound insights not only within pure mathematics but also across various applied fields, including physics, engineering, and even number theory.

Complex Analysis stands as a cornerstone of modern mathematics, blending the abstract with the practical. Its elegant theories and tools not only enrich our understanding of mathematical concepts but also serve as essential instruments in tackling real-world problems across various scientific disciplines. Through the exploration of this fascinating field, one gains not just analytical techniques but also a profound appreciation for the interplay between mathematics and the complex structures that describe our universe.

One of the most striking features of complex analysis is the concept of holomorphic functions, which are functions that are complex differentiable in a neighborhood of every point in their domain. These functions possess remarkable properties, such as being infinitely differentiable and expressible as power series. A key result, known as Cauchy's Integral Theorem, illustrates the importance of contour integration, asserting that the integral of a holomorphic function over a closed contour is zero. This foundational theorem leads to powerful tools like Cauchy's Integral Formula, allowing for the computation of integrals and the evaluation of limits with remarkable ease.

Complex analysis also delves into the study of singularities, poles, and residues, facilitating the evaluation of integrals around these points through the Residue Theorem. This approach not only

## CHAPTER 5

### Matrices

*Dr. M. Sivanantham*

*Department of Physics, PRIST Deemed to be University,  
Thanjavur-613403, Tamilnadu, India*

#### **Introduction**

Matrices are vital mathematical concepts that show a critical role in numerous fields, including mathematics, physics, computer science, and engineering. A matrix is basically a square or rectangular array of numbers, or symbols, organized in rows and columns. Matrices can be used in complex data manipulation and problem-solving techniques, and hence they are essential in both fundamental hypothetical and applied circumstances.

Though idea of matrices has been known from ancient civilizations, it received interest in the 19<sup>th</sup> century based on the work of mathematicians like Arthur Cayley and James Sylvester. Currently, matrices are not only used in linear algebra but also assist as the pillar for algorithms in machine learning, graphics processing, and optimization problems.

Generally, matrices are represented by uppercase letters (e.g., A, B, C) and size of the matrices ranging from minor  $2 \times 2$  arrays to large multidimensional structures. The component present in a matrix is recognized by its location, stated by its row and column indices. Series of arithmetic processes namely, addition, subtraction, and multiplication can be executed on matrices based on quietly different instructions as compared to typical arithmetic.

Solving systems of linear equations is one of the most important applications of matrices. Solutions of matrices can be determined by Gaussian elimination or matrix inversion method. Matrices also offer an outline for data illustration in statistics and data science. For instance, data sets can be arranged into matrices where rows signify observations and columns denote variables, permitting for active analysis and conception. Moreover, matrices are integral to transformations in computer graphics, enabling the manipulation of shapes and images in a digital space.

Matrices are a versatile tool that bridges various disciplines, providing a systematic approach to dealing with linear relationships and complex data structures. Understanding matrices and their properties is essential for anyone engaging in quantitative fields,

## CHAPTER 6

### Fourier Series

*Dr. V. Vidhya*

*Department of Physics, PRIST Deemed to be University,  
Thanjavur-613403, Tamilnadu, India*

#### **Introduction**

Fourier series are a powerful mathematical tool used to analyze periodic functions by expressing them as the sum of sine and cosine functions. Named after the French mathematician Joseph Fourier, who introduced this concept in the early 19th century, Fourier series provide a framework for understanding how complex waveforms can be decomposed into simpler components.

The significance of Fourier series lies in their ability to approximate a wide variety of periodic functions, including square waves, sawtooth waves, and even more complex shapes. This decomposition allows for easier analysis and manipulation of functions, making Fourier series a staple in fields such as signal processing, electrical engineering, and acoustics.

One of the key applications of Fourier series is in the analysis of signals. In telecommunications, for example, Fourier series facilitate the representation of sound waves and other signals, allowing engineers to filter, compress, and synthesize audio and visual information efficiently. Additionally, Fourier series play a vital role in solving partial differential equations, particularly in physics and engineering, where they help describe phenomena such as heat conduction and wave propagation.

Fourier series also extend to the concept of Fourier transforms, which generalize the idea to non-periodic functions. This transformation is crucial in fields such as image processing and quantum mechanics, where understanding the frequency components of a signal or wave is essential.

Fourier series are a fundamental concept in mathematics and engineering, providing a robust method for analyzing and synthesizing periodic functions. Their ability to break down complex signals into simpler components underlies many technological advancements and theoretical developments, making them an essential tool in both academic research and practical applications. Understanding Fourier series opens the door to a

# CHAPTER 7

## Fourier Transforms

*Dr. V. Vidhya*

*Department of Physics, PRIST Deemed to be University,  
Thanjavur-613403, Tamilnadu, India*

### Introduction

Fourier transforms are a fundamental mathematical tool used to analyze and represent functions in terms of their frequency components. Extending the ideas introduced by Joseph Fourier through Fourier series, the Fourier transform provides a way to decompose complex signals into simpler sinusoidal components, allowing for a deeper understanding of their behavior in both time and frequency domains.

The power of Fourier transforms lies in their ability to analyze both periodic and non-periodic functions. Unlike Fourier series, which focus on periodic signals, the Fourier transform provides a comprehensive framework for dealing with a wide variety of functions, making it indispensable in many fields, including signal processing, communications, and physics.

One of the key applications of Fourier transforms is in signal processing, where they are used to filter, compress, and reconstruct signals. For instance, in audio processing, the Fourier transform helps separate different frequencies in a sound wave, allowing engineers to isolate specific sounds or remove noise. Similarly, in image processing, the Fourier transform enables operations such as image filtering and compression by analyzing the frequency components of pixel values.

In physics, Fourier transforms are crucial in the study of wave phenomena. They help in understanding how waves propagate and interact in various media, from sound waves in air to electromagnetic waves in space. The ability to switch between time and frequency domains provides insights into the behavior of physical systems and aids in solving differential equations that describe wave behavior.

Additionally, the Fast Fourier Transform (FFT) algorithm has revolutionized the field by allowing for efficient computation of Fourier transforms, making it possible to analyze large datasets and real-time signals rapidly. This efficiency is vital in modern

## CHAPTER 8

### Laplace Transforms

*Dr. M. Silambarasan*

*Department of Physics, PRIST Deemed to be University,*

*Thanjavur-613403, Tamilnadu, India*

#### Introduction

The Laplace transform is a powerful mathematical technique used to convert functions from the time domain into the complex frequency domain. Named after the French mathematician Pierre-Simon Laplace, this integral transform is particularly useful for analyzing linear time-invariant systems in engineering, physics, and applied mathematics.

One of the primary advantages of the Laplace transform is its ability to simplify the process of solving ordinary differential equations (ODEs). By transforming a differential equation into an algebraic equation, it becomes significantly easier to manipulate and solve. Once the algebraic solution is found, the inverse Laplace transform is used to convert the solution back into the time domain.

The Laplace transform is particularly effective for analyzing systems described by linear differential equations, making it invaluable in control theory and systems engineering. It allows engineers to study system behavior, stability, and response to inputs, such as step or impulse functions, through transfer functions. These transfer functions relate the input and output of a system in the frequency domain, facilitating design and analysis in various applications, including electrical circuits, mechanical systems, and signal processing.

Another important application of Laplace transforms is in the field of signal processing. They are used to analyze and design filters, control systems, and communication systems. The transform provides insights into the frequency response of systems, enabling the evaluation of system performance and stability.

Moreover, the Laplace transform has connections to other mathematical tools, such as Fourier transforms and Z-transforms. Each of these transforms serves different purposes, but they share the underlying principle of converting functions between domains, enriching the toolkit available for engineers and mathematicians.

## CHAPTER 9

### Inverse Laplace Transforms

*Dr. M. Silambarasan*

*Department of Physics, PRIST Deemed to be University,  
Thanjavur-613403, Tamilnadu, India*

#### **Introduction**

The inverse Laplace transform is a mathematical technique used to convert functions from the complex frequency domain back into the time domain. This process is essential in the fields of engineering, physics, and applied mathematics, where the Laplace transform is commonly employed to simplify the analysis of linear systems and solve ordinary differential equations (ODEs).

The primary purpose of the inverse Laplace transform is to revert the solutions of algebraic equations—obtained after applying the Laplace transform—back to the time domain, where they can be interpreted in the context of physical systems. This is particularly useful in control theory, signal processing, and circuit analysis, where engineers and scientists frequently work with systems modeled by differential equations.

One of the strengths of the inverse Laplace transform is its ability to handle a wide variety of functions, including those with discontinuities or impulsive behaviors. It allows for the analysis of system responses to different types of inputs, such as step, impulse, or sinusoidal functions. This capability is essential for designing stable and efficient systems in engineering applications.

Various methods exist for calculating inverse Laplace transforms, including partial fraction decomposition, the use of Laplace transform tables, and the residue theorem from complex analysis. These techniques provide straightforward approaches to find the inverse transform for many commonly encountered functions.

The inverse Laplace transform is a vital mathematical tool that enables the transition from the frequency domain back to the time domain. It plays a crucial role in the analysis and design of dynamic systems, allowing for a better understanding of how systems respond over time. Mastery of inverse Laplace transforms enhances problem-solving skills and is fundamental for anyone

**CHAPTER 10**  
**Special Functions**  
*Dr. Sutapa Ghosh*

*Department of Physics, PRIST Deemed to be University,  
Thanjavur-613403, Tamilnadu, India*

**Introduction**

Special functions are a class of mathematical functions that arise frequently in various fields of science and engineering. They often appear as solutions to differential equations, integrals, and series expansions that describe a wide range of physical phenomena. These functions have unique properties and behaviors that make them invaluable in theoretical and applied contexts, particularly in physics, engineering, and applied mathematics.

Among the most well-known special functions are the Bessel functions, Legendre polynomials, Hermite polynomials, and hypergeometric functions. Each of these functions is associated with specific types of problems. For instance, Bessel functions often emerge in problems involving cylindrical symmetry, such as heat conduction and wave propagation, while Legendre polynomials are pivotal in potential theory and electrostatics.

Special functions are characterized by their well-defined mathematical properties, including orthogonality, recurrence relations, and integral representations. These properties facilitate their application in various methods, such as Fourier series, Sturm-Liouville theory, and numerical analysis. Furthermore, many special functions can be expressed in terms of simpler functions, making them useful for approximations and computational techniques.

The study of special functions not only aids in solving complex equations but also enhances our understanding of the underlying mathematics. They serve as a bridge between pure mathematics and practical applications, allowing for elegant solutions to real-world problems. As computational tools and methods advance, the role of special functions continues to expand, providing deeper insights and solutions across disciplines.

Special functions are essential tools in mathematics and its applications, offering powerful solutions to a variety of problems while enriching the mathematical landscape. Understanding these