

Requires Authentication Published by De Gruyter 2024

13 Perspectives of microbial enzyme biocatalyst in food industries

From the book *Microbial Oxidative Enzymes*

Mariadhas Valan Arasu, Ki Choon Choi, Rengasamy Sathya, Soundharrajan Ilavenil, T. S. Rejiniemon, Ponnuswamy Vijayaraghavan, Balasubramanian Balamuralikrishnan and Prasant Arya
<https://doi.org/10.1515/9783111062235-013>

Cite this Share this

You are currently not able to access this content.

Not sure if you should have access? Please log in using an institutional account to see if you have access to view or download this content.
For more information see <https://www.degruyter.com/how-access-works>

Showing a limited preview of this publication:

Abstract

Microbial enzymes are useful for various industrial processes, including food preparation, and preparation of value added products. The state-of-art methods are used to produce various industrial enzymes with hyperactivity and enzymes with novel properties are continuously explored from various environmental conditions. Enzymes from animals and plants were used earlier. However, recent, microbial enzymes attracted much attention, because of increased production, simplicity, high substrate specificity and continuous supply to meet industrial demand. Microbial enzymes are affordable, simple to produce in large scale, and reliable to produce. The latest development in enzyme technology for the food sectors is discussed in the current chapter. The wide range of applications for these enzymes, as well as their microbial sources and extensive list of uses, are analyzed.

© 2023 Walter de Gruyter GmbH, Berlin/Boston



Access through your institution

— or —

Purchase
Chapter PDF

30,00 €

From the book



Microbial Oxidative Enzymes

Search book

Chapters in this book (28)

Frontmatter

Preface

Contents

 Requires Authentication · Published by De Gruyter 2024

14 Agro-food industrial residues into enzymes and other products using solid-state fermentation

From the book *Microbial Oxidative Enzymes*

Mariadhas Valan Arasu, Vágvölgyi Csaba, Rengasamy Sathya, Rakesh Varghese, Pankaj Kumar and R. C. Dubey

<https://doi.org/10.1515/978311062235-014>

[Cite this](#) [Share this](#)

You are currently not able to access this content.

Not sure if you should have access? Please log in using an institutional account to see if you have access to view or download this content. For more information see <https://www.degruyter.com/how-access-works>

Showing a limited preview of this publication:

Abstract

Agricultural wastes or agro-industrial residues are generated by the food processing industries throughout the world. These industries discharge solid waste (biomass) or liquid effluent into the environment. These solid wastes and effluents directly or indirectly affect the environment and human health negatively. Most of these wastes are lignocellulosic biomass that are a major source of several value-added bioproducts. Solid-state fermentation (SSF) is one of the fermentation methods used for the conversion of lignocellulosic biomass into various consumable products ranging from digestible sugar to bio-ethanol. Bacteria or fungi, or yeast utilizes this biomass and converts it into useful products. The application of fermentation technology improves the circular economy of industrialists. In SSF, the selection of substrate is very pivotal for product formation and the substrate specificity varies based on the type of organism involved. Bacteria, fungi, and yeast



Access through your institution

— or —

Purchase
Chapter PDF

30,00 €

From the book



Microbial Oxidative Enzymes

Search book



Chapters in this book (28)

Frontmatter

Preface

Contents

Volume 2901, Issue 1
15 December 2023

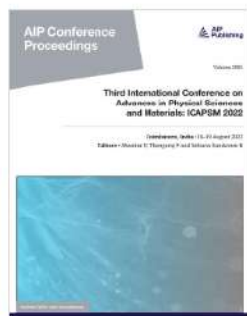

THIRD INTERNATIONAL CONFERENCE ON ADVANCES IN PHYSICAL SCIENCES AND MATERIALS: ICAPSM 2022
18–19 August 2022
Coimbatore, India

RESEARCH ARTICLE | DECEMBER 15 2023

Stereochemical analysis of an azabicyclo by single-crystal XRD

Paramasivam Parthiban , Palanlappen Ilayaraja

 Check for updates

+ Author & Article Information

AIP Conf. Proc. 2901, 020012 (2023)

<https://doi.org/10.1063/5.0179787>

 Share ▾

 Tools ▾

1-Methyl-2,4-bis(4-propoxyphenyl)-3-azabicyclo[3.3.1]nonan-9-one (1-Me-*p*-OPr ABN) was synthesized by tandem Mannich reaction in one-pot using 2-methylcyclohexan-1-one, 4-propoxybenzaldehyde, and NH_4OAc in an alcoholic medium. The XRD quality product was obtained through the gradual evaporation of ethyl alcohol after recrystallization. The observed formula of the compound is $\text{C}_{27}\text{H}_{34}\text{NO}_3$ with an orthorhombic crystal system ($\alpha=\beta=\gamma=90^\circ$) and *Pnma* space group. The observed molecular weight is 420.55, which differs from the actual (421.57) by a 50:50 ratio of the methyl at bridge-head carbons. A crystallographic mirror plane divides 1-Me-*p*-OPr ABN through O1, C3, N1 and C5. The synthesized compound is, in fact, a 1-methyl analogue of *p*-OPr ABN. However, the new molecule retains the twin-chair with equatorially oriented *p*-propoxyphenyl groups as the stereochemistry of *p*-OPr ABN. As indicated by the puckering parameters, the cyclohexane values ($Q_T=0.5314 \text{ \AA}$, $\theta=3.13^\circ$) are significantly away from the ideal whereas, the piperidine is not

 View Metrics

Citing Articles Via

Google Scholar

Publish with us -
Request a Quote!



APL Quantum

First Articles
Online

Read Now

 AIP

Books from IWA Publishing

[BROWSE](#) ▾ [EBOOKS](#) ▾ [LIBRARIANS](#) ▾ [OPEN ACCESS](#) [JOURNALS](#) [ABOUT](#) ▾

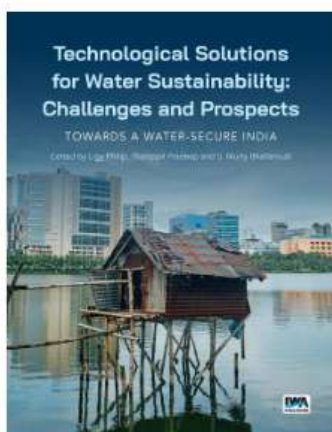

Technological Solutions for Water Sustainability: Challenges and Prospects: Towards a Water-secure India

Edited by [Ligy Philip](#);
[Thalappil Pradeep](#);
[S. Murty Bhallamudi](#)

IWA Publishing

DOI: <https://doi.org/10.2166/9781789063714>

BOOK CHAPTER

Chapter 4: Urban water infrastructure: current status and challenges in India

By [Sridhar Kumara Narasimhan](#);; [Shankar Narasimhan](#);; [S. Murty Bhallamudi](#);; [Ashutosh Das](#);; [M. S. Mohankumar](#)

DOI: https://doi.org/10.2166/9781789063714_0037

Published: November 2023

 [Chapter PDF](#)  [Share](#) ▾  [Tools](#) ▾

*Corresponding author: bsm@iitm.ac.in

© 2023 The Authors.

It is projected that by 2025, more than 50% of the population in the Global South will be living in urban areas accounting for a population of 3.75 billion. As the resources are limited, expanding cities in the Global South are facing severe crisis with regard to resource depletion, lack of space, equitable access to critical infrastructure, among other problems. Moreover, the existing infrastructure is aged and is in a dilapidated condition, requiring immediate attention. Adequate supply of water is not only important for living, but also from the perspective of hygiene, public health and control of diseases. However, despite the provision of adequate water, the incommensurate mismanagement of wastewater leads to non-hygienic conditions. Thus, provision of water supply infrastructure should necessarily go hand in hand with appropriate collection and management of wastewater. Further, management of rainwater and prevention of urban flooding through appropriate implementation of

Volume 2427, Issue 1
27 February 2023



3RD INTERNATIONAL CONFERENCE ON COMPUTATIONAL AND EXPERIMENTAL METHODS IN MECHANICAL ENGINEERING (11-13 FEBRUARY-2021):
Organized by the Department of Mechanical Engineering, G.L. Bajaj Institute of Technology and Management, Greater Noida, Uttar Pradesh, India

RESEARCH ARTICLE | FEBRUARY 27 2023

Multi objective energy management strategy for plug in hybrid electric vehicle

B. Vinoth Kumar ; P. Avirajamanjula



[+ Author & Article Information](#)

AIP Conf. Proc. 2427, 020065 (2023)

<https://doi.org/10.1063/5.0100867>



In a Plug-in hybrid vehicle, it is possible to get the required propulsion for the vehicle with more than one power source. This improves the performance of the vehicle and reduces energy loss. The Battery, Fuel cell, Ultracapacitor, Solar cell are the multiple energy source can be used in PHEV. This modern intelligent transport system is support to reduce the usage of fossil fuel and CO2 emission. The rule-based algorithm is used for optimizing the power flow between the traction motor and power source. The supervisory control strategy was verified through MATLAB simulation circuit. The technique has proved the improved performance of the vehicle and extended range of travel.

Topics

[Electric vehicles](#), [Fossil fuels](#), [Fuel cells](#), [Batteries](#), [MATLAB](#), [Supercapacitors](#)



[View Metrics](#)

Citing Articles Via

[Google Scholar](#)

Publish with us - Request a Quote!



APL Energy

Latest Articles Online!

Read Now

Volume 2427, Issue 1
27 February 2023

RESEARCH ARTICLE | FEBRUARY 27 2023

Extended driving range control strategy for hybrid electric vehicle

Vinoth Kumar Balan; P. Avirajamanjula

Check for updates

+ Author & Article Information

AIP Conf. Proc. 2427, 020046 (2023)

<https://doi.org/10.1063/5.0100860>

Share

Tools

View Metrics

Citing Articles Via

Google Scholar

Publish with us - Request a Quote!



APL Energy

Latest Articles Online!

Read Now



3RD INTERNATIONAL CONFERENCE ON COMPUTATIONAL AND EXPERIMENTAL METHODS IN MECHANICAL ENGINEERING (11-13 FEBRUARY-2021): Organized by the Department of Mechanical Engineering, G.L. Bajaj Institute of Technology and Management, Greater Noida, Uttar Pradesh, India
11-13 February 2021

The hybrid vehicle has reached a certain level in vehicle production, thus providing a solution for, carbon emission control, economic operation and vehicle maintenance. But Low energy storage in a hybrid vehicle is not conducive to long distance travel. For achieving the better performance of hybrid electric vehicle rule-based fuzzy logic controller and machine learning optimizing techniques are introduced. This system was simulated in MATLAB Simulink and results shows the performance of HEV is improved in significant level.

Topics

[Electric vehicles](#), [Energy storage](#), [MATLAB](#), [Machine learning](#), [Fuzzy logic](#)

Detecting Lung Nodules Based on Deep Learning with Automatic Segmentation

Publisher: IEEE

Cite This

PDF

Kishore Sebastian ; S. Devi All Authors

18 Full Text Views



Abstract

Abstract:

In this paper an efficient solution for detecting nodules in two-dimensional CT images is proposed. The method proposed here is based on the automatic segmentation of the lung parenchyma region, followed by the detection of possible nodules internal to this region. It is performed with the training of a neural network of the U-net type to perform the segmentation. The identification of the nodes is then performed using a convolutional neural network (CNN). The main contribution of this work resides in the node detection step, defined by the use of a CNN aggregated to the dimensionality reduction of data using the Principal Components Analysis method (PCA). Thus, with the objective of reducing the redundancy of the features extracted by CNN, the PCA was applied in the detection of possible nodes.

Published in: 2023 First International Conference on Advances in Electrical, Electronics and Computational Intelligence (ICAEECI)

Document Sections

- I. INTRODUCTION
- II. LITERATURE REVIEW
- III. MATERIALS AND METHODS
- IV. RESULTS AND DISCUSSION

Development of a Predictive Model of Burgling to Homes based on Machine Learning

Publisher: IEEE

Cite This

PDF

R. Ramji ; S. Devi All Authors

14 Full Text Views



Abstract

Document Sections

I. INTRODUCTION

LITERATURE REVIEW

Abstract:

The general objective of the paper is to determine the probability of burglary in the city of Chennai, and determine the factors that influence this type of crime, thus identifying the houses most prone to it. For this, the aforementioned public database of police cases is used to design and execute a python program based on neural networks that manages to obtain predictions of house robberies in different areas of the city. This paper investigates the relevant features in the obtained data sources to

All ▾



ADVANCED SEARCH

Conferences > 2023 7th International Confer...

Email Spam Behavioral Sieving Technique using Hybrid Algorithm

Publisher: IEEE

[Cite This](#)

[PDF](#)

S. Jancy Sickory Daisy ; A. Rijuvana Begum [All Authors](#)

1
Cites in
Paper

26
Full
Text Views



Abstract

Abstract:

Email spam filtering is a critical task in today's digital world due to the significant increase in the volume of spam emails. To address this issue, various machine learning (ML) and statistical techniques have been proposed to classify spam and ham emails accurately. This research study proposes a hybrid algorithm that combines two techniques: The Naive Bayes (NB) and the Support Vector Machine (SVM). The proposed algorithm first preprocesses the email data by removing stop words, stemming, and transforming the text data into a numerical format. Then, the NB algorithm is used to extract the relevant

Document Sections

I. INTRODUCTION

II. LITERATUR REVIEW



Machine Learning Approach for Anomaly-Based Intrusion Detection Systems Using Isolation Forest Model and Support Vector Machine

Publisher: IEEE

Cite This

PDF

K. Shanthi ; R. Maruthi [All Authors](#)

2
Cites in
Papers

374
Full
Text Views



Abstract

Document Sections

i. Introduction

ii. Related Works

Abstract:

Cyber Security plays a significant role in almost all the applications in the networks including host protection, network protection and cloud infrastructure protection. Designing an approach to intrusion detection Systems (IDS) in all levels is challenging and it requires more complex algorithms in today's world. Mainly it is very difficult to find abnormal behaviour in the cyber world because of the large amount of data. A precise and robust method for IDS has to be designed to overcome this issue to effectively secure the functioning of cloud Infrastructure. This study analyses the anomaly based intrusion detection Systems

A Comparative Study of Intrusion Detection and Prevention Systems for Cloud Environment

Publisher: IEEE

Cite This

PDF

K. Shanthi ; R. Maruthi **All Authors**

157

Full

Text Views



Abstract

Document Sections

I. Introduction

II. Related Works

Abstract:

Cloud Computing is an emerging technology for developing, deploying and accessing any applications and data. An Intrusion Detection System and Prevention Systems (IDPS) provide effective means to detect all types of malicious software and attacks in the networks. This kind of IDPS is very much essential in cloud environments for detection and prevention of attacks. This paper analyses the types of IDPS mechanisms for cloud environment to secure data and applications in the enterprise networks. The study discusses the strengths and weaknesses of the IDPS technologies used in the cloud infrastructure

All ▾



ADVANCED SEARCH

Conferences > 2023 Second International Con...

IoT based Illness Prediction System using Machine Learning

Publisher: IEEE

Cite This

PDF

B. Naga Lakshmi ; M. Robinson Joel **All Authors**

281

Full

Text Views



Abstract

Abstract:

The adoption of wearable technology will increase and its integration into daily life will improve, particularly in the healthcare sector. The emergence of mobile medicine, the development of new technologies like smart sensing, and the adoption of customised health ideas have all contributed to the rapid growth of smart wearable technology in recent years. The study was primarily focused on the use of wearable technology in office situations with the goal of daily health and safety monitoring of employees. In order to perform data classification and data labeling, a machine learning model is constructed. This research work has proposed a novel framework for processing data with text-related properties using machine learning techniques.

Document Sections

I. Introduction

II. Related Works

III. System Design and



All ▾



ADVANCED SEARCH

Conferences > 2023 Second International Con... ?

An Improved Soft Computing based Congestion Control in Routing the Data in Wireless Sensor Network

Publisher: IEEE

Cite This

PDF

K Manojkumar; S Devi **All Authors**

1

Cites in Paper

84

Full Text Views



Abstract

Abstract:

The congestion control is defined as a contrivance that is used to control and monitor the entry of data packets into the network. This helps to enhance and develop a better infrastructure in the communication network. The wireless sensor network is a communication network with infrastructure that are accompanied with less wireless network that is composed of innumerable nodes that are transportable through several instructions in the system. The nodes are interconnected in the communication system with each other in random fashion. The congestion is denoted as a decrease in the quality of service

Document Sections

I. Introduction

II. Proposed system





Scopus

Search

[Back to results](#) | [Previous](#) 15 of 25 [Next](#)

[Download](#) [Print](#) [Save to PDF](#) [Save to list](#) [Create bibliography](#)

A Closer Look at Silkworms - Pages vii - viii - 1 January 2023

Document type

Editorial

Source type

Book

ISBN

979-888697563-5, 979-888697563-5

[View more](#) ▾

Preface

Thangaraj, Pratheep

[Save all to author list](#)

^a Department of Biotechnology, PRIST Deemed to be University, Tamil Nadu, Tanjavur, India

[Full text options](#) ▾ [Export](#) ▾



A Closer Look at Silkworms

\$82.00 - \$135.00

Pratheep Thangaraj, PhD - Department of Biotechnology, PRIST Deemed to be University, Tanjavur, Tamil Nadu, India

Series: *Insects and Other Terrestrial Arthropods: Biology, Chemistry and Behavior*

BISAC: NAT005000; NAT017000; SCIO25000

DOI: 10.52305/WYEK3748

"Significant progress has been made in the past decade in sericulture research. Sericulture technique covering various aspects has also significantly advanced. Like agriculture, sericulture, as an industry, requires more incredible research and technology development to increase production. This book describes the complete range of subjects with current data relating to mulberry and silkworm. Overall this book emphasizes the fundamental aspects of the stable silkworm crop and various preventive measures against adverse factors. This book deserves **5 stars out of 5**. In fact, I would give this book one more star on the rating scale. Highly recommend." - **Dr. E. Gayathiri, Assistant Professor, Department of Plant Biology and Plant Biotechnology, Guru Nanak College (Autonomous), Chennai, India**

The first section of this book covers recent research developments on the silkworm, *B. mori*. Chapter One describes the recent advancements in utilization, product diversification and value addition of sericulture resources for the sustainability of farmers. Chapter Two compares the efficacy of silk production and how it is achieved through the growth and development of silkworms supplemented with antioxidants and exposed to low dose radiation from the gamma source. *B. mori* viral disease and lipid compositional changes during the spinning stage is the focus in the next two chapters. In Chapter Three, Tanmaya et al. review the characteristics of *B. mori* viruses, the classification of viral infections, mode of infectivity, transmission, symptomatology of viral diseases, detection of pathogenic viruses, the molecular mechanism of pathogenicity of viral diseases and insect antiviral defense mechanisms. Management practices can be carried out both at pre-rearing and rearing conditions for obtaining and improving qualitative and quantitative silk.

[Article preview](#)[Abstract](#)[Introduction](#)[Section snippets](#)[References \(21\)](#)

Stereochemical investigation of a diversely significant crystalline material

P. Parthiban^a , Y. Venkatarao^b[Show more](#) [+](#) [Add to Mendeley](#) [Share](#) [Cite](#)<https://doi.org/10.1016/j.matpr.2023.01.273>[Get rights and content](#)

Abstract

1-Methyl-2,4-bis(2-ethoxyphenyl)-3-azabicyclo[3.3.1]nonan-9-one (1-Me-*o*-OEt ABN) is a Mannich base, synthesized by an easiest and modified tandem condensations of 2-

[Article preview](#)[Abstract](#)[Introduction](#)[Section snippets](#)[References \(21\)](#)

Stereochemical investigation of a diversely significant crystalline material

P. Parthiban^a Y. Venkatarao^b[Show more](#) [+](#) [Add to Mendeley](#) [Share](#) [Cite](#)<https://doi.org/10.1016/j.matpr.2023.01.273>[Get rights and content](#)

Abstract

1-Methyl-2,4-bis(2-ethoxyphenyl)-3-azabicyclo[3.3.1]nonan-9-one (1-Me_o-OEt ABN) is a Mannich base, synthesized by an easiest and modified tandem condensations of 2-

TISSUE TALES UNRAVELING THE MYSTERIES OF CELLULAR ORGANIZATION

Edited by
GAYATHRI GANESAN



978-93-6255-515-1

Tissue tales - Unraveling the mysteries of Cellular Organization

Copyright©2023 by **Gayathri ganesan**

All rights reserved. No part of this book may be reproduced or transmitted in any form or by any means without written permission from the author.

ISBN: 978-93-6255-515-1

Publisher: Ponnaiyah Ramajayam Institute of Science and Technology (PRIST)

TABLE OF CONTENTS

| | |
|---|-----------|
| Introduction | 8 |
| Chapter I Inside the Cell: Journey into the World of Cell Organelles..... | 16 |
| Jasmine Manimaran | |
| Chapter II The Dance of Division: Understanding Mitotic Cell Division..... | 25 |
| Banumathi Ganesan | |
| Chapter III The Symphony of Diversity: Delving into Meiotic Cell Division..... | 33 |
| Sowbika Anand | |
| Chapter IV Botanical Anatomy – Exploring Tissue system in Plants..... | 42 |
| Akshaya Chelladurai | |
| Chapter V Chromosomes Unraveled: Structure, Types, and Functions | 50 |
| Gayathri Ganesan | |
| Chapter VI Genetic Complexity: Exploring the Realm of Multiple Alleles..... | 64 |
| Dr A Sathyavelu | |
| Chapter VII Mutation Marvels: Unveiling the Mysteries of Genetic Mutation..... | 72 |
| Dr B Chandrasekaran | |
| Chapter VIII Dominance Dynamics: Insights into Dominant Relationships in Genetics..... | 90 |

Dr D Jayakumar

**Chapter IX The Blueprint of Life: DNA and Cellular
Organization.....110**

Tamilcovane seshachalam

**Chapter X Future Frontiers: Innovations in Cellular and Tissue
Research.....130**

Udayakumar ayyavoo

REFERENCES..... 150

CHAPTER I

INSIDE THE CELL: JOURNEY INTO THE WORLD OF CELL ORGANELLES

JASMINE MANIMARAN

Assistant professor, School of Agriculture, Ponnaiyah Ramajeyam Institute of Science and technology, Tamilnadu, India

The aim of this chapter is to explore the fascinating realm of cell organelles, delving into their distinct structures, functions, and the crucial roles they play in cellular activities. By providing an in-depth examination of key organelles such as the nucleus, mitochondria, endoplasmic reticulum, Golgi apparatus, and others, this chapter seeks to illuminate how these specialized compartments contribute to the overall functionality and efficiency of the cell. Readers will gain a comprehensive understanding of how organelles work both independently and collaboratively to sustain life processes, and how their intricate interactions underpin the complexity of cellular organization.

Embarking on a journey into the world of cell organelles unveils the intricate and dynamic universe within each cell, revealing a complex network of specialized structures that drive the functions of life. At the heart of this microscopic world lies the nucleus, often considered the cell's command center. It houses the cell's genetic material, DNA, which contains the instructions for protein synthesis and other essential functions.

Mitochondria, frequently dubbed the "powerhouses" of the cell, are pivotal in energy production. These organelles convert nutrients into adenosine triphosphate (ATP), the cell's primary energy currency, through a process known as cellular respiration.

The endoplasmic reticulum (ER), a vast network of membranous tubules and sacs, plays a crucial role in protein and lipid synthesis.

CHAPTER II

THE DANCE OF DIVISION: UNDERSTANDING MITOTIC CELL DIVISION

BANUMATHI GANESAN

Assistant professor, School of Agriculture, Ponnaiyah Ramajeyam Institute of Science and technology , Tamilnadu, India

Mitotic cell division is the process by which a single eukaryotic cell divides to produce two genetically identical daughter cells. It involves a series of stages—prophase, metaphase, anaphase, and telophase—where chromosomes are replicated, aligned, and separated into two new nuclei. This ensures that each daughter cell receives an identical set of chromosomes. Mitotic division is essential for growth, repair, and asexual reproduction in organisms.

Prophase : Chromatin condenses into visible chromosomes, each consisting of two sister chromatids connected at the centromere. The nuclear envelope begins to break down, and the nucleolus disappears. The centrosomes move to opposite poles, forming the mitotic spindle, which will later facilitate chromosome movement.

Metaphase: Chromosomes align along the cell's equatorial plane, known as the metaphase plate. Spindle fibers attach to the centromeres of chromosomes via kinetochores, ensuring that each sister chromatid will be pulled to opposite poles.

Anaphase : The centromeres split, and spindle fibers shorten, pulling the sister chromatids apart towards opposite poles of the cell. This separation ensures that each daughter cell will receive an identical set of chromosomes.

Telophase : Chromosomes reach the poles and begin to decondense back into chromatin. The nuclear envelope reforms around each set of chromosomes, and the nucleolus reappears within each nucleus. This phase prepares the cell for cytokinesis, the final step where the cytoplasm divides to form two distinct daughter cells. Together, these phases of mitosis ensure the precise replication and distribution of genetic material, critical for cellular function and organismal growth.

CHAPTER III

THE SYMPHONY OF DIVERSITY: DELVING INTO MEIOTIC CELL DIVISION

SOWBIKA ANAND

Assistant professor, School of Agriculture, Ponnaiyah Ramajeyam Institute of Science and technology , Tamilnadu, India

Meiotic cell division is a specialized process that reduces the chromosome number by half, creating four genetically diverse haploid cells from one diploid parent cell. It is crucial for sexual reproduction and occurs in two successive stages: meiosis I and meiosis II.

In **Meiosis I** the reductional division where homologous chromosomes are separated. **Prophase I** : Chromosomes condense, and homologous chromosomes pair up and exchange genetic material through crossing-over. The nuclear envelope breaks down, and spindle fibers form. **Metaphase I** : Homologous chromosome pairs align along the metaphase plate. **Anaphase I** : Homologous chromosomes are pulled to opposite poles, but sister chromatids remain connected. **Telophase I** : Chromosomes reach the poles, and the cell divides into two haploid daughter cells, each with half the original chromosome number.

Meiosis II : This is the equational division, similar to mitosis, where sister chromatids are separated. **Prophase II** : Chromosomes condense again, and new spindle fibers form in each haploid cell. **Metaphase II** : Chromosomes align at the metaphase plate. **Anaphase II** : Sister chromatids are pulled apart to opposite poles. **Telophase II** : Chromatids reach the poles, and the cells divide, resulting in four genetically unique haploid cells.

CHAPTER IV

BOTANICAL ANATOMY – EXPLORING TISSUE SYSTEM IN PLANTS

AKSHAYA CHELLADURAI

Assistant professor, School of Agriculture, Ponnaiyah Ramajeyam Institute of Science and technology , Tamilnadu, India

The botanical tissue system is a fundamental organizational framework in plants, comprising three primary tissue types that each serve distinct yet interconnected functions essential for plant life. *The dermal tissue system* forms the outer protective layer, including the epidermis, which safeguards against environmental threats and water loss, and the periderm, which replaces the epidermis in woody plants. *The vascular tissue system* is crucial for the transport of water, nutrients, and organic compounds; it consists of xylem, responsible for moving water and minerals from roots to other parts, and phloem, which distributes the products of photosynthesis throughout the plant. *The ground tissue system* constitutes the bulk of the plant's internal structure, encompassing parenchyma for storage and photosynthesis, collenchyma for flexible support, and sclerenchyma for rigid structural reinforcement.

The ground tissue system is a major component of plant anatomy that provides support, storage, and various metabolic functions. It consists of three main types of tissues:

Parenchyma: These are the most versatile and common plant cells, characterized by their thin primary cell walls and large vacuoles. Parenchyma cells are involved in photosynthesis, especially in the leaves, and play a crucial role in storage of nutrients and water in other parts of the plant. They are also important for wound healing and regeneration. Followed by **Collenchyma**, these cells have thicker primary cell walls that provide flexible support to growing parts of the plant, such as stems and leaves. They help maintain structural integrity while allowing for growth and expansion, particularly in regions where elasticity is needed. **Sclerenchyma:** This tissue offers rigid support and strength due to its thick, lignified secondary cell walls. It includes fibers, which are long, slender cells providing tensile strength.

CHAPTER V

CHROMOSOMES UNRAVELED: STRUCTURE, TYPES, AND FUNCTIONS

GAYATHRI GANESAN

Assistant professor, School of Agriculture, Ponnaiyah Ramajeyam Institute of Science and technology , Tamilnadu, India

Chromosomes are fundamental structures within the nucleus of eukaryotic cells, responsible for carrying and organizing genetic information. Each chromosome is composed of a long DNA molecule wrapped around histone proteins, forming a complex called chromatin.

This chromatin condenses during cell division to become visible as distinct chromosomes. Each chromosome consists of two identical sister chromatids, joined together at a central region known as the centromere. The centromere is crucial for the proper segregation of chromosomes during cell division. At the ends of each chromosome are telomeres, protective caps that prevent the loss of genetic information and degradation. Additionally, the kinetochore, a protein structure located at the centromere, attaches the chromosome to spindle fibers, facilitating accurate chromosome movement. This intricate structure ensures the faithful transmission of genetic material from one generation to the next and is essential for proper cellular function and reproduction.

Chromosomes are vital for the proper functioning and continuity of life, serving as the primary vehicles for genetic information within cells. They organize and condense DNA into a manageable structure, allowing for efficient storage, protection, and transmission of genetic material.

During cell division, chromosomes ensure the precise distribution of genetic information to daughter cells, maintaining genetic continuity and stability. This process is crucial for growth, development, and tissue repair, as well as for the accurate inheritance of traits from one generation to the next

CHAPTER VI

GENETIC COMPLEXITY: EXPLORING THE REALM OF MULTIPLE ALLELES

DR A SATHYAVELU

*Professor, School of Agriculture, Ponnaiyah Ramajeyam Institute of Science and technology
, Tamilnadu, India*

Multiple alleles refer to the presence of more than two alternative forms of a gene that can occupy a single genetic locus. Unlike simple Mendelian traits, which are determined by only two alleles (one from each parent), traits governed by multiple alleles have more than two variations. A classic example of multiple alleles is the ABO blood group system in humans. In this system, the gene responsible for blood type has three common alleles: A, B, and O. The A and B alleles are codominant, meaning that both can be expressed simultaneously if present, while the O allele is recessive. This results in four possible blood types—A, B, AB, and O—depending on the combination of alleles inherited from each parent.

Genetic Diversity: Multiple alleles contribute to a greater range of genetic diversity within populations. This diversity enhances the adaptability and evolutionary potential of species by providing a broader array of phenotypic variations that can respond to environmental changes and selective pressures.

Complex Traits: They allow for the expression of more complex traits and phenotypes. In systems like the ABO blood group, multiple alleles result in a more nuanced classification of individuals, which is crucial for applications such as blood transfusions and organ transplants.

Inheritance Patterns: Understanding multiple alleles provides insights into more complex inheritance patterns beyond simple dominant-recessive relationships. This knowledge is essential for predicting genetic outcomes and understanding the inheritance of traits that do not follow Mendelian rules.

CHAPTER VII

MUTATION MARVELS: UNVEILING THE MYSTERIES OF GENETIC MUTATION

DR B CHANDRASEKARAN

*Professor, School of Agriculture, Ponnaiyah Ramajeyam Institute of Science and technology ,
Tamilnadu, India*

Genetic mutations are changes in the DNA sequence of an organism's genome that can occur spontaneously or be induced by external factors. These alterations can range from a single nucleotide change to large-scale chromosomal rearrangements. Mutations are categorized into several types:

Point Mutations : These involve a change in a single nucleotide base, which can be classified into silent mutations (no change in protein function), missense mutations (resulting in a different amino acid), and nonsense mutations (introducing a premature stop codon).

Insertions and Deletions: These mutations involve the addition or loss of nucleotides in the DNA sequence, potentially leading to frame shift mutations that alter the reading frame of the gene and can drastically affect protein function.

Duplication: This occurs when a segment of the DNA is copied more than once, potentially leading to an over expression of certain genes.

Inversions and Translocations: These involve rearrangements of chromosomal segments, which can disrupt gene function or lead to new gene combinations.

Mutations can have various effects on an organism, from beneficial adaptations that enhance survival and reproduction to deleterious changes that cause genetic disorders or increase susceptibility to diseases. While many mutations are neutral or harmful, some are crucial for genetic diversity and evolution, driving adaptation and speciation.

CHAPTER VIII

DOMINANCE DYNAMICS: INSIGHTS INTO DOMINANT RELATIONSHIPS IN GENETICS

DR D JAYAKUMAR

*Professor, School of Agriculture, Ponnaiyah Ramajeyam Institute of Science and technology
, Tamilnadu, India*

In genetics, a dominant relationship refers to the way certain alleles (versions of a gene) influence an organism's traits. Specifically, a dominant allele is one that masks the expression of a recessive allele when both are present in an organism.

Here's how it works: each individual has two alleles for a given gene—one inherited from each parent. If one allele is dominant and the other is recessive, the dominant allele will determine the organism's observable trait, or phenotype. For instance, if a gene for flower color has a dominant allele for red (R) and a recessive allele for white (r), a plant with at least one red allele (RR or Rr) will have red flowers, while only a plant with two recessive alleles (rr) will have white flowers.

Predicting Traits - It helps in predicting the inheritance patterns of traits. By understanding which alleles are dominant or recessive, geneticists can forecast the likelihood of certain traits appearing in offspring.

Genetic Disorders - Dominant relationships are important for understanding genetic disorders. For example, disorders like Huntington's disease are caused by dominant alleles. If a parent carries the dominant allele for a disorder, there is a 50% chance their child will inherit it, regardless of the other parent's genotype.

Selective Breeding- In agriculture and animal breeding, knowledge of dominant and recessive traits allows breeders to select for desirable characteristics. For instance, dominant traits such as disease resistance in crops can be propagated to improve yields and resilience.

CHAPTER IX

THE BLUEPRINT OF LIFE: DNA AND CELLULAR ORGANIZATION

TAMILCOVANE SESHACHALAM

Assistant professor, School of Agriculture, Ponnaiyah Ramajeyam Institute of Science and technology , Tamilnadu, India

DNA (deoxyribonucleic acid) is the fundamental molecule of genetic information in living organisms. It carries the instructions for the development, functioning, and reproduction of all known organisms and many viruses. DNA is structured as a double helix, with two intertwined strands forming a ladder-like structure, where the "steps" are pairs of nitrogenous bases: adenine (A) pairs with thymine (T), and guanine (G) pairs with cytosine (C). This sequence of base pairs encodes genetic instructions.

In terms of cellular organization, DNA is housed within the cell nucleus in eukaryotes, which include plants, animals, fungi, and protists. Within the nucleus, DNA is organized into structures called chromosomes. Each chromosome contains a single, long DNA molecule wrapped around proteins called histones, forming a complex known as chromatin. This organization allows DNA to be compacted and efficiently managed during cell division.

Prokaryotes, such as bacteria and archaea, do not have a membrane-bound nucleus. Instead, their DNA is located in a region called the nucleoid. The DNA in prokaryotes is typically circular and not associated with histones, though it is organized into supercoiled structures to fit within the cell.

In both eukaryotic and prokaryotic cells, the organization of DNA is crucial for regulating gene expression, ensuring accurate DNA replication, and facilitating repair processes.

CHAPTER X

FUTURE FRONTIERS: INNOVATIONS IN CELLULAR AND TISSUE RESEARCH

UDAYAKUMAR AYYAVOO

*Professor, School of Agriculture, Ponnaiyah Ramajeyam Institute of Science and technology
, Tamilnadu, India*

Innovations in cellular and tissue culture research have significantly advanced our understanding of biology and expanded the possibilities for medical and biotechnological applications. Here are some notable innovations in this field:

3D Cell Culture Systems Traditional 2D cell cultures often fail to accurately replicate the complex interactions of cells in vivo. 3D cell culture systems, such as organoids and spheroids, better mimic the three-dimensional structure and microenvironment of tissues, providing more realistic models for studying cell behavior, tissue development, and disease mechanisms.

Stem Cell Technologies : The development of stem cell culture techniques has revolutionized regenerative medicine and developmental biology. Embryonic stem cells and induced pluripotent stem cells (iPSCs) can differentiate into various cell types, offering potential for tissue repair, organ regeneration, and disease modeling.

CRISPR-Cas9 Gene Editing : The advent of CRISPR-Cas9 technology has transformed cellular research by enabling precise genetic modifications. This tool allows researchers to edit genes within cultured cells, facilitating the study of gene function, the creation of disease models, and the development of potential therapies.

Microfluidic Devices : Microfluidics involves the manipulation of fluids at a microscopic scale and has led to the creation of lab-on-a-chip devices.

Single-Cell Analysis : Advances in single-cell genomics and proteomics enable researchers to analyze the molecular profiles of individual cells.

Bioprinting : 3D bioprinting uses specialized printers to deposit layers of cells and biomaterials to create complex tissue structures.

FLO RICULTURE AND LANDSCAPE GARDENING

EDITED BY

DR. JAYAKUMAR DHAMODHARAN



978-93-6255-574-8

Microbial Mastery: FLORICULTURE AND LANDSCAPE AND GARDENING

Copyright © 2023 by Dr. Jayakumar Dhamodharan

All rights reserved. No part of this book may be reproduced or transmitted in any form or by any means without written permission from the author.

ISBN: 978-93-6255-574-8

Publisher: Ponnaiyah Ramajayam Institute of Science and Technology (PRIST)

TABLE OF CONTENT

| | |
|---|-----|
| Introduction..... | 6 |
| Chapter I: Floriculture | 15 |
| Ms. GOKILAPPRIYA DHANDAPANI | |
| Chapter II Horticulture crafts: A Profitable sector..... | 39 |
| DR. R.SENTHIL KUMAR | |
| Chapter III Softwares in landscape designing | 63 |
| MS. PRIYA DHARSHINI GOVINDARAJ | |
| Chapter IV: Value added products in Horticulture crops | 75 |
| DR. NIROJA DHARMALINGAM | |
| Chapter V : Post Harvest Technology in Horticulture crops | 103 |
| DR. PRIYANGA MURUGASEN, | |
| Chapter VI : Fundamentals in landscape designing | 121 |
| MS. GAYATHRI GANESAN | |
| Chapter VII: Lawn care | 135 |
| MS. SHARMITHA KRISHNA KUMAR | |
| Chapter VIII: Vertical Gardening Techniques | 152 |
| DR.B.GUNA | |
| Chapter IX : Designing for Seasonal Interest | 168 |
| DR.K.KUMARAKURU | |
| Chapter X: Water Features in Garden Design | 183 |
| MS.K.SHALINI | |

Chapter I

Floriculture

Ms. GOKILAPPRIYA DHANDAPANI

Assistant Professor, School of Agriculture,

Ponnaiyah Ramajayam Institute of Science and Technology, Tamil Nadu, India

Floriculture, a fascinating blend of art and science, represents a vibrant intersection where nature's beauty meets human ingenuity. At its core, floriculture is the cultivation and management of flowering plants for decorative purposes, and it has evolved into a dynamic field with profound impacts on our daily lives. This chapter introduces the multifaceted world of floriculture, exploring its historical roots, its current state, and its future potential. Historically, floriculture's origins can be traced back to ancient civilizations where flowers were not only appreciated for their beauty but were also imbued with symbolic meanings and used in religious rituals. The Egyptians, Greeks, and Romans, for example, cultivated gardens that showcased their understanding of plant aesthetics and their value in enhancing human environments. As time progressed, the Renaissance period marked a significant evolution, with floriculture gaining prominence as a refined art form among European aristocrats who celebrated the beauty of flowers in elaborate gardens and floral arrangements. In modern times, floriculture has blossomed into a sophisticated industry, characterized by both scientific advancement and artistic expression. Advances in horticultural technology, including soil science, pest management, and plant breeding, have revolutionized the way we grow and care for flowering plants. Simultaneously, the principles of design and aesthetics have refined the ways in which flowers are used to create compelling visual experiences, from grand floral displays to intimate home arrangements. Today, floriculture encompasses a wide range of activities—from large-scale commercial production to niche, artisanal practices. It is an industry driven by both economic and emotional factors, contributing significantly to economies through the production and sale of cut flowers, potted plants, and landscaping services. Beyond its economic impact, floriculture plays a crucial role in enhancing our quality of life. The simple act of arranging flowers can uplift moods, evoke emotions, and bring a touch of nature into our everyday spaces. As we delve into this chapter, we will explore the foundational aspects of floriculture, including the key practices involved in growing and caring for flowering plants.

Chapter II

Horticulture crafts: A Profitable sector

DR. R.SENTHIL KUMAR

Assistant Professor, School of Agriculture,

Ponnaiyah Ramajayam Institute of Science and Technology, Tamil Nadu, India

Horticulture crafts encompass a wide range of activities where the artistry of gardening intersects with practical and decorative purposes. From the intricate weaving of floral arrangements to the sculptural use of plants in living art installations, this sector offers a plethora of opportunities for those with a green thumb and a creative spirit. The growing consumer demand for unique, eco-friendly, and handcrafted products has fueled the rise of horticulture crafts, transforming what was once a hobby into a thriving industry. One of the key drivers of profitability in horticulture crafts is the increasing consumer inclination towards sustainable and personalized products. As environmental awareness escalates, more people are seeking out goods that are not only beautiful but also support ecological balance. Horticulture crafts, with their emphasis on natural materials and eco-friendly processes, align perfectly with these consumer values. This shift is reflected in the rising popularity of artisanal flower arrangements, bespoke terrariums, and innovative plant-based décor items. Moreover, the versatility of horticulture crafts allows for a diverse range of products and services, each catering to different market segments. From high-end luxury floral designs for weddings and corporate events to affordable, handcrafted planters and garden accessories for everyday consumers, the sector accommodates various price points and consumer preferences. This diversity not only broadens the market appeal but also provides multiple revenue streams for entrepreneurs and artisans. In addition to consumer trends, technological advancements have played a significant role in the growth of horticulture crafts. Modern tools and techniques enable artisans to experiment with new materials and methods, pushing the boundaries of traditional horticultural art. Online marketplaces and social media platforms further enhance visibility and reach, allowing crafters to showcase their creations to a global audience. In summary, the horticulture crafts sector represents a fusion of artistic innovation and environmental stewardship, offering both creative fulfillment and substantial economic opportunity. As this sector continues to evolve, it promises to expand its influence, driven by a growing demand for sustainable, handcrafted products and the ever-advancing capabilities of horticultural technology. This chapter will explore these dimensions in greater depth, uncovering the pathways to success in this vibrant and profitable field.

Chapter III

Softwares in landscape designing

MS. PRIYA DHARSHINI GOVINDARAJ

Assistant Professor, School of Agriculture,

Ponnaiyah Ramajayam Institute of Science and Technology, Tamil Nadu, India

In the evolving field of landscape design, software tools have revolutionized the way professionals conceptualize, plan, and execute their projects. Historically reliant on manual drawings and physical models, landscape designers now have access to a suite of advanced digital tools that streamline the design process, enhance creativity, and improve accuracy. This chapter introduces the pivotal role of software in landscape designing, exploring its impact on the industry, and providing an overview of the most prominent tools available today. Modern landscape design software offers a range of functionalities that cater to various stages of the design process. From initial concept sketches to detailed 3D renderings, these tools enable designers to visualize their ideas with unprecedented clarity and precision. Key software types include Computer-Aided Design (CAD) programs, Geographic Information Systems (GIS), and specialized landscape design platforms, each serving distinct purposes but often working in concert to achieve comprehensive project outcomes. CAD software, such as AutoCAD and Vectorworks, is integral to landscape design for its ability to produce detailed technical drawings and precise measurements. These tools allow designers to create accurate site plans, elevations, and sections, facilitating a more effective translation of concepts into buildable plans. GIS software, including ArcGIS and QGIS, complements CAD by providing spatial analysis and data management capabilities. GIS tools are invaluable for understanding environmental factors, analyzing site conditions, and integrating geographical data into the design process. Specialized landscape design software, such as SketchUp, Lumion, and Realtime Landscaping, offers unique features tailored to the needs of landscape architects. SketchUp is renowned for its intuitive 3D modeling capabilities, enabling designers to create detailed, interactive models of their projects. Lumion and other visualization tools help in producing realistic renderings and animations, providing clients with immersive visualizations that convey the final outcome more effectively than traditional methods. The integration of these tools has not only enhanced the technical precision of landscape designs but also expanded the creative possibilities available to designers. By leveraging advanced software, professionals can experiment with complex design elements, assess the impact of various design scenarios, and optimize their solutions for both aesthetic appeal and functional performance. As we delve into the specifics of these software tools and their applications in landscape design, it becomes clear that the marriage of technology and creativity has transformed the discipline. The ability to visualize, analyze, and present designs in dynamic and interactive ways has fundamentally altered how landscape architects approach their work, leading to more innovative and sustainable design solutions.

Chapter IV

Value added products in Horticulture crops

DR. NIROJA DHARMALINGAM

Assistant Professor, School of Agriculture,

Ponnaiyah Ramajayam Institute of Science and Technology, Tamil Nadu, India

In the dynamic world of horticulture, the pursuit of maximizing returns and enhancing product utility has led to a significant focus on value-added products. Horticultural crops, which encompass a diverse range of fruits, vegetables, nuts, and ornamental plants, offer immense opportunities for adding value through innovative processing and product development. Value-added products not only increase profitability for growers but also cater to evolving consumer preferences and contribute to sustainable agricultural practices. Value addition in horticulture refers to the transformation of raw horticultural products into more valuable forms through processing, packaging, branding, and marketing. This transformation can occur at various stages, from post-harvest handling to the creation of new products with unique attributes. For instance, fresh fruits and vegetables can be processed into juices, jams, and sauces, which not only extend their shelf life but also enhance their appeal and convenience for consumers. Similarly, niche markets for specialty products such as artisanal sauces, organic snacks, and functional foods have burgeoned, driven by a growing demand for healthier and more sustainable options. The concept of value addition extends beyond mere processing; it encompasses the entire supply chain, including enhanced packaging solutions that preserve product quality and extend market reach. Advances in technology and innovation have enabled horticulturalists to develop products with unique flavors, textures, and health benefits, thereby differentiating them in a competitive market. For example, the development of freeze-dried fruits preserves nutritional value while offering convenience and long shelf life, catering to busy consumers and those seeking portable, nutritious snacks. Incorporating value-added products into horticultural practices also supports sustainability. By maximizing the use of harvested crops and reducing waste, growers contribute to a more efficient and environmentally friendly agricultural system. This approach aligns with global trends towards sustainability, where reducing food waste and promoting circular economy principles are increasingly prioritized. Moreover, value-added products can create new revenue streams for farmers and small-scale producers, enabling them to diversify their income sources and reduce reliance on volatile markets. By developing and marketing unique products, growers can tap into niche markets and create brand loyalty, thus securing a more stable financial future.

Chapter V

Post Harvest Technology in Horticulture crops

DR. PRIYANGA MURUGASEN

Assistant Professor, School of Agriculture,

Ponnaiyah Ramajayam Institute of Science and Technology, Tamil Nadu, India

Post-harvest technology is a critical domain within horticulture, focusing on the handling, storage, and processing of crops after they have been harvested. This field is essential for extending the shelf life, maintaining quality, and maximizing the economic value of horticultural products such as fruits, vegetables, nuts, and ornamental plants. The significance of post-harvest technology in horticulture cannot be overstated; it directly impacts food security, consumer satisfaction, and the profitability of agricultural enterprises. Once harvested, horticultural crops are highly perishable and susceptible to a variety of quality-degrading factors. These include physiological changes, microbial infections, and mechanical damage, which can occur during the post-harvest period. Effective post-harvest management is therefore crucial to minimize losses and ensure that crops reach consumers in optimal condition. This involves a range of techniques and practices designed to preserve the freshness, nutritional value, and aesthetic appeal of the produce. One key aspect of post-harvest technology is the implementation of proper handling practices. Gentle handling techniques are essential to avoid physical damage, which can accelerate spoilage. This includes careful sorting, grading, and packaging, all of which play a role in maintaining the quality of the crops. Additionally, temperature management is vital; refrigeration and controlled atmospheres can significantly extend the shelf life of horticultural products by slowing down metabolic and microbial activities. Another important component of post-harvest technology is the use of preservation methods. Techniques such as drying, canning, freezing, and irradiation help to extend the usability of horticultural products while preserving their nutritional and sensory qualities. These methods also play a role in reducing food waste, which is a growing concern in global food systems. Post-harvest technology also intersects with innovations in agricultural practices. Advances in sensor technology, data analytics, and automation are increasingly being integrated into post-harvest systems. These innovations facilitate real-time monitoring of crop conditions and optimize storage environments, contributing to more efficient and effective post-harvest management. In conclusion, post-harvest technology in horticulture is a dynamic and multifaceted field that plays a pivotal role in the agricultural sector.

Chapter VI

Fundamentals in landscape designing

MS. GAYATHRI GANESAN

Assistant Professor, School of Agriculture,

Ponnaiyah Ramajayam Institute of Science and Technology, Tamil Nadu, India

Landscape design is both an art and a science, weaving together the natural environment with human needs to create harmonious, functional, and aesthetically pleasing outdoor spaces. At its core, landscape design involves the thoughtful arrangement of elements such as plants, structures, and surfaces to enhance the utility and beauty of an environment. This practice is grounded in principles that bridge creativity and practicality, reflecting an understanding of both environmental systems and human behavior. The essence of landscape design lies in its ability to transform spaces. Whether it's a sprawling park, a quaint garden, or an urban plaza, the design process begins with a comprehensive analysis of the site. This includes assessing the topography, soil quality, climate, and existing vegetation. Understanding these elements helps designers make informed decisions that respect the natural environment while meeting the functional and aesthetic needs of the users. Another fundamental aspect of landscape design is the concept of scale and proportion. Effective design carefully balances the size and placement of elements to create visually pleasing compositions and functional spaces. This involves considering how different areas of the landscape will be used and ensuring that elements such as pathways, seating areas, and plantings are appropriately scaled for their intended purposes. Color, texture, and form are also critical in landscape design. The interplay of these elements can influence mood and perception, creating spaces that are not only beautiful but also engaging and inviting. Designers use plant materials, hardscapes, and decorative features to craft environments that resonate with their intended users and fit seamlessly into their surroundings. Furthermore, sustainable practices are increasingly central to modern landscape design. Designers must navigate the challenges of climate change and environmental degradation by incorporating sustainable practices such as water-efficient landscaping, native plant selections, and the use of renewable materials. These practices ensure that landscapes are not only aesthetically pleasing but also resilient and environmentally responsible. This chapter will explore these fundamental principles of landscape design, providing a foundation for understanding how to create spaces that are both functional and inspiring. From site analysis and design theory to practical application and sustainability.

Chapter VII

Lawn care

MS. SHARMITHA KRISHNA KUMAR

Assistant Professor, School of Agriculture,

Ponnaiyah Ramajayam Institute of Science and Technology, Tamil Nadu, India

Landscape design is both an art and a science, weaving together the natural environment with human needs to create harmonious, functional, and aesthetically pleasing outdoor spaces. At its core, landscape design involves the thoughtful arrangement of elements such as plants, structures, and surfaces to enhance the utility and beauty of an environment. This practice is grounded in principles that bridge creativity and practicality, reflecting an understanding of both environmental systems and human behavior. The essence of landscape design lies in its ability to transform spaces. Whether it's a sprawling park, a quaint garden, or an urban plaza, the design process begins with a comprehensive analysis of the site. This includes assessing the topography, soil quality, climate, and existing vegetation. Understanding these elements helps designers make informed decisions that respect the natural environment while meeting the functional and aesthetic needs of the users.

Another fundamental aspect of landscape design is the concept of scale and proportion. Effective design carefully balances the size and placement of elements to create visually pleasing compositions and functional spaces. This involves considering how different areas of the landscape will be used and ensuring that elements such as pathways, seating areas, and plantings are appropriately scaled for their intended purposes. Color, texture, and form are also critical in landscape design. The interplay of these elements can influence mood and perception, creating spaces that are not only beautiful but also engaging and inviting. Designers use plant materials, hardscapes, and decorative features to craft environments that resonate with their intended users and fit seamlessly into their surroundings. Furthermore, sustainable practices are increasingly central to modern landscape design. Designers must navigate the challenges of climate change and environmental degradation by incorporating sustainable practices such as water-efficient landscaping, native plant selections, and the use of renewable materials. These practices ensure that landscapes are not only aesthetically pleasing but also resilient and environmentally responsible. This chapter will explore these fundamental principles of landscape design, providing a foundation for understanding how to create spaces.

Chapter VIII

Vertical Gardening Techniques

DR.B.GUNA

Assistant Professor, School of Agriculture,

Ponnaiyah Ramajayam Institute of Science and Technology, Tamil Nadu, India

In a world where urbanization continually encroaches on green spaces, vertical gardening has emerged as a revolutionary practice, offering a breath of fresh air to cityscapes and suburban settings alike. This innovative approach to gardening not only maximizes space but also enhances the aesthetic and environmental value of otherwise underutilized areas. Whether you're an apartment dweller with limited outdoor space or a homeowner looking to revitalize a dull wall, vertical gardening techniques provide a versatile solution to cultivate a lush, thriving garden. Vertical gardening involves growing plants in a manner that utilizes vertical space rather than the traditional horizontal expanse. By transforming walls, fences, and trellises into vibrant green canvases, vertical gardens enable gardeners to overcome spatial constraints and create dynamic, living displays. This method is not merely about planting upwards; it's about integrating nature into the architectural fabric of our lives, making gardens accessible to those who might otherwise be restricted by space or soil limitations. The origins of vertical gardening trace back to ancient civilizations, where plants were grown in hanging baskets or wall-mounted planters. However, modern techniques have evolved significantly, incorporating advanced materials and designs that allow for more sustainable and aesthetically pleasing outcomes. From modular systems and living walls to hydroponic setups and green facades, the variety of vertical gardening techniques reflects both the creativity and practicality of this gardening approach. Key benefits of vertical gardening include its ability to improve air quality, reduce urban heat islands, and provide insulation for buildings. By incorporating plants into urban environments, vertical gardens help mitigate the adverse effects of dense development and contribute to overall ecological balance. Additionally, they offer a means of growing fresh produce in limited spaces, fostering self-sufficiency and promoting healthier lifestyles. In this chapter, we will delve into various vertical gardening techniques, exploring their practical applications, design considerations, and the benefits they bring to both gardeners and the environment. We will cover everything from choosing the right plants and materials to installation methods and maintenance tips. Whether you're a seasoned gardener or a curious beginner, this introduction aims to equip you with the knowledge and inspiration to create your own vertical garden and experience the transformative power of growing upwards.

Chapter IX

Designing for Seasonal Interest

DR.K.KUMARAKURU

Assistant Professor, School of Agriculture,

Ponnaiyah Ramajayam Institute of Science and Technology, Tamil Nadu, India

Understand Your Climate and Zones Climate: Know the weather patterns, such as temperature ranges, precipitation, and sunlight hours. Hardiness Zone: Check your USDA hardiness zone to choose plants that will thrive in your area. Plan for Each Season Spring: Focus on early bloomers like crocuses, daffodils, and tulips. Consider shrubs like forsythia or magnolia that provide early color. Summer: Include a mix of perennials, annuals, and shrubs with long blooming periods. Plants like lavender, daylilies, and coneflowers are great choices. Fall: Opt for plants with vibrant fall foliage, such as maples and sumac. Ornamental grasses and asters can also add interest. Winter: Incorporate evergreens like pines or hollies and consider plants with interesting bark or berries. Winter interest can also come from sculptural elements or garden ornaments. Layer Your Plantings: Trees and Shrubs: Use these for structure and year-round interest. Choose varieties with different bloom times, foliage colors, and forms. Perennials: These come back each year and can be selected to provide color and texture through various seasons. Annuals: These provide vibrant colors and can be changed out seasonally. Incorporate Hardscaping: Pathways and Patios: Use materials like stone or brick that look good year-round. Structures: Arbors, trellises, and pergolas add vertical interest and can be adorned with seasonal vines or lights. Add Seasonal Accents, Containers: Use pots and planters with seasonal plants or decorations that can be easily changed out. Decorative Elements: Sculptures, birdbaths, and water features can provide interest in all seasons. Consider Textures and Forms Foliage Texture: Mix plants with different leaf shapes and textures to keep the garden visually interesting. Forms: Include plants with varying growth habits—spreading groundcovers, tall grasses, and compact shrubs. Create a Focal Point. Design a focal point that remains attractive year-round, such as a beautiful statue, a large container, or a striking trees. Plan for Maintenance Select plants that are suited to your level of maintenance and are resilient to local pests and diseases. Use Seasonal Lighting Install landscape lighting to highlight features and create ambiance in the evening, particularly during the shorter days of fall and winter. Regular Updates Adjust and refresh plantings and decorations as seasons change to maintain visual interest and adapt to any changes in the garden's condition.

Chapter X

Water Features in Garden Design

MS.K.SHALINI

Assistant Professor, School of Agriculture,

Ponnaiyah Ramajayam Institute of Science and Technology, Tamil Nadu, India

Water features have been integral to garden design for centuries, captivating our senses with their tranquil sounds and serene visuals. In the landscape of modern gardening, they continue to play a pivotal role, transforming outdoor spaces into personal oases of peace and beauty. Whether it's the gentle ripple of a koi pond, the grandeur of a cascading waterfall, or the simplicity of a bubbling fountain, water features offer more than just aesthetic appeal—they create a multi-sensory experience that can rejuvenate and inspire. Historically, water features were often symbols of wealth and power, gracing the gardens of ancient civilizations such as those of the Romans, Greeks, and Persians. These early designs ranged from elaborate palace fountains to reflective ponds, each serving as a testament to the sophistication and artistry of their creators. Today, while the opulence may vary, the core principles of incorporating water into garden spaces remain remarkably consistent: to harness nature's most soothing element to enhance and complement the surrounding environment. In contemporary garden design, water features are celebrated not only for their beauty but also for their ecological benefits. They attract wildlife, support diverse plant life, and contribute to the overall health of the garden ecosystem. The rhythmic sound of flowing water can mask unwanted noises, creating a peaceful retreat from the hustle and bustle of daily life. Moreover, water features often serve as focal points around which other design elements—such as seating areas, pathways, and plantings—are arranged, adding structure and cohesion to the garden layout. The process of integrating a water feature into garden design involves thoughtful consideration of both functional and aesthetic aspects. Designers must take into account the scale and style of the water element to ensure it harmonizes with the garden's overall theme. Additionally, practical considerations such as maintenance, water conservation, and the choice of materials play crucial roles in the successful implementation of a water feature. This chapter delves into the various types of water features, exploring their historical significance, modern applications, and the techniques used to create and maintain them. From ponds and fountains to streams and waterfalls, each type of water feature offers unique possibilities and challenges. By understanding these elements, gardeners and designers can make informed decisions to craft captivating and enduring outdoor spaces that celebrate the timeless allure of water.



TECHNIQUES IN
PEST
MANAGEMENT

Edited by
DR.D.NIROJA



978-93-6255-898-5

Techniques in pest management
Copyright © 2023 by Dr.D.Niroja

All rights reserved. No part of this book may be reproduced or transmitted in any form or by any means without written permission from the author.

ISBN: 978-93-6255-898-5

Publisher: Ponnaiyah Ramajayam Institute of Science and Technology (PRIST)

TABLE OF CONTENT

| | |
|--|-----|
| Introduction..... | 6 |
| Chapter I: Principles of integrated pest management..... | 12 |
| Dr.D.NIROJA | |
| Chapter II: Cultural control methods in pest management..... | 33 |
| Dr.R.SENTHILKUMAR | |
| Chapter III: Mechanical and physical pest control..... | 55 |
| Ms.N.DHIVYAPRIYA | |
| Chapter IV: Biological methods of pest management..... | 74 |
| Ms.G.GAYATHRI | |
| Chapter V: Semiochemicals in pest management..... | 92 |
| Ms.G.PRIYADHARSHINI | |
| Chapter VI: Sterility methods in pest management..... | 115 |
| Ms.D.GOKILAPPRIYA | |
| Chapter VII: Botanical insect pest management..... | 134 |
| Ms.R.PONMATHI | |
| Chapter VIII: Host plant resistance in pest management..... | 158 |
| Dr.M.PRIYANGA | |
| Chapter IX: Microbial control agents in pest management..... | 180 |
| Dr.D.JAYAKUMAR | |
| Chapter X: Chemical pest control..... | 207 |
| Ms.K.SHARMITHA | |
| REFERENCE:..... | |

CHAPTER I
PRINCIPLES OF INTEGRATED PEST MANAGEMENT

Dr.D.Niroja

Assistant Professor, School of Agriculture,

Ponnaiyah Ramajayam Institute of Science and Technology, Tamil Nadu, India.

Integrated Pest Management (IPM) represents a strategic and multifaceted approach to pest control that seeks to balance effective pest management with environmental stewardship and economic considerations. The principles of IPM are designed to provide a comprehensive framework for managing pest populations through a combination of prevention, monitoring, and control strategies. This introduction explores the core principles of IPM, their applications, and the benefits they offer in creating sustainable pest management solutions.

Core Principles of IPM

1. Prevention and Prevention Strategies

Prevention is the first and most crucial step in IPM. It involves implementing practices that minimize the risk of pest infestations before they occur. This can include habitat modification, such as improving sanitation, sealing entry points, and using pest-resistant varieties of plants. In agricultural settings, prevention may involve crop rotation, the use of cover crops, and proper field management to reduce pest habitats. For homes and businesses, maintaining cleanliness and proper food storage can significantly reduce the likelihood of pest invasions.

2. Monitoring and Accurate Identification

Effective pest management relies on accurate monitoring and identification. Regular inspections and monitoring help detect pest problems early and assess their severity. This involves identifying the specific pests present, understanding their life cycles, and determining the extent of their impact. Monitoring tools may include traps, visual inspections, and pest counts. Accurate identification is essential for selecting the most appropriate and targeted control measures, ensuring that interventions are both effective and efficient.

CHAPTER II

CULTURAL CONTROL METHODS IN PEST MANAGEMENT

Mr.R.Senthilkumar

Assistant Professor, School of Agriculture,

Ponnaiyah Ramajayam Institute of Science and Technology, Tamil Nadu, India.

Cultural Control Methods in Pest Management

Cultural control methods are integral components of integrated pest management (IPM) strategies, focusing on modifying agricultural practices to reduce pest populations and minimize their impact on crops. These methods leverage knowledge of pest biology and ecology to create conditions that are less favorable for pest development and reproduction. By incorporating cultural practices into pest management plans, farmers can enhance crop health and productivity while reducing reliance on chemical control measures.

1. Crop Rotation

Crop rotation involves changing the type of crop grown in a particular field each season or year. This practice disrupts the life cycles of pests that are specific to certain crops. By alternating crops, farmers can:

- **Reduce Pest Populations:** Many pests are adapted to specific crops and cannot survive or reproduce effectively on non-host plants. Rotating crops helps reduce the buildup of pest populations.
- **Minimize Soil-Borne Diseases:** Some pests and diseases are soil-borne and persist in the soil. Rotating crops helps break the cycle of soil-borne pathogens, reducing their prevalence.

2. Intercropping

Intercropping involves growing two or more crops simultaneously in the same field. This practice can provide several benefits for pest management:

- **Diversification:** By planting different crops together, intercropping reduces the concentration of any one plant species, which can make it more difficult for pests to locate and exploit their preferred host plants.
- **Natural Predators:** Certain intercrop combinations can attract beneficial insects, such as predators and parasitoids, that help control pest populations.

3. Trap Crops

Trap crops are plants that attract pests away from the main crop, serving as a decoy to protect the primary crop. These crops are usually more attractive to pests than the main crop and are planted around or within the main crop area. Benefits include:

CHAPTER III

MECHANICAL AND PHYSICAL PEST CONTROL

Ms.N.Dhivyapriya

Assistant Professor, School of Agriculture,

Ponnaiyah Ramajayam Institute of Science and Technology, Tamil Nadu, India.

Mechanical and Physical Pest Control

Mechanical and physical pest control methods involve the use of physical barriers, traps, and manual techniques to manage pest populations and reduce their impact on crops, structures, and environments. These approaches are fundamental components of integrated pest management (IPM) and offer environmentally friendly alternatives to chemical pest control. By implementing mechanical and physical control strategies, pest problems can be addressed effectively while minimizing harm to beneficial organisms and reducing reliance on synthetic pesticides.

1. Physical Barriers

Physical barriers are structures or materials designed to prevent pests from accessing crops or areas of concern. These barriers can be highly effective in protecting plants and buildings from pest damage.

- **Row Covers:** Lightweight fabrics or nets placed over crops create a physical barrier that prevents insects, such as aphids, beetles, and moths, from reaching the plants. Row covers also help protect crops from environmental factors such as frost and excessive sun.
- **Fencing:** Physical fences, such as mesh or netting, can keep larger pests, like deer or rabbits, away from garden areas or crops. Fencing is especially useful for protecting sensitive plants and preventing damage from wildlife.
- **Traps:** Various traps can capture or kill pests, reducing their populations. Examples include:
 - **Sticky Traps:** These are coated with an adhesive that captures flying insects, such as whiteflies and thrips, helping monitor and manage pest populations.
 - **Pheromone Traps:** These traps use synthetic pheromones to attract specific insect pests, allowing for targeted control and monitoring.

2. Manual Removal

Manual removal involves physically removing pests from crops or structures. This

CHAPTER IV
BIOLOGICAL METHODS OF PEST MANAGEMENT

Ms.G.Gayathiri

Assistant Professor, School of Agriculture,

Ponnaiyah Ramajayam Institute of Science and Technology, Tamil Nadu, India.

Biological methods of pest management are an integral component of Integrated Pest Management (IPM) that utilize natural processes and organisms to control pest populations. These methods leverage the interactions between pests and their natural enemies, aiming to reduce pest numbers and mitigate damage through ecological balance rather than chemical interventions. This introduction explores the principles and applications of biological pest management, highlighting its benefits, strategies, and the challenges involved in implementing these techniques.

Principles of Biological Pest Management

1. Natural Enemies and Their Role

Biological pest management relies on harnessing natural enemies of pests to regulate their populations. Natural enemies include predators, parasitoids, and pathogens. **Predators** such as ladybugs, lacewings, and spiders actively hunt and consume pests, reducing their numbers. **Parasitoids** are insects that lay their eggs on or inside pests, with the developing larvae feeding on the host, ultimately killing it. Examples include parasitic wasps that target specific pest species. **Pathogens**, including bacteria, fungi, and viruses, infect and kill pests, contributing to population control. Utilizing these natural enemies can help maintain pest populations at levels that do not cause significant harm.

2. Conservation of Natural Enemies

Conservation is a key strategy in biological pest management, involving practices that support and protect existing natural enemies in the environment. This includes maintaining habitat diversity, providing food sources and shelter for beneficial organisms, and minimizing the use of broad-spectrum pesticides that can harm these beneficial species. By creating an environment conducive to the survival and proliferation of natural enemies, their effectiveness in controlling pest populations is enhanced.

CHAPTER V

SEMIOCHEMICALS IN PEST MANAGEMENT

Ms.G.Priyadharshini

*Assistant Professor, School of Agriculture,
Ponnaiyah Ramajayam Institute of Science and Technology, Tamil Nadu, India.*

Semiochemicals in Pest Management

Semiochemicals are chemical compounds used in pest management to influence the behavior of insects and other organisms. They play a pivotal role in integrated pest management (IPM) strategies by exploiting the natural chemical communication systems of pests. By manipulating these chemical signals, semiochemicals can disrupt pest behavior, attract natural enemies, and monitor pest populations. Their application represents a sophisticated approach to pest control that is both environmentally friendly and highly targeted.

1. Types of Semiochemicals

Semiochemicals are broadly categorized into several types based on their function and the nature of their interaction with target organisms:

- **Pheromones:** These are chemical signals emitted by insects that affect the behavior or physiology of other individuals of the same species. Pheromones are used in pest management to:
 - **Attract Mates:** Synthetic sex pheromones can be used in traps to lure male insects, disrupting mating and reducing pest populations. For instance, sex pheromone traps are commonly employed to control moth pests in agricultural crops.
 - **Mass Trapping:** In addition to mating disruption, pheromone traps can be used for mass trapping of pests, such as the Mediterranean fruit fly, to significantly reduce their populations.
- **Kairomones:** These are chemicals released by one species that benefit another species by influencing its behavior. Kairomones can:
 - **Attract Natural Enemies:** Kairomones emitted by pest insects can attract their natural predators or parasitoids. For example, kairomones released by aphids can attract lacewings, which are natural enemies of aphids.
- **Allomones:** These are chemicals released by one species that benefit the emitter and are generally neutral or harmful to the receiver. Allomones can be used to:

CHAPTER VI

STERILITY METHODS IN PEST MANAGEMENT

Ms.D.Gokilappriya

*Assistant Professor, School of Agriculture,
Ponnaiyah Ramajayam Institute of Science and Technology, Tamil Nadu, India.*

Sterility methods in pest management are advanced techniques that aim to control pest populations by disrupting their reproductive capabilities. These methods rely on inducing sterility in pests to reduce their numbers and prevent them from reproducing, ultimately leading to a decline in their population. This chapter provides an overview of sterility methods, their applications, and their benefits and challenges in integrated pest management (IPM).

Sterility methods primarily include the use of sterilization techniques, such as the Sterile Insect Technique (SIT) and the use of genetic approaches to induce sterility. The Sterile Insect Technique involves mass-rearing and releasing large numbers of sterilized insects into the wild. These sterilized insects mate with wild individuals, but the resulting eggs do not hatch or produce offspring. Over time, this process leads to a reduction in the pest population as the number of fertile individuals decreases. SIT has been successfully used for various pests, including fruit flies, moths, and mosquitoes, demonstrating its effectiveness in managing pest populations.

Genetic approaches to inducing sterility include the release of genetically modified organisms (GMOs) or the use of genetic engineering to create pest strains with built-in sterility mechanisms. One example is the use of genetically engineered mosquitoes that carry a gene that either induces sterility in offspring or leads to the death of offspring. This approach has shown promise in controlling mosquito populations and reducing the spread of diseases such as malaria and dengue fever.

The benefits of sterility methods in pest management are significant. They provide a targeted approach to controlling pest populations without relying on chemical pesticides, which can have adverse environmental and health impacts. Sterility methods also reduce the risk of resistance development, as they do not rely on toxins that pests can evolve resistance to over time. Additionally, these methods can be used in conjunction with other pest management strategies, enhancing the overall effectiveness of integrated pest management

CHAPTER VII
BOTANICAL INSECT PEST MANAGEMENT

Ms.R.Ponmathi

*Assistant Professor, School of Agriculture,
Ponnaiyah Ramajayam Institute of Science and Technology, Tamil Nadu, India.*

Botanical insect pest management utilizes plant-derived substances to control insect pests, offering a natural and often environmentally friendly alternative to synthetic chemical pesticides. This approach leverages the natural insecticidal properties of certain plants, which have evolved various chemical defenses against herbivores. By harnessing these plant-based compounds, botanical pest management aims to reduce pest populations while minimizing ecological impact.

The primary advantage of botanical insect pest management lies in its reliance on natural substances that are generally less harmful to non-target organisms and the environment compared to conventional chemical pesticides. Botanical insecticides, such as pyrethrins from chrysanthemum flowers, neem oil from the neem tree, and rotenone from the roots of various plants, act on insects by interfering with their physiology or behavior. These substances can disrupt feeding, reproduction, or nervous system functions, leading to effective pest control.

Botanical insecticides often break down more quickly in the environment than synthetic chemicals, reducing the risk of long-term ecological damage and pesticide residues in food and water. Additionally, many botanical insecticides are derived from renewable plant sources, which contributes to their sustainability as pest management tools. This makes them suitable for integrated pest management (IPM) programs, where they can be used in conjunction with other methods to achieve comprehensive and environmentally responsible pest control.

Despite their advantages, the use of botanical insecticides also presents certain challenges. The effectiveness of these substances can vary depending on factors such as the specific pest species, application rates, and environmental conditions. Botanical insecticides may require more frequent applications compared to synthetic chemicals, as they can degrade more rapidly and may not provide residual control. Additionally, the development of resistance in pests, while less common than with synthetic pesticides, can still occur and may

CHAPTER VIII

HOST PLANT RESISTANCE IN PEST MANAGEMENT

Dr.M.Priyanga

Assistant Professor, School of Agriculture,

Ponnaiyah Ramajayam Institute of Science and Technology, Tamil Nadu, India.

Host plant resistance is a crucial component of pest management that involves utilizing plant varieties with inherent resistance traits to reduce the impact of pest populations. This strategy leverages the natural genetic variations in plants that confer resistance to specific pests, providing a sustainable and environmentally friendly approach to pest control. By incorporating resistant plant varieties into pest management programs, growers can effectively reduce pest damage and dependence on chemical pesticides.

The concept of host plant resistance is based on the ability of certain plants to withstand or deter pest attacks through various mechanisms. These mechanisms can be broadly categorized into two main types: **antibiosis** and **antixenosis**. **Antibiosis** refers to the negative impact of a plant on the growth, development, or survival of a pest. Plants exhibiting antibiosis may produce compounds that are toxic or deterrent to pests, thereby reducing their fitness and reproduction. **Antixenosis**, on the other hand, involves traits that make the plant less attractive or suitable for pests. These traits can include physical barriers, such as tough leaves or trichomes, or chemical repellents that discourage pests from feeding or laying eggs.

The development and deployment of resistant plant varieties involve several key processes, including **identification and characterization** of resistance traits, **breeding** for resistance, and **evaluation** of resistant varieties in field conditions. Identifying plant varieties with natural resistance to specific pests requires extensive screening and research. Once resistance traits are identified, they can be incorporated into breeding programs to develop new plant varieties with enhanced resistance. These resistant varieties are then evaluated under real-world conditions to ensure their effectiveness and adaptability in different environments.

The benefits of host plant resistance are substantial. Resistant plants can significantly reduce pest populations and damage, leading to lower crop losses and reduced need for chemical treatments. This contributes to more sustainable agricultural practices by decreasing reliance on synthetic pesticides and minimizing environmental pollution. Additionally, host

CHAPTER IX
MICROBIAL CONTROL AGENTS IN PEST MANAGEMENT

Dr.D.Jayakumar

*Assistant Professor, School of Agriculture,
Ponnaiyah Ramajayam Institute of Science and Technology, Tamil Nadu, India.*

Microbial Control Agents in Pest Management

Microbial control agents are natural enemies of pests that utilize microorganisms such as bacteria, fungi, viruses, and protozoa to manage pest populations. These agents are a crucial component of integrated pest management (IPM) strategies, offering an environmentally sustainable and effective alternative to chemical pesticides. By harnessing the biological activity of microorganisms, microbial control agents provide targeted pest management while minimizing the impact on non-target organisms and the environment.

1. Types of Microbial Control Agents

Microbial control agents are categorized based on the type of microorganism used and their mode of action against pests:

- **Bacterial Control Agents:** These include bacteria that produce toxins harmful to pests. The most well-known example is *Bacillus thuringiensis* (Bt), a soil bacterium that produces proteins toxic to certain insect larvae. Bt is used to control a variety of pests, including caterpillars of moths and butterflies, beetles, and flies. Different strains of Bt are specific to different pest groups, making it a versatile tool in pest management.
- **Fungal Control Agents:** Fungi that infect and kill pests are another important group of microbial control agents. For instance, *Beauveria bassiana* and *Metarhizium anisopliae* are entomopathogenic fungi that infect and kill a wide range of insect pests, including aphids, whiteflies, and thrips. These fungi penetrate the insect's exoskeleton, proliferate inside the host, and ultimately lead to its death.
- **Viral Control Agents:** Insect viruses, such as those from the family Baculoviridae, are used to control pests by causing specific viral infections. These viruses infect and kill insects, including lepidopteran pests like the cotton bollworm and the diamondback moth. Viral control agents are highly specific to their hosts, minimizing the impact on non-target species.
- **Protozoan Control Agents:** Protozoa are single-celled organisms that can infect and

CHAPTER X

CHEMICAL PEST CONTROL

Ms.K.Sharmitha

*Assistant Professor, School of Agriculture,
Ponnaiyah Ramajayam Institute of Science and Technology, Tamil Nadu, India.*

Chemical pest control involves the use of synthetic substances, commonly known as pesticides, to manage and reduce pest populations. These chemical agents are designed to target specific pests, disrupt their life cycles, and mitigate the damage they cause to crops, livestock, and human habitats. This introduction explores the principles of chemical pest control, its applications, benefits, and the challenges associated with its use.

Principles of Chemical Pest Control

Chemical pest control relies on the application of various classes of pesticides, each designed to affect specific pests through different mechanisms. These chemicals can be categorized into several groups based on their mode of action and target organisms:

- **Insecticides:** These target insects by interfering with their nervous systems, growth processes, or reproductive capabilities. Common insecticides include organophosphates, pyrethroids, and neonicotinoids.
- **Herbicides:** Used to control unwanted plants or weeds, herbicides can be selective or non-selective, affecting specific plant species or all vegetation, respectively.
- **Fungicides:** These control fungal pathogens that cause diseases in plants, preventing or mitigating fungal infections.
- **Rodenticides:** Designed to control rodent populations, these chemicals disrupt the physiological processes of rodents, leading to their death.

The effectiveness of chemical pest control depends on factors such as the correct identification of pests, appropriate pesticide selection, and precise application techniques. Pesticides are formulated to maximize their efficacy while minimizing impacts on non-target species and the environment.

Applications and Benefits

Chemical pest control offers several key advantages:

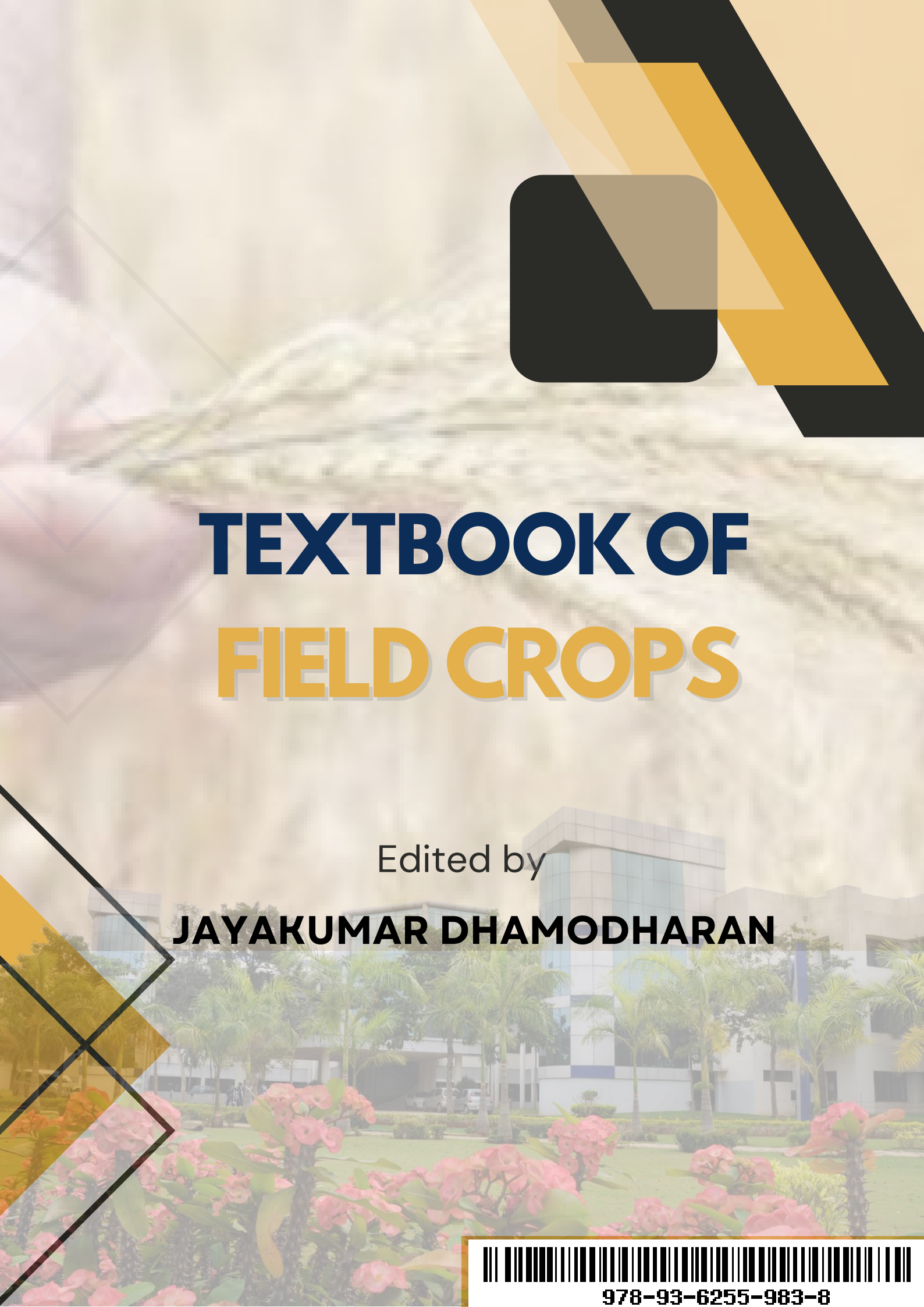

TEXTBOOK OF FIELD CROPS

Edited by

JAYAKUMAR DHAMODHARAN



978-93-6255-983-8

Textbook of Field Crops

Copyright © 2023 by Dr. D. Jayakumar

All rights reserved. No part of this book may be reproduced or transmitted in any form or by any means without written permission from the author.

ISBN:978-93-6255-983-8

Publisher: Ponnaiyah Ramajayam Institute of Science and Technology (PRIST)

TABLE OF CONTENT

| | |
|---|-----|
| Introduction..... | 8 |
| Chapter I: Production technology of cereals | 27 |
| DR. D. JAYAKUMAR | |
| Chapter II: Production technology of Millets..... | 48 |
| MS.K. SHARMITHA | |
| Chapter III: Production technology of pulses | 57 |
| MS.R. PONMATHI | |
| Chapter IV: Production technology of Oil Seeds..... | 72 |
| DR. A. UDHAYAKUMAR | |
| Chapter V: Production technology of Fibre Crops | 85 |
| DR. K. SIVA | |
| Chapter VI: Production technology of Sugar Crops | 109 |
| MS. C .K .AKSHAYA | |
| Chapter VII: Production technology of Green Manure Crops..... | 118 |
| DR. M. PRIYANGA | |
| Chapter VIII: Production technology of Fodder and Forage Crops..... | 125 |
| MS. D. GOKILAPPRIYA | |
| Chapter IX: Production technology of Tuber Crops..... | 133 |
| DR. D. NIROJA | |
| Chapter X: Production technology of Narcotics Crops..... | 148 |
| MS. G. PRIYA DHARSHINI | |

CHAPTER I
PRODUCTION TECHNOLOGY OF CEREALS

DR. D. JAYAKUMAR

Professor, School of Agriculture,

Ponnaiyah Ramajayam Institute of Science and Technology, Tamil Nadu, India.

The production technology of cereals involves a comprehensive approach that integrates soil preparation, seed selection, planting techniques, crop management, and harvesting practices to optimize yield and quality. Understanding these processes is essential for successful cereal cultivation.

Soil preparation is a critical first step in cereal production. It involves tilling the soil to improve its structure, aeration, and nutrient availability. Effective soil preparation also includes the application of fertilizers and organic amendments based on soil tests to ensure that the soil has the necessary nutrients for optimal crop growth.

Selecting the right seed variety is crucial for achieving high yields. Factors such as local climate, soil conditions, and pest resistance should guide the choice of cereal varieties. Quality seeds with high germination rates and disease resistance contribute to stronger plants and better harvests.

Planting techniques vary depending on the type of cereal and local conditions. Common methods include broadcasting, drilling, and row planting. The planting depth and spacing should be adjusted according to the cereal species and soil type to ensure good seed-to-soil contact and proper plant establishment.

Crop management throughout the growing season involves regular monitoring and maintenance. This includes managing water supply through irrigation or rainfall, controlling weeds through mechanical or chemical means, and monitoring for pests and diseases. Integrated pest management (IPM) strategies, which combine biological, cultural, and chemical controls, can help minimize damage and reduce reliance on pesticides.

CHAPTER II
PRODUCTION TECHNOLOGY OF MILLETS

MS.K. SHARMITHA

Assistant Professor, School of Agriculture,

Ponnaiyah Ramajayam Institute of Science and Technology, Tamil Nadu, India.

The production technology of millets encompasses a range of practices and techniques designed to maximize yield and ensure the quality of these hardy and nutritious crops. Millets are well-suited to diverse climates and soil types, making them an important staple in many regions. Effective production involves careful attention to soil preparation, seed selection, planting, crop management, and harvesting.

Soil preparation is essential for successful millet cultivation. Millets generally thrive in well-drained soils with good aeration. The soil should be prepared through adequate tillage to create a suitable seedbed. Incorporating organic matter and using appropriate fertilizers based on soil tests can enhance soil fertility and structure, providing a favorable environment for millet growth.

Choosing the right millet variety is crucial for optimizing production. Different millet species, such as pearl millet, finger millet, and foxtail millet, have varying requirements and benefits. Selecting varieties that are well-suited to local climatic conditions and resistant to pests and diseases can improve yield and resilience.

Planting techniques for millets involve considerations of seed depth, spacing, and planting time. Millets are often planted using methods such as broadcasting, drilling, or row planting. The planting depth typically ranges from 1 to 2 inches, depending on the millet type and soil conditions. Proper spacing between plants and rows ensures adequate light and nutrient availability for optimal growth.

Harvesting is a critical phase in millet production. Millets are typically harvested when the grains are fully mature and the moisture content is low. Timing the harvest correctly is essential to avoid losses due to shattering or spoilage. Modern harvesting equipment, such as combines or threshers, can improve efficiency and reduce labour requirements.

CHAPTER III
PRODUCTION TECHNOLOGY OF PULSES

MS.R. PONMATHI

Assistant Professor, School of Agriculture,

Ponnaiyah Ramajayam Institute of Science and Technology, Tamil Nadu, India.

The production technology of pulses involves a detailed process designed to maximize yield and quality while maintaining the health of the soil and environment. Pulses, including crops such as chickpeas, lentils, peas, and beans, are valuable for their high protein content and ability to enrich soil nitrogen. Effective production practices encompass soil preparation, seed selection, planting, crop management, and harvesting.

Proper soil preparation is essential for successful pulse cultivation. Pulses generally grow well in well-drained soils with good structure. The soil should be prepared through adequate tillage to create a suitable seedbed, which helps with seed germination and root development. Incorporating organic matter and applying fertilizers based on soil tests can enhance soil fertility and support healthy plant growth.

Choosing the right seed variety is crucial for optimizing pulse production. Different pulse species and varieties have varying requirements and benefits. Selecting seeds that are well-suited to the local climate, soil conditions, and resistant to pests and diseases can improve yield and resilience. High-quality seeds with good germination rates are essential for establishing a strong crop.

Planting techniques for pulses include considerations of seed depth, spacing, and timing. Pulses are typically planted using methods such as drilling or row planting. The planting depth usually ranges from 1 to 2 inches, depending on the pulse type and soil conditions. Proper spacing between plants and rows ensures adequate light, airflow, and nutrient availability, which are critical for optimal growth and reducing competition.

Harvesting pulses at the right time is critical to prevent losses and ensure quality. Pulses are typically harvested when the seeds are fully mature and the moisture content is low. Timing the harvest to avoid losses from shattering or spoilage is essential.

CHAPTER IV
PRODUCTION TECHNOLOGY OF OIL SEEDS

DR. A. UDHAYAKUMAR

Professor, School of Agriculture,

Ponnaiyah Ramajayam Institute of Science and Technology, Tamil Nadu, India.

The production technology of oilseeds encompasses a series of practices designed to optimize yield and ensure the quality of oilseed crops, which include soybean, sunflower, canola, and safflower. Effective production involves meticulous attention to soil preparation, seed selection, planting, crop management, and harvesting.

Soil preparation is fundamental for successful oilseed cultivation. Oilseeds typically grow best in well-drained soils with good fertility. Adequate tillage is required to create a suitable seedbed, which enhances seed germination and root development. The incorporation of organic matter and the application of fertilizers, based on soil tests, can improve soil structure and nutrient availability, providing an optimal environment for crop growth.

Selecting the appropriate oilseed variety is crucial. Different oilseed crops have varying requirements and characteristics. Choosing varieties that are well-suited to the local climate and soil conditions, and that are resistant to pests and diseases, can significantly impact yield and crop health. High-quality seeds with strong germination potential are essential for establishing a robust crop.

Planting techniques for oilseeds involve considerations of seed depth, spacing, and timing. Oilseeds are generally planted using methods such as drilling or row planting. The planting depth usually ranges from 1 to 2 inches, depending on the crop type and soil conditions. Proper spacing between plants and rows ensures adequate light, airflow, and nutrient availability, which are important for healthy growth and yield optimization.

Crop management practices during the growing season are crucial for maintaining crop health and maximizing yield. While oilseeds generally require moderate water supply, irrigation may be necessary during dry periods to ensure consistent growth. Weed control can be achieved through mechanical methods or selective herbicides.

CHAPTER V

PRODUCTION TECHNOLOGY OF FIBER CROPS

DR. K. SIVA

Assistant Professor, School of Agriculture,

Ponnaiyah Ramajayam Institute of Science and Technology, Tamil Nadu, India.

The production technology of fiber crops involves a range of practices designed to maximize yield and quality while ensuring the sustainability of cultivation. Fiber crops, such as cotton, flax, jute, and hemp, are valued for their fibers, which are used in textiles, construction, and other industries. Effective production practices encompass soil preparation, seed selection, planting, crop management, and harvesting.

Soil preparation is a critical step for successful fiber crop cultivation. Most fiber crops grow best in well-drained soils with good fertility. Adequate tillage is necessary to create a suitable seedbed, which helps with seed germination and root establishment. Incorporating organic matter and applying fertilizers based on soil tests can improve soil structure and nutrient availability, providing a favorable environment for crop growth.

Selecting the right crop variety is crucial for optimizing fiber production. Different fiber crops have varying requirements and characteristics. Choosing varieties that are well-adapted to local climate and soil conditions, and that are resistant to pests and diseases, can significantly impact yield and quality. High-quality seeds with good germination potential are essential for establishing a strong crop.

Planting techniques for fiber crops involve considerations of seed depth, spacing, and timing. Fiber crops are typically planted using methods such as broadcasting, drilling, or row planting. The planting depth usually ranges from 1 to 2 inches, depending on the crop type and soil conditions. Proper spacing between plants and rows ensures adequate light, airflow, and nutrient availability, which are critical for healthy growth and fiber development.

Crop management practices during the growing season are essential for maintaining crop health and maximizing yield. Most fiber crops require moderate to adequate water supply, and irrigation may be necessary during dry periods to support growth. Weed control can be achieved through mechanical methods or selective herbicides.

CHAPTER VI
PRODUCTION TECHNOLOGY OF SUGAR CROPS

MS. C. K. AKSHAYA

Assistant Professor, School of Agriculture,

Ponnaiyah Ramajayam Institute of Science and Technology, Tamil Nadu, India.

The production technology of sugar crops involves a series of practices and techniques aimed at maximizing yield and ensuring the quality of crops such as sugarcane and sugar beets. These crops are crucial for the production of sugar and other by-products. Effective production encompasses soil preparation, seed or planting material selection, planting, crop management, and harvesting.

Soil preparation is essential for the successful cultivation of sugar crops. Both sugarcane and sugar beets thrive in well-drained soils with good fertility. The soil should be prepared through adequate tillage to create a suitable seedbed or planting area. Incorporating organic matter and applying fertilizers based on soil tests can enhance soil structure and nutrient availability, providing an optimal environment for crop growth.

Choosing the right variety of sugar crop is crucial for achieving high production. For sugarcane, varieties should be selected based on local climatic conditions, soil type, and resistance to pests and diseases. Similarly, for sugar beets, selecting varieties suited to the local environment and resistant to diseases can improve yield and quality. High-quality planting material, whether seeds or seedlings, is essential for establishing a strong crop.

Planting techniques for sugar crops vary depending on the type. Sugarcane is typically planted using cuttings or setts, which are sections of the cane stalk. The cuttings are planted in furrows or trenches at a depth of 2 to 4 inches. Sugar beets are generally planted using seeds sown directly into the soil at a depth of 1 to 2 inches. Proper spacing between rows and plants is important to ensure adequate light, airflow, and nutrient availability.

Crop management practices during the growing season are vital for maintaining crop health and maximizing yield. Sugar crops often require substantial water supply, and irrigation may be necessary during dry periods.

CHAPTER VII

PRODUCTION TECHNOLOGY OF GREEN MANURE CROPS

DR. M. PRIYANGA

Assistant Professor, School of Agriculture,

Ponnaiyah Ramajayam Institute of Science and Technology, Tamil Nadu, India.

The production technology of green manure crops involves a series of practices aimed at optimizing the benefits these crops provide to soil health and fertility. Green manure crops, which include legumes like clover, vetch, and peas, as well as non-legumes like rye and mustard, are grown primarily to be incorporated into the soil to improve soil structure, nutrient content, and overall fertility. Effective production of green manure crops encompasses soil preparation, seed selection, planting, crop management, and incorporation.

Soil preparation is the first step in growing green manure crops. The soil should be well-drained and well-aerated, with good structure to support healthy root development. Adequate tillage is necessary to create a suitable seedbed, which ensures good seed-to-soil contact and facilitates germination. Incorporating organic matter and ensuring proper soil pH can further enhance soil conditions.

Selecting the right green manure crop is crucial for maximizing benefits. The choice of crop depends on factors such as soil type, climate, and the specific benefits desired. Leguminous green manures, like clover and vetch, are valued for their ability to fix atmospheric nitrogen into the soil, while non-leguminous options, like rye and mustard, can improve soil structure and suppress weeds. Choosing varieties suited to the local conditions and intended use will optimize the effectiveness of the green manure.

Planting techniques for green manure crops include considerations of seed depth, spacing, and timing. Most green manure crops are planted using methods such as broadcasting or drilling. The planting depth typically ranges from 0.5 to 2 inches, depending on the crop type and soil conditions. Proper spacing between rows and plants ensures adequate light and nutrient availability, which is important for healthy growth and effective green manure.

CHAPTER VIII

PRODUCTION TECHNOLOGY OF FODDER AND FORAGE CROPS

MS. D. GOKILAPPRIYA

Assistant Professor, School of Agriculture,

Ponnaiyah Ramajayam Institute of Science and Technology, Tamil Nadu, India.

The production technology of fodder and forage crops involves a series of practices aimed at maximizing yield, quality, and sustainability for livestock feed. Fodder and forage crops, including alfalfa, clover, grasses (such as timothy and ryegrass), and silage crops (such as maize and sorghum), are essential for providing nutritious feed for livestock. Effective production encompasses soil preparation, seed or planting material selection, planting, crop management, and harvesting.

Soil preparation is fundamental for successful fodder and forage crop cultivation. These crops typically require well-drained soils with good fertility. The soil should be prepared through appropriate tillage to create a suitable seedbed. Incorporating organic matter and applying fertilizers based on soil tests can enhance soil structure and nutrient availability, providing an optimal environment for crop growth.

Selecting the right crop variety is crucial for optimizing production. Different fodder and forage crops have varying requirements and benefits. For legumes like alfalfa and clover, which are valued for their high protein content and nitrogen-fixing abilities, choosing varieties suited to local climate and soil conditions is essential. For grass species, selecting varieties with high yield potential and disease resistance can improve productivity. High-quality seeds or planting material are vital for establishing a robust crop.

Planting techniques for fodder and forage crops include considerations of seed depth, spacing, and timing. Seeds are typically sown using methods such as broadcasting, drilling, or row planting. The planting depth usually ranges from 0.5 to 2 inches, depending on the crop type and soil conditions. Proper spacing between rows and plants ensures adequate light, airflow, and nutrient availability, which are important for healthy growth and high forage quality.

CHAPTER IX
PRODUCTION TECHNOLOGY OF TUBER CROPS

DR. D. NIROJA

Assistant Professor, School of Agriculture,

Ponnaiyah Ramajayam Institute of Science and Technology, Tamil Nadu, India.

The production technology of tuber crops involves a series of practices aimed at optimizing yield and ensuring the quality of crops such as potatoes, sweet potatoes, yams, and taro. These crops are valued for their starchy tubers, which serve as essential food sources. Effective production practices encompass soil preparation, seed or planting material selection, planting, crop management, and harvesting.

Soil preparation is crucial for successful tuber crop cultivation. Tubers generally thrive in well-drained soils with good fertility. The soil should be prepared through thorough tillage to create a loose, friable seedbed that supports tuber development. Incorporating organic matter and applying fertilizers based on soil tests can enhance soil structure and nutrient availability, providing an optimal growing environment.

Selecting the right variety of tuber crop is essential for maximizing production. Different tuber crops have varying requirements and benefits. For example, potatoes come in many varieties, each suited to different climatic conditions and uses, such as boiling, baking, or frying. Choosing varieties adapted to the local environment and resistant to pests and diseases can significantly impact yield and quality. High-quality seed tubers or planting material are crucial for establishing a strong crop.

Planting techniques for tuber crops include considerations of planting depth, spacing, and timing. Tuber crops are typically planted using methods such as trench planting for potatoes or mounding for sweet potatoes. The planting depth usually ranges from 2 to 4 inches, depending on the crop type and soil conditions. Proper spacing between plants and rows ensures adequate light, airflow, and nutrient availability, which are critical for healthy growth and tuber development.

CHAPTER X

PRODUCTION TECHNOLOGY OF NARCOTICS CROPS

MS. G. PRIYA DHARSHINI

Assistant Professor, School of Agriculture,

Ponnaiyah Ramajayam Institute of Science and Technology, Tamil Nadu, India.

The production technology of narcotic crops involves specialized practices designed to optimize yield and ensure the quality of plants used for their psychoactive properties. Narcotic crops, such as opium poppy (*Papaver somniferum*), coca (*Erythroxylum coca*), and cannabis (*Cannabis sativa*), are cultivated under strict regulatory frameworks due to their potential for misuse. Effective production practices encompass soil preparation, seed or planting material selection, planting, crop management, and harvesting.

Soil Preparation: Proper soil preparation is critical for the successful cultivation of narcotic crops. These plants generally require well-drained, fertile soils. The soil should be prepared through thorough tillage to create a fine seedbed that supports good root development. Organic matter should be incorporated, and soil fertility should be enhanced based on soil testing to provide a nutrient-rich environment conducive to plant growth.

Seed or Planting Material Selection: Choosing the right variety and quality of planting material is essential for optimizing production. For opium poppy, selecting varieties with high latex yield and suitable for local climate conditions is crucial. In the case of coca, varieties are chosen based on alkaloid content and resistance to pests. For cannabis, strains are selected based on the desired cannabinoid profile and growth characteristics. High-quality seeds or seedlings ensure robust plant establishment and optimal yield.

Planting Techniques: Planting techniques vary depending on the crop. Opium poppy is typically planted using seeds sown in rows or broadcasted over the prepared soil. The seeds are generally sown at a depth of about 0.5 inches. Coca is usually planted from seedlings or cuttings in rows, with proper spacing to ensure good growth and air circulation. Cannabis is often grown from seeds or clones, with planting depth and spacing adjusted based on the growth habit and desired plant size.

ELEMENTS OF IRRIGATION MANAGEMENT

EDITED BY

UDAYAKUMAR AYYAVOO



978-93-6255-116-0

Elements of Irrigation Management

Copyright © 2023 by Dr. A. Udayakumar

All rights reserved. No part of this book may be reproduced or transmitted in any form or by any means without written permission from the author.

ISBN: 978-93-6255-116-0

Publisher: Ponnaiyah Ramajayam Institute of Science and Technology (PRIST)

TABLE OF CONTENT

| | |
|---|-----|
| Introduction..... | 6 |
| Chapter I: Introduction of irrigation management | 25 |
| MS. R. PONMATHI | |
| Chapter II: Water resource and irrigation development | 41 |
| DR. A. UDHAYAKUMAR | |
| Chapter III: Soil water and plant water relationship | 56 |
| MS. N. DHIVYA PRIYA | |
| Chapter IV: Methods of irrigation and drainage..... | 78 |
| MRS. S.R.RAJAM | |
| Chapter V: Special Methods of Irrigation | 92 |
| DR. K. SIVA | |
| Chapter VI: Measurement of irrigation water | 109 |
| MS. C .K .AKSHAYA | |
| Chapter VII: Estimation of Soil Moisture constraints | 118 |
| MS.K.SHALINI | |
| Chapter VIII: Irrigation efficiency | 123 |
| DR. B. VIBITHA BALA | |
| Chapter IX: Drainage | 135 |
| MS. M. JASMINE | |
| Chapter X: Water Management Practices | 148 |
| MS. G. GAYATHRI | |

CHAPTER I
INTRODUCTION OF IRRIGATION MANAGEMENT

MS. R. PONMATHI

Assistant Professor, School of Agriculture,

Ponnaiyah Ramajayam Institute of Science and Technology, Tamil Nadu, India.

Irrigation management is a crucial aspect of modern agriculture and water resource management, focused on optimizing the application of water to crops and other plants. Its primary goal is to enhance crop yield, improve water efficiency, and ensure sustainable water use. Effective irrigation management involves understanding the interactions between water, soil, and plants and applying this knowledge to achieve optimal growth conditions.

Water Requirements of Crops: Different crops have varying water needs depending on their growth stage, climate, and soil type. Understanding these requirements helps in determining how much and how often to irrigate. Soil type, texture, and structure influence water retention and movement. Soils with high clay content, for instance, retain more water but may drain more slowly compared to sandy soils. **Climate and Weather Conditions:** Temperature, humidity, and rainfall patterns significantly impact irrigation needs. Accurate weather forecasting and climate analysis are essential for planning irrigation schedules.

Large, slow-moving masses of ice and snow that store a significant portion of the world's freshwater. They release water gradually as they melt, contributing to river flows and groundwater recharge. The upper surface of the groundwater zone, below which the soil or rock is saturated with water. The level of the water table can vary based on factors like rainfall and groundwater extraction. Large bodies of saltwater that cover about 71% of the Earth's surface. Oceans play a critical role in climate regulation, nutrient cycling, and supporting marine ecosystems. Effective scheduling involves timing water applications to match crop needs and soil moisture levels. Techniques such as irrigation calendars, moisture sensors, and weather-based controllers help optimize timing and frequency.

Advanced technologies, including automated controllers, remote sensing, and data analytics, enhance precision and efficiency. Automation systems help regulate water application based on real-time data and reduce labor requirements.

CHAPTER II
WATER RESOURCE AND IRRIGATION DEVELOPMENT

DR. A. UDHAYAKUMAR

Professor, School of Agriculture,

Ponnaiyah Ramajayam Institute of Science and Technology, Tamil Nadu, India.

Water resources are essential to life and fundamental to the functioning of ecosystems and human societies. They encompass the vast array of water forms available on Earth, including rivers, lakes, groundwater, glaciers, and atmospheric water. Efficient management and sustainable use of these resources are critical for ensuring their availability for future generations, supporting agriculture, industry, and meeting the needs of a growing global population.

Water resources sustain diverse ecosystems, from freshwater rivers and wetlands to marine environments. Healthy aquatic ecosystems provide habitats for wildlife, support biodiversity, and contribute to ecological balance. Water is vital for agriculture, which relies on it for crop irrigation, livestock watering, and soil management. Efficient water use in agriculture supports food security and rural livelihoods, particularly in regions with variable or scarce water supplies. **Human Consumption and Health:** Access to clean and safe drinking water is crucial for human health and well-being. Adequate water supplies are essential for sanitation, hygiene, and preventing waterborne diseases. **Economic Development:** Water resources are integral to various industrial processes, including manufacturing, energy production, and mining. They also support recreational activities, tourism, and transportation through rivers and lakes.

Many regions face water scarcity due to factors such as population growth, over-extraction, and climate change. Effective management strategies are needed to address the gap between water demand and availability. Water pollution from agricultural runoff, industrial discharges, and improper waste disposal threatens water quality. Contaminated water sources pose risks to health, ecosystems, and economies. Climate change impacts water resources by altering precipitation patterns, increasing the frequency of extreme weather events, and affecting the availability of freshwater. Excessive withdrawal of water for various uses can deplete natural sources, reduce river flows, and affect groundwater levels. Sustainable extraction practices are crucial to prevent long-term resource depletion.

CHAPTER III

SOIL WATER AND PLANT WATER RELATIONSHIP

MS. N. DHIVYA PRIYA

Assistant Professor, School of Agriculture,

Ponnaiyah Ramajayam Institute of Science and Technology, Tamil Nadu, India.

The relationship between soil, water, and plants is a fundamental aspect of agriculture and environmental science. Understanding this dynamic interplay is crucial for optimizing plant growth, ensuring agricultural productivity, and managing water resources effectively. This relationship involves how water moves through the soil, how it is available to plants, and how plants interact with their water environment to sustain their physiological functions.

Soil moisture is a critical factor in determining how much water is available to plants. It is influenced by soil properties such as texture, structure, and organic content. Different soil types retain and transmit water differently; for example, sandy soils drain quickly and have lower water-holding capacity, while clay soils retain more water but may have slower drainage. Soil water availability is determined by the soil's field capacity (the amount of water it can hold after excess water has drained) and its wilting point (the moisture level below which plants cannot extract water). Effective soil management practices, such as adding organic matter, can enhance water retention and improve overall soil health.

Infiltration is the process by which water enters the soil surface, while percolation refers to the movement of water through the soil profile. These processes affect the rate at which water reaches plant roots and influences groundwater recharge. Plants absorb water through their roots from the soil, which is essential for various physiological processes including nutrient uptake, photosynthesis, and growth. The efficiency of water uptake depends on root health, soil moisture levels, and the plant's water demands. Transpiration is the loss of water from plants to the atmosphere, primarily through leaves. It helps regulate plant temperature and facilitates nutrient transport. Evaporation, the loss of water from soil and surfaces, also impacts the amount of moisture available to plants. Together, transpiration and evaporation are key components of the hydrological cycle and influence soil moisture levels.

CHAPTER IV
METHODS OF IRRIGATION

MRS. S.R. RAJAM

Assistant Professor, School of Agriculture,

Ponnaiyah Ramajayam Institute of Science and Technology, Tamil Nadu, India.

Irrigation and drainage are critical components of water management in agriculture and land use. They help optimize water use for crop growth and manage excess water to prevent waterlogging and soil erosion. Here's an overview of various methods used in irrigation and drainage:

Surface Irrigation: Furrow Irrigation: Water is applied in furrows or small channels between rows of crops. It's suitable for row crops and can be either gravity-fed or pumped. Basin Irrigation: Fields are divided into small basins or plots that are flooded with water. It's commonly used for crops like rice. Border Irrigation: Land is divided into long, narrow strips bordered by low ridges. Water flows down the borders and infiltrates into the soil. Flood Irrigation: Water is applied uniformly across the field, often by flooding the entire area. This method is less efficient and can lead to water wastage and soil erosion.

Subsurface irrigation involves burying irrigation tubes or pipes below the soil surface to deliver water directly to the root zone. This method: **Reduces Evaporation:** Since water is applied below the surface, it minimizes water loss through evaporation and reduces weed growth. **Improves Water Use Efficiency:** It provides a consistent moisture supply directly to the plant roots, enhancing growth and reducing water wastage.

Manual Irrigation: Involves the use of hand tools such as watering cans or hoses. This method is labour-intensive and suitable for small-scale or garden irrigation. **Gravity-Fed Systems:** Utilize natural gravitational forces to move water from a higher source to the fields. Simple and cost-effective, these systems are common in regions with ample water supply and gentle slopes.

CHAPTER V

SPECIAL METHODS OF IRRIGATION

DR. K. SIVA

Assistant Professor, School of Agriculture,

Ponnaiyah Ramajayam Institute of Science and Technology, Tamil Nadu, India.

Special methods of irrigation are advanced techniques designed to enhance water use efficiency, improve crop yields, and address specific challenges in agriculture. These methods often incorporate technology and innovative practices to achieve precise water application and conservation. Here's an overview of some notable special irrigation methods:

Drip irrigation delivers water directly to the plant roots through a network of tubes and emitters. **Precision Watering:** Water is supplied in small, controlled amounts, reducing evaporation and runoff. It is ideal for row crops, orchards, and greenhouses. **Water Conservation:** Drip irrigation minimizes water waste and improves water use efficiency by targeting the root zone directly. **Enhanced Growth:** By providing consistent moisture, drip irrigation promotes healthy plant growth and can lead to higher yields.

Sprinkler irrigation mimics natural rainfall by spraying water over the crops. It includes several types: **Center Pivot Systems:** Large, rotating sprinklers mounted on wheeled towers cover circular areas of the field. This system is effective for large-scale farms and ensures uniform water distribution. **Fixed and Portable Sprinklers:** Fixed systems are stationary, while portable systems can be moved between different fields. Both types are suitable for various crop types and field sizes. **Gun and Mini-Sprinklers:** Gun sprinklers cover large areas with high water flow, while mini-sprinklers provide fine mist for smaller areas or delicate plants.

Sub-surface irrigation involves burying irrigation tubes or pipes below the soil surface to deliver water directly to the root zone. This method: **Reduces Evaporation:** Since water is applied below the surface, it minimizes water loss through evaporation and reduces weed growth. It involves the use of hand tools such as watering cans or hoses. This method is labour-intensive and suitable for small-scale or garden irrigation.

CHAPTER VI
MEASUREMENT OF IRRIGATION WATER
MS. C. K. AKSHAYA

Assistant Professor, School of Agriculture,

Ponnaiyah Ramajayam Institute of Science and Technology, Tamil Nadu, India.

The measurement of irrigation water is critical for optimizing crop growth, conserving resources, and ensuring sustainable agricultural practices. It involves quantifying the amount of water applied to crops, managing water distribution efficiently, and minimizing wastage. This one-page overview highlights the key methods and tools used for measuring irrigation water, their benefits, and their applications.

Accurate measurement ensures that water is applied precisely according to crop needs, reducing over-application and under-application. This optimizes water use efficiency, essential for conserving water resources, especially in water-scarce regions. Proper water measurement helps maintain optimal soil moisture levels, promoting healthy plant growth and maximizing crop yields. It prevents water stress and ensures that plants receive consistent moisture. Effective measurement reduces unnecessary water use, leading to cost savings in terms of water supply and energy required for irrigation. It also minimizes potential losses from water wastage and inefficiencies. Accurate measurement helps prevent negative environmental impacts such as soil erosion, runoff, and waterlogging. It supports sustainable irrigation practices that protect soil health and reduce pollution. Flow meters measure the rate of water flow through irrigation systems, providing real-time data on water usage. Types include:

Benefits: Flow meters enable precise control of water application and provide valuable data for monitoring and managing irrigation efficiency. **Water Measuring Devices** These devices gauge the volume of water applied during irrigation. Accurate measurement of irrigation water is essential for optimizing agricultural practices, conserving resources, and protecting the environment. By utilizing flow meters, water measuring devices, soil moisture sensors, water balance methods, and smart irrigation systems, farmers and water managers can achieve precise water application, improve crop yields, and promote sustainable water use. Effective measurement practices support efficient irrigation, cost savings, and environmental stewardship, contributing to a more resilient and productive agricultural system.

CHAPTER VII

ESTIMATION OF SOIL MOISTURE CONSTRAINTS

MS. K. SHALINI

Assistant Professor, School of Agriculture,

Ponnaiyah Ramajayam Institute of Science and Technology, Tamil Nadu, India.

Estimating soil moisture constraints is pivotal for effective land and water management in agriculture. Soil moisture, the amount of water present in the soil, directly influences plant growth, crop yields, and overall agricultural productivity. Understanding soil moisture constraints involves assessing how variations in moisture levels impact plant health, irrigation requirements, and soil management practices. This introduction provides an overview of the importance, methods, and challenges associated with estimating soil moisture constraints.

Optimizing Crop Growth: Soil moisture is crucial for nutrient uptake and physiological processes in plants. Adequate moisture ensures healthy plant growth, enhances crop yields, and reduces stress-induced damage. Estimating soil moisture constraints helps in providing the right amount of water to meet plant needs throughout their growth stages. **Efficient Irrigation Management:** Accurate estimation of soil moisture helps in scheduling irrigation efficiently, preventing over- or under-irrigation. This leads to better water management, reduced waste, and cost savings. It also minimizes the risk of waterlogging or drought stress.

Improving Soil Health: Soil moisture influences soil structure, nutrient availability, and microbial activity. Proper moisture management helps maintain soil health, prevent erosion, and enhance soil fertility. Estimating soil moisture constraints supports practices that improve soil quality and sustainability. **Environmental Protection:** Managing soil moisture effectively reduces the environmental impact of irrigation practices. By preventing excessive runoff, erosion, and water pollution, proper moisture estimation contributes to environmental conservation and sustainable land use.

CHAPTER VIII

IRRIGATION EFFICIENCY

DR. B. VIBITHA BALA

Assistant Professor, School of Agriculture,

Ponnaiyah Ramajayam Institute of Science and Technology, Tamil Nadu, India.

Irrigation efficiency is a crucial aspect of modern agriculture, impacting water usage, crop yield, and environmental sustainability. It refers to how effectively water applied to crops is utilized by plants, minimizing wastage and ensuring optimal growth conditions. Efficient irrigation practices are essential for conserving water resources, particularly in regions prone to drought or with limited water availability.

Surface Irrigation: This traditional method involves distributing water over the soil surface through channels or furrows. While simple and low-cost, its efficiency can vary depending on the field's topography and soil type. **Drip Irrigation:** Known for its high efficiency, drip irrigation delivers water directly to the plant roots through a network of tubes and emitters. This method reduces evaporation and runoff, making it ideal for water-scarce regions and high-value crops. **Sprinkler Irrigation:** Mimicking natural rainfall, this system disperses water through overhead pipes and sprinklers. It offers better control over water distribution compared to surface irrigation but can suffer from evaporation and wind drift.

Irrigation efficiency can be quantified using several metrics, including: **Application Efficiency (AE):** The ratio of the amount of water that effectively infiltrates into the root zone to the total amount of water applied. **Distribution Uniformity (DU):** Measures how evenly water is distributed across the field, with higher values indicating more uniform coverage. **Water Use Efficiency (WUE):** The ratio of crop yield to the amount of water used, reflecting how well water contributes to plant growth.

Best Practices for Enhancing Efficiency: **Soil Moisture Monitoring:** Regularly check soil moisture levels to tailor irrigation schedules and amounts to actual crop needs. **System Maintenance:** Ensure irrigation systems are well-maintained to prevent leaks, clogs, and inefficiencies. **Technology Integration:** Utilize advanced technologies such as weather-based controllers, soil moisture sensors, and precision irrigation systems to optimize water use.

CHAPTER IX

DRAINAGE

MS. M. JASMINE

Assistant Professor, School of Agriculture,

Ponnaiyah Ramajayam Institute of Science and Technology, Tamil Nadu, India.

In agriculture, effective water management is key to achieving optimal crop growth and productivity, and drainage plays a vital role in this balance. While irrigation is crucial for providing crops with necessary moisture, drainage systems are essential for managing excess water, preventing issues like waterlogging, and maintaining healthy soil conditions.

Waterlogging occurs when excess moisture saturates the soil, depriving plant roots of essential oxygen. This can lead to root rot and other diseases, adversely affecting crop health and reducing yields. Additionally, poorly drained soils can suffer from compaction and erosion, further compromising plant growth. By effectively managing excess water, drainage systems help maintain soil structure and enhance aeration, both of which are critical for healthy root development and nutrient uptake.

Effective drainage also helps mitigate soil salinity. In regions where high evaporation rates can lead to salt accumulation, proper drainage systems can flush away these salts, preventing soil salinization and preserving soil fertility. By keeping the soil in optimal condition, drainage contributes to improved crop yields and healthier plants.

There are several types of drainage systems, each suited to different soil conditions and water management needs. Surface drainage involves the removal of excess water from the soil surface through channels or ditches, which can help direct runoff away from fields.

Subsurface drainage, on the other hand, utilizes buried pipes or tiles to remove water from below the soil surface, particularly in clayey soils prone to waterlogging. Controlled drainage systems allow for the regulation of the water table, balancing water retention and drainage to enhance nutrient management and reduce runoff.

Implementing effective drainage requires a thorough understanding of soil characteristics and water table levels.

CHAPTER X

WATER MANAGEMENT PRACTICES

MS. G. GAYATHRI

Assistant Professor, School of Agriculture,

Ponnaiyah Ramajayam Institute of Science and Technology, Tamil Nadu, India.

Effective water management practices are crucial for optimizing water use, ensuring sustainable agricultural practices, and conserving valuable resources. These practices encompass a range of strategies and techniques designed to maximize water efficiency, reduce waste, and address the varying needs of different crops and soil types.

One fundamental approach is the adoption of water conservation techniques. These can include methods such as scheduling irrigation to match crop water requirements, utilizing mulch to reduce evaporation, and implementing rainwater harvesting systems. Rainwater harvesting involves collecting and storing rainwater for later use, which can supplement irrigation needs and reduce reliance on other water sources.

Integrated Water Resource Management (IWRM) is another critical strategy. IWRM involves coordinating the management of water, land, and related resources to maximize economic and social benefits while minimizing environmental impacts. This approach requires the collaboration of various stakeholders, including farmers, policymakers, and water resource managers, to create comprehensive plans that address the needs of all users and the environment.

In addition to these techniques, soil management plays a significant role in water management. Practices such as soil conservation, proper tillage, and the use of cover crops can improve soil structure and increase its water-holding capacity. This helps to retain moisture and reduce runoff, making water use more efficient.

Advanced technologies also contribute to effective water management. Smart irrigation systems, for example, use sensors and weather data to adjust irrigation schedules based on real-time conditions.

MICROBIAL ECOLOGY: NURTURING AGRICULTURAL RESILIENCE AND SUSTAINABILITY

Edited by

ARUN KUMAR RAMU



978-93-6255-494-9

Microbial Ecology: Nurturing Agricultural Resilience and Sustainability

Copyright © 2023 by Arun Kumar Ramu

All rights reserved. No part of this book may be reproduced or transmitted in any form or by any means without written permission from the author.

ISBN: 978-93-6255-494-9

Publisher: Ponnaiyah Ramajayam Institute of Science and Technology (PRIST)

TABLE OF CONTENT

| | |
|---|-----|
| Introduction..... | 6 |
| Chapter I: Cultivating Connections: Microbes, Roots, and Nutrient Cycling | 25 |
| Ms. Gayathri Ganesan | |
| Chapter II: Eco-Friendly Farming: Microbial Innovations for Sustainability | 45 |
| Ponmathi Ramasamy | |
| Chapter III: Microbial Symphony: Harmonizing Crop Health and Productivity | 69 |
| Sharmitha Krishnakumar | |
| Chapter IV: The Microbial Matrix: Decoding Nature's Agricultural Blueprint | 89 |
| Niroja Dharmalingam, | |
| Chapter V: Innovation Underground: Exploring Microbial Mysteries in Agriculture | 118 |
| Sharmitha Krishnakumar | |
| Chapter VI: Harnessing microbial diversity for soil health and crop productivity..... | 134 |
| Ms.D.Gokilappriya | |
| Chapter VII: Innovative microbial strategies for sustainable agricultural practices.... | 145 |
| Dr.M.Priyanga | |
| Chapter VIII: Soil Microbiome Diversity and Function..... | 155 |
| Dr.S.Vigneshwaran | |
| Chapter IX: Mycorrhizal Fungi and Plant Relationships..... | 170 |
| Dr.K.C.Sivabalan | |
| Chapter X: Nitrogen Fixation and Rhizobial Symbiosis..... | 180 |
| Ms.G. Priyadharshini | |
| REFERENCE: | |

CHAPTER I

CULTIVATING CONNECTIONS: MICROBES, ROOTS, AND NUTRIENT CYCLING

MS. GAYATHRI GANESAN

Assistant Professor, School of Agriculture,

Ponnaiyah Ramajayam Institute of Science and Technology, Tamil Nadu, India

In the realm of agriculture and natural ecosystems, the interconnected roles of microbes, roots, and nutrient cycling form a crucial triad that sustains plant health and soil fertility. At the core of this relationship are soil microbes—bacteria, fungi, and other microorganisms—that act as nature’s decomposers. These microbes break down organic matter, such as dead plant material and animal waste, transforming it into simpler compounds. This decomposition process releases essential nutrients like nitrogen, phosphorus, and potassium into the soil, making them available for plant uptake.

Roots play a pivotal role in this nutrient exchange. They not only anchor plants but also interact closely with soil microbes through a process known as the rhizosphere effect. This interaction benefits both parties: roots exude organic compounds that serve as food for microbes, while microbes enhance the plant's access to nutrients by breaking down complex substances in the soil. For example, mycorrhizal fungi, a type of soil fungus, form symbiotic relationships with plant roots, extending their hyphae into the soil to access nutrients that roots alone might not reach.

Nutrient cycling is the overarching process that binds these elements together. It describes how nutrients are recycled within the ecosystem through various biological, chemical, and physical processes. Microbes are central to this cycle, decomposing organic matter and converting nutrients into forms that plants can readily absorb. This cycle ensures that nutrients are continually replenished, maintaining soil fertility and supporting plant growth.

The cultivation practices employed by farmers and land managers can significantly influence this intricate system. Practices such as crop rotation, cover cropping, and reduced tillage can enhance microbial activity and improve nutrient cycling efficiency, leading to healthier soils and more resilient crops.

CHAPTER II

ECO-FRIENDLY FARMING: MICROBIAL INNOVATIONS FOR SUSTAINABILITY

PONMATHI RAMASAMY

Assistant Professor, School of Agriculture,

Ponnaiyah Ramajayam Institute of Science and Technology, Tamil Nadu, India

Eco-friendly farming is increasingly embracing microbial innovations as a cornerstone for sustainable agriculture. At the heart of this movement is the recognition that soil microbes—such as bacteria, fungi, and other microorganisms—play a pivotal role in maintaining soil health and fertility. These tiny organisms are instrumental in processes like nutrient cycling, organic matter decomposition, and disease suppression, which are essential for growing healthy crops without relying heavily on synthetic inputs.

Microbial innovations offer promising solutions for enhancing soil productivity while minimizing environmental impact. For example, the use of beneficial microbes, like mycorrhizal fungi and nitrogen-fixing bacteria, can improve nutrient uptake by plants, reduce the need for chemical fertilizers, and enhance soil structure. Mycorrhizal fungi extend the root system's reach, facilitating better access to nutrients and water, while nitrogen-fixing bacteria convert atmospheric nitrogen into a form that plants can use, thereby reducing the reliance on synthetic nitrogen fertilizers.

Additionally, microbial inoculants and biofertilizers, which are preparations containing live beneficial microbes, can be applied to soils to boost microbial activity and promote plant growth. These products help restore microbial diversity in degraded soils, enhance soil organic matter, and improve resilience against pests and diseases. By promoting a balanced microbial ecosystem, these innovations contribute to sustainable farming practices that support long-term soil health and productivity.

CHAPTER III

MICROBIAL SYMPHONY: HARMONIZING CROP HEALTH AND PRODUCTIVITY

SHARMITHA KRISHNA KUMAR

Assistant Professor, School of Agriculture,

Ponnaiyah Ramajayam Institute of Science and Technology, Tamil Nadu, India

In the intricate world of agriculture, the health and productivity of crops are profoundly influenced by the unseen world of soil microbes. This chapter, “Microbial Symphony: Harmonizing Crop Health and Productivity,” delves into the critical role of soil microorganisms in orchestrating a thriving agricultural ecosystem. These microbes, though invisible to the naked eye, perform vital functions that underpin crop vitality, soil health, and sustainable farming practices.

Soil is a living matrix teeming with a diverse array of microorganisms, including bacteria, fungi, protozoa, and nematodes. This microbial community is integral to the soil’s ecological balance, performing essential tasks such as nutrient cycling, organic matter decomposition, and soil structure formation. Through their interactions with plants and each other, these microbes create a dynamic and supportive environment that enhances crop health and productivity.

One of the key roles of soil microbes is to facilitate nutrient availability. Microorganisms such as mycorrhizal fungi form symbiotic relationships with plant roots, extending their hyphal networks into the soil to access nutrients like phosphorus that are otherwise unavailable to plants. In return, plants provide the fungi with carbohydrates. Similarly, nitrogen-fixing bacteria, such as those in the genus *Rhizobium*, convert atmospheric nitrogen into forms that plants can use, enriching the soil and reducing the need for synthetic fertilizers.

Moreover, soil microbes contribute to disease suppression through biological control mechanisms. Certain beneficial microorganisms can outcompete, inhibit, or directly antagonize plant pathogens, thereby reducing the incidence of soil-borne diseases. This natural disease management reduces the reliance on chemical pesticides and promotes a healthier, more balanced soil ecosystem.

CHAPTER IV
THE MICROBIAL MATRIX: DECODING NATURE'S AGRICULTURAL BLUEPRINT

NIROJADHARMALINGAM,
Assistant Professor, School of Agriculture,
Ponnaiyah Ramajayam Institute of Science and Technology, Tamil Nadu, India

In the ever-evolving landscape of agricultural science, the intricate world of soil microorganisms stands as a cornerstone of understanding and innovation. Chapter IV, titled “The Microbial Matrix: Decoding Nature's Agricultural Blueprint,” delves into the profound role that soil microbes play in shaping the health and productivity of agricultural systems. This chapter provides an in-depth exploration of how the microbial matrix within soil forms a complex yet highly efficient blueprint for sustainable agriculture.

Soil is far more than a simple growing medium; it is a vibrant ecosystem where billions of microorganisms—bacteria, fungi, archaea, and protozoa—interact within a finely tuned network. These microorganisms perform a range of critical functions that are essential for plant growth and soil fertility. By decoding the microbial matrix, we can gain invaluable insights into how these organisms contribute to the nutrient cycles, disease suppression, and overall soil health that underpin agricultural productivity.

Central to this microbial blueprint is the process of nutrient cycling. Soil microbes decompose organic matter, breaking it down into essential nutrients like nitrogen, phosphorus, and potassium that plants need for growth. This natural process not only enriches the soil but also reduces the dependency on synthetic fertilizers, promoting a more sustainable approach to crop production.

Moreover, the chapter highlights the role of beneficial microbial partnerships, such as mycorrhizal fungi, which form symbiotic relationships with plant roots. These fungi extend their hyphal networks into the soil, improving nutrient and water uptake for plants and enhancing their resilience to environmental stresses. Such interactions exemplify the mutual benefits that arise from the microbial matrix and underscore its importance in maintaining crop health and productivity.

CHAPTER V
INNOVATION UNDERGROUND: EXPLORING MICROBIAL MYSTERIES IN
AGRICULTURE

SHARMITHA KRISHNAKUMAR

Assistant Professor, School of Agriculture,

Ponnaiyah Ramajayam Institute of Science and Technology, Tamil Nadu, India

In the hidden depths beneath our feet, an extraordinary world of microorganisms plays a pivotal role in the sustainability and productivity of agriculture. Chapter V, “Innovation Underground: Exploring Microbial Mysteries in Agriculture,” embarks on an enlightening journey into this subterranean realm, uncovering how these unseen players are revolutionizing modern farming practices. This chapter delves into the dynamic interactions within the soil microbiome and their profound implications for agricultural innovation.

Soil is a complex and vibrant ecosystem teeming with a diverse array of microorganisms, each contributing uniquely to soil health and plant growth. This underground community includes bacteria, fungi, archaea, and protozoa, all engaged in processes crucial for nutrient cycling, organic matter decomposition, and disease suppression. Despite their microscopic size, these organisms wield immense influence over soil fertility and crop performance.

Central to the exploration of microbial mysteries is the role of soil microbes in nutrient cycling. Microorganisms break down organic materials, transforming them into essential nutrients such as nitrogen, phosphorus, and potassium that plants need for optimal growth. By understanding and harnessing these microbial processes, we can develop innovative strategies for enhancing soil fertility and reducing reliance on chemical fertilizers, thus fostering more sustainable farming practices.

The chapter also highlights groundbreaking advances in microbial technology, such as the development of microbial inoculants and biofertilizers. These innovations leverage beneficial microorganisms to enhance soil health, improve nutrient availability, and boost plant growth. For example, mycorrhizal fungi and nitrogen-fixing bacteria are being increasingly used to promote plant resilience and productivity in a variety of agricultural settings.

Additionally, the chapter explores how modern agricultural practices can be optimized by decoding microbial interactions.

CHAPTER VI
HARNESSING MICROBIAL DIVERSITY FOR SOIL HEALTH AND CROP
PRODUCTIVITY

MS.D.GOKILAPPRIYA

Assistant Professor, School of Agriculture,

Ponnaiyah Ramajayam Institute of Science and Technology, Tamil Nadu, India

In the intricate web of agricultural ecosystems, microbial diversity stands as a cornerstone of soil health and crop productivity. Chapter VI, “Harnessing Microbial Diversity for Soil Health and Crop Productivity,” delves into the vital role that a rich tapestry of soil microorganisms plays in sustaining and enhancing agricultural systems. This chapter explores how leveraging microbial diversity can lead to more resilient soils and bountiful crops, paving the way for sustainable farming practices.

Soil is a dynamic and living environment, home to a vast array of microorganisms, including bacteria, fungi, archaea, and protozoa. Each group of microorganisms contributes uniquely to soil functions such as nutrient cycling, organic matter decomposition, and disease suppression. The diversity within these microbial communities is essential for maintaining soil health and supporting plant growth.

Microbial diversity enhances soil health by promoting a balanced ecosystem where beneficial microorganisms outcompete or neutralize harmful pathogens. For instance, a diverse microbial community can enhance disease resistance through competitive exclusion and the production of antimicrobial compounds. This natural form of pest and disease management reduces the reliance on synthetic chemicals and fosters a more balanced soil ecosystem.

In addition, diverse microbial communities are crucial for effective nutrient cycling. Different microorganisms are specialized in breaking down various organic materials and converting nutrients into forms that plants can readily absorb. For example, mycorrhizal fungi extend their hyphal networks into the soil, facilitating the uptake of phosphorus and other essential nutrients. Similarly, nitrogen-fixing bacteria convert atmospheric nitrogen into a form usable by plants, enriching the soil and reducing the need for synthetic fertilizers.

CHAPTER VII

INNOVATIVE MICROBIAL STRATEGIES FOR SUSTAINABLE AGRICULTURAL PRACTICES

DR.M.PRIYANGA

Assistant Professor, School of Agriculture,

Ponnaiyah Ramajayam Institute of Science and Technology, Tamil Nadu, India

In the quest for sustainable agriculture, innovative microbial strategies are emerging as pivotal solutions for enhancing soil health, boosting crop productivity, and minimizing environmental impact. Chapter VII, “Innovative Microbial Strategies for Sustainable Agricultural Practices,” delves into cutting-edge approaches that harness the power of microorganisms to create more resilient and eco-friendly farming systems. This chapter explores how leveraging microbial innovations can transform agricultural practices and pave the way for a more sustainable future.

Soil microorganisms, including bacteria, fungi, and other microbes, play fundamental roles in maintaining soil fertility and supporting plant growth. Recent advancements in microbial science have led to the development of novel strategies that utilize these microorganisms to address key challenges in agriculture. These innovative microbial strategies are designed to optimize soil health, enhance nutrient availability, and improve crop resilience while reducing reliance on chemical inputs.

One of the foremost innovations in this field is the use of **microbial inoculants**. These are specially formulated products containing beneficial microbes that are introduced into the soil or directly onto crops. These inoculants can include **nitrogen-fixing bacteria**, which convert atmospheric nitrogen into a form usable by plants, and **mycorrhizal fungi**, which enhance nutrient and water uptake. By boosting the population of these beneficial microbes, farmers can improve soil fertility and crop performance.

Another significant development is the application of **biofertilizers**, which are microbial products that enhance soil health and plant growth. Biofertilizers can improve nutrient availability, stimulate plant growth, and increase resistance to diseases and pests. They offer a sustainable alternative to chemical fertilizers and contribute to the reduction of environmental pollution.

CHAPTER VIII

SOIL MICROBIOME DIVERSITY AND FUNCTION

DR.S.VIGNESHWARAN

Assistant Professor, School of Agriculture,

Ponnaiyah Ramajayam Institute of Science and Technology, Tamil Nadu, India

The soil microbiome, a complex and dynamic community of microorganisms residing within the soil, plays a fundamental role in the health and productivity of agricultural ecosystems. Chapter VIII, “Soil Microbiome Diversity and Function,” provides an in-depth exploration of the diverse microbial inhabitants of the soil and their crucial functions in supporting plant growth, maintaining soil health, and sustaining agricultural productivity.

Soil is far from a static medium; it is a living environment teeming with a vast array of microorganisms, including bacteria, fungi, archaea, and protozoa. Each of these microorganisms contributes uniquely to the soil ecosystem, creating a rich tapestry of life that supports a wide range of ecological processes. The diversity within the soil microbiome is essential for maintaining a balanced and resilient soil environment, capable of sustaining healthy plant growth and robust agricultural systems.

One of the primary functions of the soil microbiome is nutrient cycling. Microbes play a critical role in decomposing organic matter, breaking down complex compounds into simpler forms that plants can readily absorb. For instance, nitrogen-fixing bacteria convert atmospheric nitrogen into ammonia, a form usable by plants, while mycorrhizal fungi extend their hyphal networks to improve phosphorus uptake. These processes are vital for ensuring that plants receive the nutrients they need for optimal growth, thereby enhancing crop productivity.

Soil microorganisms also contribute to soil structure and health. Their activities help form soil aggregates, improving soil aeration, water infiltration, and root penetration. Healthy soil structure supports effective nutrient uptake and reduces erosion and compaction, creating a more favorable environment for plant roots and promoting overall soil fertility.

Furthermore, the soil microbiome plays a key role in disease suppression and pest management.

CHAPTER IX

MYCORRHIZAL FUNGI AND PLANT RELATIONSHIP

DR.K.C.SIVABALAN

Assistant Professor, School of Agriculture,

Ponnaiyah Ramajayam Institute of Science and Technology, Tamil Nadu, India

In the intricate network of soil ecosystems, mycorrhizal fungi stand out as pivotal players in the symbiotic relationships that drive plant health and productivity. Chapter IX, “Mycorrhizal Fungi and Plant Relationships,” delves into the fascinating world of these fungi, exploring how their interactions with plant roots are fundamental to nutrient acquisition, soil structure, and overall plant vitality.

Mycorrhizal fungi form mutualistic partnerships with plant roots, a relationship that has evolved over millions of years. These fungi extend their hyphal networks into the soil, creating an extensive underground web that vastly increases the surface area available for nutrient and water absorption. In return, plants provide the fungi with carbohydrates and other organic compounds essential for their growth. This exchange underscores the symbiotic nature of their relationship, where both partners benefit and thrive.

One of the most significant benefits of mycorrhizal associations is enhanced nutrient uptake. Mycorrhizal fungi are particularly effective at mobilizing and absorbing nutrients that are often less accessible to plant roots, such as phosphorus. By breaking down organic matter and solubilizing mineral forms of phosphorus, these fungi improve the availability of this critical nutrient, which is essential for plant energy transfer, root development, and overall growth. In addition to phosphorus, mycorrhizal fungi can also enhance the uptake of other nutrients, including nitrogen, potassium, and micronutrients.

Beyond nutrient acquisition, mycorrhizal fungi contribute to soil health and structure. The hyphal networks they create help bind soil particles into aggregates, which improves soil porosity, water infiltration, and root penetration. This enhanced soil structure supports robust root systems, reduces erosion, and improves the soil’s ability to retain moisture. Such benefits are crucial for maintaining soil health and resilience, especially in the face of challenging environmental conditions.

CHAPTER X

NITROGEN FIXATION AND RHIZOBIAL SYMBIOSIS

MS.G. PRIYADHARSHINI

Assistant Professor, School of Agriculture,

Ponnaiyah Ramajayam Institute of Science and Technology, Tamil Nadu, India

Nitrogen fixation is a fundamental process in agriculture, crucial for sustaining soil fertility and promoting healthy crop growth. Chapter X, “Nitrogen Fixation and Rhizobial Symbiosis,” explores the intricate relationship between legumes and rhizobial bacteria, a key interaction that underpins natural nutrient cycling and sustainable farming practices. This chapter delves into how this symbiosis enhances soil nitrogen levels, reduces dependency on synthetic fertilizers, and supports agricultural sustainability.

Nitrogen is an essential element for plant growth, playing a critical role in the synthesis of proteins, nucleic acids, and chlorophyll. However, most plants cannot directly utilize atmospheric nitrogen (N_2), which constitutes approximately 78% of the Earth's atmosphere. Instead, they rely on nitrogen compounds in the soil, primarily in the form of ammonia (NH_3) or nitrate (NO_3^-). Nitrogen fixation, the conversion of atmospheric nitrogen into these plant-available forms, is therefore vital for crop production and soil health.

Rhizobial symbiosis represents a remarkable example of biological nitrogen fixation. Rhizobia are a group of soil bacteria that form mutualistic relationships with leguminous plants, such as peas, beans, and clover. Upon infection of the plant roots, rhizobia induce the formation of specialized structures known as nodules. Within these nodules, the bacteria convert atmospheric nitrogen into ammonia through a complex biochemical process involving the enzyme nitrogenase. The ammonia is then assimilated by the plant, while the plant provides the bacteria with carbohydrates and other organic compounds essential for their survival and activity.

This symbiotic relationship offers significant benefits to both partners. For plants, rhizobial nitrogen fixation provides a crucial source of nitrogen, which can enhance growth, yield, and quality.



HARNESSING NATURE'S INTELLIGENCE FOR SUSTAINABLE AGRICULTURE

EDITED BY
DR. NIROJA DHARMALINGAM



978-93-6255-093-4

Harnessing Nature's Intelligence for Sustainable Agriculture
Copyright © 2023 by Dr.NirojaDharmalingam

All rights reserved. No part of this book may be reproduced or transmitted in any form or by any means without written permission from the author.

ISBN: 978-93-6255-093-4

Publisher: Ponnaiyah Ramajayam Institute of Science and Technology(PRIST)

TABLE OF CONTENT

| | |
|---|-----|
| Introduction..... | 6 |
| Chapter I: Microbial Intelligence: Adapting to Agricultural Challenges | 26 |
| Dr.Niroja Dharmalingam, | |
| Chapter II: The Living Soil: Microbial Communities and Carbon Capture | 47 |
| Dr. PriyangaMurugasen, | |
| Chapter III: Agricultural Microbiome Odyssey: Journeying Through Plant-Soil Interactions..... | 68 |
| Ms. GayathriGanesan, | |
| Chapter IV: Invisible Allies: Microbial Strategies for Climate-Resilient Agriculture..... | 90 |
| Ms. Sharmitha Krishna Kumar, | |
| Chapter V: Microbial Medicine for Plants: Strengthening Immunity Naturally | 122 |
| Ms.G.Gayathri | |
| Chapter VI: Ecological Wisdom: Learning form natural systems for sustainable farming.... | 132 |
| Dr.D.Jayakumar | |
| Chapter VII: Biomimicry in agriculture: Applying nature’s Strategies to enhance crop resilience..... | 143 |
| Dr.D.Senthil kumar | |
| Chapter VIII: Agroecology and Biodiversity..... | 153 |
| Dr.K.C.Sivabalan | |
| Chapter IX: Natural Pest Management..... | 166 |
| Dr.S.Vigneshwaran | |
| Chapter X: Soil Health and Regenerative Practices..... | 175 |
| Mr.S.Tamil covane | |

Chapter I

Microbial Intelligence: Adapting to Agricultural Challenges

Dr.Niroja Dharmalingam,

Assistant Professor, School of Agriculture,

Ponnaiyah Ramajayam Institute of Science and Technology, Tamil Nadu, India

As agriculture faces an array of complex challenges, from climate change and soil degradation to pest resistance and dwindling resources, the concept of "microbial intelligence" emerges as a beacon of hope. Microbial intelligence refers to the remarkable adaptability and resourcefulness of microorganisms in responding to and mitigating agricultural stresses. By harnessing the inherent problem-solving abilities of microbes, we can develop innovative strategies to address these pressing agricultural issues and pave the way for more resilient and sustainable farming systems.

Microbes, including bacteria, fungi, and other microorganisms, possess extraordinary capabilities to adapt to varying environmental conditions. Their ability to thrive in diverse and often harsh environments is rooted in their evolutionary resilience and metabolic diversity. This adaptability makes them invaluable in addressing agricultural challenges. For instance, certain microbes can enhance soil fertility and health even under suboptimal conditions, such as nutrient-poor or acidic soils. By forming symbiotic relationships with plants, these microbes can improve nutrient uptake, bolster plant defenses, and promote growth, effectively helping crops to better withstand adverse conditions.

One area where microbial intelligence proves particularly transformative is in the management of soil health and fertility. Microbes play a crucial role in nutrient cycling, organic matter decomposition, and soil structure formation. Their ability to break down complex organic materials and recycle nutrients enhances soil fertility and supports plant growth. Additionally, microbes can help remediate contaminated soils by breaking down pollutants, thus restoring soil health and making it suitable for agriculture once again.

In pest and disease management, microbial intelligence also shines. Beneficial microbes can suppress soil-borne pathogens and pests through various mechanisms, including competition, antagonism, and the production of antimicrobial compounds. For example, certain bacteria

Chapter II

The Living Soil: Microbial Communities and Carbon Capture

Dr. Priyanga Murugasen

Assistant Professor, School of Agriculture

Ponnaiyah Ramajayam Institute of Science and Technology, Tamil Nadu, India

In the ongoing battle against climate change, the potential of soil to act as a carbon sink is increasingly recognized as a critical strategy for mitigating greenhouse gas emissions. At the heart of this process lies the often-overlooked but profoundly influential role of soil microbial communities. These microscopic organisms are not merely inhabitants of the soil; they are active participants in the intricate processes of carbon capture and storage. Understanding their roles in this vital ecological function offers promising avenues for enhancing soil health and combating climate change.

Soil, often regarded as a passive medium for plant growth, is actually a dynamic and complex ecosystem teeming with microbial life. Bacteria, fungi, protozoa, and other microorganisms interact within the soil matrix, driving key processes that influence carbon dynamics. These microbial communities are essential for the decomposition of organic matter, a fundamental step in the carbon cycle. As microbes break down plant residues and other organic materials, they convert complex carbon compounds into simpler forms. Some of this carbon is released as carbon dioxide (CO₂) into the atmosphere, while the rest is stabilized in the soil as organic matter, contributing to long-term carbon sequestration.

The process of carbon capture in soil is influenced by various factors, including microbial activity and soil management practices. Microbial communities play a pivotal role in the formation of stable soil organic matter, which includes humus and other carbon-rich compounds. This stable carbon is less prone to decomposition and can remain in the soil for years to centuries, acting as a long-term carbon sink. By enhancing microbial activity and promoting the formation of soil aggregates, which protect organic matter from rapid decomposition, we can increase the soil's capacity to store carbon.

Soil management practices, such as conservation tillage, cover cropping, and organic amendments, have significant impacts on microbial communities and their ability to capture carbon.

Chapter III

Agricultural Microbiome Odyssey: Journeying Through Plant-Soil Interactions

Ms. GayathriGanesan,

Assistant Professor, School of Agriculture

Ponnaiyah Ramajayam Institute of Science and Technology, Tamil Nadu, India

The intricate dance between plants and soil microorganisms is a captivating and critical aspect of agriculture, embodying a complex symbiosis that drives ecosystem functionality and crop productivity. As we embark on an "Agricultural Microbiome Odyssey," we explore this hidden world of interactions, unveiling how microbial communities shape plant health, soil fertility, and overall agricultural sustainability. This journey delves into the symbiotic relationships that form the foundation of productive and resilient agricultural systems.

The term "microbiome" refers to the collective assemblage of microorganisms residing in a specific environment, such as the soil or plant roots. In agricultural systems, the plant-soil microbiome is a dynamic and interactive community comprising bacteria, fungi, archaea, and other microorganisms. These microbes engage in a myriad of interactions with each other and with plant roots, influencing numerous aspects of soil health and plant growth.

One of the primary functions of the plant-soil microbiome is nutrient acquisition. Plants rely on soil microbes to access essential nutrients that are otherwise inaccessible. Mycorrhizal fungi, for instance, form symbiotic relationships with plant roots, extending their hyphal networks into the soil. This interaction enhances nutrient uptake, particularly phosphorus, which is crucial for plant growth. Similarly, nitrogen-fixing bacteria such as *Rhizobium* and *Azotobacter* convert atmospheric nitrogen into forms that plants can utilize, reducing the need for synthetic fertilizers and promoting soil fertility.

Beyond nutrient acquisition, the plant-soil microbiome plays a crucial role in enhancing plant resilience and health. Beneficial microbes can stimulate plant immune responses, making plants more resistant to pests and diseases. For example, certain bacteria and fungi produce compounds that suppress pathogenic organisms or induce systemic resistance in plants. This natural form of pest and disease management reduces reliance on chemical pesticides and supports more sustainable farming practices.

Chapter IV

Invisible Allies: Microbial Strategies for Climate-Resilient Agriculture

Ms. Sharmitha Krishna Kumar

Assistant Professor, School of Agriculture

Ponnaiyah Ramajayam Institute of Science and Technology, Tamil Nadu, India

In the face of accelerating climate change, agriculture is at a crossroads, grappling with challenges that threaten food security and environmental sustainability. Amidst these challenges, a silent yet powerful ally is emerging: the microbial world. "Invisible Allies" delves into how microorganisms, though often unseen, are playing a crucial role in developing climate-resilient agricultural systems. By understanding and harnessing these microbial strategies, we can fortify our agricultural practices against the uncertainties of a changing climate.

Microbes, including bacteria, fungi, and other microorganisms, are fundamental to many processes that underpin soil health and plant growth. Their roles extend far beyond mere presence in the soil; they are actively involved in processes that enhance the resilience of agricultural systems to climate-related stresses. For instance, microbial communities contribute to soil structure and fertility, improve water retention, and assist in the decomposition of organic matter, all of which are essential for sustaining crop productivity under varying climatic conditions.

One of the critical ways microbes support climate resilience is through enhancing soil moisture management. Drought, a frequent consequence of climate variability, can severely impact crop yields. However, certain soil microorganisms help mitigate these effects by improving soil structure and increasing its water-holding capacity. Mycorrhizal fungi, for example, form symbiotic relationships with plant roots, extending their networks into the soil and aiding in water and nutrient uptake. These fungi enhance the plant's ability to withstand periods of water scarcity, making crops more resilient to drought.

Microbes also play a role in soil carbon sequestration, a crucial process for mitigating climate change. Soil organic matter, which contains stored carbon, is stabilized by microbial activity. Microbes decompose organic materials, converting them into stable forms of carbon that remain in the soil for extended periods.

Chapter V

Microbial Medicine for Plants: Strengthening Immunity Naturally

Ms.G.Gayathri

Assistant Professor, School of Agriculture

Ponnaiyah Ramajayam Institute of Science and Technology, Tamil Nadu, India

In the quest to enhance crop health and productivity, the concept of "microbial medicine" emerges as a transformative approach, offering natural solutions to strengthen plant immunity. As agriculture increasingly seeks sustainable and eco-friendly alternatives to synthetic chemicals, harnessing the power of beneficial microorganisms represents a groundbreaking advancement in plant health management. This chapter, "Microbial Medicine for Plants," explores how microbes function as nature's own healthcare providers, fortifying plant defenses and promoting resilience through natural mechanisms.

Plants, much like humans, are susceptible to a range of diseases and pests that can impact their growth and productivity. Traditionally, managing these threats has relied heavily on chemical pesticides and fertilizers. However, these approaches often come with environmental and health concerns, prompting a shift toward more sustainable practices. Microbial medicine offers a promising alternative by utilizing naturally occurring microorganisms to boost plant immunity and suppress pathogens.

Beneficial microbes such as plant growth-promoting rhizobacteria (PGPR), mycorrhizal fungi, and endophytic bacteria play a crucial role in plant health. These microorganisms interact with plants in ways that enhance their natural defenses. For example, PGPRs colonize plant roots and produce antimicrobial compounds that inhibit the growth of harmful pathogens. They also stimulate systemic resistance, a state in which plants develop heightened immunity throughout their tissues, preparing them to fend off future infections more effectively.

Mycorrhizal fungi form symbiotic relationships with plant roots, extending their hyphal networks into the soil. This association not only improves nutrient and water uptake but also enhances the plant's resistance to soil-borne diseases. The fungi can produce compounds that directly inhibit pathogen growth or alter the soil environment in ways that make it less hospitable to harmful microbes.

CHAPTER VI

ECOLOGICAL WISDOM: LEARNING FROM NATURAL SYSTEMS FOR SUSTAINABLE FARMING

DR.D.JAYAKUMAR

Professor, School of Agriculture

Ponnaiyah Ramajayam Institute of Science and Technology, Tamil Nadu, India

In the face of pressing environmental challenges and the need for resilient agricultural practices, the concept of "Ecological Wisdom" offers a compelling paradigm for sustainable farming. This approach draws inspiration from natural systems, embracing the intricate balance and resourcefulness inherent in ecosystems to inform and enhance agricultural practices. By learning from nature's time-tested strategies, we can develop farming methods that are not only productive but also ecologically harmonious and resilient.

Natural ecosystems operate through complex interactions and feedback loops that ensure stability and sustainability. In these systems, biodiversity, nutrient cycling, and energy flows are carefully balanced, leading to healthy and self-sustaining environments. Agricultural systems, however, often deviate from these natural principles, leading to challenges such as soil degradation, loss of biodiversity, and over-reliance on synthetic inputs. Ecological Wisdom advocates for a shift towards farming practices that align more closely with the principles observed in natural ecosystems.

One key aspect of ecological wisdom is the integration of biodiversity into agricultural systems. In natural ecosystems, a diverse array of species contributes to ecosystem stability and resilience. Similarly, incorporating diversity into agricultural landscapes—through practices such as crop rotation, polycultures, and agroforestry—can enhance soil health, reduce pest and disease pressure, and increase overall farm resilience. Diverse plantings attract beneficial insects, improve soil structure, and foster a more balanced microbial community, all of which contribute to a more sustainable and productive farming system.

Nutrient cycling, another cornerstone of ecological wisdom, emphasizes the efficient use of resources and the reduction of waste. In natural systems, nutrients are continually recycled through decomposition and the interactions between plants, animals, and microorganisms.

CHAPTER VII
**BIOMIMICRY IN AGRICULTURE: APPLYING NATURE’S STRATEGIES TO
ENHANCE CROP RESILIENCE**

DR.D.SENTHIL KUMAR

Assistant Professor, School of Agriculture

Ponnaiyah Ramajayam Institute of Science and Technology, Tamil Nadu, India

In the quest for more sustainable and resilient agricultural systems, biomimicry emerges as a revolutionary approach, drawing inspiration from nature's time-tested strategies to solve modern agricultural challenges. "Biomimicry in Agriculture: Applying Nature’s Strategies to Enhance Crop Resilience" explores how mimicking the ingenious adaptations and processes found in natural ecosystems can lead to innovative solutions for enhancing crop resilience and sustainability.

Biomimicry, the practice of emulating nature’s designs and processes, has already proven transformative in fields ranging from engineering to medicine. In agriculture, this approach offers a promising pathway to address issues such as climate change, soil degradation, and pest management. Nature, through millions of years of evolution, has developed sophisticated mechanisms for managing resources, coping with environmental stresses, and optimizing growth. By observing and applying these natural strategies, we can create agricultural systems that are more robust, efficient, and aligned with ecological principles.

One key area where biomimicry is making an impact is in enhancing crop resilience to environmental stresses. For instance, desert plants such as cacti and succulents have evolved remarkable water-conservation strategies to survive in arid conditions. By studying these plants, researchers have developed irrigation techniques and soil amendments that improve water retention and drought resistance in crops. Similarly, the structural properties of lotus leaves, which repel water and resist dirt accumulation, have inspired the development of self-cleaning and water-resistant coatings for agricultural equipment and structures.

Soil health is another critical aspect where biomimicry offers valuable insights. Natural ecosystems rely on a diverse community of organisms to maintain soil fertility and structure. Mimicking this approach, practices such as creating biochar from plant residues and implementing no-till farming can enhance soil organic matter and microbial activity.

CHAPTER VIII

AGROECOLOGY AND BIODIVERSITY

DR.K.C.SIVABALAN

Assistant Professor, School of Agriculture

Ponnaiyah Ramajayam Institute of Science and Technology, Tamil Nadu, India

In an era marked by pressing environmental challenges and the need for sustainable agricultural practices, agroecology stands out as a transformative approach that integrates ecological principles into farming systems. At its core, agroecology is not just a set of practices but a holistic framework that draws on ecological knowledge to create agricultural systems that are resilient, productive, and harmonious with nature. Central to this framework is the role of biodiversity—both in terms of the variety of crops and the diversity of organisms within agricultural landscapes.

Biodiversity in agroecology encompasses the variety of plants, animals, microorganisms, and the genetic diversity within these groups that contribute to the health and functionality of agricultural ecosystems. This diversity is essential for maintaining soil fertility, managing pests and diseases, and enhancing the overall resilience of farming systems. By fostering a rich tapestry of life, agroecology aims to emulate natural ecosystems, where interactions between species support the stability and productivity of the environment.

Agroecological principles encourage farmers to view their fields as dynamic, living systems rather than static plots of land. This perspective shifts the focus from monoculture, which can deplete soil nutrients and increase vulnerability to pests, to polyculture and agroforestry, which leverage the complementary relationships among different species. For instance, the practice of intercropping—growing different crops in proximity—can reduce pest outbreaks, enhance soil health, and increase yields by mimicking natural plant communities.

Furthermore, the integration of biodiversity into agricultural systems also involves the management of natural habitats such as hedgerows, wetlands, and wildflower strips within and around farm areas. These elements not only support wildlife but also provide crucial ecosystem services, including pollination and pest control, which in turn benefit production. The preservation of local plant varieties and animal breeds also plays a vital role,

CHAPTER IX

NATURAL PEST MANAGEMENT

DR.S.VIGNESHWARAN

Assistant Professor, School of Agriculture

Ponnaiyah Ramajayam Institute of Science and Technology, Tamil Nadu, India

As the global agricultural landscape grapples with the challenges of sustainability and environmental impact, natural pest management emerges as a compelling alternative to conventional pest control methods. This chapter explores the principles and practices of natural pest management, which harnesses ecological processes and natural enemies to control pest populations while minimizing reliance on synthetic chemicals.

Natural pest management is grounded in the understanding that pest control is most effective when it aligns with the dynamics of natural ecosystems. Unlike conventional methods that often involve broad-spectrum pesticides, natural pest management emphasizes the use of ecological interactions and biological controls to maintain pest populations at manageable levels. This approach not only protects crops but also fosters a healthier environment by promoting biodiversity and reducing chemical inputs.

At the heart of natural pest management is the use of beneficial organisms—such as predatory insects, parasitoids, and pathogens—that naturally regulate pest populations. For example, ladybugs, lacewings, and predatory beetles can be introduced or encouraged in agricultural settings to target aphids, mites, and other harmful insects. Similarly, parasitoid wasps lay their eggs on or inside pests, ultimately controlling their numbers in a targeted manner. By supporting and enhancing these natural enemies, farmers can reduce pest pressures without disrupting the ecological balance.

Additionally, natural pest management incorporates strategies such as habitat manipulation, crop rotation, and intercropping to create environments that are less conducive to pest outbreaks. By diversifying plant species and structuring landscapes to include beneficial habitats, farmers can reduce the incidence of pest infestations and promote a more resilient agroecosystem.

CHAPTER X

SOIL HEALTH AND REGENERATIVE PRACTICES

MR.S.TAMIL COVANE

Assistant Professor, School of Agriculture

Ponnaiyah Ramajayam Institute of Science and Technology, Tamil Nadu, India

Soil health is the cornerstone of sustainable agriculture, underpinning the productivity and resilience of farming systems. As the foundation of our food production, soil quality directly influences crop yields, ecosystem services, and environmental sustainability. This chapter delves into the vital role of soil health and explores regenerative practices that restore and enhance soil function, paving the way for more resilient and productive agricultural systems.

Soil health is more than just a measure of nutrient levels; it encompasses the biological, physical, and chemical properties that collectively support plant growth and ecosystem vitality. Healthy soils are teeming with microbial life, have a well-structured physical matrix, and possess a balanced chemical composition. These attributes contribute to effective nutrient cycling, water infiltration, and disease suppression, all of which are crucial for sustainable crop production.

Regenerative practices are designed to improve soil health by mimicking natural processes and focusing on long-term ecological balance. One foundational practice is **cover cropping**, which involves planting crops specifically to cover the soil, rather than for harvest. Cover crops, such as legumes, grasses, and brassicas, contribute to soil health by preventing erosion, enhancing soil structure, increasing organic matter, and fixing atmospheric nitrogen. This practice not only enriches the soil but also supports biodiversity and improves water retention.

Reduced tillage is another key regenerative practice that helps maintain soil integrity. Traditional tillage can disrupt soil structure, reduce organic matter, and harm beneficial organisms. By minimizing soil disturbance, reduced tillage preserves soil aggregation and encourages the growth of a healthy microbial community. This approach supports better water infiltration and reduces soil erosion, contributing to overall soil health and sustainability.



COLLECTION OF POEMS

EDITED BY

Dr. G.KARTHIKEYAN



978-93-6255-813-2

Collection of poems

Copyright © 2023

by Dr.G.KARTHIKEYAN

All rights reserved. No part of this book may be reproduced or transmitted in any form or by any means without written permission from the author.

ISBN: 978-93-6255-013-2

Publisher: Ponnaiyah Ramajayam Institute of Science and Technology

(PRIST)

| CONTENT | PAGE |
|--|--------------|
| CHAPTER-10.1 Childhood Memories In Toru Dutt’s “Our Casuarina Tree” Dr. K. Shibila | 1-7 |
| CHAPTER -10.2 God's Omnipotence in Hopkins' 'God's Grandeur' Dr.R.A.Rajasekaran | 8-12 |
| CHAPTER-10.3 Gothic Romanticism In Edgar Allen Poe’s The Tell-Tale Heart Dr.D.RAVIKUMAR | 13-18 |
| CHAPTER –10.4 Study in Thematic Repetition and Development in GerontionByT.S.Eliot Dr.N.PREMA | 19-27 |
| CHAPTER-10.5 Style and Diction in Our Casuarina Tree. Dr.E.GEETHA | 28-37 |
| CHAPTER-10.6 Transfer of A Child’s Affections From Parent To Lover From Ruzia Kahn’s My Daughters Boyfriend R.VISALAKSHI | 38-41 |
| CHAPTER-10.7 Transformation in W.B. Yeats’ “Sailing To Byzantium” Ms.K.JAYAPRIYA | 42-46 |
| CHAPTER-10.8 Ineffable Mystic Experience of Nature Found Embedded in The Select Poems of Mary Oliver Mr.M.AMALRAJ | 47-58 |
| CHAPTER-10.9 Longing To Be Free and Aftermath in Sylvia Plath's Daddy. Mr.S.RASAKUMAR | 59-64 |

CHAPTER-10.1

CHILDHOOD MEMORIES IN TORU DUTT'S "OUR CASUARINA TREE"

Dr. K. Shibila

Professor, Department Of English, Prist Deemed To Be University, Thanjavur.

Abstract:

Poetry represents human thoughts. The internal conflicts that a poet develops right from his/her childhood leaves a grave impression on their mind as they grew up. Sometimes society too plays a great role in the life of a poet. Every poet gathers inspiration from some source both internally or externally. Toru Dutt is such a leading Indian woman poet in English who translated many French poems into English. The love for learning she developed right from her childhood and this specialty made her to learn three languages. One can observe the influence of sacred Hindu texts like *Ramayana*, *Mahabharata*, and *Puranas* on her poetry. Her poem "Our Casuarina Tree" celebrates her reminiscence of a happy childhood she spent in India with her beloved siblings. The Casuarina Tree in the poem is used as a symbolic representation of the poet's memories of the past.

Keywords: Poetic Imagination, Hindu philosophy, Symbolism, Epics, and Myths

Introduction

The Indian Poetry in English started with verse romances, melody, and lyrics; or it may be appropriate to say that it began with romanticism. It is Prof. V. K. Gokak who divided the Indo- Anglican poetry roughly into six phases: 1825-1850 – the First Phase, 1851-1875 – the Second Phase, 1876-1900 – the Third Phase, 1901-1925 – the Fourth Phase, 1926-1950 – the Fifth Phase, and 1951-1965 – the Sixth Phase. According to the critics of Indian Poetry in English, the poetry which sprouted during the time period of 1876 to 1925 can be phrased as Indo-Anglian Romanticism. It is believed that in India, the poetry first instigated in Bengal, the province which was under the dominion of British for many years. The pioneers of Indo-Anglian literature were men of letters and the majority of upper class who made their meticulous attempts to explain the significance of ethical and cultural values of India to the West through a new form of genre known as 'imaginative literature.' They took the help of five different forms of imaginative literature i.e., Fantasy, Fairytale, Myth, Legend, and Fable in order to give precision to their works. Consequently, one can understand the growth and development of Indian poetry on the pasture of Indo-Anglian literature is a result of many trials, struggles for convention, independence, improvement and replication. Right from the beginning, almost all the poets of Indian origin who are writing in English were found to be holding two torrents, foreign influences and Indian elements in poetry.

The poets who appeared before Henry Louis Vivian Derozio made Christian sentiments and traditions, Nature, and Indian legends as their subject matter and framed their works.

Chapter 10.2

God's Omnipotence in Hopkins' 'God's Grandeur

Dr.R.A.Rajasekaran

Professor, Department Of English, Prist Deemed To Be University, Thanjavur.

Abstract:

This analysis delves into the concept of God's omnipotence in Gerard Manley Hopkins' poem "God's Grandeur." Through a close reading of the poem's imagery, symbolism, and theological undertones, this study reveals how Hopkins' depiction of divine power intersects with Catholic theology and philosophical notions of omnipotence. The poem's exploration of God's immanence and transcendence is examined, highlighting the tension between human neglect and divine providence. By unpacking Hopkins' poetic representation of God's grandeur, this research demonstrates the enduring relevance of omnipotence as a theological and philosophical concept.

Keywords: Omnipotence, Catholic Theology, Immanence, Transcendence, Divine Providence.

Introduction

Ever since the creation of this world there have been souls to praise God, in His reflected beauty in nature. The god grandeur vividly gives the beauties of Cod's creation - the glories of stars, the brightness of the rainbow, the dazzling splendor of sun, the heart-captivating smile of moon, the majesty of mountains, the breathtaking beauty of the flying clouds, the melodious music of the birds, the might of thunder and lightening, etc. In spite of all these manifestations of the Almighty. God's primary purpose of creation was to communicate, to manifest and to share some of His infinite truths, goodness and beauty with the creation.⁶ Hence one cannot fail to glimpse the shadow of God in every inanimate and animate being of this world.

In late August 1874, Gerard Hopkins arrived at St Bueno's, the seminary where he was to study "dogmatic theology, moral ditto, canon law, church history, scripture, Hebrew and what not"¹; in preparation for his ordination, which took place three years later on Sunday 23 rd September 1877. Prior to joining the Jesuit Order, Hopkins had burnt all the verse he had till then written, and had resolved "to write no more, [...], unless it were by the wish if my superiors"². His resolve changed after reading newspaper reports of the tragedy of the foundered German ship, "Deutschland", in the mouth of the Thames in December 1875. He immediately composed what was to be his longest and possibly most ambitious poem "Wreck of the Deutschland", which was rejected for publication in 1876.³ Nonetheless, once struck, the creative spark refused to be extinguished and Hopkins needed little further inducement to continue writing poetry. Indeed, St Bueno's was the place where he was to write some of his most memorable and best verse and around a third of his written work stems from this period, with the majority written in the last year.

CHAPTER-10.3

Gothic Romanticism In Edgar Allen Poe's The Tell-Tale Heart

Dr.D.RAVIKUMAR

Professor, Department Of English, PRIST Deemed to be University, Thanjavur.

Abstract:

Edgar Allen Poe is a very prominent example of a gothic and romantic author. He is classified as a romantic author because he focuses on the emotional side of his stories, not the intellectual side. Romantic authors feel that facts have no place in art and simply want you to feel how the character feels. Poe's work can also be called gothic. Gothic literature often includes a very sensitive hero who would not be able to fit into the outside world. Another characteristic of gothic work is that the characters typically have psychic abilities. Typical gothic art will also include something pertaining to life after death. A perfect example of a Poe character who displays both gothic and romantic characteristics is the narrator of "The Tell-Tale Heart".

Keywords: Emotional, sensitive, psychic abilities

Introduction

Edgar Allan Poe is a very dark writer. He has written many well known stories or poems like The Raven, The Tell-Tale Heart, and The Fall of the House of Usher. Even though Poe is well known, many people do not know Poe's past. Poe's past was very dark, like his texts. He did not have a very good life. Poe's parents were actors who traveled around. Poe's parents both died when he was very young, so Poe was taken away from all of his siblings to live with a new family. His new father John Allan tried to make Poe become successful in business, just like him. That did not work out because Poe really just wanted to become a writer. As a little kid, Poe wrote a lot of good poems, but Allan did not want to support his writing. Poe wanted to go into writing in college so Allan begrudgingly sent him away to college, but did not really help him out with the costs. Poe got engaged to Elmira Royster, but while he was away at college, she got engaged to someone else. Poe became very upset about Allan not giving him enough money and Elmira, so he left the house and decided to become a successful poet.

While he was gone he published his first book. His mother became very ill with tuberculosis while he was gone. When Poe came home to see his dying mother, it was too late. She had died. Poe then wrote another book. Then Allan helped Poe go to the United States Military Academy at West Point. Poe was kicked out of that school, but before he got kicked out he was able to write another book. Poe went back to his original house, but he was very poor and got robbed, so Poe had to move in with his aunt.

CHAPTER -10.4

Study in Thematic Repetition and Development in Gerontion By T.S. Eliot

Dr. N. PREMA

Associate Professor, Department Of English, Prist Deemed To Be University, Thanjavur.

Abstract:

The speaker of the poem is an old man in an old house whose thoughts drift while being read to by a boy, and these thoughts form the poem. He misses fighting in the war and laments his presence in the mundane and common-place house. He speaks of the depravity of humanity in the then world. Lured by modernism, they covered the truth with darkness, taking only some of it with them and interpreting it as they wish. He describes the countries' actions in World War I. He says that all sinners have divine judgment coming for them. And he was going to receive it too, for he was removed from near the heart of Him. He was removed not because of his sins but because of his loss of passion. He discarded passion of his own will rather than seeing it get corrupted. He speaks of the humans running around mechanically, their brains working while their hearts have cooled down. And he has no part in these workings, in these changes of modernism, and so he has been driven into a sleepy corner, untouched by the world. The speaker, the old man, the Gerontion, gives his opinions and impressions of the modern world and laments the direction which it was taking.

Keywords: laments, modernism, judgment, direction

Introduction

Thomas Stearns Eliot, who is believed to be one of the most important poets of his time in the English and American Poetry, as well as today, left many poems in most of which he criticized and even rejected the Western Puritanist society and the principles of Romanticism. In this brief study, one of T.S. Eliot's major poems, 'Gerontion' will be presented with other critics' and this researcher's interpretations. The speaker of the poem is an old man in an old house whose thoughts drift while being read to by a boy, and these thoughts form the poem. He misses fighting in the war and laments his presence in the mundane and common-place house (Basu, 2017). Since it will be useful to know T.S. Eliot's philosophy of life and his background in order to understand and interpret his works better, his life story and background are also provided briefly in the first part of this study. In the final part, conclusions in connection with the society in which we live in were drawn from T.S. Eliot's 'Gerontion'.

Davies, Gardner and Tate (2018) give a brief summary of Eliot's early years and state Eliot was a member of a recognized New Britain family that had moved to St. Louis, Missouri.

CHAPTER-10.5

Style and Diction in Our Casuarina Tree.

Dr.E.GEETHA

Assistance Professor, Department Of English, Prist Deemed To Be University, Thanjavur.

Abstract:

A language can touch many aspects of human life. As a part of our environment, nature is one of the most important aspects associated with the life cycle of humans, ranging from birth, basic survival, societal and mental needs to overall development. Combining language with nature, Eco linguistics has emerged as a specialized branch which attends to the issues related to the environment. The earlier studies, in general, have shown the challenging aspects of our environment and the role of language in dealing with the same. However, an important aspect which is the positivity of a language for the environment and vice versa, has received less importance. The present study offers a stylistic evaluation under the lights of the Eco linguistics of a famous poetic work in English by an Indian poet, Toru Dutt. This study analyses Our Casuarina Tree to explore its relevance to nature. The linguistic and literary elements analyzed are imagery, symbolism, syntax and rhythm. The study reviews writing styles and their impact on the reader's experience by examining how her stylistic devices improve the poem's aesthetic and semantic qualities and simultaneously show a deep relationship among nature, language and human emotions. The study clarifies the importance of eco linguistic parameters in comprehending, appreciating, and relating nature with human emotions through language.

Keywords: Casuarina Tree, Eco linguistics, Language, Nature and Emotions, Stylistics

INTRODUCTION

Eco linguistics is a subfield of language that studies how language and discourse affect the environment and ecology. Some of the sustainable development goals (2019, United Nations), like Climate Change (G13) and Biodiversity (G14; G15), show concerns over issues related to our environment. Eco linguistics, a subfield of language, can contribute to and address critical ecological issues. Moreover, there is also a need to develop theories that must see humans as a part of society and the largerecosystems that life depends on (Stanlaw James, 2020; The International Eco linguistics Association).

CHAPTER-10.6

Transfer of A Child's Affections From Parent To Lover From Ruzia Kahn's My Daughters Boyfriend

R.VISALAKSHI

Assistance Professor, Department Of English, Prist Deemed To Be University, Thanjavur.

Abstract:

In "My Daughter's Boyfriend," Ruzia Khan provides a heartfelt exploration of the painful intersection between parental protection and a child's emotional independence. The poem resonates with readers who have experienced either side of this dynamic—whether as a parent worrying over a child or as someone who has clung to hope in an unhealthy relationship. Its simple, direct language belies the complexity of emotions and relationships it addresses, making it a poignant reflection on love, heartbreak, and the challenges of letting go.

Keywords: emotional, worrying, relationship, complexity

Introduction

In the poem, "My Daughter's Boy Friend." The poetess describes the agony of a mother when she sees her daughter's love is shifting from her to her boy friend. The poem projects the life of the mother before and after the arrival of her daughter's boy friend and how it has changed her life. The poem "My Daughter's Boyfriend" talks about the transfer of a child's affections from parent to lover and the emotions experienced by the parent on observing this. The speaker rethinks all the love and care that she had showered on her daughter and her heart breaks when she watches a stranger could easily take away her own daughter from her hands.

Boy friend's arrival

The mother experiences strange happenings when she hears importunate knocks at the door. The pleading knocks on the door create a strange feeling in her mind that something bad will happen. The boy friend enters the house and un-noticing the mother's presence he goes straight like a blind man to his lady love. He ignores the presence of the mother and has no consideration for the pains that the mother took to bring up his lady love. He with his lady love drifts away into world of their own, where there is no place for the doting moth.

Mother's world

The mother's world revolves around the daughter. She is happy and at peace in the presence of her daughter. But she feels a threat to her happiness upon the arrival of her daughter's boyfriend. She was filled with pride when the child was in her womb. She gave birth to her daughter after undergoing labor pain. When her daughter fell sick, she spent sleepless nights. She showered love and affection on her daughter and took much pain and care to bring her up well.

CHAPTER-10.7

Transformation in W.B. Yeats' "Sailing To Byzantium"

Ms.K.JAYAPRIYA

Assistance Professor, Department Of English, Prist Deemed To Be University, Thanjavur.

Abstract:

"Sailing to Byzantium" takes readers on a metaphorical voyage, intertwining the physical and spiritual realms to illuminate the human desire for immortality and an eternal existence. Through rich imagery, symbolism, and a masterful use of poetic techniques, Yeats crafts a captivating narrative that resonates deeply with readers. This paper aims to delve into the theme of transcendence within the poem, uncovering the various literary devices and imagery employed by Yeats to convey the speaker's quest for a higher state of being., symbolism, and the use of literary devices. We will examine the speaker's yearning for a spiritual transformation, his fascination with the eternal world symbolized by Byzantium, and the juxtaposition of aging mortality against timeless art. Additionally, it delves into the historical and cultural context of the poem, considering Yeats' influences from Irish mythology, the occult, and his fascination with Byzantine art.

Keywords: Spiritual, immortality, transcendence, fascination

Introduction

William Butler Yeats, a renowned Irish poet and one of the most influential figures in 20th-century literature, captivated readers with his evocative and profound works. Among his vast collection of poems, "Sailing to Byzantium" stands as a notable testament to Yeats' exploration of themes such as aging, mortality, and the longing for spiritual transcendence. Published in 1928 as part of his collection "The Tower," this poem delves into the speaker's yearning for a transformative journey, seeking a realm beyond the limitations of human existence. W.B. Yeats wrote "Sailing to Byzantium" in the early 1920s, a time of great social, political, and cultural upheaval in Ireland and Europe. Yeats was a leading figure in the Irish Literary Revival, a movement that sought to revive and promote Irish literature and culture, which had been suppressed during centuries of British rule.

Yeats himself was deeply influenced by theosophy and occultism, which he saw as a means of unlocking spiritual truths and elevating human consciousness. The poem's reference to Byzantium, the capital of the Eastern Roman Empire, reflects Yeats' fascination with the city's rich cultural and artistic heritage. Byzantium was renowned for its mosaics, architecture, and religious art, which symbolized the enduring power and beauty of human creativity. Yeats saw Byzantium as a place of transcendent beauty and spiritual richness, an idealized realm that offered an escape from the decay and transience of mortal life.

CHAPTER-10.8

Ineffable Mystic Experience of Nature Found Embedded in The Select Poems of Mary Oliver

Mr.M.AMALRAJ

Assistance Professor, Department Of English, Prist Deemed To Be University, Thanjavur.

Abstract

Considering the significance of eco poetry and how it widens the ecological horizons of the readers, tracing the eco poet's mental transition from the moment of direct sensual experiences in Nature to the act of composition enables the readers to fathom out what lies behind the poetic imagination, bringing about the ecological sense of union with the natural. As for the purpose of this study, the researchers intend to examine the eco centric-eco poetic elements of the selected eco poems out of Mary Oliver's New & Selected Poems, Vol. 1 with the aim of bringing to light the fact that Oliver's main attempt is inviting her readers to reach mental growth through her bringing forth the consciousness that derives from the power of imagination and acute attention given to the world of the non-human, enabling the speaker-poet and her readers to do away with the barriers of self-centeredness and take part in a collective reunion with Nature. Accordingly, the general framework that has been used to conduct the following research is Ecocriticism and its celebration of ecological wholeness between human and non-human agents.

Keywords: poetic imagination, Mary Oliver, nature, ecopoetry, ecological wholeness.

Introduction

Human beings' faculty of imagination is the main gate through which one can contemplate the most unthinkable and the farthest places. Agreeing that human mind is the medium that conditions all the situations, it can be deduced that we are transformed by its impact both within us upon us (Abram, 2010). Be that for real or not, it is the wing of imagination that carries human mind over all the universe and makes it travel with the natural. Probably Mary Oliver had the same point in mind when she wrote, "Said the river: imagine everything you can imagine, then / keep on going" (2009, p. 51). In order for the human beings to be able to imagine Nature and natural elements, they need to go beyond their selves, egos, and join the melodious tune of Nature. As such, they reach a unified insight that leads to a concordant bond between man and Nature in the end (Matthew, 2008). Yet, reaching such holistic vision requires the eco poet to grant the readers the insight to fathom out the fact that we should counter "the singular totalitarian idea of control" and make room for "the old ideals of harmony, symmetry, balance, order" (W. Berry, 1983, p. 4). A good starting point, as Iovino has remarked, is to "restore ecological imagination as our fundamental 'survival unity,'" for it can reunite man with the land (Lynch et al., 2012, p. 107).

CHAPTER-10.9

Longing To Be Free and Aftermath in Sylvia Plath's Daddy.

Mr.S.RASAKUMAR

Assistance Professor, Department Of English, Prist Deemed To Be University, Thanjavur.

Abstract:

Sylvia plath's poems are characterized by cruel honesty and gloomy atmosphere. In this poem, the poet frequently illustrates the themes of *death, suicide, sorrow* and *grief*. Although she submits to the bitter pressures of her father, she realises that she cannot let her father go, even if she is crushed under the burden of a poor quality life. Sylvia tries to swim on her father's unruly shores, knowing that she will drown. This futile Endeavour arouses in her the desire to rebel. He saw his father as a German soldier and himself.

Introduction

Awarded the Pulitzer Prize posthumously in 1982 for her *Collected Poems*, Sylvia Plath's "Daddy", written in 1962, which appears in this collection, is perhaps her best known poem. It has elicited a variety of critical reactions, from feminist praise for its unadulterated rage towards male dominance, to wariness in its usage of Holocaust imagery. It has been reviewed and criticized by scores of scholars, and is upheld as one of the best examples of confessional poetry. Written a few months before her suicide, "Daddy" gives a voyeuristic view of Plath's life as she skillfully combines the personal and the private with the historical to mount a brutal and venomous attack on her father Otto Plath and, indirectly on her husband, Ted Hughes.

Longing to be free

As Sylvia Plath is acknowledged to be a major confessional poet it follows that "Daddy" has autobiographical elements in it. It is therefore essential to know something about her father and the overpowering influence he had on her. Otto Plath immigrated to America from Grabow, a town in the Polish Corridor. He was a Professor of Biology in the University of Boston and died of diabetes when Sylvia Plath was nine. Sylvia, who hero-worshipped her father, never wholly recovered from this emotional loss. For this supposed act of desertion and betrayal she attacked him in several poems. While in her earlier poems her rage was turned inwards resulting in bitter self-reproach, in her later ones she directly attacked her father since her love for him was mingled with sadomasochistic feelings: ... He was an autocrat... I adored and despised him, and I probably wished many times that he were dead. When he obliged me and died, I imagined that I had killed him. (Ramazani 1143 – 1144).

It is an oft-reiterated point that the blending of the personal with the Holocaust has given this poem the reputation of being the 'Guernica' of modern poetry and why Plath does so needs to be understood.



மொழி

பதிப்பாசிரியர்
முனைவர் K. ரேவதி



978-93-6255-795-7

நூல்

மொழி

பதிப்பாசிரியர்

முனைவர் க. ரேவதி

மொழி

தமிழ்

பதிப்பு

2023

வெளியீடு

பதிப்பகம்

தமிழாய்வுத்துறை ,
பொன்னையா இராமஜெயம் நிகர்நிலை பல்கலைக்கழகம் ,
வல்லம், தஞ்சாவூர்- 61340.

பொருளடக்கம்

| | | |
|----|---|----|
| 1. | தமிழ் செம்மொழி முனைவர் சு.அழகிரிசாமி | 2 |
| 2. | தமிழ் முனைவர் மு.மலர்க்கொடி | 6 |
| 3. | தமிழ்ப் பண்பாட்டு வரலாற்று மூலங்கள் முனைவர் சே.சுகந்தி | 8 |
| 4. | மொழியும் சமயமும் அடையாளங்கள் முனைவர் க.அறிவுக்கனி | 16 |
| 5. | சமுதாயமும் பண்பாடும் முனைவர் K.காளீஸ்வரி | 23 |
| 6. | தமிழ் - ஓர் உயர்தனிச் செம்மொழி. திருT. கலியமூர்த்தி | 26 |
| 7. | மனிதமொழி முனைவர் சு.சதீஸ்வரன் | 34 |

தமிழ் செம்மொழி

முனைவர் சு.அழகிரிசாமி
உதவிப் பேராசிரியர், தமிழ்த்துறை
பொன்னையா இராமஜெயம் நிகர்நிலை
பல்கலைக்கழகம் வல்லம், தஞ்சாவூர்

இந்தியாவில் சம்ஸ்கிருதம் செம்மொழியாக கருதப்பட்டு அரசின் பல சலுகைகளை அனுபவித்து வந்தாலும், இந்தியாவில் அதிகாரபூர்வமாக செம்மொழி என அறிவிக்கப்பட்ட முதல் மொழி தமிழ்தான்.

தமிழை செம்மொழியாக அறிவிக்கும் முடிவை காங்கிரஸ் தலைமையிலான ஐக்கிய முற்போக்கு கூட்டணி அரசின் அமைச்சரவை 2004 செப்டம்பர் 17ம் தேதி எடுத்தது. அந்த முடிவை மத்திய தகவல் ஒளிபரப்புத் துறை அமைச்சர் ஜெய்பால் ரெட்டி அறிவித்தார்.

இந்தக் கோரிக்கையை பலகாலம் வலியுறுத்தி வென்ற அப்போதைய தமிழக முதல்வர் கருணாநிதி, பல காலமாக இதற்காக வாதாடிய பரிதிமாற்கலைஞர் போன்ற அறிஞர்களுக்கு இந்த வெற்றியை அர்ப்பணிப்பதாக அறிவித்தார்.

ஆனால், தமிழை செம்மொழி என்று அறிவித்த மத்திய அரசு, அத்தோடு நிற்கவில்லை. செம்மொழி எவை என்பதற்கான ஒரு இலக்கணத்தையும் வகுத்து, அதன்கீழ் தகுதி பெறும் மொழிகள் செம்மொழிப்பட்டியலில் சேர்க்கப்படும் என்றும் அறிவித்தது.

தமிழை செம்மொழி ஆக்கவேண்டும் என்பது திமுக இடம் பெற்ற ஐக்கிய முற்போக்கு கூட்டணியின் குறைந்தபட்ச செயல்திட்டத்திலேயே இருந்தது. அந்த அரசின் முதல் நாடாளுமன்றக் கூட்டத் தொடரிலேயே ஜூன் 6-ம் தேதி தமிழ் செம்மொழிக்கான அறிவிப்பு வெளியிடப்பட்டது. இந்த நாள் செம்மொழி தினமாக கொண்டாடப்படுகிறது.

அதன் அடிப்படையில் அடுத்தடுத்த ஆண்டுகளில் சம்ஸ்கிருதம், கன்னடம், தெலுங்கு, மலையாளம், ஒடியா ஆகிய மொழிகளும் செம்மொழிப் பட்டியலில் சேர்க்கப்பட்டன. மராத்தியை செம்மொழி என அறிவிப்பதற்கான முயற்சிகள் நடந்து வருகின்றன.

தமிழ்

முனைவர் மு.மலர்க்கொடி
உதவிப் பேராசிரியர், தமிழ்த்துறை
பொன்னையா இராமஜெயம் நிகர்நிலை
பல்கலைக்கழகம் வல்லம், தஞ்சாவூர்

முன்னுரை

இலக்கியமும், இலக்கணமும் கொண்டு காலத்தை வென்று பல்வேறு நூற்றாண்டுகள் கடந்து இன்றும் இனிமை குறையாமல் கற்போர் நெஞ்சத்தை நெகிழ்ச்சி செய்யும் அருந்தமிழ் சிறப்பினை வார்த்தைகளால் சொல்ல இயலாது.

தமிழின் சிறப்பைப் போற்றி பாடியவர்கள் எண்ணிக்கை எண்ணில் அடங்கா. “தமிழுக்கும் அமுதென்று பேர் அந்தத் தமிழ் இன்பத் தமிழ் எங்கள் உயிருக்கு நேர்” என்று பாரதிதாசன் பாடியுள்ளார்.

யாமறிந்த மொழிகளிலே தமிழ் மொழி போல் இனிதாவது எங்கும் காணோம்” என்று பாரதியார் கூறுகின்றார். இத்தகைய தமிழ் மொழியின் சிறப்புக்கள் பற்றி இக்கட்டுரையில் காண்போம்.

தமிழ் மொழியின் தொன்மை

செம்மொழியாகத் தமிழ் உயர்ந்து நிற்பதற்கு முக்கிய காரணம் அதன் தொன்மைத் தன்மையே ஆகும். தமிழ்மொழி மிக நீண்ட நெடிய வரலாற்றை அடிப்படையாகக் கொண்டது.

உலகில் பல மொழிகள் தோன்றி மறைந்தொழிந்தன என மொழியியல் அறிஞர்கள் கருத்துத்துரைத்துள்ளனர். கால மாற்றத்திற்கேற்ப புத்தம் புது மொழிகளும் தோன்றி வளர்ந்து வருகின்றன.

தமிழ்ப் பண்பாட்டு வரலாற்று மூலங்கள்

முனைவர் சே.சுகந்தி
உதவிப் பேராசிரியர், தமிழ்த்துறை
பொன்னையா இராமஜெயம் நிகர்நிலை
பல்கலைக்கழகம் வல்லம், தஞ்சாவூர்

தமிழ்நாட்டின் பண்பாட்டையும் வரலாற்றையும் காட்டும்

மூலச்சான்றுகள் பல உள்ளன.

1. இலக்கியப் பதிவுகள்
2. கல்வெட்டுகள்
3. அகழ்வாய்வுகள்
4. அயலகப் பயணிகளின் குறிப்புகள்

என்பவை இந்த வகையில் முக்கியமானவை. இவற்றை ஆதாரங்களாகக் கொண்டு தமிழகப் பண்பாட்டையும் வரலாற்றையும் மீட்டுருவாக்கம் (Reconstruction) செய்ய இயலும்.

மொழியும் சமயமும் அடையாளங்கள்

முனைவர் க.அறிவுக்கனி
உதவிப் பேராசிரியர், தமிழ்த்துறை
பொன்னையா இராமஜெயம் நிகர்நிலை
பல்கலைக்கழகம் வல்லம், தஞ்சாவூர்

பக்தி இயக்கம்

தமிழ் இலக்கிய வரலாற்றில் கி.பி. ஆறாம் நூற்றாண்டு முதல் பன்னிரண்டாம் நூற்றாண்டு வரையிலான காலகட்டத்தைத் தமிழ் பக்தி இயக்கத்தின் பொற்காலம் எனக் குறிப்பிடலாம். இக்காலக் கட்டத்தில்தான் பக்தி இயக்கம் தமிழகத்தில் தோன்றி மெல்ல மெல்ல வடபுலம் நோக்கிப் பெயர்ந்து உலகளாவிய இயக்கமாகப் பரவியது.

பக்தி இயக்கத்திற்கு வித்திட்ட பெருமை தமிழகத்திற்கு உரியது. அதற்கு உயிருட்டியவர்கள் நாயன்மார்களும் ஆழ்வார்களும் ஆவர். நாயன்மார்களில் முன்னின்றவர்கள் இருவர். ஒருவர் திருநாவுக்கரசர் மற்றவர் திருஞான சம்பந்தர். இவ்விருவரின் அடியொட்டியே ஏனைய நாயன்மார்கள் பக்தி இயக்கத்திற்கு உரம் ஊட்டினார்கள். கி.பி. 12ஆம் நூற்றாண்டில் தோன்றிய தெய்வச் சேக்கிழார் பக்தி

சமுதாயமும் பண்பாடும்

முனைவர் K.காளீஸ்வரி
உதவிப் பேராசிரியர், தமிழ்த்துறை
பொன்னையா இராமஜெயம் நிகர்நிலை
பல்கலைக்கழகம் வல்லம், தஞ்சாவூர்

சமுதாயமும் பண்பாடும்

அறிவியல் கண்டுபிடிப்புகளாலும், அரசியல், சமூக மாற்றங்களினாலும் உலகம் முழுவதும் பல மாற்றங்கள் ஏற்பட்டுள்ளன. இருப்பினும், சில நாடுகள், தங்களது, பண்பாடுகளைத் தனித் தன்மையுடன் பாதுகாத்து வருகின்றன. எடுத்துக்காட்டாக, திபேத்திலுள்ள திபேத்தியர்கள், தங்கள் பழைய பண்பாட்டை, இன்றைக்கும் தனித்தன்மை கெடாதவாறு பாதுகாத்து வருகின்றனர்.

பன்முகப் பண்பாடு (Multiculture)

இங்கிலாந்து, அமெரிக்கா போன்ற முன்னேறிய நாடுகளிலும், வணிகம், அலுவலகப்பணி ஆகியவை மிகுந்த நகரங்களிலும் பல நாட்டவர்களும், பல மாநிலத்தவரும் வந்து குடியேறியமையால், பல நாட்டுப் பண்பாடுகளும் கலந்துள்ளன. எனவே, பல நாட்டுப் பண்பாடுகளின் சங்கமமாக, அந்த நாடுகளின் பண்பாடுகள் அமைந்துள்ளன. எனவே, அத்தகைய பண்பாட்டைப் பன்முகப் பண்பாடு என்று அழைக்கின்றனர்.

தமிழ் – ஓர் உயர்தனிச் செம்மொழி.

திரு T. கலியமூர்த்தி
உதவிப் பேராசிரியர், தமிழ்த்துறை
பொன்னையா இராமஜெயம் நிகர்நிலை

பல்கலைக்கழகம் வல்லம், தஞ்சாவூர்

உயர்தனிச் செம்மொழி என்னும் தொடரில் மூன்று அடைமொழிகள் உள்ளன. உயர், தனி, ;செம் என்பனவே அந்த அடை ;மொழிகள். உயர்ந்தமொழி, தனித்த மொழி, செம்மையான மொழி எதுவோ அதுவே உயர்தனிச் செம்மொழியாகும். உயர்வுத் தன்மை, தனித்தன்மை, செம்மைத் தன்மை ஆகிய மூன்று தன்மைகளையும் கொண்ட மொழியாக நம் தாய்மொழி தமிழ் இருப்பதை இங்கே பார்ப்போம்.

சொல் வளம் –

ஒரு மொழிக்கு உயர்வு அம்மொழியிலுள்ள சொல்வளத்தைப் பொறுத்தே அமையும். கருத்துகளைப் பரிமாறிக் கொள்ள உதவும் கருவியே மொழி. கருத்துகளைச் சொற்றொடர்கள் வழியாகவே உணர்த்துகிறோம். சொற்றொடர்களே சொற்களால்தான் உருவாகின்றன. எனவே மொழிக்கு அடிப்படையாக அமைவன சொற்களே. ஆ, ஈ, வா, போ முதலிய ஒரெழுத்துச் சொற்கள் தமிழில் 50க்கு மேல் உள்ளன. ஒரெழுத்து முதல் ஈரெழுத்து வரையில் ஆன தமிழ்ச் சொற்கள் ஏறத்தாழ நூறாயிரத்திற்கு மேல் உள்ளன. இவை எழுத்தின் சுருக்கத்தையும் சொல்லின் பெருக்கத்தையும் மொழியின் வளத்தையும் காட்டும் இயல்புடையவை.

தமிழில் ஒரு பொருள் என்னும் நிலை மட்டுமல்லாது பல பொருள் உணர்த்தும் ஒருசொல் நிலை பல உண்டு. மா என்னும் சொல்லுக்குப் பெரிய, மாவு, மாமரம், குதிரை, விலங்கு, இலக்குமி எனப் பல பொருள் உண்டு. இவ்வாறே ஒருபொருள் உணர்த்தும் பல சொற்கள் இருப்பதைப் பார்க்கலாம். கூறினான், சொன்னான், பேசினான், செப்பினான்,

உதவிப் பேராசிரியர், தமிழ்த்துறை
பொன்னையா இராமஜெயம் நிகர்நிலை
பல்கலைக்கழகம் வல்லம், தஞ்சாவூர்

மொழியியல் (*Linguistics*) என்பது மொழியை^[1] அறிவியல் முறைப்படி^[2] ஆராய்வதற்குரிய ஒரு துறையாகும். மொழியின் வடிவம், பொருள், சூழல் போன்றவற்றையும் மொழியியல் ஆய்வு செய்கிறது^[3]. பொதுவான சகாப்தத்திற்கு முந்திய 4 ஆம் நூற்றாண்டில் இந்திய இலக்கண அறிஞரான பாணிணி சமசுகிருத மொழியைப்பற்றி ஒரு முறையான ஆய்வு விளக்கத்தை எழுதியுள்ளார்^{[4][5][6]}.

மொழியியலாளர்கள் சொற்களின் ஒலி மற்றும் பொருளுக்கு இடையிலான ஒர் ஒற்றுமையைக் கவனிப்பதன் மூலம் பாரம்பரியமாக மனித மொழியை பகுப்பாய்வு செய்கின்றனர்^[7]. ஒலிப்பியல் என்பது பேச்சு மற்றும் உரையாடல் ஒலிகளைப் பற்றிய ஆய்வு ஆகும், மேலும் இது அவர்களின் ஒலி தொடர்பான மற்றும் ஒலிகளை தெளிவாக உச்சரிப்பதற்குரிய உச்சரிப்பொலியியல் பண்புகளுக்குள்ளும் நுழைகிறது. மறுபுறம், மொழியின் அர்த்தத்தை ஆய்வு செய்து உலகின் பிற கூறுகள், பண்புகள் மற்றும் உலகின் பிற அம்சங்கள் ஆகியவற்றிற்கு இடையேயான உறவுகளை எவ்வாறு புரிந்துகொள்வது, செயல்படுத்துவது மற்றும் பொருளை வழங்குவது, அத்துடன் எவ்வாறு நிர்வகிப்பது, தோன்றும் கருத்து மயக்கத்தை எவ்வாறு தீர்ப்பது ஆகியவற்றைப் பற்றியும் மொழியியல் பேசுகிறது^[8]. அதேவேளையில் சொற்பொருள்களைப்பற்றிய ஆய்வு, சூழல் எவ்வாறு மொழிக்கான பொருளை உருவாக்குகிறது என்ற உண்மை நிலையையும் ஆராய்வதை மொழியியல் நடைமுறையாகக் கொண்டுள்ளது^[9].

இலக்கணம் என்பது ஒரு மொழியில் சொற்களின் உற்பத்தி மற்றும் பயன்பாட்டை நிர்வகிக்கும் விதிமுறைகள் தொடர்பான நடைமுறையாகும். இவ்விதிமுறைகள் ஒலிகளுக்கும்^[10] அவை தரும் பொருளுக்கும் பொருந்தும். மேலும், ஒலிக்கும் ஒலியமைப்புகளின் அமைப்பு சார்ந்த குரலியல், சொற்களின் அமைப்பு மற்றும் உருவாக்கம் சார்ந்த உருபனியல், சொற்றொடர்கள் உருவாக்கம் மற்றும் அமைப்பு சார்ந்த தொடரியல் உள்ளிட்டவற்றின் உட்கூறுகள் சார்ந்த துணைவிதிகளையும் இலக்கணம் வரையறை செய்கிறது^[11]. இலக்கணத்தின் கொள்கைகளில் நவீன இலக்கணக் கோட்பாடுகள் கவனம் செலுத்துகின்றன. இவை பெரும்பாலும் நோம் சோம்சுகியின் சித்தாந்தக் கல்வியின் பொது இலக்கணத்தை அடிப்படையாகக் கொண்டுள்ளன. [

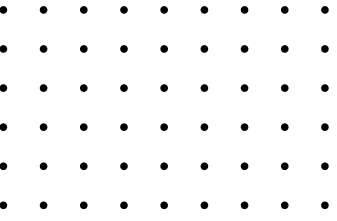

ESSENTIAL CELL BIOLOGY



**Edited by
DR.G.SRITHAR**



978-93-6255-386-7

Essential Cell Biology

Copyright © 2023 by Dr. G. Srithar

All rights reserved. No part of this book may be reproduced or transmitted in any form or by any means without written permission from the author.

ISBN: 978-93-6255-386-7



Publisher: Ponnaiyah Ramajayam Institute of Science and
Technology (PRIST)

TABLE OF CONTENTS

| | | |
|--|-----------------------------------|-----|
| Chapter 1 <i>Cell Membranes</i> | Dr. A. SHAJAHAN | 1 |
| Chapter 2 <i>Ionophores in Planar Lipid Bilayers</i> | Dr. S. AMBIGA | 16 |
| Chapter 3 <i>Cell Structure</i> | Dr. ARJUNPANDIAN | 44 |
| Chapter 4 <i>Signal Transduction and Second Messengers</i> | Dr. C. ANUSHIA | 67 |
| Chapter 5 <i>Calcium as an Intracellular Second Messenger: Mediation by Calcium-Binding Proteins</i> | Dr. T. GUNASEELAN | 98 |
| Chapter 6 <i>Intracellular Chloride Regulation</i> | Dr. G. SRITHAR | 122 |
| Chapter 7 <i>Osmosis and Regulation of Cell Volume</i> | Dr. A. BAKRUDEEN ALI AHMED | 145 |

Chapter 1

Cell Membranes

Dr. A. SHAJAHAN

Department of Biotechnology, School of Arts and Sciences, PRIST Deemed University, Thanjavur, Tamil Nadu, India.

INTRODUCTION

Tobacco smoking is the predominant cause of lung cancer, and it has been estimated that about 80% of lung cancers are attributed to smoking (Buiatti et al., 1996). As a complement to smoking cessation in lung cancer prevention, considerable attention has been focused on possible protective factors in the diet. A diet rich in fruits and vegetables has rather consistently been reported to be associated with a reduced risk of lung cancer (Ziegler et al., 1996). Several plausible mechanisms have been suggested, indicating that this reduction may be due to antioxidant micronutrients (Dorgan and Schatzkin, 1991). Thus far considerable attention has been directed to β -carotene, but intervention trials have not confirmed the presence of a protective effect (Albanes et al., 1996; Hennekens et al., 1996; Omenn et al., 1996). Some evidence also suggests that the reduced risk of lung cancer associated with the intake of fruits and vegetables may be due to some other micronutrients, such as vitamin C (Block et al., 1992), flavonoids (Knekt et al., 1997a), and selenium (Clark et al., 1996). The epidemiological evidence is, however, not yet persuasive for any of these, while the question of whether lung cancer can be prevented or slowed down by the antioxidant vitamin E has also been addressed in a number of studies (Knekt, 1994). The aim of this chapter is to review findings from epidemiological studies on the role of vitamin E in cancer prevention and to present some new results from the Finnish Mobile Clinic Health Examination Survey.

REVIEW OF STUDIES

Study Designs and Study Populations

Two intervention trials and 25 observational studies on the association between vitamin E status and lung cancer risk are considered here. In an intervention trial the investigator randomly assigns vitamin E or placebo to the study population and then waits for the

Chapter 2

Ionophores in Planar Lipid Bilayers

Dr. S. AMBIGA

Department of Biochemistry, School of Arts and Sciences, PRIST Deemed University, Thanjavur, Tamil Nadu, India.

INTRODUCTION

There are currently 3 million tobacco-related deaths in the world each year, and in general smokers can expect to live 7 years less than nonsmokers (World Health Organisation, 1977). This premature mortality is because habitual smoking is associated with an increased risk of developing many diseases, including coronary heart disease, lung cancer, stroke, and emphysema (Health Education Authority, 1992). Paradoxically, analysis across countries reveals little relationship between smoking levels and mortality from diseases such as coronary heart disease and cancer. For example, Japan has one of the lowest incidences of lung cancer in the world despite having one of the highest per capita consumption of cigarettes (Diana, 1993). Similarly, coronary heart disease rates in countries such as Greece and Spain are low despite very high cigarette usage (Fig. 1). This suggests that indigenous factors within countries such as diet may modify the risk of developing smoking-related diseases. Many of the clinical conditions implicated with smoking are also associated with increased indices of free radical-mediated damage to proteins, lipids, and DNA (Duthie and Arthur, 1994), indicating that smoking may exacerbate the initiation and propagation of oxidative stresses, which are potential underlying processes in the pathogenesis of many diseases (Diplock, 1994).

SMOKING AS AN OXIDATIVE STRESS

Smokers inhale large amounts of reactive free radicals arising from the combustion of tobacco. The tar in cigarettes contains more than 10¹⁷ stable long-lived quinone-semiquinone radicals per gram, which are generated by the oxidation of polycyclic aromatic hydrocarbons during the combustion process. These can reduce oxygen to superoxide and hydrogen peroxide and result in the production of the highly reactive hydroxyl radical. The gas phase smoke contains more than 10¹⁰ free radicals per puff of shortlived, reactive carbon- and oxygen-centered peroxy species. These can achieve in the field polycyclic aromatic hydrocarbons.

Chapter 3

Cell Structure

Dr. Arjunpandian

Department of Biotechnology, School of Arts and Sciences, PRIST Deemed University, Thanjavur, Tamil Nadu, India.

INTRODUCTION

We are at the threshold of the second revolution in our understanding of the role of nutrition in disease and health. The first revolution took place early in this century, with the discovery of the frank nutrient deficiency diseases and their causes. As a result of that research in the nutritional sciences, we essentially eliminated beriberi, pellagra, rickets, and goiter. We did so, incidentally, not by education but by fortification.

Today we are at the threshold of an even greater revolution, and it involves the antioxidant nutrients, including vitamin C, vitamin E, and the carotenoids. Increasingly, research suggests that these nutrients are of great importance in reducing the risk of cancer and heart disease, the two major killers in Western society. However, beyond these diseases, it is increasingly apparent that antioxidants may be important in most of the diseases of aging, including age-related eye diseases such as cataracts, and impaired immune function resulting in increased susceptibility to infection.

Evidence for an important role for antioxidant nutrients comes from the complete spectrum of biomedical research fields, from biochemical research, animal studies, epidemiologic data, and clinical trials. Any one of these alone would be insufficient as a basis for public policy.

LABORATORY AND ANIMAL DATA ON OXIDATION AND ANTIOXIDANTS

Oxidation

Oxidation is the transfer of electrons from one atom to another. It is an essential part of normal metabolism. The process of extracting energy from food involves the transfer of electrons, with release of energy at each step, through a series of electron acceptors until

Chapter 4

Signal Transduction and Second Messengers

Dr. C. ANUSHIA

Department of Biotechnology, School of Arts and Sciences, PRIST Deemed University, Thanjavur, Tamil Nadu, India.

I. INTRODUCTION

25-Hydroxyvitamin D (25OHD)* is the first hydroxylated metabolite of vitamin D (D) and the immediate precursor of the fully active and hormonal form of the vitamin, $1\alpha,25$ -dihydroxyvitamin D [$1,25(\text{OH})_2\text{D}$]. It was discovered by DeLuca and his group, who rapidly identified the liver as the first site of activation of D₃ [1–3]. Over the past 35 years, the enzyme systems involved in the C-25 hydroxylation of D₃, D₂, and several of their analogs have been the object of intense studies by groups in North America, Europe, and Japan. The research has allowed the identification of two intrahepatic organelles, the smooth endoplasmic reticulum (microsomes) and the mitochondrion, as sites possessing fully active but distinct D 25-hydroxylases.

The mitochondrial enzyme has been cloned [4–6] and its identity as a D₃ 25-hydroxylase established with certainty. Moreover, its presence and activity has been positively identified in all species studied including the human [7]. The microsomal enzyme received the attention of early workers in the field. It has been identified clearly in the pig, where the enzyme has been cloned and clearly shown to hydroxylate D₃ and D₂ at C-25 [8]. Lately, a new microsomal D 25-hydroxylase species has also been cloned and its gene transcript shown to be present in mice and humans [9]. The latter is also reported to be active in the C-25 hydroxylation of both D₃ and D₂. In most species, early work has shown that the microsomal D₃ 25-hydroxylase is an enzyme also active in the oxidation of several endogenous and exogenous substances and, based on the enzyme kinetics of the respective microsomal and mitochondrial enzymes, believed by many to be more physiologically relevant than the mitochondrial entity. In this chapter, we review the most relevant research area on the D 25-hydroxylases and address the specificity and regulation of each enzyme in

Chapter 5

Calcium as an Intracellular Second Messenger: Mediation by Calcium-Binding Proteins

Dr. T. GUNASEELAN

Department of Biochemistry, School of Arts and Sciences, PRIST Deemed University,
Thanjavur, Tamil Nadu, India.

I. OCCURRENCE AND CHARACTERISTICS OF 25-HD3 1 α -HYDROXYLASE

A. The Kidney as the Source of Circulating 1 α ,25(OH)₂D₃ It is now well accepted that vitamin D is a precursor of the sterol hormone 1 α ,25-dihydroxyvitamin D₃ [1 α ,25(OH)₂D₃]. The general pathway of production of 1 α ,25(OH)₂D₃ is shown in Fig. 1. It has been appreciated for some time [1,2] that the kidney is the major site of production of circulating 1 α ,25(OH)₂D₃, although as described later and discussed more thoroughly elsewhere in this volume, many other tissues and cell types have been shown to produce 1 α ,25(OH)₂D₃ from 25-hydroxyvitamin D₃ (25OHD₃). Within the kidney, it was established early on by microdissection studies that in the fetal rabbit [3] and in the vitamin D-deficient rat [4] and chick [5], the proximal tubules are the region of the most robust activity of the 1 α -hydroxylase. With the cloning of the cDNA for the cytochrome P450 component of the 1 α -hydroxylase (see Section III) has come the ability to measure its mRNA and protein levels along the nephron. Since these determinations are more sensitive than the measurement of enzyme activity, localization studies can now be carried out under conditions of vitamin D sufficiency and normal mineral status.

Thus in vitamin D-sufficient mice and humans, mRNA and/or protein has been identified by in situ hybridization or immunohistochemical staining in the more distal portions of the nephron along with relatively low expression in the proximal tubules [6,7]. These observations suggest that, while the 1 α -hydroxylase occurs throughout the nephron, its regulation varies such that the effects of vitamin D status and abnormal phosphorus metabolism (see Section IV) occur primarily if not exclusively in the proximal tubules. In situ hybridization studies of cultures of embryonic mouse kidneys confirm the presence of 25OHD₃ 1 α -hydroxylase (CYP1 α) in tubular epithelium, but not collecting ducts or glomeruli [8]. Along with the demonstration that the kidney contained the enzymatic capability to produce 1 α ,25(OH)₂D₃ other work was suggesting that this metabolic step was largely confined to this organ.

Chapter 6

Intracellular Chloride Regulation

Dr. G. SRITHAR

Department of Biochemistry, School of Arts and Sciences, PRIST Deemed University, Thanjavur, Tamil Nadu, India.

I. BACKGROUND

A. Enzyme Function and Regulated Expression Vitamin D is a secosteroid whose biological function is dependent upon its metabolic activation and turnover. These metabolite pathways contain specific hydroxylase enzymes that are members of the cytochrome P450 superfamily of mixed-function monooxygenases. Bioactivation of vitamin D involves the sequential actions of 25-hydroxylase and 1-hydroxylase enzymes leading to the synthesis of the hormonally active secosteroid 1,25-dihydroxyvitamin D [1,25(OH)₂D]* (Fig. 1). These two enzymes are discussed in Chapter 4 (vitamin D 25-hydroxylase) and Chapter 5 (25-hydroxyvitamin D 1 α -hydroxylase) and will be mentioned in this chapter only on a comparative basis to 25-hydroxyvitamin D- 24(R)-hydroxylase cytochrome P450c24 (CYP24), the enzyme that directs the side-chain metabolism of 25-hydroxylated vitamin D metabolites, which leads to their terminal physiological inactivation and turnover.

Most cellular actions of vitamin D are mediated through the secosteroid hormone 1,25(OH)₂D and involve the transcription of vitamin D-dependent genes. These regulatory processes involve the coordinated modulation and coupling of rapid signal-transduction pathways with slower acting ligand-dependent transcription factors [1]. In both cases, the secosteroid ligand binds to a ligand-specific receptor. The rapid response receptor is located in the cellular membrane of target tissues and initiates rapid signaling responses through a receptor that has been referred to as the membrane-associated receptor membrane-associated rapid response steroid (MSSRS) receptor complex [2,3]. The hormone receptor for the transcription process involves the nuclear vitamin D receptor (nVDR), which is a ligand-dependent transcription factor that functions as a VDR:1,25(OH)₂D heterodimeric complex with the cis-retinoic acid: RXR complex (i.e., VDR-RXR) to regulate vitamin D-dependent genes associated with development and homeostasis (see Chapters 13–17 for details). Cellular and ambient levels 1,25(OH)₂D are regulated through the hormone's synthesis and degradation. The

Chapter 7

Osmosis and Regulation of Cell Volume

Dr. A. BAKRUDEEN ALI AHMED

Department of Biochemistry, School of Arts and Sciences, PRIST Deemed University, Thanjavur, Tamil Nadu, India.

Too much selenium (Se) in the diet is detrimental to animal health. The most toxic compounds are Se inorganic salts and Se methionine, which are found in water and plants. However, low soil content results in deficiency syndromes. In humans, clinical manifestations of deficiency are Keshan's disease, a severe cardiomyopathy, Kashin-Beck disease, an osteoarthropathy (1), and cretinism, when associated with an iodine deficiency (2). The eradication of Keshan disease by dietary Se supplementation (3, 4) further strengthened the correlation between low soil content and the disease. Interestingly, however, other complicating factors, such as viruses, have been implicated to explain the seasonal recurrence of this disease (5, 6). To this end, the induction of virulence in certain viruses by selenodeficiency, as documented for the human Coxsackievirus B3, which becomes virulent after the infection of Se-deficient mice and maintains its virulence in normal animals (7-9), is one of the most important aspects of recent selenium research. This observation might provide a rationale for the evidence that different diseases are due to the deficiency of the same element and it may also be relevant for cancer research. Furthermore, in vitro experiments suggest a role for Se in atherosclerosis or aging (10), but convincing epidemiological studies of this aspect are still missing.

Historically, knowledge of the beneficial effects of Se has come from livestock. It is well known that, together with vitamin E, Se supplementation prevents liver necrosis, degeneration of skeletal and cardiac muscles, reduced growth rate, and infertility in cattle (1). This last aspect has been clarified in recent years by well-documented nutritional studies. In selenodeficiency, selenium levels decrease in other organs, but not in testis (11), suggesting that this element may have a peculiar function. Furthermore, with the progression of the deficiency, various degrees of degeneration appear in the seminiferous epithelium, first involving only the mitochondria of spermatids and spermatozoa (12), resulting in a complete disappearance of mature germinal cells (13).



HEALTH AND ILLNESS IN PHYSIOLOGY

EDITED BY

DR. SASIKUMAR PONNUSAMY



978-93-6255-490-1

Health and illness in Physiology

Copyright © 2023 by Dr. Sasikumar Ponnusamy

All rights reserved. No part of this book may be reproduced or transmitted in any form or by any means without written permission from the author.

ISBN: 978-93-6255-490-1



Publisher: Ponnaiyah Ramajayam Institute of Science and Technology (PRIST)

TABLE OF CONTENTS

| | | |
|---|---------------------------------------|-----|
| Chapter 1 <i>Nanomedicine, Diagnostics and Drug Delivery</i> | Dr. A. SHAJAHAN | 1 |
| Chapter 2 <i>Nanoscience and Nanotechnology</i> | Dr. S. AMBIGA | 26 |
| Chapter 3 <i>Cellular Functions and Metabolism</i> | Dr. ARJUNPANDIAN | 54 |
| Chapter 4 <i>Organs, Organ Systems, and their Level of Organization</i> | Dr. C. ANUSHIA | 87 |
| Chapter 5 <i>Regenerative Medicine</i> | Dr. T. GUNASEELAN | 138 |
| Chapter 6 <i>Synthesis of nanoparticles</i> | Dr. G. SRITHAR | 192 |
| Chapter 7 <i>Regulatory and Risk Issues</i> | Dr. A. BAKRUDEEN ALI AHMED | 230 |

Chapter 1

Nanomedicine, Diagnostics and Drug Delivery

Dr. A. SHAJAHAN

Department of Biotechnology, School of Arts and Sciences, PRIST Deemed University, Thanjavur, Tamil Nadu, India.

INTRODUCTION

Tobacco smoking is the predominant cause of lung cancer, and it has been estimated that about 80% of lung cancers are attributed to smoking (Buiatti et al., 1996). As a complement to smoking cessation in lung cancer prevention, considerable attention has been focused on possible protective factors in the diet. A diet rich in fruits and vegetables has rather consistently been reported to be associated with a reduced risk of lung cancer (Ziegler et al., 1996). Several plausible mechanisms have been suggested, indicating that this reduction may be due to antioxidant micronutrients (Dorgan and Schatzkin, 1991). Thus far considerable attention has been directed to β -carotene, but intervention trials have not confirmed the presence of a protective effect (Albanes et al., 1996; Hennekens et al., 1996; Omenn et al., 1996). Some evidence also suggests that the reduced risk of lung cancer associated with the intake of fruits and vegetables may be due to some other micronutrients, such as vitamin C (Block et al., 1992), flavonoids (Knekt et al., 1997a), and selenium (Clark et al., 1996). The epidemiological evidence is, however, not yet persuasive for any of these, while the question of whether lung cancer can be prevented or slowed down by the antioxidant vitamin E has also been addressed in a number of studies (Knekt, 1994). The aim of this chapter is to review findings from epidemiological studies on the role of vitamin E in cancer prevention and to present some new results from the Finnish Mobile Clinic Health Examination Survey.

REVIEW OF STUDIES

Study Designs and Study Populations

Two intervention trials and 25 observational studies on the association between vitamin E status and lung cancer risk are considered here. In an intervention trial the investigator randomly assigns vitamin E or placebo to the study population and then waits for the

Chapter 2

Nanoscience and Nanotechnology

Dr. S. AMBIGA

Department of Biochemistry, School of Arts and Sciences, PRIST Deemed University, Thanjavur, Tamil Nadu, India.

INTRODUCTION

There are currently 3 million tobacco-related deaths in the world each year, and in general smokers can expect to live 7 years less than nonsmokers (World Health Organisation, 1977). This premature mortality is because habitual smoking is associated with an increased risk of developing many diseases, including coronary heart disease, lung cancer, stroke, and emphysema (Health Education Authority, 1992). Paradoxically, analysis across countries reveals little relationship between smoking levels and mortality from diseases such as coronary heart disease and cancer. For example, Japan has one of the lowest incidences of lung cancer in the world despite having one of the highest per capita consumption of cigarettes (Diana, 1993). Similarly, coronary heart disease rates in countries such as Greece and Spain are low despite very high cigarette usage (Fig. 1). This suggests that indigenous factors within countries such as diet may modify the risk of developing smoking-related diseases. Many of the clinical conditions implicated with smoking are also associated with increased indices of free radical-mediated damage to proteins, lipids, and DNA (Duthie and Arthur, 1994), indicating that smoking may exacerbate the initiation and propagation of oxidative stresses, which are potential underlying processes in the pathogenesis of many diseases (Diplock, 1994).

SMOKING AS AN OXIDATIVE STRESS

Smokers inhale large amounts of reactive free radicals arising from the combustion of tobacco. The tar in cigarettes contains more than 10¹⁷ stable long-lived quinone-semiquinone radicals per gram, which are generated by the oxidation of polycyclic aromatic hydrocarbons during the combustion process. These can reduce oxygen to superoxide and hydrogen peroxide and result in the production of the highly reactive hydroxyl radical. The gas phase smoke contains more than 10¹⁰ free radicals per puff of shortlived, reactive carbon- and oxygen-centered peroxy species. These can achieve in the field polycyclic aromatic hydrocarbons.

Chapter 3

Cellular Functions and Metabolism

Dr. Arjunpandian

Department of Biotechnology, School of Arts and Sciences, PRIST Deemed University, Thanjavur, Tamil Nadu, India.

INTRODUCTION

We are at the threshold of the second revolution in our understanding of the role of nutrition in disease and health. The first revolution took place early in this century, with the discovery of the frank nutrient deficiency diseases and their causes. As a result of that research in the nutritional sciences, we essentially eliminated beriberi, pellagra, rickets, and goiter. We did so, incidentally, not by education but by fortification.

Today we are at the threshold of an even greater revolution, and it involves the antioxidant nutrients, including vitamin C, vitamin E, and the carotenoids. Increasingly, research suggests that these nutrients are of great importance in reducing the risk of cancer and heart disease, the two major killers in Western society. However, beyond these diseases, it is increasingly apparent that antioxidants may be important in most of the diseases of aging, including age-related eye diseases such as cataracts, and impaired immune function resulting in increased susceptibility to infection.

Evidence for an important role for antioxidant nutrients comes from the complete spectrum of biomedical research fields, from biochemical research, animal studies, epidemiologic data, and clinical trials. Any one of these alone would be insufficient as a basis for public policy.

LABORATORY AND ANIMAL DATA ON OXIDATION AND ANTIOXIDANTS

Oxidation

Oxidation is the transfer of electrons from one atom to another. It is an essential part of normal metabolism. The process of extracting energy from food involves the transfer of electrons, with release of energy at each step, through a series of electron acceptors until

Chapter 4

Organs, Organ Systems, and their Level of Organization

Dr. C. ANUSHIA

Department of Biotechnology, School of Arts and Sciences, PRIST Deemed University, Thanjavur, Tamil Nadu, India.

I. INTRODUCTION

25-Hydroxyvitamin D (25OHD)* is the first hydroxylated metabolite of vitamin D (D) and the immediate precursor of the fully active and hormonal form of the vitamin, $1\alpha,25$ -dihydroxyvitamin D [$1,25(\text{OH})_2\text{D}$]. It was discovered by DeLuca and his group, who rapidly identified the liver as the first site of activation of D₃ [1–3]. Over the past 35 years, the enzyme systems involved in the C-25 hydroxylation of D₃, D₂, and several of their analogs have been the object of intense studies by groups in North America, Europe, and Japan. The research has allowed the identification of two intrahepatic organelles, the smooth endoplasmic reticulum (microsomes) and the mitochondrion, as sites possessing fully active but distinct D 25-hydroxylases.

The mitochondrial enzyme has been cloned [4–6] and its identity as a D₃ 25-hydroxylase established with certainty. Moreover, its presence and activity has been positively identified in all species studied including the human [7]. The microsomal enzyme received the attention of early workers in the field. It has been identified clearly in the pig, where the enzyme has been cloned and clearly shown to hydroxylate D₃ and D₂ at C-25 [8]. Lately, a new microsomal D 25-hydroxylase species has also been cloned and its gene transcript shown to be present in mice and humans [9]. The latter is also reported to be active in the C-25 hydroxylation of both D₃ and D₂. In most species, early work has shown that the microsomal D₃ 25-hydroxylase is an enzyme also active in the oxidation of several endogenous and exogenous substances and, based on the enzyme kinetics of the respective microsomal and mitochondrial enzymes, believed by many to be more physiologically relevant than the mitochondrial entity. In this chapter, we review the most relevant research area on the D 25-hydroxylases and address the specificity and regulation of each enzyme in

Chapter 5

Regenerative Medicine

Dr. T. GUNASEELAN

Department of Biochemistry, School of Arts and Sciences, PRIST Deemed University, Thanjavur, Tamil Nadu, India.

I. OCCURRENCE AND CHARACTERISTICS OF 25-HD3 1 α -HYDROXYLASE

A. The Kidney as the Source of Circulating 1 α ,25(OH)₂D₃ It is now well accepted that vitamin D is a precursor of the sterol hormone 1 α ,25-dihydroxyvitamin D₃ [1 α ,25(OH)₂D₃]. The general pathway of production of 1 α ,25(OH)₂D₃ is shown in Fig. 1. It has been appreciated for some time [1,2] that the kidney is the major site of production of circulating 1 α ,25(OH)₂D₃, although as described later and discussed more thoroughly elsewhere in this volume, many other tissues and cell types have been shown to produce 1 α ,25(OH)₂D₃ from 25-hydroxyvitamin D₃ (25OHD₃). Within the kidney, it was established early on by microdissection studies that in the fetal rabbit [3] and in the vitamin D-deficient rat [4] and chick [5], the proximal tubules are the region of the most robust activity of the 1 α -hydroxylase. With the cloning of the cDNA for the cytochrome P450 component of the 1 α -hydroxylase (see Section III) has come the ability to measure its mRNA and protein levels along the nephron. Since these determinations are more sensitive than the measurement of enzyme activity, localization studies can now be carried out under conditions of vitamin D sufficiency and normal mineral status.

Thus in vitamin D-sufficient mice and humans, mRNA and/or protein has been identified by in situ hybridization or immunohistochemical staining in the more distal portions of the nephron along with relatively low expression in the proximal tubules [6,7]. These observations suggest that, while the 1 α -hydroxylase occurs throughout the nephron, its regulation varies such that the effects of vitamin D status and abnormal phosphorus metabolism (see Section IV) occur primarily if not exclusively in the proximal tubules. In situ hybridization studies of cultures of embryonic mouse kidneys confirm the presence of 25OHD₃ 1 α -hydroxylase (CYP1 α) in tubular epithelium, but not collecting ducts or glomeruli [8]. Along with the demonstration that the kidney contained the enzymatic capability to produce 1 α ,25(OH)₂D₃ other work was suggesting that this metabolic step was largely confined to this organ.

Chapter 6

Synthesis of nanoparticles

Dr. G. SRITHAR

Department of Biochemistry, School of Arts and Sciences, PRIST Deemed University, Thanjavur, Tamil Nadu, India.

I. BACKGROUND

A. Enzyme Function and Regulated Expression Vitamin D is a secosteroid whose biological function is dependent upon its metabolic activation and turnover. These metabolite pathways contain specific hydroxylase enzymes that are members of the cytochrome P450 superfamily of mixed-function monooxygenases. Bioactivation of vitamin D involves the sequential actions of 25-hydroxylase and 1-hydroxylase enzymes leading to the synthesis of the hormonally active secosteroid 1,25-dihydroxyvitamin D [1,25(OH)₂D]* (Fig. 1). These two enzymes are discussed in Chapter 4 (vitamin D 25-hydroxylase) and Chapter 5 (25-hydroxyvitamin D 1 α -hydroxylase) and will be mentioned in this chapter only on a comparative basis to 25-hydroxyvitamin D- 24(R)-hydroxylase cytochrome P450c24 (CYP24), the enzyme that directs the side-chain metabolism of 25-hydroxylated vitamin D metabolites, which leads to their terminal physiological inactivation and turnover.

Most cellular actions of vitamin D are mediated through the secosteroid hormone 1,25(OH)₂D and involve the transcription of vitamin D-dependent genes. These regulatory processes involve the coordinated modulation and coupling of rapid signal-transduction pathways with slower acting ligand-dependent transcription factors [1]. In both cases, the secosteroid ligand binds to a ligand-specific receptor. The rapid response receptor is located in the cellular membrane of target tissues and initiates rapid signaling responses through a receptor that has been referred to as the membrane-associated receptor membrane-associated rapid response steroid (MSSRS) receptor complex [2,3]. The hormone receptor for the transcription process involves the nuclear vitamin D receptor (nVDR), which is a ligand-dependent transcription factor that functions as a VDR:1,25(OH)₂D heterodimeric complex with the cis-retinoic acid: RXR complex (i.e., VDR-RXR) to regulate vitamin D-dependent genes associated with development and homeostasis (see Chapters 13–17 for details). Cellular and ambient levels 1,25(OH)₂D are regulated through the hormone's synthesis and degradation. The regulated 1 α -hydroxylase (i.e., P450c1 or CYP27B1) directs the hormone's biosynthesis.

Chapter 7

Regulatory and Risk Issues

Dr. A. BAKRUDEEN ALI AHMED

Department of Biochemistry, School of Arts and Sciences, PRIST Deemed University, Thanjavur, Tamil Nadu, India.

Too much selenium (Se) in the diet is detrimental to animal health. The most toxic compounds are Se inorganic salts and Se methionine, which are found in water and plants. However, low soil content results in deficiency syndromes. In humans, clinical manifestations of deficiency are Keshan's disease, a severe cardiomyopathy, Kashin-Beck disease, an osteoarthropathy (1), and cretinism, when associated with an iodine deficiency (2). The eradication of Keshan disease by dietary Se supplementation (3, 4) further strengthened the correlation between low soil content and the disease. Interestingly, however, other complicating factors, such as viruses, have been implicated to explain the seasonal recurrence of this disease (5, 6). To this end, the induction of virulence in certain viruses by selenodeficiency, as documented for the human Coxsackievirus B3, which becomes virulent after the infection of Se-deficient mice and maintains its virulence in normal animals (7-9), is one of the most important aspects of recent selenium research. This observation might provide a rationale for the evidence that different diseases are due to the deficiency of the same element and it may also be relevant for cancer research. Furthermore, in vitro experiments suggest a role for Se in atherosclerosis or aging (10), but convincing epidemiological studies of this aspect are still missing.

Historically, knowledge of the beneficial effects of Se has come from livestock. It is well known that, together with vitamin E, Se supplementation prevents liver necrosis, degeneration of skeletal and cardiac muscles, reduced growth rate, and infertility in cattle (1). This last aspect has been clarified in recent years by well-documented nutritional studies. In selenodeficiency, selenium levels decrease in other organs, but not in testis (11), suggesting that this element may have a peculiar function. Furthermore, with the progression of the deficiency, various degrees of degeneration appear in the seminiferous epithelium, first involving only the mitochondria of spermatids and spermatozoa (12), resulting in a complete disappearance of mature germinal cells (13).



BASIC OF MEDICAL PHYSIOLOGY

EDITED BY

DR. S. AMBIGA



978-93-6255-168-9

Basic of Medical Physiology

Copyright © 2021 by Dr. S. Ambiga

All rights reserved. No part of this book may be reproduced or transmitted in any form or by any means without written permission from the author.

ISBN: 978-93-6255-168-9



Publisher: Ponnaiyah Ramajayam Institute of Science and
Technology (PRIST)

TABLE OF CONTENTS

| | | |
|--|------------------------------------|------------|
| Chapter 1 Advances and Trends in Healthcare Technology | Dr. BINUGEOGE | 1 |
| Chapter 2 Diagnostic Imaging | Dr. S. SATHISHKUMAR | 18 |
| Chapter 3 Reconstruction Technologies for Medical Imaging Systems | Dr. A. SUNDARESAN | 41 |
| Chapter 4 Detectors for X-ray Imaging And Computed Technology | Dr. G. SRITHAR | 58 |
| Chapter 5 3D-Rotational X-ray Imaging | Dr. BAKRUDEEN ALI AHMED | 75 |
| Chapter 6 Coronary Magnetic Resonance Angiography | Dr. T. GUNASEELAN | 88 |
| Chapter 7 4-Dimensional Ultrasonic Imaging | Mr. R. VISWALINGAM | 102 |

Chapter 1

ADVANCES AND TRENDS IN HEALTHCARE TECHNOLOGY

Stopping Diseases Before They Start

Dr. BINUGEORGE

Department of Biochemistry, School of Arts and Sciences, PRIST
Deemed University, Thanjavur, Tamil Nadu, India

Abstract: This introductory chapter describes the drivers for recent and future changes in healthcare: (1) socio-economic developments in society (in particular the aging society and the growth of chronic disease), (2) the healthcare politics that these developments induce, and (3) advances in healthcare technology. Three major trends in healthcare technology are singled out: The impact of Moore's Law on medical imaging, molecular medicine, E-health and personal healthcare.

Keywords: Socio-economic developments, the aging society, chronic disease, healthcare politics, medical technology, advances in medical imaging, molecular medicine, E-health, personal healthcare

1. INTRODUCTION

Society today is in overdrive with no sign of braking or even slowing down. Time and speed are the key parameters guiding our path. From the era of the microsecond, we moved into the world of the nanosecond where everything goes so fast that its representation is frozen, it cannot be captured by the human eye. The Czech novelist, Milan Kundera, wrote: "Speed is the new ecstasy that technology has bestowed on man". By ecstasy, he meant a simultaneous state of both imprisonment and freedom. Man is caught in a fragment of time, totally disconnected from his past and his future. Nowadays there is often reference made to 'real time'. Does it mean that time was 'non-real'? The concept of real time first appeared in the mid 1950s, when mention was made of computers. But computers never dealt with real time, they dealt with simulated time in simulated realities. Only

Chapter 2

DIAGNOSTIC IMAGING

State-of-the-art and Recent Advances

Dr. S. SATHISHKUMAR

Department of Biochemistry, School of Arts and Sciences, PRIST
Deemed University, Thanjavur, Tamil Nadu, India.

Abstract: Medical imaging is the heart of many diagnostic and therapeutic procedures. Starting from the discovery of X-rays in 1895, a number of imaging modalities were invented and later established in clinical practice. Initially these imaging modalities (except PET and SPECT, which target metabolic processes) were aimed to visualize non-invasively anatomical details from within the body. With the improvement of imaging agents, computing power and imaging technology increasingly information about organ function and even metabolism can be measured and used in the clinical decision process. However, all established imaging modalities have strengths and weaknesses. Therefore, a strong trend exists to combine complementary information from different imaging modalities, either through system integration or software fusion. PET-CT is an impressive manifestation of this trend. In addition, work continues to explore novel imaging techniques with the aim to develop new modalities. These would help to close remaining clinical gaps with imaging as the enabler.

Keywords: Imaging modalities, hybrid imaging, functional imaging, molecular imaging, X-ray, CT, PET, SPECT, MR, ultrasound, optical imaging, photoacoustic tomography, magnetic particle imaging

1. INTRODUCTION

Radiology began as a medical sub-specialty in the first decade of the 1900's after the discovery of X-rays. The development of radiology grew at a moderate pace until World War II. Extensive use of X-ray imaging during the second world war, and the advent of the digital computer and new imaging modalities like ultrasound, computed tomography, magnetic resonance imaging and nuclear imaging have combined to create an

Chapter 3

RECONSTRUCTION TECHNOLOGIES FOR MEDICAL IMAGING SYSTEMS

Advances in Algorithms and Hardware for CT

Dr. A. SUNDARESAN

Department of Biochemistry, School of Arts and Sciences, PRIST
Deemed University, Thanjavur, Tamil Nadu, India.

Abstract: Medical imaging made immense advances in the last years. Beside new modalities the traditional imaging techniques and systems made rapid improvements. A good example is the improvements of Computerized Tomography (CT) with the introduction of large detector arrays. One of the important technological challenges of most medical imager is the reconstruction technology, which has to deal with complex imaging techniques and steadily increasing requirements. This chapter provides a brief insight into this field and discusses some technological aspects of reconstruction for CT.

Keywords: Reconstruction, CT, hardware acceleration

1. INTRODUCTION

Most medical imaging devices use physical interactions to generate spatially resolved maps of static properties or functional information. Sensors are used to measure an impact of these physical interactions. Only in few cases the detected signals represent the final images directly (e.g. X-Ray radiography). In most imaging devices, the detected data itself are not useful for medical diagnosis and are usually converted back to the spatially resolved physical effect in the object that causes the acquired signals. The functional chain from the physical interaction up to the detected signal is called the forward problem and is usually well understood. However, the forward problem can become very complex and can include a number of disturbing effects such as scatter radiation, noise, or imperfections of the medical imaging device. Reconstruction is the inversion of the forward

Chapter 4

DETECTORS FOR X-RAY IMAGING AND COMPUTED TOMOGRAPHY

Advances and Key Technologies

Dr. G. SRITHAR

Department of Biochemistry, School of Arts and Sciences, PRIST
Deemed University, Thanjavur, Tamil Nadu, India.

Abstract: Medical X-ray imaging and Computed Tomography (CT) rely heavily on the performance of the imaging detectors used in these modalities. This article gives an overview over the key technologies involved in the construction of such imaging detectors. Apart from the conversion of the X-rays also photodiodes and the associated electronics constitute important technology fields. For both X-ray and CT the development of the technologies over the last decade is reviewed, the state of the art is described and some current and envisaged developments are emphasized.

Keywords: X-ray, CT, detector, scintillator, direct conversion, photodiode, pixel electronics, integrating, counting

1. INTRODUCTION

Signal detectors are a central element in any medical imaging system. In the imaging modalities X-ray, CT, SPECT and PET the information is carried by ionizing radiation, more precisely X-rays or γ -quanta. The imaging detectors consist of a multitude of detector channels, for modern X-ray detectors up to several million picture elements (pixels). In this article, the main emphasis will be on detectors for X-ray and CT. SPECT and PET will be briefly touched upon in the outlook section at the end of the article.

In general, detectors for X-ray and CT imaging comprise a conversion stage for converting the X-ray quanta ultimately into electrical signals. The conversion stage is followed by pixel electronics, i.e. the electronic circuitry belonging exclusively to one detector channel. The pixel electronics are then

Chapter 5

3D-ROTATIONAL X-RAY IMAGING

Advances in Interventional Volume Imaging

Dr. A. BAKRUDEEN ALI AHMED

Department of Biochemistry, Research Development Cell (RDC), PRIST Deemed University, Thanjavur, Tamil Nadu, India.

Abstract: 3D-rotational X-ray imaging is a rather new volume imaging technique on conventional C-arm X-ray systems. This contribution covers the basics of the underlying mathematics of three-dimensional X-ray imaging, the data acquisition protocols, and calibration and reconstruction techniques. Furthermore, an overview of the current clinical application of 3D-rotational X-ray imaging is presented.

Keywords: 3D-rotational angiography, C-arm calibration, cone beam reconstruction

1. INTRODUCTION

Three-dimensional rotational X-ray imaging (3D-RX) is a rather new imaging method based on the rotational angiography (RA) technique, which was introduced in the early 90s. RA is an extension of the conventional angiography technique, in which the gantry of an X-ray system is rotated around the patient while acquiring X-ray projections during continuous contrast agent (CA) injection. Initially, the main application of RA was in the field of interventional neuroradiology^{1,2}. Compared to conventional angiography the improved visualization of vascular anatomy by the multiple angles of view available from the rotational acquisition results in superior information on complex 3D vascular structures. This additional anatomic information significantly improved e.g. the angiographic assessment of aneurysms making it an excellent adjunct in e.g. the investigation of subarachnoid hemorrhage. In the following years RA has been introduced to various other fields including assessment of the renal arteries^{3,4} and

Chapter 6

CORONARY MAGNETIC RESONANCE ANGIOGRAPHY

Methodological Aspects

Dr. T. GUNASEELAN

Department of Biochemistry, Research Development Cell (RDC), PRIST Deemed University, Thanjavur, Tamil Nadu, India.

Abstract: This chapter gives a brief overview over recent methodological advances of Coronary Magnetic Resonance Angiography (CMRA). To cope with the major problem of cardiac and respiratory motion, techniques for motion correction and appropriate data sampling schemes based on advanced hardware technology are discussed, and examples of CMRA data are shown.

Keywords: Magnetic resonance imaging, MRI, coronary artery imaging, navigator, motion, motion correction

1. INTRODUCTION

According to the WHO, coronary artery disease is the major cause of morbidity in the western civilisation. This is despite the recent improvements in diagnostic technology and the huge efforts spent on prevention. The gold standard for the diagnosis of this disease is x-ray coronary angiography, which involves the catheterisation of the patient and the application of iodinated contrast agent. Each year, up to 1 million X-ray based diagnostic procedures are performed, in Europe and the US, but only a fraction of the examined patients (40%) show significant disease¹. Due to the risks of the invasive procedure and the high associated costs, alternative diagnostic approaches are desirable, either as a gatekeeper for the cath-lab or as safe follow-up techniques to control appropriate re-vascularisation procedures.

Magnetic Resonance Imaging (MRI) is a well-established diagnostic imaging modality, which exhibits an excellent soft-tissue contrast and which has found important application in cardiovascular diagnostics². MRI has a

Chapter 7

4-DIMENSIONAL ULTRASONIC IMAGING

Technology Advances and Medical Applications

Mr. R. VISWALINGAM

Department of Biochemistry, Research Development Cell (RDC), PRIST Deemed University, Thanjavur, Tamil Nadu, India.

Abstract: Four-dimensional ultrasound is a relatively newcomer to the diagnostic imaging market. With real-time rendering of moving anatomy, 4-D ultrasonic techniques promise to permit many new applications in the realms of interventional cardiology and radiology, as well as to improve specific existing two-dimensional applications. In this chapter, we will review some of the technical advances that have enabled 4-D ultrasound imaging including hardware and quantification tools, remaining technical challenges, initial clinical applications, and novel areas of medicine to which the technology can be applied.

Keywords: 4-D ultrasound; four-dimensional ultrasound; real-time imaging

1. INTRODUCTION

In this chapter, we will examine the increasingly important role of four-dimensional ultrasound in specific clinical applications and discuss the key technological advances that have enabled the construction of 4-D ultrasound clinical imaging systems. Four-dimensional (4-D) ultrasound is often used as a key marketing phrase and may have different meanings to each reader. In the context of this chapter, we will refer to 4-D ultrasound as any means of providing time-varying volumetric images. This designation will include both real-time and non-real-time techniques for volume acquisition. Often 4-D ultrasound is referred to as 3D + T or real-time 3-D or RT3D to explicitly break out the time-varying component from the spatial dimensions. The reader may also wish to consult other excellent summaries of the state of the art in 4-D ultrasonic medical imaging¹⁻³.



RADIOGRAPHIC INVESTIGATION AND TECHNIQUES IN BIOCHEMISTRY

EDITED BY

DR. N. GNANASEKARAN



978-93-6255-393-5

Radiographic investigation and Techniques in Biochemistry

Copyright © 2023 by Dr. N. Gnanasekaran

All rights reserved. No part of this book may be reproduced or transmitted in any form or by any means without written permission from the author.

ISBN: 978-93-6255-393-5



Publisher: Ponnaiyah Ramajayam Institute of Science and
Technology (PRIST)

TABLE OF CONTENTS

| | | |
|--|---------------------------------------|-----|
| Chapter 1 <i>Nanotechnology Potential Applications and Market Analysis</i> | Dr. A. SHAJAHAN | 1 |
| Chapter 2 <i>Types of Nanomaterials and Corresponding Methods of Synthesis</i> | Dr. S. AMBIGA | 16 |
| Chapter 3 <i>Biocompatibility and Functionalization</i> | Dr. ARJUNPANDIAN | 34 |
| Chapter 4 <i>Nanobiosensors</i> | Dr. C. ANUSHIA | 47 |
| Chapter 5 <i>Targeted Drug Delivery</i> | Dr. T. GUNASEELAN | 68 |
| Chapter 6 <i>Drug Release and Biodegradation</i> | Dr. G. SRITHAR | 92 |
| Chapter 7 <i>The Blood Brain Barrier (BBB)</i> | Dr. A. BAKRUDEEN ALI AHMED | 110 |

Chapter 1

Nanotechnology Potential Applications and Market Analysis

Dr. A. SHAJAHAN

Department of Biotechnology, School of Arts and Sciences, PRIST Deemed University, Thanjavur, Tamil Nadu, India.

INTRODUCTION

Tobacco smoking is the predominant cause of lung cancer, and it has been estimated that about 80% of lung cancers are attributed to smoking (Buiatti et al., 1996). As a complement to smoking cessation in lung cancer prevention, considerable attention has been focused on possible protective factors in the diet. A diet rich in fruits and vegetables has rather consistently been reported to be associated with a reduced risk of lung cancer (Ziegler et al., 1996). Several plausible mechanisms have been suggested, indicating that this reduction may be due to antioxidant micronutrients (Dorgan and Schatzkin, 1991). Thus far considerable attention has been directed to β -carotene, but intervention trials have not confirmed the presence of a protective effect (Albanes et al., 1996; Hennekens et al., 1996; Omenn et al., 1996). Some evidence also suggests that the reduced risk of lung cancer associated with the intake of fruits and vegetables may be due to some other micronutrients, such as vitamin C (Block et al., 1992), flavonoids (Knekt et al., 1997a), and selenium (Clark et al., 1996). The epidemiological evidence is, however, not yet persuasive for any of these, while the question of whether lung cancer can be prevented or slowed down by the antioxidant vitamin E has also been addressed in a number of studies (Knekt, 1994). The aim of this chapter is to review findings from epidemiological studies on the role of vitamin E in cancer prevention and to present some new results from the Finnish Mobile Clinic Health Examination Survey.

REVIEW OF STUDIES

Study Designs and Study Populations

Two intervention trials and 25 observational studies on the association between vitamin E status and lung cancer risk are considered here. In an intervention trial the investigator randomly assigns vitamin E or placebo to the study population and then waits for the

Chapter 2

Types of Nanomaterials and Corresponding Methods of Synthesis

Dr. S. AMBIGA

Department of Biochemistry, School of Arts and Sciences, PRIST Deemed University, Thanjavur, Tamil Nadu, India.

INTRODUCTION

There are currently 3 million tobacco-related deaths in the world each year, and in general smokers can expect to live 7 years less than nonsmokers (World Health Organisation, 1977). This premature mortality is because habitual smoking is associated with an increased risk of developing many diseases, including coronary heart disease, lung cancer, stroke, and emphysema (Health Education Authority, 1992). Paradoxically, analysis across countries reveals little relationship between smoking levels and mortality from diseases such as coronary heart disease and cancer. For example, Japan has one of the lowest incidences of lung cancer in the world despite having one of the highest per capita consumption of cigarettes (Diana, 1993). Similarly, coronary heart disease rates in countries such as Greece and Spain are low despite very high cigarette usage (Fig. 1). This suggests that indigenous factors within countries such as diet may modify the risk of developing smoking-related diseases. Many of the clinical conditions implicated with smoking are also associated with increased indices of free radical-mediated damage to proteins, lipids, and DNA (Duthie and Arthur, 1994), indicating that smoking may exacerbate the initiation and propagation of oxidative stresses, which are potential underlying processes in the pathogenesis of many diseases (Diplock, 1994).

SMOKING AS AN OXIDATIVE STRESS

Smokers inhale large amounts of reactive free radicals arising from the combustion of tobacco. The tar in cigarettes contains more than 10¹⁷ stable long-lived quinone-semiquinone radicals per gram, which are generated by the oxidation of polycyclic aromatic hydrocarbons during the combustion process. These can reduce oxygen to superoxide and hydrogen peroxide and result in the production of the highly reactive hydroxyl radical. The gas phase smoke contains more than 10¹⁰ free radicals per puff of shortlived, reactive carbon- and oxygen-centered peroxy species. These can achieve in the field polycyclic aromatic hydrocarbons.

Chapter 3

Biocompatibility and Functionalization

Dr. Arjunpandian

Department of Biotechnology, School of Arts and Sciences, PRIST Deemed University, Thanjavur, Tamil Nadu, India.

INTRODUCTION

We are at the threshold of the second revolution in our understanding of the role of nutrition in disease and health. The first revolution took place early in this century, with the discovery of the frank nutrient deficiency diseases and their causes. As a result of that research in the nutritional sciences, we essentially eliminated beriberi, pellagra, rickets, and goiter. We did so, incidentally, not by education but by fortification.

Today we are at the threshold of an even greater revolution, and it involves the antioxidant nutrients, including vitamin C, vitamin E, and the carotenoids. Increasingly, research suggests that these nutrients are of great importance in reducing the risk of cancer and heart disease, the two major killers in Western society. However, beyond these diseases, it is increasingly apparent that antioxidants may be important in most of the diseases of aging, including age-related eye diseases such as cataracts, and impaired immune function resulting in increased susceptibility to infection.

Evidence for an important role for antioxidant nutrients comes from the complete spectrum of biomedical research fields, from biochemical research, animal studies, epidemiologic data, and clinical trials. Any one of these alone would be insufficient as a basis for public policy.

LABORATORY AND ANIMAL DATA ON OXIDATION AND ANTIOXIDANTS

Oxidation

Oxidation is the transfer of electrons from one atom to another. It is an essential part of normal metabolism. The process of extracting energy from food involves the transfer of electrons, with release of energy at each step, through a series of electron acceptors until

Chapter 4

Nanobiosensors

Dr. C. ANUSHIA

Department of Biotechnology, School of Arts and Sciences, PRIST Deemed University, Thanjavur, Tamil Nadu, India.

I. INTRODUCTION

25-Hydroxyvitamin D (25OHD)* is the first hydroxylated metabolite of vitamin D (D) and the immediate precursor of the fully active and hormonal form of the vitamin, $1\alpha,25$ -dihydroxyvitamin D [$1,25(\text{OH})_2\text{D}$]. It was discovered by DeLuca and his group, who rapidly identified the liver as the first site of activation of D₃ [1–3]. Over the past 35 years, the enzyme systems involved in the C-25 hydroxylation of D₃, D₂, and several of their analogs have been the object of intense studies by groups in North America, Europe, and Japan. The research has allowed the identification of two intrahepatic organelles, the smooth endoplasmic reticulum (microsomes) and the mitochondrion, as sites possessing fully active but distinct D 25-hydroxylases.

The mitochondrial enzyme has been cloned [4–6] and its identity as a D₃ 25-hydroxylase established with certainty. Moreover, its presence and activity has been positively identified in all species studied including the human [7]. The microsomal enzyme received the attention of early workers in the field. It has been identified clearly in the pig, where the enzyme has been cloned and clearly shown to hydroxylate D₃ and D₂ at C-25 [8]. Lately, a new microsomal D 25-hydroxylase species has also been cloned and its gene transcript shown to be present in mice and humans [9]. The latter is also reported to be active in the C-25 hydroxylation of both D₃ and D₂. In most species, early work has shown that the microsomal D₃ 25-hydroxylase is an enzyme also active in the oxidation of several endogenous and exogenous substances and, based on the enzyme kinetics of the respective microsomal and mitochondrial enzymes, believed by many to be more physiologically relevant than the mitochondrial entity. In this chapter, we review the most relevant research area on the D 25-hydroxylases and address the specificity and regulation of each enzyme in the context of its dynamic functioning, including uptake, ontogeny, sex-related differences,

Chapter 5

Targeted Drug Delivery

Dr. T. GUNASEELAN

Department of Biochemistry, School of Arts and Sciences, PRIST Deemed University,
Thanjavur, Tamil Nadu, India.

I. OCCURRENCE AND CHARACTERISTICS OF 25-HD3 1 α -HYDROXYLASE

A. The Kidney as the Source of Circulating 1 α ,25(OH)₂D₃ It is now well accepted that vitamin D is a precursor of the sterol hormone 1 α ,25-dihydroxyvitamin D₃ [1 α ,25(OH)₂D₃]. The general pathway of production of 1 α ,25(OH)₂D₃ is shown in Fig. 1. It has been appreciated for some time [1,2] that the kidney is the major site of production of circulating 1 α ,25(OH)₂D₃, although as described later and discussed more thoroughly elsewhere in this volume, many other tissues and cell types have been shown to produce 1 α ,25(OH)₂D₃ from 25-hydroxyvitamin D₃ (25OHD₃). Within the kidney, it was established early on by microdissection studies that in the fetal rabbit [3] and in the vitamin D-deficient rat [4] and chick [5], the proximal tubules are the region of the most robust activity of the 1 α -hydroxylase. With the cloning of the cDNA for the cytochrome P450 component of the 1 α -hydroxylase (see Section III) has come the ability to measure its mRNA and protein levels along the nephron. Since these determinations are more sensitive than the measurement of enzyme activity, localization studies can now be carried out under conditions of vitamin D sufficiency and normal mineral status.

Thus in vitamin D-sufficient mice and humans, mRNA and/or protein has been identified by in situ hybridization or immunohistochemical staining in the more distal portions of the nephron along with relatively low expression in the proximal tubules [6,7]. These observations suggest that, while the 1 α -hydroxylase occurs throughout the nephron, its regulation varies such that the effects of vitamin D status and abnormal phosphorus metabolism (see Section IV) occur primarily if not exclusively in the proximal tubules. In situ hybridization studies of cultures of embryonic mouse kidneys confirm the presence of 25OHD₃ 1 α -hydroxylase (CYP1 α) in tubular epithelium, but not collecting ducts or glomeruli [8]. Along with the demonstration that the kidney contained the enzymatic capability to produce 1 α ,25(OH)₂D₃ other work was suggesting that this metabolic step was largely confined to this organ.

Chapter 6

Drug Release and Biodegradation

Dr. G. SRITHAR

Department of Biochemistry, School of Arts and Sciences, PRIST Deemed University, Thanjavur, Tamil Nadu, India.

I. BACKGROUND

A. Enzyme Function and Regulated Expression Vitamin D is a secosteroid whose biological function is dependent upon its metabolic activation and turnover. These metabolite pathways contain specific hydroxylase enzymes that are members of the cytochrome P450 superfamily of mixed-function monooxygenases. Bioactivation of vitamin D involves the sequential actions of 25-hydroxylase and 1-hydroxylase enzymes leading to the synthesis of the hormonally active secosteroid 1,25-dihydroxyvitamin D [1,25(OH)₂D]* (Fig. 1). These two enzymes are discussed in Chapter 4 (vitamin D 25-hydroxylase) and Chapter 5 (25-hydroxyvitamin D 1 α -hydroxylase) and will be mentioned in this chapter only on a comparative basis to 25-hydroxyvitamin D- 24(R)-hydroxylase cytochrome P450c24 (CYP24), the enzyme that directs the side-chain metabolism of 25-hydroxylated vitamin D metabolites, which leads to their terminal physiological inactivation and turnover.

Most cellular actions of vitamin D are mediated through the secosteroid hormone 1,25(OH)₂D and involve the transcription of vitamin D-dependent genes. These regulatory processes involve the coordinated modulation and coupling of rapid signal-transduction pathways with slower acting ligand-dependent transcription factors [1]. In both cases, the secosteroid ligand binds to a ligand-specific receptor. The rapid response receptor is located in the cellular membrane of target tissues and initiates rapid signaling responses through a receptor that has been referred to as the membrane-associated receptor membrane-associated rapid response steroid (MSSRS) receptor complex [2,3]. The hormone receptor for the transcription process involves the nuclear vitamin D receptor (nVDR), which is a ligand-dependent transcription factor that functions as a VDR:1,25(OH)₂D heterodimeric complex with the cis-retinoic acid: RXR complex (i.e., VDR-RXR) to regulate vitamin D-dependent genes associated with development and homeostasis (see Chapters 13–17 for details). Cellular and ambient levels 1,25(OH)₂D are regulated through the hormone's synthesis and degradation. The regulated 1 α -hydroxylase (i.e., P450c1 or CYP27B1) directs the hormone's biosynthesis.

Chapter 7

The Blood Brain Barrier (BBB)

Dr. A. BAKRUDEEN ALI AHMED

Department of Biochemistry, School of Arts and Sciences, PRIST Deemed University, Thanjavur, Tamil Nadu, India.

Too much selenium (Se) in the diet is detrimental to animal health. The most toxic compounds are Se inorganic salts and Se methionine, which are found in water and plants. However, low soil content results in deficiency syndromes. In humans, clinical manifestations of deficiency are Keshan's disease, a severe cardiomyopathy, Kashin-Beck disease, an osteoarthropathy (1), and cretinism, when associated with an iodine deficiency (2). The eradication of Keshan disease by dietary Se supplementation (3, 4) further strengthened the correlation between low soil content and the disease. Interestingly, however, other complicating factors, such as viruses, have been implicated to explain the seasonal recurrence of this disease (5, 6). To this end, the induction of virulence in certain viruses by selenodeficiency, as documented for the human Coxsackievirus B3, which becomes virulent after the infection of Se-deficient mice and maintains its virulence in normal animals (7-9), is one of the most important aspects of recent selenium research. This observation might provide a rationale for the evidence that different diseases are due to the deficiency of the same element and it may also be relevant for cancer research. Furthermore, in vitro experiments suggest a role for Se in atherosclerosis or aging (10), but convincing epidemiological studies of this aspect are still missing.

Historically, knowledge of the beneficial effects of Se has come from livestock. It is well known that, together with vitamin E, Se supplementation prevents liver necrosis, degeneration of skeletal and cardiac muscles, reduced growth rate, and infertility in cattle (1). This last aspect has been clarified in recent years by well-documented nutritional studies. In selenodeficiency, selenium levels decrease in other organs, but not in testis (11), suggesting that this element may have a peculiar function. Furthermore, with the progression of the deficiency, various degrees of degeneration appear in the seminiferous epithelium, first involving only the mitochondria of spermatids and spermatozoa (12), resulting in a complete disappearance of mature germinal cells (13).

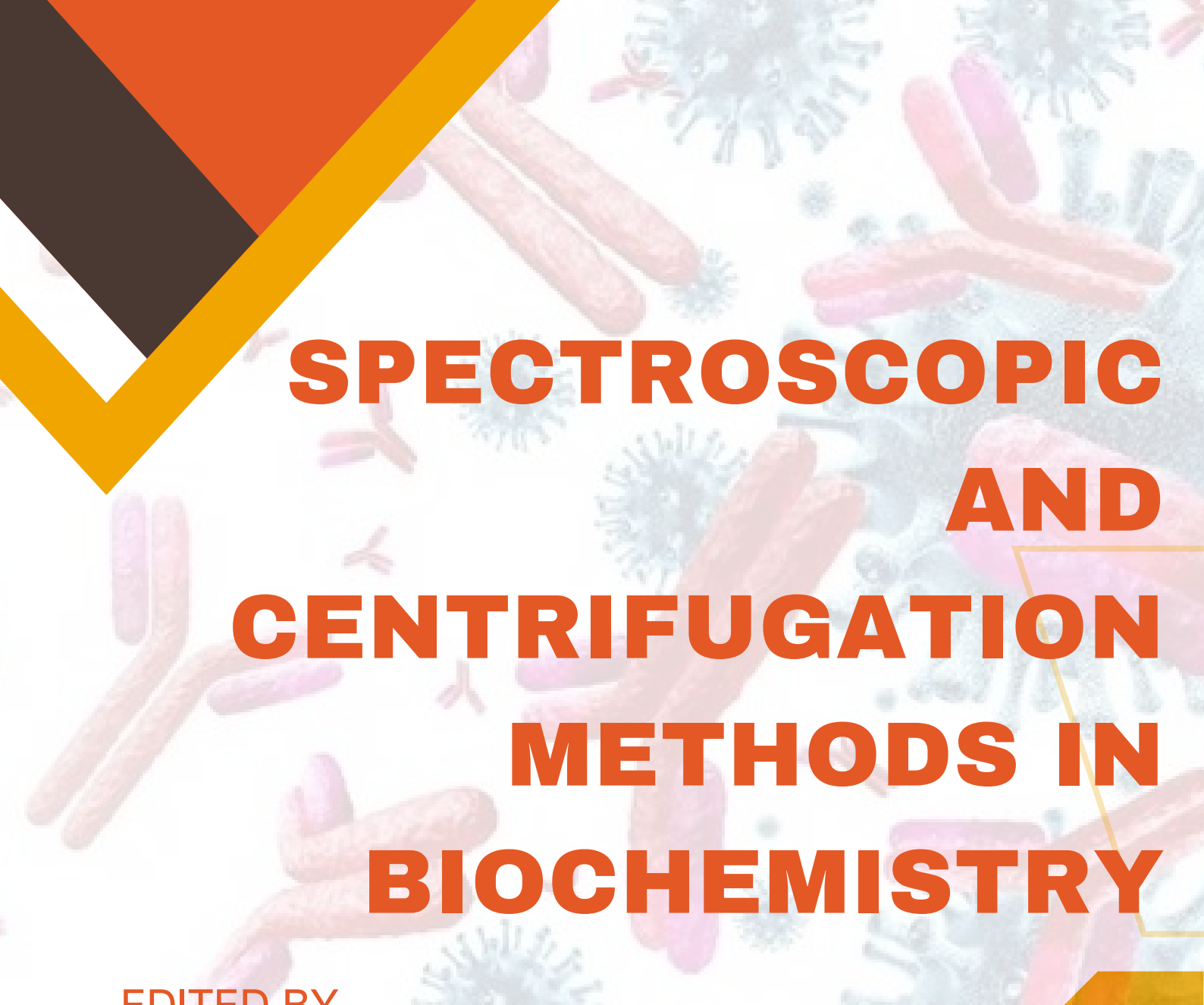

**SPECTROSCOPIC
AND
CENTRIFUGATION
METHODS IN
BIOCHEMISTRY**

EDITED BY

DR. S. SATHISHKUMAR



978-93-6255-493-2

Spectroscopic and Centrifugation Methods in Biochemistry

Copyright © 2021 by Dr. S. Sathishkumar

All rights reserved. No part of this book may be reproduced or transmitted in any form or by any means without written permission from the author.

ISBN: 978-93-6255-493-2



Publisher: Ponnaiyah Ramajayam Institute of Science and
Technology (PRIST)

CONTENTS

| | | |
|---|---|-----------|
| Chapter 1 The Roots of DNA Research | DR. ARJUNPANDIAN | 1 |
| Chapter 2 The Double Helix | DR. A. SHAJAHAN | 14 |
| Chapter 3 DNA In Action | DR. G. VENKATKUMAR | 32 |
| Chapter 4 Foundations of DNA Technology | Dr. A. SOHNA CHANDRA PACKIAVATHI | 45 |
| Chapter 5 Methods of DNA Technology | Dr. BAKRUDEEN ALI AHMED | 52 |
| Chapter 6 Pharmaceutical Products of DNA Technology | Dr. S. AMBIGA | 65 |
| Chapter 7 DNA Analysis and Diagnosis | Dr. M. VIJAY | 78 |



CHAPTER OUTLINE

Looking Ahead

Introduction

Inheritance Factors

Chromosomes and Factors

Genes and DNA

Relating DNA to Heredity

Bacterial Transformations

The Hershey-Chase Experiment

Summary

Review



LOOKING AHEAD

DNA technology has its foundations in genetics, the science of heredity.

It is appropriate, therefore, to open this book by exploring the insights and experiments that led scientists to recognize DNA as the hereditary substance.

When you have completed the chapter, you should be able to:

- recognize how the experiments of Gregor Mendel focused attention on cellular factors as the basis for inheritance.
- understand the circumstances under which Mendel's experiments were verified and how Sutton related Mendel's "factors" to cellular units called chromosomes.
- show how Morgan related eye color in fruit flies to chromosomes.
- appreciate the origin of the term "gene" and describe how the gene concept emerged.
- recount Miescher's work on nuclei and conceptualize how Feulgen and Mirsky contributed to the insight that genes are composed of DNA.
- understand the significance of Griffith's experiments in bacterial transformation and conceptualize how the transforming principle was identified as DNA.
- explain the seminal experiments of Hershey and Chase and describe why their results pointed to DNA as the substance controlling protein and nucleic acid synthesis.
- increase your vocabulary of terms relating to DNA technology.



CHAPTER OUTLINE

Looking Ahead

Introduction

The Structure of DNA

 The Components of DNA

 DNA in Three Dimensions

DNA Replication

Summary

Review



LOOKING AHEAD

Determining the structure of DNA was one of the major scientific achievements of the twentieth century. Knowing DNA's structure gave scientists insight to how heredity works and stimulated the development of molecular biology and DNA technology. Moreover, it helped them understand how DNA replicates during cellular reproduction. On completing this chapter, you should be able to:

- recognize the three elements of DNA and how they combine with one another to form nucleotides.
- describe how sugars and phosphate groups link together to form the "backbone" of the DNA molecule.
- summarize Erwin Chargaff's findings and indicate why they were important in determining DNA's structure.
- understand the contributions of Franklin, Wilkins, Watson, and Crick in determining the structure of DNA.
- explain how DNA replicates by the semiconservative method and summarize the experimental process by which Meselson and Stahl determined this method.
- use your newly acquired vocabulary to speak confidently about DNA structure.

CHAPTER OUTLINE

Looking Ahead

Introduction

Foundation Studies

 The One Gene–One Enzyme Hypothesis

 Proteins and Codes

 The Intermediary

 The Genetic Code

Protein Synthesis

 Transcription

 Translation

 Gene Control

 Gene Complexity

Summary

Review

LOOKING AHEAD

This chapter explores the succession of observations and experiments that led scientists to relate deoxyribonucleic acid (DNA) to protein synthesis. It also describes the mechanisms by which the biochemical information in DNA is converted to biochemical information in protein. On completing this chapter, you should be able to:

- understand how scientists made the connection between chromosomes and biochemical activities taking place in the cell and between gene activity and the chemistry of enzymes.
- follow the reasoning that led scientists to a genetic code in DNA and helped them relate the code to an amino acid sequence in protein.
- recognize the role played by ribonucleic acid (RNA) in translating the genetic message in DNA to an amino acid sequence in protein.
- comprehend the nature of the genetic codes in DNA and understand how various genetic sequences were established.
- conceptualize the processes of transcription and translation in the synthesis of protein as they occur in the cell.
- understand the need for gene control in a cell and summarize some negative and positive mechanisms by which that control comes about.
- explain the various types of regulatory mechanisms that contribute to the complex biochemistry by which a gene is expressed.

CHAPTER OUTLINE

Looking Ahead

Introduction

The Tools of Genetic Engineering

 The Organisms

 Microbial Recombinations

 Restriction Enzymes

 Ligases

 Plasmids

Recombinant DNA Experiments

 The Safety Issue

 The Future

Summary

Review

LOOKING AHEAD

This chapter focuses on the discoveries and developments that laid the foundations for the practical applications of DNA technology. When you have completed this chapter, you should be able to:

- understand the nature of the biochemical tools used in DNA technology and recognize why microorganisms occupy an important place in the experiments of DNA technology.
- discuss the key discoveries and experiments that formed the basis for modern DNA technology.
- identify some of the individuals whose work laid the foundations for DNA technology.
- conceptualize the basic processes used in gene splicing and DNA technology and prepare for the chapters ahead.
- discuss briefly some of the theoretical and practical applications of DNA technology and acquire an overview of the implications of this skill.
- recognize some important terms and concepts used in DNA technology and broaden your vocabulary of this science.

CHAPTER OUTLINE

Looking Ahead

Introduction

The Biochemistry of Gene Expression

Obtaining the Gene

Selecting the Vector

Selecting the Host Cell

Expressing the Gene

Collecting the Gene Product

Gene Libraries

Establishing a Library

Screening the Gene Library

The cDNA Library

Summary

Review

LOOKING AHEAD

The pages of this chapter describe the methods used by DNA technologists to recombine cells with foreign genes and stimulate those cells to produce proteins having practical use. On completing the chapter, you should be able to:

- understand how genes are isolated from cells or synthesized in the laboratory for use in DNA technology.
- list some criteria for selecting vectors to carry foreign genes and host cells to produce the protein encoded by those genes.
- conceptualize the biochemistry involved in gene expression, understand the problems that can arise in the process, and learn how DNA technologists resolve those problems.
- explain the concept of the gene library, describe the process for establishing two types of gene libraries, and discuss how genes are recovered from the library.

Pharmaceutical Products of DNA Technology 6



CHAPTER OUTLINE

Looking Ahead

Introduction

Human Protein Replacements

Insulin

Human Growth Hormone

Factor VIII

Human Therapies

Tissue Plasminogen Activator

Interferon

Antisense Molecules

Other Innovative Pharmaceuticals

Vaccines

Hepatitis B

Acquired Immune Deficiency Syndrome

Other Traditional Vaccines

DNA Vaccines

Summary

Review



LOOKING AHEAD

Some of the most useful applications of DNA technology occur in the pharmaceutical industry. This chapter explores the range of pharmaceutical products manufactured through DNA technology. On completing the chapter, you should be able to:

- understand how deficiencies of proteins, such as insulin, human growth hormone, and Factor VIII, contribute to ill health and how DNA technology can be used to produce these proteins.
- appreciate some of the biochemical problems encountered in manufacturing pharmaceutical products by DNA technology and recognize how biochemists circumvent these problems.
- discuss the synthesis and innovative uses of therapeutic drugs such as tissue plasminogen activator, interferon, and antisense molecules and summarize how they can be used to relieve disease.
- understand the basis of vaccine activity in the body and conceptualize the role of DNA technology in the production of vaccines.

CHAPTER OUTLINE

Looking Ahead

Introduction

Methods of DNA Analysis

DNA Probes

The Polymerase Chain Reaction

Signal Amplification

The DNA Chip

RFLP Analysis

Diagnosing Infectious Disease

Acquired Immune Deficiency Syndrome

Tuberculosis

Lyme Disease

Human Papilloma Virus and Other Diseases

Identifying Genetic Disease

Cystic Fibrosis

Duchenne's Muscular Dystrophy

Huntington's Disease

Fragile X Syndrome

Triple Repeat Disease

Retinoblastoma

Alzheimer's Disease

Amyotrophic Lateral Sclerosis

Diabetes

Cancer

Obesity

Hearing and Vision Loss

Other Human Diseases

Gene Banking

Environmental Monitoring

Summary

Review

LOOKING AHEAD

One of the more remarkable uses of DNA technology is in the diagnostic laboratory to analyze samples and detect whether certain genes and DNA segments are present. How this technology is performed and how it is applied are the major thrusts of this chapter. On completing these pages, you should be able to:

- understand the nature of a DNA probe and appreciate how it identifies a segment of target DNA.



DIFFERENTIAL EQUATIONS

EDITED BY
DR.R.ABIRAMI



978-93-6255-667-7

Differential Equations

Copyright © 2023 by Dr.R.Abirami

First Edition,2023

All rights reserved. No part of this book may be reproduced or transmitted in any form or by any means without written permission from the author.

ISBN: 978-93-6255-667-7

Publisher: Ponnaiyah Ramajayam Institute of Science and Technology (**PRIST**)

TABLE OF CONTENTS

| Book elements | Page Numbers |
|--|---------------------|
| ----- Chapter-I ORDINARY DIFFERENTIAL EQUATIONS Dr.R.Abirami | 01-05 |
| ----- Chapter-II FIRST-ORDER ODES (NOT HIGHER DEGREE) Dr.R.Abirami | 06-10 |
| ----- Chapter-III SIMULTANEOUS LINEAR DIFFERENTIAL EQUATIONS Dr.R.Abirami | 11-20 |
| ----- Chapter-IV PARTIAL DIFFERENTIAL EQUATION Dr.R.Abirami | 21-27 |
| ----- Chapter-V SPECIAL METHODS AND APPLICATIONS Dr.R.Abirami | 28-30 |
| ----- | |

ORDINARY DIFFERENTIAL EQUATIONS

Dr.R.Abirami

Asst. Professor in Mathematics

Ponmaiya Ramajayam Institute of Science and Technology (PRIST)

Vallam, Thanjavur, Tamilnadu, South India

Ordinary Differential Equations (ODEs) are a fundamental concept in mathematics and are used to model various phenomena in fields like physics, engineering, economics, and more.

What are ODEs?

ODEs are equations that involve an unknown function and its derivatives, and are used to describe how the function changes over time or space. They are called "ordinary" because they involve only one independent variable, unlike partial differential equations (PDEs), which involve multiple independent variables.

Types of ODEs:

1. **First-order ODEs:** involve only the first derivative of the unknown function.
2. **Higher-order ODEs:** involve higher derivatives of the unknown function.
3. **Linear ODEs:** can be written in the form of a linear combination of the unknown function and its derivatives.
4. **Nonlinear ODEs:** cannot be written in this form.

Solving ODEs:

ODEs can be solved using various techniques, including:

1. **Separation of variables**
2. **Integrating factor**
3. **Undetermined coefficients**
4. **Variation of parameters**
5. **Numerical methods** (e.g., Euler's method, Runge-Kutta method)

Applications of ODEs:

1. **Population dynamics**
2. **Mechanical systems** (e.g., pendulum, mass-spring system)
3. **Electrical circuits**
4. **Chemical reactions**
5. **Epidemiology** (modeling the spread of diseases)

Separation of variables is a technique used to solve first-order ordinary differential equations (ODEs) of the form:

$$dy/dx = f(x)g(y)$$

Steps:

1. **Separate the variables:** Rearrange the equation to have all the y terms on one side and all the x terms on the other side.

$$dy/g(y) = f(x)dx$$

2. **Integrate both sides:** Integrate the left side with respect to y and the right side with respect to x.

$$\int dy/g(y) = \int f(x)dx$$

3. **Solve for y:** After integrating, solve for y to get the general solution.

Example:

Solve the ODE:

$$dy/dx = 2x/y$$

Solution:

1. Separate the variables:

$$y dy = 2x dx$$

2. Integrate both sides:

$$\int y dy = \int 2x dx$$

3. Solve for y:

$$(y^2)/2 = x^2 + C$$

where C is the constant of integration.

Note: This technique only works if the ODE can be written in the form $dy/dx = f(x)g(y)$. If the ODE is not in this form, other techniques must be used.

Integrating Factor

An integrating factor is a technique used to solve first-order linear ordinary differential equations (ODEs) of the form:

$$dy/dx + P(x)y = Q(x)$$

Steps:

1. **Find the integrating factor:** $\mu(x) = e^{\int P(x)dx}$
2. **Multiply the ODE by $\mu(x)$:** $\mu(x)dy/dx + \mu(x)P(x)y = \mu(x)Q(x)$
3. **Recognize the left side as the derivative of a product:** $d(\mu(x)y)/dx = \mu(x)Q(x)$
4. **Integrate both sides:** $\int d(\mu(x)y) = \int \mu(x)Q(x)dx$
5. **Solve for y:** $\mu(x)y = \int \mu(x)Q(x)dx + C$, where C is the constant of integration

Example:

Solve the ODE:

$$dy/dx + 2xy = e^{-x^2}$$

Solution:

1. Find the integrating factor: $\mu(x) = e^{\int 2x dx} = e^{x^2}$
2. Multiply the ODE by $\mu(x)$: $e^{x^2}dy/dx + 2xe^{x^2}y = e^{-x^2}e^{x^2}$
3. Recognize the left side as the derivative of a product: $d(e^{x^2}y)/dx = 1$
4. Integrate both sides: $\int d(e^{x^2}y) = \int 1 dx$
5. Solve for y: $e^{x^2}y = x + C$

Note: This technique only works for first-order linear ODEs. If the ODE is not in this form, other techniques must be used.

Undetermined Coefficients

The method of undetermined coefficients is a technique used to solve nonhomogeneous linear ordinary differential equations (ODEs) with constant coefficients:

$$a_n y^{(n)} + a_{(n-1)} y^{(n-1)} + \dots + a_1 y' + a_0 y = f(x)$$

where $f(x)$ is a polynomial, exponential, sine, cosine, or a combination of these.

Steps:

1. **Find the complementary solution (y_c):** Solve the corresponding homogeneous equation ($f(x) = 0$) using techniques like separation of variables or integrating factor.
2. **Assume a particular solution (y_p):** Based on the form of $f(x)$, assume a particular solution with undetermined coefficients.

3. **Substitute y_p into the ODE:** Substitute y_p into the original ODE and equate coefficients.
4. **Solve for the undetermined coefficients:** Solve the resulting system of equations for the undetermined coefficients.
5. **Write the general solution:** Combine the complementary solution and particular solution: $y = y_c + y_p$

Example:

Solve the ODE:

$$y'' + 4y = 2x + 3\sin(2x)$$

Solution:

1. Find the complementary solution: $y_c = c_1\cos(2x) + c_2\sin(2x)$
2. Assume a particular solution: $y_p = Ax + B + C\sin(2x) + D\cos(2x)$
3. Substitute y_p into the ODE and equate coefficients.
4. Solve for the undetermined coefficients: $A = 1/2, B = 0, C = -3/2, D = 0$
5. Write the general solution: $y = c_1\cos(2x) + c_2\sin(2x) + (1/2)x - (3/2)\sin(2x)$

Note: This technique only works for nonhomogeneous linear ODEs with constant coefficients and specific forms of $f(x)$. If the ODE does not fit this criteria, other techniques must be used.

Variation of Parameters

Variation of parameters is a technique used to solve nonhomogeneous linear ordinary differential equations (ODEs) of the form:

$$y'' + P(x)y' + Q(x)y = R(x)$$

Steps:

1. **Find the complementary solution (y_c):** Solve the corresponding homogeneous equation ($R(x) = 0$) using techniques like separation of variables or integrating factor.
2. **Assume a particular solution (y_p):** Let $y_p = u_1(x)y_1(x) + u_2(x)y_2(x)$, where y_1 and y_2 are linearly independent solutions of the homogeneous equation.
3. **Substitute y_p into the ODE:** Substitute y_p into the original ODE and equate coefficients.
4. **Solve for u_1 and u_2 :** Solve the resulting system of equations for u_1 and u_2 .
5. **Write the general solution:** Combine the complementary solution and particular solution: $y = y_c + y_p$

Example:

Solve the ODE:

$$y'' + y = \sec^2(x)$$

Solution:

1. Find the complementary solution: $y_c = c_1 \cos(x) + c_2 \sin(x)$
2. Assume a particular solution: $y_p = u_1(x) \cos(x) + u_2(x) \sin(x)$
3. Substitute y_p into the ODE and equate coefficients.
4. Solve for u_1 and u_2 : $u_1(x) = -\tan(x)$, $u_2(x) = x$
5. Write the general solution: $y = c_1 \cos(x) + c_2 \sin(x) - \tan(x) \cos(x) + x \sin(x)$

FIRST-ORDER ODES (NOT HIGHER DEGREE)**Dr.R.Abirami**

*Asst. Professor in Mathematics
Ponnaiyah Ramajayam Institute of Science and Technology (PRIST)
Vallam, Thanjavur, Tamilnadu, South India*

First-order ODEs that are not higher degree can be written in the form:

$$dy/dx = f(x,y)$$

where $f(x,y)$ is a function of x and y .

Types:

1. **Separable equations:** $dy/dx = g(x)h(y)$
2. **Linear equations:** $dy/dx + P(x)y = Q(x)$
3. **Exact equations:** $dy/dx = M(x,y) + N(x,y)y$
4. **Bernoulli's equations:** $dy/dx + P(x)y = Q(x)y^n$

Methods:

1. **Separation of variables**
2. **Integrating factor**
3. **Exact equations method**
4. **Substitution method** (for Bernoulli's equations)

Example:

Solve the ODE: $dy/dx = (2x - 3y) / (x + 1)$

Solution:

This is a linear equation. Using the integrating factor method, we get:

$$\mu(x) = e^{\int (3/(x+1))dx} = e^{(3\ln(x+1))} = (x+1)^3$$

Multiplying both sides by $\mu(x)$, we get:

$$d((x+1)^3y)/dx = 2(x+1)^2$$

Integrating both sides, we get:

$$(x+1)^3 y = \int 2(x+1)^2 dx = (2/3)(x+1)^3 + C$$

$$y = (2/3) + C/(x+1)^3$$

Note: First-order ODEs that are not higher degree can often be solved using these methods. However, some ODEs may require more advanced techniques or numerical methods.

Separable Equations

A separable equation is a first-order ordinary differential equation (ODE) that can be written in the form:

$$dy/dx = g(x)h(y)$$

where $g(x)$ is a function of x alone and $h(y)$ is a function of y alone.

Steps to Solve:

1. **Separate the variables:** Rearrange the equation to have all the y terms on one side and all the x terms on the other side.

$$dy/h(y) = g(x)dx$$

2. **Integrate both sides:** Integrate the left side with respect to y and the right side with respect to x .

$$\int dy/h(y) = \int g(x)dx$$

3. **Solve for y :** After integrating, solve for y to get the general solution.

Example:

Solve the ODE: $dy/dx = (2x)/(3y^2)$

Solution:

1. Separate the variables: $dy/(3y^2) = 2x dx$
2. Integrate both sides: $\int dy/(3y^2) = \int 2x dx$
3. Solve for y : $-1/(3y) = x^2 + C$

$$y = -1/(3(x^2 + C))$$

Note: Separable equations are a type of first-order ODE that can be solved using this method. The key is to separate the variables and integrate both sides.

Linear Equations

A linear equation is a first-order ordinary differential equation (ODE) that can be written in the form:

$$dy/dx + P(x)y = Q(x)$$

where $P(x)$ and $Q(x)$ are functions of x alone.

Steps to Solve:

1. **Find the integrating factor:** $\mu(x) = e^{\int P(x)dx}$
2. **Multiply both sides by $\mu(x)$:** $\mu(x)dy/dx + \mu(x)P(x)y = \mu(x)Q(x)$
3. **Recognize the left side as the derivative of a product:** $d(\mu(x)y)/dx = \mu(x)Q(x)$
4. **Integrate both sides:** $\int d(\mu(x)y) = \int \mu(x)Q(x)dx$
5. **Solve for y :** $\mu(x)y = \int \mu(x)Q(x)dx + C$

Example:

Solve the ODE: $dy/dx + 2xy = 3x$

Solution:

1. Find the integrating factor: $\mu(x) = e^{\int 2x dx} = e^{x^2}$
2. Multiply both sides by $\mu(x)$: $e^{x^2}dy/dx + 2xe^{x^2}y = 3xe^{x^2}$
3. Recognize the left side as the derivative of a product: $d(e^{x^2}y)/dx = 3xe^{x^2}$
4. Integrate both sides: $\int d(e^{x^2}y) = \int 3xe^{x^2}dx$
5. Solve for y : $e^{x^2}y = \int 3xe^{x^2}dx + C$

$$y = e^{-x^2} \int 3xe^{x^2}dx + Ce^{-x^2}$$

Note: Linear equations are a type of first-order ODE that can be solved using this method. The key is to find the integrating factor and multiply both sides by it.

Exact Equations

An exact equation is a first-order ordinary differential equation (ODE) that can be written in the form:

$$dy/dx = M(x,y) + N(x,y)y$$

where $M(x,y)$ and $N(x,y)$ are functions of x and y .

Condition for Exactness:

For the equation to be exact, the following condition must be satisfied:

$$\partial M/\partial y = \partial(Ny)/\partial x$$

Steps to Solve:

1. **Check for exactness:** Verify that the condition for exactness is satisfied.
2. **Find the function $F(x,y)$:** Find a function $F(x,y)$ such that:

$$\frac{\partial F}{\partial x} = M(x,y)$$

$$\frac{\partial F}{\partial y} = N(x,y)$$

3. **Write the general solution:** The general solution is given by:

$$F(x,y) = C$$

where C is an arbitrary constant.

Example:

Solve the ODE: $dy/dx = 2xy + x^2$

Solution:

1. Check for exactness: $\partial M/\partial y = 2x = \partial(Ny)/\partial x$
2. Find the function $F(x,y)$: $\partial F/\partial x = x^2$, $\partial F/\partial y = 2xy$

$$F(x,y) = x^2y + g(y)$$

3. Write the general solution: $x^2y + g(y) = C$

Note: Exact equations are a type of first-order ODE that can be solved using this method. The key is to find the function $F(x,y)$ that satisfies the exactness condition.

Bernoulli's Equations

A Bernoulli's equation is a first-order ordinary differential equation (ODE) that can be written in the form:

$$dy/dx + P(x)y = Q(x)y^n$$

where $P(x)$ and $Q(x)$ are functions of x , and n is a real number.

Steps to Solve:

1. **Divide by y^n :** Divide both sides by y^n to get:

$$y^{(-n)}dy/dx + P(x)y^{(1-n)} = Q(x)$$

2. **Substitute:** Substitute $u = y^{(1-n)}$ to get:

$$u' + P(x)u = Q(x)$$

3. **Solve the linear equation:** Solve the linear equation using the integrating factor method.
4. **Back-substitute:** Back-substitute $u = y^{(1-n)}$ to get the general solution.

Example:

Solve the ODE: $dy/dx + 2y = 3y^2$

Solution:

1. Divide by y^2 : $y^{(-2)}dy/dx + 2y^{(-1)} = 3$
2. Substitute: $u = y^{(-1)}$, $u' + 2u = 3$

3. Solve the linear equation: $u = 3/2 + Ce^{-2x}$

4. Back-substitute: $y^{-1} = 3/2 + Ce^{-2x}$

$$y = 2/(3 + 2Ce^{-2x})$$

Note: Bernoulli's equations are a type of first-order ODE that can be solved using this method. The key is to divide by y^n and substitute $u = y^{1-n}$ to transform the equation into a linear equation.

SIMULTANEOUS LINEAR DIFFERENTIAL EQUATIONS

Dr.R.Abirami

Asst. Professor in Mathematics

Ponnaiyah Ramajayam Institute of Science and Technology (PRIST)

Vallam, Thanjavur, Tamilnadu, South India

Simultaneous Linear Differential Equations

Simultaneous linear differential equations are a system of two or more linear differential equations that involve two or more dependent variables.

General Form:

The general form of simultaneous linear differential equations is:

$$\frac{dx}{dt} = ax + by + f(t)$$

$$\frac{dy}{dt} = cx + dy + g(t)$$

where x and y are the dependent variables, t is the independent variable, and a , b , c , and d are constants.

Steps to Solve:

1. **Write the equations in matrix form:** Write the equations in matrix form as:

$$X' = AX + F$$

where $X = [x, y]'$, $A = [[a, b], [c, d]]$, and $F = [f(t), g(t)]'$.

2. **Find the eigenvalues and eigenvectors of A:** Find the eigenvalues (λ) and eigenvectors (V) of the matrix A .
3. **Diagonalize the matrix A:** Diagonalize the matrix A using the eigenvalues and eigenvectors.
4. **Solve the diagonalized system:** Solve the diagonalized system of equations.
5. **Transform back to the original variables:** Transform the solution back to the original variables x and y .

Example:

Solve the simultaneous linear differential equations:

$$\begin{aligned} \frac{dx}{dt} &= 2x + 3y \\ \frac{dy}{dt} &= 4x - 2y \end{aligned}$$

Solution:

1. Write the equations in matrix form:

$$X' = \begin{bmatrix} 2 & 3 \\ 4 & -2 \end{bmatrix} X$$

2. Find the eigenvalues and eigenvectors:

$$\begin{aligned} \lambda &= 5, -1 \\ V &= \begin{bmatrix} 1 & 1 \\ 1 & -1 \end{bmatrix} \end{aligned}$$

3. Diagonalize the matrix A:

$$D = \begin{bmatrix} 5 & 0 \\ 0 & -1 \end{bmatrix}$$

4. Solve the diagonalized system:

$$X = e^{5t} \begin{bmatrix} C1 \\ 0 \end{bmatrix} + e^{-t} \begin{bmatrix} 0 \\ C2 \end{bmatrix}$$

5. Transform back to the original variables:

$$\begin{aligned} x &= C1e^{5t} + C2e^{-t} \\ y &= C1e^{5t} - C2e^{-t} \end{aligned}$$

Note: Simultaneous linear differential equations can be solved using this method. The key is to diagonalize the matrix A and solve the diagonalized system.

Here are some additional concepts related to Simultaneous Linear Differential Equations:

1. Homogeneous and Non-Homogeneous Systems

- Homogeneous systems: $F(t) = 0$, solutions are of the form $X = e^{\lambda t}V$
- Non-homogeneous systems: $F(t) \neq 0$, solutions are of the form $X = e^{\lambda t}V + X_p$

2. Linear Independence

- Solutions X_1 and X_2 are linearly independent if their Wronskian is non-zero

3. General Solution

- General solution is a linear combination of linearly independent solutions

4. Initial Conditions

- Initial conditions are used to determine the constants in the general solution

5. Matrix Exponential

- Matrix exponential is used to solve systems of the form $X' = AX$

6. Jordan Canonical Form

- Jordan canonical form is used to diagonalize matrices with repeated eigenvalues

7. Undetermined Coefficients

- Undetermined coefficients are used to find the particular solution of a non-homogeneous system

8. Variation of Parameters

- Variation of parameters is used to find the particular solution of a non-homogeneous system

9. Systems with Repeated Eigenvalues

- Systems with repeated eigenvalues require special handling

10. Numerical Methods

- Numerical methods such as Euler's method and Runge-Kutta method can be used to solve systems of linear differential equations.

Homogeneous and Non-Homogeneous Systems

In the context of Simultaneous Linear Differential Equations, systems can be classified into two categories:

1. Homogeneous Systems

A homogeneous system has the form:

$$X' = AX$$

where X is the vector of dependent variables, A is the coefficient matrix, and X' is the derivative of X .

Characteristics:

- Right-hand side is zero ($F(t) = 0$)
- Solutions are of the form $X = e^{(\lambda t)}V$, where λ is an eigenvalue and V is an eigenvector
- Solutions are linearly independent if their Wronskian is non-zero

2. Non-Homogeneous Systems

A non-homogeneous system has the form:

$$X' = AX + F(t)$$

where $F(t)$ is a non-zero vector of functions.

Characteristics:

- Right-hand side is non-zero ($F(t) \neq 0$)
- Solutions are of the form $X = e^{(\lambda t)}V + X_p$, where X_p is a particular solution

- Particular solutions can be found using methods like undetermined coefficients or variation of parameters

Key differences:

- Homogeneous systems have only the complementary solution ($X_c = e^{(\lambda t)}V$), while non-homogeneous systems have both complementary and particular solutions ($X = X_c + X_p$)
- Homogeneous systems have zero right-hand side, while non-homogeneous systems have a non-zero right-hand side

Understanding the differences between homogeneous and non-homogeneous systems is crucial for solving Simultaneous Linear Differential Equations. Do you have any specific questions or need further clarification?

Linear Independence

Linear independence is a fundamental concept in linear algebra and differential equations. In the context of Simultaneous Linear Differential Equations, linear independence refers to the solutions of a homogeneous system.

Definition:

A set of solutions $\{X_1, X_2, \dots, X_n\}$ is said to be linearly independent if the only constants c_1, c_2, \dots, c_n that satisfy the equation:

$$c_1X_1 + c_2X_2 + \dots + c_nX_n = 0$$

are $c_1 = c_2 = \dots = c_n = 0$.

Wronskian:

The Wronskian is a determinant used to test for linear independence. For a set of solutions $\{X_1, X_2, \dots, X_n\}$, the Wronskian is defined as:

| |
|---|
| W(X1, X2, ..., Xn) = |
| |
| $X_1^{(n-1)} X_2^{(n-1)} \dots X_n^{(n-1)}$ |

If the Wronskian is non-zero, the solutions are linearly independent.

Importance:

Linear independence is crucial because:

- Linearly independent solutions form a basis for the solution space

- The general solution of a homogeneous system can be written as a linear combination of linearly independent solutions

Example:

Consider the homogeneous system:

$$X' = \begin{bmatrix} 2 & 1 \\ 1 & 1 \end{bmatrix} X$$

Two solutions are $X_1 = [e^{2t}, e^{2t}]$ and $X_2 = [e^t, -e^t]$. The Wronskian is:

| | |
|-----------------|--------------|
| $W(X_1, X_2) =$ | $e^{2t} e^t$ |
|-----------------|--------------|

Therefore, X_1 and X_2 are linearly independent.

General Solution

The general solution of a homogeneous system of linear differential equations is a linear combination of linearly independent solutions.

Form:

The general solution has the form:

$$X(t) = c_1 X_1(t) + c_2 X_2(t) + \dots + c_n X_n(t)$$

where:

- X_1, X_2, \dots, X_n are linearly independent solutions
- c_1, c_2, \dots, c_n are arbitrary constants

Properties:

- The general solution satisfies the differential equation
- The general solution is a linear combination of linearly independent solutions
- The general solution contains all possible solutions of the differential equation

Example:

Consider the homogeneous system:

$$X' = \begin{bmatrix} 2 & 1 \\ 1 & 1 \end{bmatrix} X$$

Two linearly independent solutions are $X_1 = [e^{2t}, e^{2t}]$ and $X_2 = [e^t, -e^t]$. The general solution is:

$$X(t) = c_1 [e^{2t}, e^{2t}] + c_2 [e^t, -e^t]$$

Initial Conditions:

To find a particular solution, we need to apply initial conditions. The initial conditions are used to determine the values of the arbitrary constants c_1, c_2, \dots, c_n .

Example:

Given the initial conditions $X(0) = [1, 0]$, we can find the values of c_1 and c_2 :

$$c_1[e^{2t}, e^{2t}] + c_2[e^t, -e^t] = [1, 0]$$

Solving for c_1 and c_2 , we get:

$$c_1 = 1/3, c_2 = 2/3$$

The particular solution is:

$$X(t) = (1/3)[e^{2t}, e^{2t}] + (2/3)[e^t, -e^t]$$

Initial Conditions

Initial conditions are used to determine the specific solution of a differential equation. They are the values of the dependent variables at a specific point, usually at the starting point of the problem.

Types of Initial Conditions:

1. **Initial Value Problem (IVP):** Specified values of the dependent variables at $t = t_0$.

$$X(t_0) = X_0$$

2. **Boundary Conditions:** Specified values of the dependent variables at specific points in space or time.

$$X(a) = A, X(b) = B$$

Importance:

Initial conditions are crucial because:

1. **Unique Solution:** Initial conditions ensure a unique solution to the differential equation.
2. **Physical Significance:** Initial conditions provide physical significance to the problem, relating the solution to real-world scenarios.

Example:

Consider the differential equation:

$$dy/dt = 2y$$

With initial condition:

$$y(0) = 1$$

The solution is:

$$y(t) = e^{2t}$$

Without the initial condition, the solution would be:

$$y(t) = Ce^{2t}$$

where C is an arbitrary constant.

Matrix Exponential

The matrix exponential is a fundamental concept in linear algebra and differential equations. It is used to solve systems of linear differential equations.

Definition:

The matrix exponential of a square matrix A is defined as:

$$e^{(At)} = I + At + \frac{(At)^2}{2!} + \frac{(At)^3}{3!} + \dots$$

where I is the identity matrix.

Properties:

1. **Invertible:** $e^{(At)}$ is invertible for all t .
2. **Differentiable:** $e^{(At)}$ is differentiable for all t .
3. **Satisfies Differential Equation:** $e^{(At)}$ satisfies the differential equation $dX/dt = AX$.

Solving Systems of Linear Differential Equations:

The matrix exponential is used to solve systems of linear differential equations of the form:

$$dX/dt = AX$$

The solution is given by:

$$X(t) = e^{(At)}X(0)$$

where $X(0)$ is the initial condition.

Example:

Consider the system:

$$dX/dt = \begin{bmatrix} 2 & 1 \\ 1 & 1 \end{bmatrix} X$$

The matrix exponential is:

$$e^{(At)} = e^{2t} \begin{bmatrix} 1 & t \\ t & 1 \end{bmatrix}$$

The solution is:

$$X(t) = e^{2t} \begin{bmatrix} 1 & t \\ t & 1 \end{bmatrix} X(0)$$

Jordan Canonical Form

The Jordan canonical form is a diagonalizable matrix that is used to solve systems of linear differential equations. It is a powerful tool for analyzing linear systems.

Definition:

A matrix A is in Jordan canonical form if it is block diagonal, with each block being a Jordan block:

$$A = \begin{bmatrix} J_1 & 0 & \dots & 0 \\ 0 & J_2 & \dots & 0 \\ \dots & \dots & \dots & \dots \\ 0 & 0 & \dots & J_n \end{bmatrix}$$

where each Jordan block J_k has the form:

$$J_k = \begin{bmatrix} \lambda_k & 1 & 0 & \dots & 0 \\ 0 & \lambda_k & 1 & \dots & 0 \\ \dots & \dots & \dots & \dots & \dots \\ 0 & 0 & 0 & \dots & \lambda_k \end{bmatrix}$$

with λ_k being the eigenvalue.

Properties:

1. **Diagonalizable:** Jordan canonical form is diagonalizable.
2. **Block Diagonal:** Jordan canonical form is block diagonal.
3. **Eigenvalues:** Eigenvalues are on the diagonal of each Jordan block.
4. **Solves Differential Equations:** Jordan canonical form solves systems of linear differential equations.

Solving Systems of Linear Differential Equations:

The Jordan canonical form is used to solve systems of linear differential equations of the form:

$$dX/dt = AX$$

The solution is given by:

$$X(t) = e^{(Jt)}X(0)$$

where $X(0)$ is the initial condition.

Example:

Consider the system:

$$dX/dt = \begin{bmatrix} 2 & 1 \\ 0 & 2 \end{bmatrix} X$$

The Jordan canonical form is:

$$J = \begin{bmatrix} 2 & 1 \\ 0 & 2 \end{bmatrix}$$

The solution is:

$$X(t) = e^{(2t)} \begin{bmatrix} 1 & t \\ 0 & 1 \end{bmatrix} X(0)$$

Undetermined Coefficients

Undetermined coefficients is a method used to find the particular solution of a non-homogeneous linear differential equation.

Steps:

1. **Assume a particular solution:** Assume a particular solution of the form $Y_p = A \cdot f(x)$, where A is a constant and $f(x)$ is a function that matches the form of the non-homogeneous term.
2. **Substitute into the differential equation:** Substitute Y_p into the differential equation and equate coefficients.
3. **Solve for the constants:** Solve for the constants A .
4. **Find the particular solution:** Find the particular solution Y_p .

Example:

Consider the differential equation:

$$y'' + 4y = 2x$$

Assume a particular solution $Y_p = Ax + B$.

Substitute into the differential equation:

$$(Ax + B)'' + 4(Ax + B) = 2x$$

Equate coefficients:

$$A + 4Ax + 4B = 2x$$

Solve for A and B :

$$A = 1/2, B = 0$$

Find the particular solution:

$$Y_p = (1/2)x$$

Note: Undetermined coefficients is a useful method when the non-homogeneous term is a polynomial, exponential, or trigonometric function.

Variation of Parameters

Variation of parameters is a method used to find the particular solution of a non-homogeneous linear differential equation.

Steps:

1. **Find the complementary solution:** Find the complementary solution Y_c of the corresponding homogeneous equation.

2. **Assume a particular solution:** Assume a particular solution Y_p of the form $Y_p = uY_1 + vY_2$, where Y_1 and Y_2 are linearly independent solutions of the complementary equation.

3. **Determine the parameters:** Determine the parameters u and v by solving the system of equations:

$$u'Y_1 + v'Y_2 = f(x)$$

where $f(x)$ is the non-homogeneous term.

4. **Find the particular solution:** Find the particular solution Y_p .

Example:

Consider the differential equation:

$$y'' + 4y = 2x$$

Find the complementary solution $Y_c = c_1\cos(2x) + c_2\sin(2x)$.

Assume a particular solution $Y_p = u(x)\cos(2x) + v(x)\sin(2x)$.

Determine the parameters u and v :

$$u'\cos(2x) + v'\sin(2x) - u'2\sin(2x) + v'2\cos(2x) = 2x$$

Solve for u and v :

$$u(x) = -x/2, v(x) = x/4$$

Find the particular solution:

$$Y_p = (-x/2)\cos(2x) + (x/4)\sin(2x)$$

Note: Variation of parameters is a powerful method that can be used for any type of non-homogeneous term.

PARTIAL DIFFERENTIAL EQUATION

Dr.R.Abirami

*Asst. Professor in Mathematics
Ponnaiyah Ramajayam Institute of Science and Technology (PRIST)
Vallam, Thanjavur, Tamilnadu, South India*

- A **Partial Differential Equation (PDE)** is a type of mathematical equation that involves unknown multivariable functions and their partial derivatives. PDEs are used to formulate problems involving functions of several variables and are either solved by hand in simple cases or by numerical methods in complex scenarios.
- **Basic Structure**
- A PDE has the general form:

$$F \left(x_1, x_2, \dots, x_n, u, \frac{\partial u}{\partial x_1}, \dots, \frac{\partial u}{\partial x_n}, \frac{\partial^2 u}{\partial x_1^2}, \dots \right) = 0$$

where:

- $u = u(x_1, x_2, \dots, x_n)$ is the unknown function.
- $\frac{\partial u}{\partial x_i}$ represents the first-order partial derivatives.
- $\frac{\partial^2 u}{\partial x_i^2}$ represents the second-order partial derivatives.
- F is a function that relates these variables and derivatives.

Types of PDEs

PDEs are often classified based on their order, linearity, and other features.

1. Order:

- **First-order PDEs:** Involve only first derivatives.

$$\frac{\partial u}{\partial x} + \frac{\partial u}{\partial y} = 0$$

- **Second-order PDEs:** Involve second derivatives.

$$\frac{\partial^2 u}{\partial x^2} + \frac{\partial^2 u}{\partial y^2} = 0$$

2. Linearity:

- **Linear PDEs:** The unknown function and its derivatives appear linearly.

$$\frac{\partial^2 u}{\partial x^2} + \frac{\partial^2 u}{\partial y^2} = 0$$

- **Nonlinear PDEs:** The unknown function or its derivatives appear nonlinearly.

$$\left(\frac{\partial u}{\partial x}\right)^2 + \frac{\partial^2 u}{\partial y^2} = 0$$

Common PDE Examples

1. **Heat Equation** (describes the distribution of heat over time):

$$\frac{\partial u}{\partial t} = \alpha \frac{\partial^2 u}{\partial x^2}$$

2. **Wave Equation** (models wave propagation):

$$\frac{\partial^2 u}{\partial t^2} = c^2 \frac{\partial^2 u}{\partial x^2}$$

3. **Laplace's Equation** (arises in electrostatics and fluid dynamics):

$$\frac{\partial^2 u}{\partial x^2} + \frac{\partial^2 u}{\partial y^2} = 0$$

PDEs are fundamental in physics, engineering, and many fields of applied mathematics.

A first-order partial differential equation (PDE) is a mathematical equation involving an unknown function of multiple variables, with partial derivatives of order one.

General Form:

A first-order PDE can be written in the general form:

$$F(x,y,u,p,q) = 0$$

where:

- x and y are independent variables
- $u = u(x,y)$ is the unknown function
- $p = \partial u / \partial x$ is the partial derivative of u with respect to x
- $q = \partial u / \partial y$ is the partial derivative of u with respect to y

Examples:

1. Linear first-order PDE:

$$\partial u / \partial x + a(x,y) \partial u / \partial y = b(x,y)$$

2. Quasilinear first-order PDE:

$$a(x,y,u) \partial u / \partial x + b(x,y,u) \partial u / \partial y = c(x,y,u)$$

3. Nonlinear first-order PDE:

$$(\partial u / \partial x)^2 + (\partial u / \partial y)^2 = f(x,y,u)$$

Methods to Solve First-Order PDEs:

1. Method of Characteristics
2. Separation of Variables
3. Integral Transform Methods (e.g., Laplace Transform, Fourier Transform)
4. Numerical Methods (e.g., Finite Difference Methods, Finite Element Methods)

Applications:

First-order PDEs arise in various fields, including:

1. Fluid Dynamics
2. Heat Transfer
3. Wave Propagation
4. Optics
5. Quantum Mechanics

A second-order partial differential equation (PDE) involves an unknown function of multiple variables, with partial derivatives of order two.

General Form:

A second-order PDE can be written in the general form:

$$F(x, y, u, p, q, r, s, t) = 0$$

where:

- x and y are independent variables
- $u = u(x, y)$ is the unknown function
- $p = \partial u / \partial x$ is the partial derivative of u with respect to x
- $q = \partial u / \partial y$ is the partial derivative of u with respect to y
- $r = \partial^2 u / \partial x^2$ is the second partial derivative of u with respect to x
- $s = \partial^2 u / \partial x \partial y$ is the mixed partial derivative of u with respect to x and y
- $t = \partial^2 u / \partial y^2$ is the second partial derivative of u with respect to y

Classification:

Second-order PDEs are classified based on the discriminant:

$$b^2 - 4ac$$

where a , b , and c are coefficients of the second-order terms.

- Elliptic ($b^2 - 4ac < 0$): e.g., Laplace equation
- Parabolic ($b^2 - 4ac = 0$): e.g., Heat equation
- Hyperbolic ($b^2 - 4ac > 0$): e.g., Wave equation

Examples:

1. Laplace equation (elliptic):

$$\nabla^2 u = \partial^2 u / \partial x^2 + \partial^2 u / \partial y^2 = 0$$

2. Heat equation (parabolic):

$$\partial u / \partial t = \alpha \partial^2 u / \partial x^2$$

3. Wave equation (hyperbolic):

$$\partial^2 u / \partial t^2 = c^2 \partial^2 u / \partial x^2$$

The Method of Characteristics (MOC) is a numerical technique used to solve partial differential equations (PDEs), particularly hyperbolic and parabolic equations. It's a powerful tool for solving problems involving wave propagation, fluid dynamics, and other physical phenomena.

Key aspects of the Method of Characteristics:

1. **Transformation:** The MOC transforms the PDE into a set of ordinary differential equations (ODEs) along characteristic curves.
2. **Characteristic curves:** These curves are paths in the solution space where the PDE becomes an ODE.
3. **Characteristic equations:** The ODEs along these curves are the characteristic equations.

Advantages:

1. **Accurate solutions:** MOC provides accurate solutions, especially for problems with smooth solutions.
2. **Stability:** The method is stable and less sensitive to numerical errors.
3. **Flexibility:** MOC can handle non-linear problems and complex boundary conditions.

Limitations:

1. **Computational complexity:** MOC can be computationally intensive, especially for multi-dimensional problems.
2. **Difficulty in handling shocks:** The method struggles with discontinuous solutions or shock waves.

Applications:

1. **Fluid dynamics:** MOC is used to study fluid flow, pressure waves, and shock waves.
2. **Aerodynamics:** The method helps analyze airflow, sonic booms, and supersonic flows.
3. **Wave propagation:** MOC models seismic waves, electromagnetic waves, and other types of wave propagation.

Separation of Variables (SoV) is a powerful method for solving partial differential equations (PDEs), particularly linear homogeneous PDEs with homogeneous boundary conditions.

Key aspects of Separation of Variables:

1. **Assumption:** The solution is assumed to be a product of separate functions of each independent variable.
2. **Separation:** The PDE is separated into ordinary differential equations (ODEs), one for each variable.
3. **Solution:** Each ODE is solved independently, and the solutions are combined to form the final solution.

Steps involved in Separation of Variables:

1. Assume the solution has the form $u(x,y) = X(x)Y(y)$

2. Substitute this into the PDE
3. Separate the variables
4. Solve the resulting ODEs
5. Apply boundary conditions

Advantages:

1. **Simplifies complex problems:** SoV reduces PDEs to simpler ODEs.
2. **Analytical solutions:** Provides exact solutions for certain problems.
3. **Physical insight:** Separation helps understand the physical behavior of the system.

Limitations:

1. **Limited applicability:** SoV only works for linear homogeneous PDEs with homogeneous boundary conditions.
2. **Coordinate restrictions:** The method is restricted to certain coordinate systems (e.g., Cartesian, polar).
3. **Difficulty with non-linear problems:** SoV struggles with non-linear PDEs.

Applications:

1. **Heat equation:** SoV solves heat conduction problems.
2. **Wave equation:** The method models vibrating strings, membranes, and other wave propagation problems.
3. **Laplace equation:** SoV is used in electrostatics, fluid flow, and potential theory.

Integral Transform Methods (ITMs) are powerful tools for solving partial differential equations (PDEs), integral equations, and other mathematical problems.

Key aspects of Integral Transform Methods:

1. **Transformations:** ITMs transform the original problem into a simpler one in a different domain.
2. **Integral transforms:** These include Fourier, Laplace, Mellin, and Hankel transforms.
3. **Inverse transforms:** The solution is transformed back to the original domain.

Types of Integral Transforms:

1. **Fourier Transform:** For problems with periodic or oscillatory behavior.
2. **Laplace Transform:** For problems involving time-dependent or exponential growth/decay.
3. **Mellin Transform:** For problems with boundary layers or singularities.

4. **Hankel Transform:** For problems involving cylindrical or spherical symmetry.

Steps involved in Integral Transform Methods:

1. Choose the appropriate transform.
2. Apply the transform to the PDE.
3. Solve the transformed equation.
4. Apply the inverse transform.

Advantages:

1. **Simplifies complex problems:** ITMs reduce PDEs to algebraic equations or ODEs.
2. **Analytical solutions:** Provides exact solutions for certain problems.
3. **Flexibility:** ITMs handle non-linear problems, boundary conditions, and discontinuities.

Limitations:

1. **Limited applicability:** ITMs require specific problem structures.
2. **Computational complexity:** Inverse transforms can be challenging.
3. **Convergence issues:** Transform convergence requires careful consideration.

Applications:

1. **Signal processing:** ITMs are used in filtering, modulation, and signal analysis.
2. **Control theory:** For system analysis, stability, and optimization.
3. **Fluid dynamics:** ITMs model fluid flow, heat transfer, and mass transport.
4. **Electromagnetics:** For wave propagation, scattering, and antenna analysis.

Some popular ITM techniques include:

- Fourier Analysis
- Laplace Transform Method
- Mellin Transform Method
- Hankel Transform Method
- Integral Equation Method

Chapter-V

SPECIAL METHODS AND APPLICATIONS

Dr.R.Abirami

*Asst. Professor in Mathematics
Ponnaiyah Ramajayam Institute of Science and Technology (PRIST)
Vallam, Thanjavur, Tamilnadu, South India*

Variational Methods Problems:

1. Find the minimum/maximum of the functional $\int(x^2 + y^2)dx$ from $x=0$ to $x=1$.
2. Solve the Euler-Lagrange equation for the functional $\int(y'^2 + y^2)dx$.
3. Use variational methods to solve the boundary value problem $y'' + y = 0$, $y(0) = 0$, $y(1) = 1$.

Perturbation Methods Problems:

1. Solve the equation $y'' + \epsilon y' + y = 0$ using perturbation methods.
2. Find the approximate solution to $y'' + y = \epsilon x$, $y(0) = 0$, $y(1) = 0$.
3. Use perturbation methods to solve the non-linear equation $y'' + y^2 = 0$.

Asymptotic Methods Problems:

1. Find the asymptotic expansion of the solution to $y'' + y = 0$ as $x \rightarrow \infty$.
2. Solve the equation $y'' + (1/x)y' + y = 0$ using asymptotic methods.
3. Use asymptotic methods to study the behavior of the solution to $y'' + y = \epsilon x$ as $\epsilon \rightarrow 0$.

Fluid Dynamics Problems:

1. Solve the Navier-Stokes equations for flow through a pipe.
2. Model the spread of a pollutant in a river using the advection-diffusion equation.
3. Use the Euler equations to study the flow around an airfoil.

Population Dynamics Problems:

1. Model the growth of a population using the logistic equation.
2. Solve the predator-prey equations for a specific ecosystem.

3. Use the SIR model to study the spread of a disease.

Electromagnetism Problems:

1. Solve Maxwell's equations for a waveguide.
2. Model the scattering of light by a sphere using the wave equation.
3. Use the Poisson equation to study the electric potential around a charge.

Quantum Mechanics Problems:

1. Solve the Schrödinger equation for a particle in a box.
2. Model the scattering of particles using the wave equation.
3. Use the Dirac equation to study the behavior of relativistic particles.

Computational Tools:

1. **MATLAB:** Numerical simulations, visualization.
2. **Python:** SciPy, NumPy, and Pandas for differential equations.
3. **Mathematica:** Symbolic and numerical computations.
4. **COMSOL:** Multiphysics simulations.

Physical Applications:

1. **Vibrations and Waves:** Strings, membranes, and structural dynamics.
2. **Fluid Flow:** Pipe flow, boundary layers, and turbulence.
3. **Heat Transfer:** Conduction, convection, and radiation.
4. **Electromagnetism:** Maxwell's equations, wave propagation.
5. **Quantum Mechanics:** Schrödinger equation, wave functions.

Biological and Social Applications:

1. **Population Dynamics:** Growth, decay, and interactions.
2. **Epidemiology:** Spread of diseases, vaccination strategies.
3. **Ecological Modeling:** Food chains, ecosystems.
4. **Social Network Analysis:** Information spread, opinion dynamics.
5. **Economic Modeling:** Growth, inflation, and resource management.

Engineering Applications:

1. **Control Systems:** Stability, optimal control.
2. **Signal Processing:** Filtering, modulation.
3. **Image Processing:** Diffusion, restoration.
4. **Structural Analysis:** Beams, plates, and shells.

5. **Computational Fluid Dynamics:** Simulation, visualization.

Real-World Problems:

1. **Climate Modeling:** Atmospheric circulation, ocean currents.
2. **Traffic Flow:** Congestion, optimization.
3. **Disease Spread:** Pandemic modeling, vaccination strategies.
4. **Financial Risk:** Option pricing, portfolio optimization.
5. **Materials Science:** Diffusion, phase transitions.

Case Studies:

1. **Modeling COVID-19 spread**
2. **Optimizing traffic flow**
3. **Analyzing climate models**
4. **Designing control systems**
5. **Simulating fluid dynamics**

VISUAL PROGRAMMING

EDITED BY

G.SANTHIYA JANCY



978-93-6255-760-5

Visual Programming

CopyRights@2023

G.Sandhya Jancy

All rights reserved.No part of this book may be reproduced or transmitted in any form or by any means without written permission from the author.

ISBN: 978-93-6255-056-9

Publisher : Ponnaiah Ramajayam Institute of Science and Technology[PRIST]

TABLE OF CONTENTS

| | |
|---|----|
| Chapter 1 Integrated Development Environment(Ide)Concepts..... | 01 |
| S.Sathiya Priya | |
| Chapter 2 Variables In Visual Basic..... | 02 |
| M.Aarthi | |
| Chapter 3 Selecting Using Controls..... | 03 |
| K.Vijayabaskar | |
| Chapter 4 The Image List Controls..... | 04 |
| D.S.Chozha Bharathi | |
| Chapter 5 Ole Properties..... | 05 |
| P.Karthik | |
| Chapter 6 Applications Of Visual Programming Language..... | 06 |
| P. Sakila | |
| Chapter 7 Difference Between Regular And Visual Programming Language...07 | |
| R. Suganya | |
| Chapter 8 The Foundations Of Visual Programming Languages..... | 08 |
| R. Kalaiselvi | |
| Chapter 9 Visual Programming For Web Apps With Bubble..... | 09 |
| G. Gayathri | |
| Chapter 10 Examples Of Visual Programming Languages..... | 10 |
| R. Rajayogeswari | |

CHAPTER 1 INTEGRATED DEVELOPMENT ENVIRONMENT

S. SATHIYA PRIYA

Assistant Professor, Department of Computer Science, Ponnaiah Ramajayam Institute of Science and Technology[PRIST],Thanjavur.

Any language that uses the graphics or blocks that are already defined with the code and you just need to use those blocks without worrying about the lines of code is known as a visual programming language. In today's era majority of the programming languages are text-based i.e. we have to write the lines of code to perform the specific task like in C or C++. programming if you want to print a table of 2 then you have to write the complete text using syntax and functions of that language but in visual programming language this task is replaced by graphics or blocks like components then can be joined logically to perform the task.

Visual Programming language lets the user think in a logical manner unlike in regular programming language the user has to think about that how he/she can explain the program to the computer, to do this let's take one small analogy like if you have to code multiplication table of 2 then in regular programming language what you will do is you will take the loop and with the help of it you can print the multiplication table but in the visual basic language you just have to add the block which has the inbuilt code in it of loop and you just specify the value and you just have to think logically and your work is done without worrying about the semicolon, syntax, functions, etc.

Examples of Visual Programming Language:

There are n numbers of visual programming languages and the few which are in the top list is given below

- **Scratch:** With the help of this language users can create, stories, games, and animations without writing any lines of code in this you just have to create the logic and assemble the blocks.
- **Blockly:** Used to create block-based programming language and editors, and also to generate code from blocks to javascript lua dart python and PHP, etc.
- **mBlock language:** It is used in programming robots.
- **Bubble language:** It is used to create web applications.
- **Minibloq language:** It is used as a graphical programming environment for Arduino.

CHAPTER 2 VARIABLES IN VISUAL BASIC

M.AARTHI

Assistant Professor, Department of Computer Science, Ponnaiah Ramajayam Institute of Science and Technology[PRIST],Thanjavur.

A variable is nothing but a name given to a storage area that our programs can manipulate. Each variable in VB.Net has a specific type, which determines the size and layout of the variable's memory; the range of values that can be stored within that memory; and the set of operations that can be applied to the variable.

We have already discussed various data types. The basic value types provided in VB.Net can be categorized as –

| Type | Example |
|----------------------|---|
| Integral types | SByte, Byte, Short, UShort, Integer, UInteger, Long, ULong and Char |
| Floating point types | Single and Double |
| Decimal types | Decimal |
| Boolean types | True or False values, as assigned |
| Date types | Date |

VB.Net also allows defining other value types of variable like **Enum** and reference types of variables like **Class**.

A *local variable* is one that is declared within a procedure. A *member variable* is a member of a Visual Basic type; it is declared at module level, inside a class, structure, or module, but not within any procedure internal to that class, structure, or module.

The [As](#) clause in the declaration statement allows you to define the data type or object type of the variable you are declaring. You can specify any of the following types for a variable:

- An elementary data type, such as Boolean, Long, or Decimal
- A composite data type, such as an array or structure
- An object type, or class, defined either in your application or in another application
- A .NET Framework class, such as [Label](#) or [TextBox](#)

CHAPTER 3 SELECTING USING CONTROLS

K.VIJAYABASKAR

Assistant Professor, Department of Computer Science, Ponnaiah Ramajayam Institute of Science and Technology[PRIST],Thanjavur.

To effectively write an event procedure for a control to respond to an event, it is necessary to configure specific properties that dictate its appearance and functionality. These properties can be set either through the properties window or dynamically during runtime.

In Figure 3.1, you'll find a standard properties window for a form. At the top, you'll see the currently selected object. The bottom part is divided into columns—the left lists various properties linked to the selected object, and the right displays their current states. To modify these properties, simply highlight and adjust the items in the right column by typing or selecting from the available options..

To modify the caption, simply highlight 'Form1' in the Caption section and replace it with your desired text. Additionally, you can customize the form's appearance by selecting either a 3D or flat style, adjusting foreground and background colors, changing the font type and size, toggling buttons for enable/disable, and managing minimize and maximize options, among other possibilities.

You may also change the properties at runtime to produce special effects such as change of color, shape, animation and more. Example 3.1 shows the code that will change the form color to red whenever the form is loaded. VB uses the hexadecimal system to specify the color. You can check the color codes in the properties windows corresponding to ForeColor and BackColor

Example 3.1: Program to change background color

This example changes the background colour of the form using the **BackColor property**.

```
Private Sub Form_Load()  
Form1.Show  
Form1.BackColor = &H000000FF&  
End Sub
```

This example is to change the control's Shape using the **Shape property**. This code will change the shape to a circle at runtime.

CHAPTER 4 IMAGE LIST CONTROLS

D.S.CHOZHABHARATHI

Assistant Professor, Department of Computer Science, Ponnaiah Ramajayam Institute of Science and Technology[PRIST],Thanjavur.

Image List control:

An ImageList Control contains a collection of images that can be used by other Windows Common Control

- It does not appear on the form at run time.
- It serve as a container for icon that are accessed by other control such as ListView,TreeView,TabStrip and ToolBar controls.

To add Image list control in the tool box:

- 1.Click on “Start” . Then select “All Programs, Microsoft Visual Studio 6.0 and Microsoft Visual Basic 6.0.” .
2. Select “Standard EXE” from the list in the New Project dialog box and click on “Open.” Click on “Project” on the menu bar, then select “Components” from the drop-down menu.
3. Scroll down the list in the box until Microsoft Windows Common Controls 6.0 (SP4) is visible. Click on the checkbox to select the component and then click on “OK.” All components show in the Toolbox.

To add Image List control in the form:

Choose the “ListView1” control from the list of controls in the toolbox. Place the control on the form in Visual Basic.

To add images to the image list control:

- Right click on Image control a popup menu is open choose properties option. A Properties Page is open .
- Click on Images Tab and insert the image as you want.
- To insert more than one picture then click on Insert Picture Button

CHAPTER 5 OLE PROPERTIES

P.KARTHIK

Assistant Professor, Department of Computer Science, Ponnaiah Ramajayam Institute of Science and Technology[PRIST],Thanjavur.

Coordinates (left-upper)

Use the options in the Coordinates group box to anchor the object either dynamically to a particular plot, or to make the placement of the object independent of the scaling in the graph. See [Anchoring Objects to Coordinates](#) for details regarding the distinction between dynamic and non-dynamic (fixed) anchoring of objects in graphs.

Dynamic (anchor to Plot)

Select the Dynamic check box to anchor the object dynamically to the plot selected in the Plot drop-down box (see [Anchoring Objects to Coordinates](#)).

Options for compound graphs

Compound graphs are those that consist of more than one graph and/or graph type in a single display, such as:

- Categorized plots (categorized by one or two variables)
- Matrix plots, such as matrix scatterplots, line plots, etc.
- Scatterplots with box-plots or Scatterplots with histograms

For these types of graphs, additional options exist to precisely control the location ("anchor point") where the extra graph object is to be attached. Note that different types of dialogs will be displayed depending on the type of compound graph to which you are attaching an object. Refer to [Extra Objects in Compound Graphs](#) for additional details.

Line

Select the Line check box to show the line for the object (circle, custom drawing, box, etc.). Click on the Line button to display the standard [Line Properties](#) dialog box, to customize the color and line type for the line.

Area

Select the Area check box to fill the background area for the object (circle, custom drawing, box, etc.); this is useful when you have gridlines included in the graph, and you don't want those lines to show behind and running through the object. Click on the fill Area button to display the standard [Area Properties](#) dialog box, to customize the background for the object.

Clip to graph frame

This option determines whether the respective extra graph object (e.g., line, text, etc.) will only be drawn inside the plot area of the graph, or whether it will also show outside the plot area, in the margins of the graph. If you select this check box, then the object will be "clipped" at the edges of the plot region for the graph, for example:

Clip to Graph Frame: OFF

CHAPTER 6 APPLICATIONS OF VISUAL PROGRAMMING

P.SAKILA

Assistant Professor, Department of Computer Science, Ponnaiah Ramajayam Institute of Science and Technology[PRIST],Thanjavur.

- **Usability and accessibility:** Visual programming environments typically have intuitive and user-friendly interfaces. By eliminating the need to write complex code, programming becomes more accessible to people who have little to no coding experience.
- **Rapid development and prototyping:** Because visual programming enables rapid prototype and iteration, users can quickly assemble and test components. It helps developers understand the impact of their development changes by providing real-time feedback and visualizing program execution.
- **Improved debugging:** Visual programming language debuggers highlight errors directly in the visual representation, making it easier to identify and resolve issues.
- **Visual development and traditional development** are two different approaches to creating software.
- Traditional development typically involves writing code in a text-based programming language, like as C++, Java, or Python. This code-based app development approach requires the developer to have a strong understanding of the language and its syntax, as well as the concepts of programming, such as data structures and algorithms.
- Visual development, on the other hand, uses visual elements, such as diagrams and flowcharts, to represent programming constructs. **Visual development environments** typically have drag-and-drop interfaces.
- Depending on the visual development tool and who it targets, it allows professional developers to accelerate their productivity, or users with no programming background to create software.
- For a long time, visual programming has had the reputation of being a teaching tool for beginners to get familiar with programming concepts, and to create simple user interfaces and prototypes. The reason for that has to do with its background.
- Visual programming's hype peaked in the early 90s with **CASE tools**. And, as with all trends ahead of their time, the repercussions of its failure were years of underinvestment, little innovation, and lingering skepticism.
- UML (Unified Modeling Language), with its promise of bringing sanity to object-oriented programming, hasn't helped either, although much of its faults were due to the underlying complexities related with inheritance.
- And even more recent trends, like Business Process Modeling, probably did more harm than good in giving credibility to this area.

CHAPTER 7 DIFFERENCE BETWEEN REGULAR AND VISUAL PROGRAMMING

R.SUGANYA

Assistant Professor, Department of Computer Science, Ponnaiah Ramajayam Institute of Science and Technology[PRIST],Thanjavur.

| Sr. No | Regular Languages | Visual Programming Language |
|-------------------|--|--|
| 1. | It is a programming language that only uses text. | It is a programming language that uses graphics or blocks in place of text. |
| 2. | It is not beginner-friendly language | It is a beginner-friendly language |
| 3. | Customization and flexible applications can be created using regular languages | There are not that much customizable as the blocks or graphics that contain the codes are limited and after that, we need to add our custom code as a block. |
| 4. | These are quite fast and efficient | This is not fast and efficient as every block has some code with it so it takes time and also it has graphics with it. |
| 5. | The interface is not good i.e. only text and syntax of language we have to get familiar with it. | The interface is great as the user has to just join the blocks and frame the logic without writing the code |
| 6 | requires time to learn as the user has to get familiar with the language syntax then code in it | any school student will be able to grasp the VPL and create the applications |
| 7. | Requires lot of efforts as a beginner to start with the language | Doesn't require a lot of effort and also the main targeted user of VPL is school level students so that they can love the coding |

CHAPTER 8 THE FOUNDATIONS OF VISUAL PROGRAMMING LANGUAGES

R.KALAISELVI

Assistant Professor, Department of Computer Science, Ponnaiah Ramajayam Institute of Science and Technology[PRIST],Thanjavur.

Those early programming days were difficult, to say the least. However, only one individual could comprehend and master all of the skills required to develop that application. Consider software titles from the 1980s if you're old enough. A single coder might easily become a superstar in their way. Today, apps are mostly created by groups of experts. Unlike early programmers who handled everything individually, a modern software development team may have one person whose sole responsibility is to manage the continuous integration tool. Programmers devote their whole careers to a unified model or platform. iOS developers are not mobile programmers; they are iOS programmers. A web developer could change their favorite framework once or twice in ten years. Only a few people make a living coding assembly language by hand.

The applicability of VPLs are growing in tandem with the growth of PCs and the capabilities of computer technology. While systems are getting software that can manage these computer languages, individuals are frequently too specialized in one programming language to properly employ visual programming. Humans excel at sketching things out to solve issues, but they find it difficult to think about a computer's size.

Visual programming had so much potential, but it fell short of those expectations in its early phases. They remain, nevertheless, more pertinent than ever. Visual programming may never be likely to substitute the better conventional programming languages because real-world issues need more adaptability than visual programming can provide. Hence to tackle the problems that VPL fell short of solving, low-code platforms were created. Low-code platform, on the other hand, are aiming to simplify programming and make it accessible to citizen developers. We consider that VPL is an integral element of current software development and that it will never go out of style.

CHAPTER 9 VISUAL PROGRAMMING FOR WEB APPS WITH BUBBLE

G.GAYATHRI

Assistant Professor, Department of Computer Science, Ponnaiah Ramajayam Institute of Science and Technology[PRIST],Thanjavur.

Visual programming is a method of web and software development that uses graphics and images, rather than purely text, to build out computing logic. It's been around for decades and represents another layer of machine language that our computers use when they talk with each other.

The main goal of early visual programming was to make it easier to use your computer. Before **graphical user interfaces** (GUIs) were invented, you had to type lines into a terminal window. Today, most people buy a "Mac" or "PC" and don't even think of their underlying computers as different from their visual operating systems.

Visual programming tools that let you build front-facing user interfaces are pretty commonplace, and it's easy to see how they make technology more accessible. In 2023, there are a lot of advanced visual front-end web development tools like Wix or Squarespace for creating websites, and design tools like Figma and Sketch for creating models and mockups.

But for building computational logic — like the kind you might find in a complex web application — visual programming's value has long been debated. Some argue that it's near impossible for visual programming logic to be as good as the power of a script-based language (aka writing code). The problem is, scripting languages take a lot more expertise than visual programming languages, which in turn limits the technology's potential.

That's why more and more people are turning to “no-code” software development tools like Bubble. And we're not talking about the visual UI-building tools for websites and prototypes listed above. **Bubble is, at its core, a true visual programming language** — with just as much power to create the logic for advanced software as text-based programming frameworks like React or Flask.

And flowchart-based logic systems like the early visual programming languages don't fare much better, with arrows and lines crossing a page that turn out to be more painful to look at than neat lines of script.

CHAPTER 10 EXAMPLES OF VISUAL PROGRAMMING LANGUAGES

R.RAJAYOGESWARI

Assistant Professor, Department of Computer Science, Ponnaiah Ramajayam Institute of Science and Technology[PRIST],Thanjavur.

Some visual programming examples include:

- **Scratch:** Primarily used in education, This language enables users, particularly children, to build interactive stories, games, and animations by snapping code blocks together.
- **Blockly:** This drag-and-drop programming tool can be used as a standalone application or integrated into web applications to create custom visual programming environments.
- **LabVIEW:** This National Instruments system design platform and development environment is commonly used in engineering, data acquisition, and industrial automation applications.
- **Unreal Engine's Blueprints:** This visual scripting system known as Blueprints from Epic Games enables game developers to create gameplay elements and logic without using traditional coding.
- **App Inventor:** This visual programming environment allows users to create [mobile apps](#) for Android devices using a drag-and-drop interface.
- For a long time, visual programming has had the reputation of being a teaching tool for beginners to get familiar with programming concepts, and to create simple user interfaces and prototypes. The reason for that has to do with its background.
- Visual programming's hype peaked in the early 90s with **CASE tools**. And, as with all trends ahead of their time, the repercussions of its failure were years of underinvestment, little innovation, and lingering skepticism.
- UML (Unified Modeling Language), with its promise of bringing sanity to object-oriented programming, hasn't helped either, although much of its faults were due to the underlying complexities related with inheritance.
- And even more recent trends, like Business Process Modeling, probably did more harm than good in giving credibility to this area.
- As [software development](#) becomes increasingly more complex, with new frameworks, technologies, devices and touchpoints to be considered, developers are ordinary people with extraordinary specializations.

That complexity and specialization are badly suited to the pure visual programming of those early tools, but it also makes it increasingly hard to build rounded software engineering teams. Yes, visual programming environments might have failed as they:

- Aren't extensible
- Generate slow-code



.NET PROGRAMMING

EDITED BY



R. KALAISELVI



978-93-6255-695-0

.Net Programming

Copyright © 2023 by R.Kalaiselvi

All rights reserved. No part of this book may be reproduced or transmitted in any form or by any means without written permission from the author.

ISBN: 978-93-6255-695-0

Publisher: Ponnaiyah Ramajayam Institute of Science and Technology (PRIST)

TABLE OF CONTENTS

| | |
|---|---|
| CHAPTER 1 Introduction to .Net Framework | 1 |
| Dr.P.Sathya | |
| CHAPTER 2 .Net Framework | 2 |
| Dr.K.Raja | |
| CHAPTER 3 Flow Controls in .Net..... | 3 |
| D.S.Chozha Bharathi | |
| CHAPTER 4 Interface with .Net Application..... | 4 |
| K.Priyadharshini | |
| CHAPTER 5 Forms and Controls in .Net | 5 |
| M.Aarthi | |
| CHAPTER 6 Database Access Control | 6 |
| P.Karthik | |
| CHAPTER 7 Desktop Application Development | 7 |
| G.Gayathri | |

CHAPTER 1
INTRODUCTION TO .NET FRAMEWORK
DR.P.SATHYA

Associate Professor, Department of Computer Science, Ponnaiyah Ramajayam Institute
of Science and Technology, Tamil Nadu, India.

The .NET Framework is a comprehensive software development platform developed by Microsoft, designed to create and run a wide range of applications, from web and mobile to desktop and cloud-based solutions.

At the heart of the framework is the Common Language Runtime (CLR), which provides a robust execution environment, managing memory, security, and exception handling for applications.

The framework also includes a rich class library that offers reusable code for common programming tasks, enabling developers to accelerate application development.

.NET supports multiple programming languages, including C#, F#, and VB.NET, allowing flexibility in language choice while ensuring seamless interoperability.

Over the years, the framework has evolved through various versions, incorporating enhancements in performance and security.

The transition to .NET Core and the unified platform of .NET 5 and later represents a significant shift towards cross-platform capabilities, enabling applications to run on Windows, macOS, and Linux.

Overall, the .NET Framework empowers developers with the tools, libraries, and support needed to build high-quality applications efficiently, making it a cornerstone of modern software development.

The .NET Framework is a comprehensive development platform created by Microsoft, designed to facilitate the development, deployment, and execution of applications across various devices and operating systems.

At its core, the framework provides a rich set of libraries and a robust runtime environment known as the Common Language Runtime (CLR).

Key components include:

CLR (Common Language Runtime): Acts as the execution engine, managing memory, security, and exception handling for .NET applications. It allows for code written in different languages to interoperate seamlessly.

Class Libraries: A vast collection of reusable classes and APIs that simplify common programming tasks, such as file handling, database access, and web development.

Language Support: .NET supports multiple programming languages, including C#, F#, and VB.NET, enabling developers to choose the language that best suits their needs while ensuring compatibility.

Development Tools: Visual Studio, the primary integrated development environment (IDE) for .NET, provides powerful tools for coding, debugging, and deploying applications.

Framework Versions: The framework has evolved through multiple versions, with enhancements in performance, security, and language features. The introduction of .NET Core and subsequently .NET 5 and beyond represents a shift towards cross-platform capabilities, allowing applications to run on Windows, macOS, and Linux.

CHAPTER 2

.NET FRAMEWORK

DR.K.RAJA

Associate Professor, Department of Computer Science, Ponnaiyah Ramajayam Institute
of Science and Technology, Tamil Nadu, India.

The .NET Framework is a robust and versatile software development platform created by Microsoft, designed to simplify the creation, deployment, and execution of applications across various environments.

At its core is the Common Language Runtime (CLR), which manages the execution of code and provides essential services like memory management, security, and exception handling.

The framework includes a comprehensive Base Class Library (BCL) that offers reusable classes and APIs for common programming tasks, enhancing developer productivity.

Supporting multiple programming languages, including C#, VB.NET, and F#, the .NET Framework enables developers to choose their preferred language while ensuring compatibility and interoperability.

Key components such as ASP.NET for web applications, Windows Presentation Foundation (WPF) for desktop applications, and Windows Communication Foundation (WCF) for service-oriented applications provide targeted functionalities to meet diverse development needs.

With built-in security features and a strong focus on scalability and performance, the .NET Framework has evolved through various versions, maintaining backward compatibility and adapting to modern software development practices.

Overall, it serves as a foundational platform that empowers developers to create high-quality applications efficiently, making it a cornerstone of contemporary software engineering.

.NET Framework Overview

The .NET Framework is a versatile software development platform created by Microsoft, designed to facilitate the creation, deployment, and execution of applications across various types of devices and environments. Here are the key components and features of the .NET Framework:

1. Common Language Runtime (CLR)

The CLR is the execution engine for .NET applications. It provides essential services such as memory management, garbage collection, security, and exception handling.

It enables the execution of code written in different languages, ensuring interoperability among them.

2. Base Class Library (BCL)

The BCL is a comprehensive collection of reusable classes, interfaces, and value types that provide a wide range of functionalities, including file I/O, data access, networking, cryptography, and more.

It simplifies common programming tasks, allowing developers to focus on application logic rather than low-level details.

3. Multi-language Support

The .NET Framework supports multiple programming languages, including C#, VB.NET, and F#. This allows developers to choose their preferred language while maintaining compatibility with the framework's libraries and tools.

4. Development Tools

Visual Studio is the primary integrated development environment (IDE) for .NET. It offers robust features for coding, debugging, and deploying applications.

CHAPTER 3

FLOW CONTROLS IN .NET

D.S.CHOZHA BHARATHI

Assistant Professor, Department of Computer Science, Ponnaiyah Ramajayam Institute
of Science and Technology, Tamil Nadu, India.

Flow control in .NET refers to the mechanisms that dictate the order in which instructions are executed within a program. These constructs enable developers to create dynamic and responsive applications by managing decision-making processes, loops, and branching logic.

Key flow control statements in .NET include:

Conditional Statements: Such as if, else, and switch, which allow the program to make decisions based on specific conditions. These statements enable branching logic, guiding the execution path based on variable states or user input.

Looping Statements: Including for, while, and do-while loops, which facilitate repeated execution of a block of code as long as a specified condition holds true. This is essential for tasks that require iteration, such as processing collections or performing repeated calculations.

Jump Statements: Such as break, continue, and return, which alter the flow of control within loops and methods. These statements provide mechanisms to exit loops prematurely, skip iterations, or return values from methods, enhancing the flexibility of code execution.

Exception Handling: Utilizing try, catch, and finally blocks to manage errors gracefully. This control structure allows developers to define how to respond to exceptions, ensuring that applications remain robust and user-friendly.

By effectively leveraging flow control constructs, developers can build complex logic into their applications, resulting in more interactive and efficient software solutions. Understanding these controls is fundamental to mastering .NET programming and enabling effective decision-making within applications.

Applications of Flow Controls in .NET

Interactive Applications: Flow controls manage user interactions in forms and applications. Conditional statements can show or hide UI elements based on user selections, improving usability.

Data Validation:

Input Validation: Use conditional statements to validate user input before processing. This ensures that only valid data is accepted, enhancing application stability and security.

Error Handling:

Robust Applications: Implement try, catch, and finally blocks to manage exceptions. This ensures that applications can recover gracefully from runtime errors, providing a better user experience.

Complex Algorithms:

Algorithm Implementation: Flow controls are crucial in implementing algorithms, such as sorting or searching, where decision-making and repetition are required.

Game Development:

Game Logic: In game development, flow controls dictate game states (e.g., menu, playing, paused) and handle user interactions, such as scoring and level progression.

Business Logic:

Rule-based Processing: In applications like CRM or ERP systems, flow controls are used to implement business rules, ensuring that operations adhere to defined processes.

Workflow Management:

Process Automation: Flow controls can automate workflows, such as approval processes in business applications, where different paths are taken based on conditions and user inputs.

CHAPTER 4

INTERFACE WITH .NET APPLICATION

K.PRIYADHARSHINI

Assistant Professor, Department of Computer Science, Ponnaiyah Ramajayam Institute
of Science and Technology, Tamil Nadu, India.

In .NET applications, an interface is a crucial programming construct that defines a contract for classes to implement, specifying a set of methods, properties, events, or indexers without dictating how they should be implemented.

This promotes a clean separation of concerns, enhancing modularity and flexibility in application design. Interfaces enable polymorphism, allowing different classes to be treated as instances of the same interface type, which is particularly useful in scenarios involving collections or generic programming.

They support loose coupling, making it easier to modify or replace implementations without impacting other components, thereby improving maintainability and scalability.

Additionally, interfaces facilitate multiple inheritance, enabling a class to implement multiple interfaces and fulfill various roles.

They are integral to event-driven programming, providing a standardized way for classes to define and handle events.

Furthermore, interfaces are essential in dependency injection patterns, enhancing testability by decoupling class implementations from their dependencies.

Overall, interfaces in .NET are fundamental for creating robust, flexible, and maintainable applications, serving as a backbone for object-oriented design principles.

An interface in .NET is a powerful construct that defines a contract for classes to implement, specifying a set of methods, properties, events, or indexers without providing their implementation. This abstraction promotes a clear separation of concerns, enhances code modularity, and facilitates flexible design patterns.

Key aspects of interfaces in .NET include:

Defining Contracts: Interfaces establish a formal agreement that any implementing class must fulfill, ensuring consistency across different implementations while allowing for varied behaviors.

Polymorphism: By using interfaces, .NET supports polymorphic behavior, enabling objects of different classes to be treated as instances of the same interface type. This is particularly useful in scenarios involving collections or frameworks that operate on generalized types.

Decoupling: Interfaces promote loose coupling between components, making it easier to change or replace implementations without affecting other parts of the system. This is essential for maintaining and scaling applications.

Multiple Inheritance: While classes in .NET cannot inherit from multiple base classes, they can implement multiple interfaces. This allows for a flexible design where a class can fulfill various roles.

Integration with Events: Interfaces are commonly used in event-driven programming, allowing classes to define and handle events in a standardized manner.

Dependency Injection: Interfaces play a crucial role in dependency injection patterns, enabling the injection of dependencies into classes without requiring knowledge of the concrete implementations, thus enhancing testability.

CHAPTER 5

FORMS AND CONTROLS IN .NET

M.AARTHI

Assistant Professor, Department of Computer Science, Ponnaiyah Ramajayam Institute
of Science and Technology, Tamil Nadu, India.

Forms and controls in .NET provide a robust framework for building interactive user interfaces (UIs) in applications, primarily within Windows Forms and Windows Presentation Foundation (WPF). Forms serve as the primary containers for UI elements, allowing developers to create visually appealing and user-friendly applications.

Controls are the building blocks of forms, encompassing various interactive elements such as buttons, text boxes, labels, and grids. They enable user input, display information, and facilitate interactions with the application. .NET offers a rich library of pre-defined controls, each designed to handle specific tasks and improve user experience.

Key features of forms and controls in .NET include:

Event-Driven Programming: Forms and controls operate on an event-driven model, where user actions (e.g., clicks, key presses) trigger events that can be handled by event handlers, allowing for responsive and interactive applications.

Data Binding: Controls can be easily bound to data sources, enabling automatic synchronization of UI elements with data, which simplifies the development of data-driven applications.

Customizability: Developers can customize controls through properties, methods, and events, allowing for tailored user experiences that meet specific application requirements.

Layout Management: .NET provides various layout controls (e.g., FlowLayoutPanel, Grid, Stack Panel) to manage the arrangement of controls within forms, ensuring that UIs are responsive and adaptable to different screen sizes.

Accessibility Features: Forms and controls support accessibility standards, allowing developers to create applications that are usable by individuals with disabilities.

Applications of Forms and Controls in .NET

Forms and controls in .NET are widely used in various application domains due to their flexibility and ease of use. Here are some key applications:

Desktop Applications:

User Interfaces: Forms are utilized to create the main user interface of desktop applications, providing a structured layout for interaction.

Data Entry Forms: Applications often include forms for users to input and edit data, such as customer information, orders, or product details.

In summary, forms and controls in .NET are essential for developing interactive applications, offering a wide range of features that enhance usability, data management, and overall user experience. Their flexibility and ease of use make them fundamental components of modern software development in the .NET ecosystem.

CHAPTER 6

DATABASE ACCESS CONTROL

P.KARTHIK

Assistant Professor, Department of Computer Science, Ponnaiyah Ramajayam Institute
of Science and Technology, Tamil Nadu, India.

Database Access Control is a crucial component in managing security and data integrity within applications that interact with databases.

It refers to the mechanisms and policies that govern how users and applications access and manipulate database resources.

Effective access control ensures that sensitive data is protected from unauthorized access while allowing legitimate users to perform necessary operations.

Key aspects of Database Access Control include:

Authentication: The process of verifying the identity of users or applications attempting to access the database. This can involve username/password combinations, tokens, or integrated security mechanisms.

Authorization: Once authenticated, authorization determines what actions users or applications can perform on the database, such as read, write, update, or delete permissions. Role-based access control (RBAC) is a common approach, assigning permissions based on user roles.

Granularity of Control: Access control can be applied at various levels, including database, table, and even row or column levels, allowing for fine-tuned control over who can access specific data.

Audit and Logging: Monitoring access to the database through logging can help identify unauthorized access attempts and provide accountability. Audit trails assist in compliance with regulatory requirements.

Encryption and Security Protocols: Implementing encryption for data at rest and in transit helps protect sensitive information from being intercepted or accessed by unauthorized users.

Dynamic Access Control: Some systems support dynamic access controls that adjust permissions based on contextual factors, such as the user's location, device, or time of access.

Applications of Database Access Control

Database Access Control is essential in various contexts to ensure the security and integrity of data. Here are some key applications:

Enterprise Resource Planning (ERP) Systems:

Access control mechanisms regulate who can view and modify sensitive data related to finance, inventory, and human resources, ensuring that only authorized personnel can access critical information.

Customer Relationship Management (CRM) Systems:

In CRM applications, access control helps manage customer data, allowing sales and support teams to access relevant information while protecting sensitive customer details from unauthorized users.

In summary, Database Access Control is essential for safeguarding sensitive information, ensuring compliance with regulations, and maintaining the overall security posture of applications that rely on database systems.

Effective access control mechanisms not only protect data but also enhance user trust and system reliability.

CHAPTER 7

DESKTOP APPLICATION DEVELOPMENT

G. GAYATHRI

Assistant Professor, Department of Computer Science, Ponnaiyah Ramajayam Institute
of Science and Technology, Tamil Nadu, India.

Desktop application development involves creating software applications designed to run on desktop or laptop computers, typically utilizing operating system resources and providing a rich graphical user interface (GUI) for user interaction.

This type of development encompasses various technologies, frameworks, and programming languages, allowing developers to build applications that meet specific user needs across different domains.

Key components of desktop application development include:

Frameworks and Technologies: Various frameworks, such as Windows Forms, WPF (Windows Presentation Foundation), and UWP (Universal Windows Platform) in the .NET ecosystem, provide tools and libraries that streamline the development process, enabling the creation of visually appealing and interactive applications.

User Interface Design: Emphasis on designing intuitive and responsive user interfaces that enhance user experience. This includes the use of controls, layout management, and event-driven programming to create interactive applications.

Data Management: Integration with databases and data sources is essential for many desktop applications. Developers implement CRUD operations, data binding, and data validation to ensure efficient data handling.

Security Considerations: Implementing security measures, such as authentication and authorization, is critical to protect sensitive data and ensure that applications comply with industry standards and regulations.

Cross-Platform Development: With the rise of technologies like Electron and .NET MAUI (Multi-platform App UI), developers can build cross-platform desktop applications that run on multiple operating systems, including Windows, macOS, and Linux.

Deployment and Maintenance: Effective deployment strategies, including installer creation and update management, are crucial for ensuring that applications are easily installed and maintained on user machines.

In summary, desktop application development encompasses a wide range of practices and technologies that enable the creation of robust, user-friendly software for personal and business use.

As technology continues to evolve, developers are increasingly leveraging modern frameworks and cross-platform tools to meet the diverse needs of users in the desktop environment.

SOFTWARE TESTING

Edited by
SIVAGAMI . E



978-93-6255-088-8

NETWORK BASICS

Copyright@2023 by Sivagami.E

All rights reserved. No part of this book may be reproduced or transmitted in any form or by any means without written permission from the author.

ISBN: 978-93-6255-008-8

Publisher: Ponnaiah Ramajayam Institute of Science and Technology[PRIST]

TABLE OF CONTENTS

| | |
|---|----|
| CHAPTER 1: Testing Principles: Ensuring Software Quality Across Development Lifecycle Models..... | 1 |
| P. karthik | |
| CHAPTER 2: Testing Dimensions: Navigating White Box, Black Box, Integration, and System Acceptance Testing..... | 3 |
| G. Gayathri | |
| CHAPTER 3: Beyond the Basics: Unleashing Performance, Regression, Internationalization, and Adhoc Testing Strategies..... | 5 |
| R. Rajayogeswari | |
| CHAPTER 4: Strategic Testing: Planning, Management, Process, and Reporting for Effective Software Quality Assurance..... | 7 |
| P. Sakila | |
| CHAPTER 5: Quantifying Quality: Test Metrics and Measurements for Software Evaluation..... | 9 |
| R. Kalaiselvi | |
| CHAPTER :6 Testing deployment process..... | 11 |
| H. Parveenbegam | |
| CHAPTER 7: Testing automation frame work | 13 |
| K. Priyadharshini | |
| CHAPTER 8: Testing report..... | 15 |
| Mrs.S. sathya priya | |

CHAPTER-1

Testing Principles: Ensuring Software Quality Across Development Lifecycle Models

P. karthik

(Assistant Professor, Department of Computer science, Ponnaiah Ramajayam Institute of Science and Technology[PRIST], Thanjavur.)

Testing principles:

Software testing is complex and resource-intensive. Naturally, you want to optimize your testing process to get the best quality on your testing investment. The seven principles of testing help you set optimum quality standards and give you and your customers confidence that the software is ready for action.

1. Testing shows the presence of defects, not their absence

If your QA team reports zero defects after the testing cycle, it does not mean there are no bugs in the software. It means that there could be bugs, but your QA team did not find them. The reasons for not detecting any defects could be many, including the most common one - the test cases do not cover all scenarios.

This principle helps in setting stakeholder expectations. Don't make claims that the software is [defect-free](#).

2. Exhaustive testing is impossible

Consider a simple real-world example in which you have a screen that takes two numbers as input and prints their sum. It would take infinite time to validate this screen for all possible numbers.

3. Early testing saves time and money

The proverb: a stitch in time saves nine, applies to most things in life, and software testing is no exception. As shown in a study conducted by IBM, what costs a dollar to fix in the design phase can cost fifteen in the testing phase and a whopping hundred if detected in a production system.

4. Defects cluster together

This principle is an example of the 80:20 rule (also called the Pareto principle) – 80 percent of defects are due to 20 percent of code. While most believe this is some divine mandate, it is based on the observation that 80 percent of users use 20 percent of the software. It is this 20 percent of the software that will contribute most towards the defects.

CHAPTER-2

. Testing Dimensions: Navigating White Box, Black Box, Integration, and System Acceptance Testing

G. Gayathri

(Assistant Professor, Department of Computer science, Ponnaiah Ramajayam Institute of Science and Technology[PRIST], Thanjavur.)

TESTING DIMENSIONS:

Black-box testing is a kind of software testing that verifies if the software works for end-users as intended, without being concerned about its inner workings.

When is black-box testing used?

In most test cases where black-box testing is used, it falls under the following categories:

Functional Testing

In [functional testing](#), you test every feature of the software to see if it works as expected. An example of functional testing is the testing of a website. You need to make sure all the website components, such as web pages, links, and sign-up forms, are functional.

Non-functional Testing

In [non-functional testing](#), you aim to test the performance and usability of the software. After the website's initial development, you need to check it for responsiveness, speed, and usability.

Regression Testing

[Regression testing](#) is done after code fixes, software upgrades, or any other system maintenance to check whether the new code has affected the existing code or not.

Techniques of Black box testing

We know how impactful and beneficial Black box testing can be to the organization in improving the quality of its software application. There are many techniques of Black box testing available for fulfilling software testing requirements. Let's have a look at the popular ones to include in the test strategy.

1. Equivalence Partitioning

In this type of Black box testing technique, the inputs that behave homogeneously or yield similar outcomes are divided and grouped under one category. One input value from each group is picked and tested. For every group, one representative value is selected and tested. Testing each value in the group would be time-consuming. In this technique, only the representative value is tested from each group, making it easier to test many inputs at once, maintaining test coverage, and reducing rework.

CHAPTER-3

. Beyond the Basics: Unleashing Performance, Regression, Internationalization, and Adhoc Testing Strategies

R. Rajayogeswari

(Assistant Professor, Department of Computer science, Ponnaiah Ramajayam Institute of Science and Technology[PRIST], Thanjavur.)

What is a Test Strategy?

A test strategy is a high-level document that outlines the overall approach and guiding principles for software testing. It provides a structured framework that directs the testing team on how to efficiently and effectively conduct tests, ensuring that all key aspects of the software are validated.

Benefits of Test Strategy

1. Provides clear direction and focus for testing activities.
2. Identifies and mitigates critical risks early.
3. Streamlines processes, optimizing resource use and timelines.
4. Promotes adherence to industry and regulatory standards.
5. Enhances teamwork by aligning all members with project goals.
6. Aids in effective allocation of resources.
7. Facilitates efficient monitoring and reporting of test progress.
8. Ensures comprehensive validation of all critical functionalities.

Types of Test Strategy

1. Static vs Dynamic Test Strategy

Here we encounter a dual approach to software testing. Static testing involves evaluating code or documents without execution (catching issues early), while dynamic testing requires actually running the software to validate its behavior in real scenarios.

2. Preventive vs. Reactive Test Strategy

As the name suggests, we want to strike a balance between anticipating potential defects vs responding to issues after they have occurred.

CHAPTER-4

Strategic Testing: Planning, Management, Process, and Reporting for Effective Software

Quality Assurance

P. Sakila

(Assistant Professor, Department of Computer science, Ponnaiah Ramajayam Institute of Science and Technology[PRIST], Thanjavur.)

SQA Processes and Techniques:

Software Quality Assurance (SQA) involves various processes and techniques that help ensure the quality of software throughout the development lifecycle. These methodologies are designed to prevent defects, ensure functionality meets specified requirements, and maintain a high standard of software performance. Here's an in-depth look at some key SQA processes and techniques:

1. Code Reviews

Code reviews are a critical SQA activity where other developers (peers) review the source code written by a developer before it merges into the main branch. This practice aims to catch errors early in the development phase, promote a higher code quality standard, and share knowledge across the team. Benefits include:

2. Automated Testing

Automated testing uses software tools to run tests on the software automatically, checking for errors, defects, and functional mismatches. This can include:

3. Continuous Integration and Continuous Delivery (CI/CD)

CI/CD is a method to frequently deliver apps to customers by introducing automation into the stages of app development. The main concepts attributed to CI/CD are continuous integration, continuous delivery, and continuous deployment. CI/CD is intended to:

CHAPTER-5

Quantifying Quality: Test Metrics and Measurements for Software Evaluation.

R. Kalaiselvi

(Assistant Professor, Department of Computer science, Ponnaiah Ramajayam Institute of Science and Technology[PRIST], Thanjavur.)

Test Metrics:

Software engineers perform various tests to assess the quality of the developed product and ensure that it works as intended. They use several test metrics to evaluate the efficiency and effectiveness of their software testing techniques. If you work as a quality assurance (QA) tester or in a similar role, learning various software testing metrics can help you measure and monitor the testing process.

Test metrics are indicators of the efficiency, effectiveness, quality and performance of software testing techniques. These metrics allow professionals to collect data about various testing procedures and devise ways to make them more efficient. It also allows them to improve testing techniques in various aspects of a product, such as its quality, security, customer satisfaction, development cost and performance.

The life-cycle of creating a software testing metric is:

Analysis: Testing professionals devise a metric to test the effectiveness of their testing methods.

Communication: This stage involves presenting the metric to the management and stakeholders for approval.

Evaluation: Professionals evaluate the metric using an extensive data set in this step.

Report: This step involves creating a detailed report on the metric, including its formula, experiments and results.

Benefits of Software Testing Metrics

Here are some benefits of using software testing metrics:

Save time

Testing is an integral part of the product development process. By using various software testing metrics, it is possible to identify testing techniques that are time-consuming. The testing team can then thoroughly analyse these techniques and identify ways to optimize them. This helps shorten the software development lifecycle and improves a product's time to market.

CHAPTER-6

Testing deployment process

H. Parveenbegam

(Assistant Professor, Department of Computer science, Ponnaiah Ramajayam Institute of Science and Technology[PRIST], Thanjavur.)

Deployment Testing in Software Testing:

At the last stage of the software development life cycle comes the deployment stage. This is where the team migrates software from the controlled development and staging environments to production (the technical term for “the real world”).

Deployment testing in software testing is the final line of defense against sneaky bugs, unidentified so far. This layer of testing prevents them from filtering into production and ruining software quality where it really counts. It is essential to keep users happy, maintain brand credibility and drive revenue.

In the absence of deployment testing, you might reduce time-to-market, but you’ll end up with a bug-ridden app, customer complaints, higher costs of bug fixes, and 1-star ratings. Hence, QA teams must be equipped with the required tools, knowledge, and structure required to successfully run deployment tests.

The Stages of Deployment

Pre-deployment

This stage comprises all stages before deployment. It’s essential that you identify and fix as many bugs as possible before the software hits production. Not only does this improve user experience, but also keeps your budget from fizzing into thin air – it’s cheaper to fix bugs in the early stages. Even if you somehow encounter a major bug right before the deployment date and time, it’s cheaper & faster to address it in a controlled environment.

Pre-deployment testing methods

There are many more tests you could run at the pre-deployment stage. Below we mention the most important ones:

Functional Testing:

A black box testing method meant to verify that all functions of the software work in accordance with predetermined requirements that meet business goals. The software is fed a wide range of data inputs that verify how each function responds, and whether the response matches expectations.

CHAPTER-7

Testing automation frame work

K. Priyadharshini

(Assistant Professor, Department of Computer science, Ponnaiah Ramajayam Institute of Science and Technology[PRIST], Thanjavur.)

Test Automation Frameworks

Testing frameworks are an essential part of any successful automated testing process. They can reduce maintenance costs and testing efforts and will provide a higher return on investment (ROI) for QA teams looking to optimize their agile processes.

The goal of this article is to walk through the most common types of frameworks used today and the benefits and disadvantages of each. For QA professionals new to automated testing, or those who need a quick refresher, this article will provide a high-level overview of each type of framework and how they can contribute to the success of any automated testing process.

What is a Test Framework?

Before diving into the most common types of frameworks and their benefits, let's clarify what a test automation framework actually is. A testing framework is a set of guidelines or rules used for creating and designing test cases. A framework is comprised of a combination of practices and tools that are designed to help QA professionals test more efficiently.

These guidelines could include coding standards, test-data handling methods, object repositories, processes for storing test results, or information on how to access external resources.

While these are not mandatory rules and testers can still script or record tests without following them, using an organized framework typically provides additional benefits that would otherwise be missed out on.

Benefits of a Test Automation Framework

Utilizing a framework for automated testing will increase a team's test speed and efficiency, improve test accuracy, and will reduce test maintenance costs as well as lower risks.

CHAPTER-8

Testing report

Mrs.S. sathya priya

(Assistant Professor, Department of Computer science, Ponnaiah Ramajayam Institute of Science and Technology[PRIST], Thanjavur.)

Test Report:

Test Reports were originally started to be used in Waterfall Models. Still, nowadays, teams have started adopting it in Agile Development processes too, which has proved to be of great help.

A test report summary contains all the details of the testing process, what was tested, when was it tested, how it was tested, and the environments where it was tested. Compared to those created in the Waterfall versions, the test summary report in Agile development processes is less formal and more focused on the results.

Test Summary Report

The definition of a Test Summary is as simple as the name suggests. It is also known as a Test Closure Report. It provides the relevant stakeholders with a detailed account of the overall test results and defects. It aims to summarize the results of the entire testing process formally.

Test Summary Report is an important document that is prepared at the end of a Testing project, or rather after the Testing cycle has been completed. The prime objective of this document is to explain the details of the Testing activities performed for the Project, to the respective stakeholders like Senior Management, Clients, etc. It also portrays the overall quality level of the application.

While the Daily Status Reports only deliver the daily test status and results to the stakeholders, Test Summary Report on the other hand provides a consolidated report on the overall testing activities performed in the cycle.

Write a Good Test Summary Report

As businesses get bigger, good test summary reporting is essential to analyze both the bugs and the process associated with testing. But creating an informative, easily understandable, and concise report given the number of different users of the report can be challenging. Test reports are detailed summaries of everything happening in software projects. They tell us where the QA teams are checking the test code, who's doing the testing, and how and when tests are happening. They can also help you keep track of code changes and bugs.

If the team does this part well and on time, the report and feedback become helpful throughout building the software. Below, we'll spell out best practices explaining how you can produce a worthwhile test summary report.



NETWORK BASICS

EDITED BY

E. SIVAGAMI



978-93-6255-616-5

NETWORK BASICS

Copyright@2023 by Sivagami.E

All rights reserved. No part of this book may be reproduced or transmitted in any form or by any means without written permission from the author.

ISBN: 978-93-6255-616-5

Publisher: Ponnaiah Ramajayam Institute of Science and Technology[PRIST]

TABLE OF CONTENTS

| | |
|--|----|
| CHAPTER 1: Unveiling the Basics: A Primer on Transmission Fundamentals | 1 |
| R. Suganya | |
| CHAPTER 2: Navigating the Network Landscape: Understanding Protocols and the TCP/IP Suite | 3 |
| K. Vijayabaskar | |
| CHAPTER 3: Wireless Wonders: Unraveling Antennas, Propagation, and Signal Techniques for Reliable Communication | 5 |
| P. Karthik | |
| CHAPTER 4: Connecting the Airwaves: Exploring Satellite, Cellular, and Cordless Networks with Mobile IP and Wireless Access Protocols | 7 |
| R. Rajayogeswari | |
| CHAPTER 5: Wireless LAN Wonders: Delving into Wi-Fi, IEEE 802.11, Bluetooth, and IEEE 802.15 Standards | 9 |
| R. Kalaiselvi | |
| CHAPTER 6 configuring IP Address on networks | 11 |
| H. Parveenbegam | |
| CHAPTER 7: Troubleshooting in Networking | 13 |
| Mrs.Sathyapriya | |
| CHAPTER 8: Secure Networking | 15 |
| K. Priyadharshini | |

CHAPTER-1

Unveiling the Basics: A Primer on Transmission Fundamentals

R. Suganya

(Assistant Professor, Department of Computer science, Ponnaiah Ramajayam Institute of Science and Technology[PRIST], Thanjavur.)

At first blush that may sound like a contradiction in terms, or perhaps a wild conjecture intended only to grab your attention to get you to read on. After all, the Internet is a modern day technical marvel. In just a couple of decades the Internet has not only transformed the global communications sector, but its reach has extended for further into our society, and it has fundamentally changed the way we do business, the nature of entertainment, the way we buy and sell, and even the structures of government and their engagement with citizens. In many ways the Internet has had a transformative effect on our society that is similar in scale and scope to that of the industrial revolution in the 19th century.

You see it is all about addresses. In a communications network that supports individual communications its essential that every reachable destination has its own unique address. For the postal network it's commonly your street address. For the traditional telephone network, it's your phone number. This address is not just how other users of the network can select you, and only you, as the intended recipient of their communication. It's how the network itself can ensure that the communication is correctly delivered to the intended recipient. The Internet also uses addresses. In fact, the Internet uses two sets of addresses. One set of addresses is for you and I to use. Domain names are the addresses we enter into web browsers, or what we use on the right hand side of the @ in an email address. These addresses look a lot like words in natural languages, which is what makes them so easy for we humans to use. The other set of addresses are used by the network. Every packet that is passing through the Internet has a digital field in its header that describes the network address of the packet's intended delivery address: it's "destination address." This address is a 32-bit value. A 2-bit field has four possible values, a 3-bit field has eight possible values, and by the same arithmetic a 32-bit field has 2 to the power 32, or some 4,294,967,296 unique values.

Running out of addresses in any communications network can pose a massive problem. We have encountered this a number of times in the telephone network, and each time we've managed to add more area codes, and within each area we've added more in-area digits to telephone numbers to accommodate an ever-growing population of connected telephone handsets.

CHAPTER-2

Navigating the Network Landscape: Understanding Protocols and the TCP/IP Suite

K. Vijayabaskar

(Assistant Professor, Department of Computer science, Ponnaiah Ramajayam Institute of Science and Technology[PRIST], Thanjavur.)

Introduction:

TCP/IP is a set of protocols and applications that enable you to perform certain computer functions in a similar manner independent of the types of computers or networks being used. When you use TCP/IP, you are using a network of computers to communicate with other users, share data with each other, and share the processing resources of the computers connected to the TCP/IP network.

A computer network is a group of computer nodes electronically connected by some communication medium. Each node has the hardware and the programs necessary to communicate with other computer nodes across this communication medium. The node can be a PC, workstation, departmental computer, or large computer system. The size of the computer is not important. The ability to communicate with other nodes is important.

Computer networks enable you to share the data and computing resources of many computers.

Applications, such as departmental file servers, rely on networking as a way to share data and programs.

Many forms of communication media are available today. Each is designed to take advantage of the environment in which it operates. Communication media consist of a combination of the physical network used to connect the computer nodes and the language, or protocol, they use to communicate with each other.

Understanding the TCP/IP Model in Action

TCP/IP's significance lies in its ability to facilitate data transfer and communication across various networks, regardless of the receiver's location. IP ensures the successful delivery of data packets to their intended destinations, while TCP manages data transfer, ensuring reliable connections between data streams and applications.

CHAPTER-3

Wireless Wonders: Unraveling Antennas, Propagation, and Signal Techniques for Reliable Communication.

P. Karthik

(Assistant Professor, Department of Computer science, Ponnaiah Ramajayam Institute of Science and Technology[PRIST], Thanjavur.)

Signal

The physical representation of data by the transmission of which communication takes place is known as signal. The representation can be electrical, electronic or optical. Voice, images, letters or numbers can be represented using signals. Signal can be analog or digital.

Factors affecting strength and path of EM waves

- 1.Distance between transmitter and receiver
- 2.Frequency/wavelength of wave
- 3.Earth's atmosphere
- 4.Environmental objects
- 5.Signal Propagation modes

A signal on its journey from transmitter to receiver propagates in three modes. Type of Propagation is determined by the carrier frequency.

- 1.Ground waves or surface waves propagation
- 2.Sky waves or Ionosphere propagation
- 3.Space waves or Line-of-sight propagation
- 4.Ground Waves Propagation also known as Surface Wave (<2MHz)

Waves with low frequencies follow the earth's surface. Due to very less frequency range, also known as low frequency/medium waves. Antennas are bigger in size and located near the ground. They follow curvature of the Earth. These waves are used in Submarine Communication, A.M radio.

Phenomena effecting signal propagation

When a signal travels in free space, it behaves like light. It travels straight from sender to receiver. But in real scenario signal in mobile communication, Wi-Fi and other networks have to come across various objects in atmosphere, environment and other surroundings like mountains, buildings, furniture, rain water molecules of atmosphere layer and many others.

CHAPTER-4

Connecting the Airwaves: Exploring Satellite, Cellular, and Cordless Networks with Mobile IP and Wireless Access Protocols.

R. Rajayogeswari

(Assistant Professor, Department of Computer science, Ponnaiah Ramajayam Institute of Science and Technology[PRIST], Thanjavur.)

Wireless application protocol:

Mobile commerce is becoming increasingly important in business. Wireless application protocol (WAP) is one of the most widespread technical standards for mobile commerce. Following continuous technical evolution, WAP has now included various new features. However, WAP services continue to struggle for market share. Hence, understanding the adoption of WAP services is increasingly important for enterprises interested in developing mobile commerce.

This study aims to: (i) identify the critical factors of WAP services adoption; (ii) explore the relative importance of each factor between WAP adopters and non-adopters; and (iii) examine the causal relationships among variables on WAP services adoption behavior.

This study reports empirical test of the adoption of WAP services in Taiwan, based on the theory of planned behavior and innovation diffusion theory.

The results indicate that the critical factors influencing the adoption of WAP services include connection speed, service costs, user satisfaction, personal innovativeness, ease of use, peer influence, and facilitating conditions. Some suggestions for subsequent researchers and practitioners seeking to understand WAP services adoption behavior are also provided.

Mobile commerce involves the delivery of products and services via wireless technologies to enable e-commerce activities without restrictions of time and space.

Several independent studies have shown that mobile commerce can have an important influence on business and society in the future. The Internet has proven an easy and efficient means of delivering e-commerce services to millions of 'wired' users. However, the need to be 'wired' limits the scope of e-commerce. Wireless platforms are required to enable e-commerce anytime, anywhere, and anyway. In the field of mobile commerce technologies, wireless application protocol (WAP) is undoubtedly one of the most popular mobile commerce protocols.

CHAPTER-5

Wireless LAN Wonders: Delving into Wi-Fi, IEEE 802.11, Bluetooth, and IEEE 802.15 Standards

Mrs. R. Kalaiselvi

(Assistant Professor, Department of Computer science, Ponnaiah Ramajayam Institute of Science and Technology[PRIST], Thanjavur.)

Wi-Fi and IEEE 802.11

Wi-Fi refers to a family of wireless networking technologies based on the IEEE 802.11 standards. Here are some key points:

1. Evolution:

- **802.11b** (1999): Introduced speeds up to 11 Mbps in the 2.4 GHz band.
- **802.11g** (2003): Combined the best of 802.11a and b, offering speeds up to 54 Mbps.
- **802.11n** (2009): Used multiple antennas (MIMO) to achieve speeds up to 600 Mbps, operating in both 2.4 GHz and 5 GHz bands.
- **802.11ac** (2013): Provided even higher speeds (up to several Gbps) and improved performance in crowded areas, primarily in the 5 GHz band.
- **802.11ax** (Wi-Fi 6, 2019): Enhanced performance in dense environments, with speeds exceeding 10 Gbps, improved battery life for devices (OFDMA), and better efficiency.

2. Key Features:

- **Range and Speed:** Varies by standard and frequency band (2.4 GHz vs. 5 GHz).
- **Security:** WPA3 enhances security for users by providing stronger encryption and protection against brute-force attacks.
- **Mesh Networking:** Modern routers support mesh networking for broader coverage and better signal strength in larger spaces.

Bluetooth and IEEE 802.15

Bluetooth is a standard for short-range wireless communication, defined by the IEEE 802.15 standards. Here's a closer look:

1. Evolution:

- **Bluetooth 1.0/1.1:** Established basic functionality (up to 721 Kbps) but had some interoperability issues.
- **Bluetooth 2.0 + EDR:** Enhanced Data Rate allowed speeds up to 3 Mbps.
- **Bluetooth 4.0:** Introduced Bluetooth Low Energy (BLE), focusing on low power consumption for devices like wearables.
- **Bluetooth 5.0:** Improved range (up to 240 meters) and speed (up to 2 Mbps), enabling applications like smart home devices.

2. Key Features:

- **Low Energy Consumption:** Ideal for IoT devices, allowing for extended battery life.
- **Wide Range of Applications:** Used in headphones, fitness trackers, smart home devices, and more.
- **Data Transfer:** Allows for the transfer of small amounts of data over short distances, with profiles tailored for different use cases (e.g., audio, health data).

CHAPTER 6

configuring IP Address on networks

H. Parveenbegam

(Assistant Professor, Department of Computer science, Ponnaiah Ramajayam Institute of Science and Technology[PRIST], Thanjavur.)

IP Address:

An **Internet Protocol (IP) address** is the unique identifying number assigned to every device connected to the internet. An IP address definition is a numeric label assigned to devices that use the internet to communicate. Computers that communicate over the internet or via local networks share information to a specific location using IP addresses.

IP addresses have two distinct versions or standards. The Internet Protocol version 4 (IPv4) address is the older of the two, which has space for up to 4 billion IP addresses and is assigned to all computers. The more recent Internet Protocol version 6 (IPv6) has space for trillions of IP addresses, which accounts for the new breed of devices in addition to computers. There are also several types of IP addresses, including public, private, **static, and dynamic IP addresses**.

Every device with an internet connection has an IP address, whether it's a computer, laptop, IoT device, or even toys. The IP addresses allow for the efficient transfer of data between two connected devices, allowing machines on different networks to talk to each other.

How does an IP address work?

An IP address works in helping your device, whatever you are accessing the internet on, to find whatever data or content is located to allow for retrieval.

Common tasks for an IP address include both the identification of a host or a network, or identifying the location of a device. An IP address is not random. The creation of an IP address has the basis of math. The Internet Assigned Numbers Authority (IANA) allocates the IP address and its creation. The full range of IP addresses can go from 0.0.0.0 to 255.255.255.255.

With the mathematical assignment of an IP address, the unique identification to make a connection to a destination can be made.

CHAPTER-7

Trouble Shooting in Networking

Mrs.Sathyapriya

(Assistant Professor, Department of Computer science, Ponnaiah Ramajayam Institute of Science and Technology[PRIST], Thanjavur.)

In recent years, numerous businesses and enterprises have been riding on a mega wave of rapid technological expansion with advanced networks serving as backbones in delivering mission-critical services to end-users worldwide.

The development of small and medium businesses to large enterprises, surging demands and increased market size causes network infrastructures to ever adapt and evolve. In the process, businesses hire more employees, open branch offices, expand into global markets and centralize network management in a Network Operations Center (NOC).

The role of network troubleshooting in the evolution of enterprise network infrastructure

This growth can cause network issues on existing components due to heavy workloads and improper adaptation of new technologies. It could be a faulty or damaged cable, a routing problem due to misconfiguration, an over-utilized link, misconfiguration of IP addresses or subnet masks, etc. End-users also expect enterprises to provide 99.99 percent uptime and a network outage can result in loss of revenue, customers, data and business opportunities, while incurring huge costs on network expansion.

An IT admin requires sophisticated network troubleshooting software which identifies and prevents network disruptions and delivers on Service Level Agreements (SLA).

The need for robust and comprehensive network troubleshooting tool

Types of network troubleshooting tools

These network troubleshooting tools range from simple command line based troubleshooting utilities to more comprehensive and robust solutions that allows for a systematic, efficient and proactive approach to network troubleshooting, e.g. Manage Engine Manager.

CHAPTER-8

Secure Networking

K. Priyadharshini

(Assistant Professor, Department of Computer science, Ponnaiah Ramajayam Institute of Science and Technology[PRIST], Thanjavur.)

Secure Digital Acceleration

Growing and scaling digital business while protecting a distributed infrastructure has never been more critical or complex. Networks today are center of innovation and enable digital acceleration using network modernization. Fortinet's Secure Networking converges networking technologies with AI-powered security across all edges to close security gaps and help organizations achieve better user experience.

Fortinet's Secure Networking

Digital acceleration has led to a rapid expansion of attack surfaces and creation of new network edges, including LAN, WAN, 5G, remote workers, and clouds. Fortinet's Secure Networking approach is the industry's only converged networking and security platform. This convergence enables AI-powered defense of today's highly dynamic environments while enabling better productivity and user experience.

Leading Innovations of Networking and Security

The FortiGate NGFW is the core component of Secure Networking. FortiGate is powered by the **FortiOS operating system** and purpose-built **security processors** (SPUs). These innovations enable the most complete convergence of networking and security by eliminating the need for point products. Our unified offering of SD-WAN, NGFW, SWG, ZTNA enforcement, LAN and WLAN, and wireless WAN 5G/LTE are available to deploy on any network edge.

FortiGuard Labs monitors the worldwide attack surface and employs AI to mine data for new threats, ensuring you are prepared for what's coming. Our threat experts work around the clock to develop, enhance, and enrich **FortiGuard AI-Powered Security Services** with the very latest threat intelligence. These services are integral to providing Fortinet's Secure Networking solution with market-leading security capabilities. These solutions and services work together to provide the best protection for your applications, content, web traffic, devices, and users located anywhere.



SOFTWARE PROJECT MANAGEMENT

Edited by

SIVAGAMI . E



978-93-6255-287-7

SOFTWARE PROJECT MANAGEMENT

Copyright@ 2023 by Sivagami.E

All rights reserved. No part of this book may be reproduced or transmitted in any form or by any means without written permission from the author.

ISBN :978-93-6255-287-7

Publisher: Ponnaiah Ramajayam Institute of Science and Technology[PRIST]

TABLE OF CONTENTS

| | |
|---|----|
| CHAPTER 1: Navigating Software Project Success: A Comprehensive Guide to Planning, Development, and Management. | 1 |
| R. Suganya | |
| CHAPTER 2: "Mastering the Art of Software Project Economics: Cost Estimation, Staffing and Requirements Definition Strategies"..... | 3 |
| K. Vijayabaskar | |
| CHAPTER 3: "Crafting Excellence in Software Design: Concepts, Techniques, and Best Practices for Effective System Development"..... | 5 |
| P. Karthik | |
| CHAPTER 4: "Coding Mastery: Best Practices and Guidelines for Effective Software Implementation | 7 |
| R. Rajayogeswari | |
| CHAPTER 5 : "Ensuring Excellence: A Comprehensive Guide to Software Verification, Validation, and Maintenance Strategies"..... | 9 |
| R. Kalaiselvi | |
| CHAPTER 6: Contract Management and Technical Project Management..... | 11 |
| H. PARVEENBEGAM | |
| CHAPTER 7: Activities Covered by Software Project Management..... | 13 |
| Mrs.Sathyapriya | |
| CHAPTER 8: Plans, Methods and Methodologies..... | 15 |
| K. Priyadharshini | |
| CHAPTER 9: Project Success and Failure..... | 19 |
| G. Gayathri | |
| CHAPTER 10: Traditional versus Modern Project Management Practices..... | 22 |
| R. Banumathi | |

CHAPTER 1

Navigating Software Project Success:

A Comprehensive Guide to Planning, Development, and Management

R. SUGANYA

(Assistant Professor, Department of Computer science, Ponnaiah Ramajayam Institute of Science and Technology[PRIST], Thanjavur.)

Project management is the compass that guides us toward achieving our objectives, whether they are personal aspirations or ambitious business endeavors. It's the discipline that helps us to turn ideas into reality, navigate constraints, and ensure our projects stay on course. In this journey, we'll explore the world of project management, bridging its relevance for both businesses and individuals while unraveling essential concepts like project, project management, and key constraints.



Understanding Projects

A project is essentially a unique endeavor, an expedition with a defined beginning and end, designed to accomplish specific objectives and inevitably usher in change. Whether it's launching a new product, orchestrating a wedding, or embarking on a fitness journey, each of these undertakings constitutes a project, and they all share the common trait of instigating transformation.

Why is Project Management Crucial?

Without good project management, delivering on our customers' requirements becomes uncertain. We might end up with a combination of missed deadlines, budget overruns, or confused teams. These issues can lead to project failure, posing a potential threat to your organization's overall success. On the other hand, effective project management guarantees meticulous planning, vigilant monitoring, and precise task and resource execution, paving the way to successful projects and, in the long run, helping our business grow.

CHAPTER-2

Mastering the Art of Software Project Economics (Cost Estimation, Staffing, and Requirements Definition Strategies)

K. VIJAYABASKAR

(Assistant Professor, Department of Computer science, Ponnaiah Ramajayam Institute of Science and Technology[PRIST], Thanjavur.)

Introduction

Accurate software cost estimation and effective cost management are crucial for the success of any software development project. From startups to multinational corporations, organizations strive to deliver high-quality software solutions within budget and on schedule.

However, achieving this goal requires a deep understanding of software cost estimation techniques, proven strategies, and the right tools. In this comprehensive guide, we will delve into the intricacies of software cost estimation and management, equipping you with the knowledge and resources to navigate the complexities of software project budgets.

Utilizing reliable free estimating software enhances accuracy and streamlines the estimation process.

Understanding Software Cost Estimation

Software cost estimation is the process of predicting the financial resources required to complete a software development project successfully. It involves analyzing various factors, including project scope, requirements, complexity, and resources, to derive accurate cost estimates. Effective cost estimation lays the foundation for budgeting, resource allocation, and project planning, enabling organizations to make informed decisions and mitigate financial risks. **Key Factors Influencing Software Cost Estimation:**

Several **factors influence software development costs**, and understanding these factors is crucial for accurate estimation. Some key factors include:

- **Project Scope:** The complexity and scope of the project significantly impact cost estimation. Projects with extensive requirements and functionalities may require more resources and, consequently, higher costs.
- **Technology Stack:** The choice of technology, programming languages, and frameworks can affect development costs. Advanced technologies or specialized tools may require additional resources and expertise, leading to higher costs.

CHAPTER -3

Crafting Excellence in Software Design

(Concepts, Techniques, and Best Practices for Effective System Development)

P. KARTHIK

(Assistant Professor, Department of Computer science, Ponnaiah Ramajayam Institute of Science and Technology[PRIST], Thanjavur.)

Craftsmanship is timeless, being an integral practice to human history since the dawn of our species. It represents a quality of uniform excellence, often characterized by removing unnecessary elements from a design and bringing out the best in the crafted object. And although craftsmanship is often associated with aesthetic pursuits like painting or sculpture, its importance goes beyond; it serves as a powerful reminder of the value of hard work and skilled ‘hands-on’ effort, a notion that helps us tap into our creativity and realize our ambitions. Mastering craftsmanship, therefore, is not only a source of motivation but also a means to change our current place for the better.

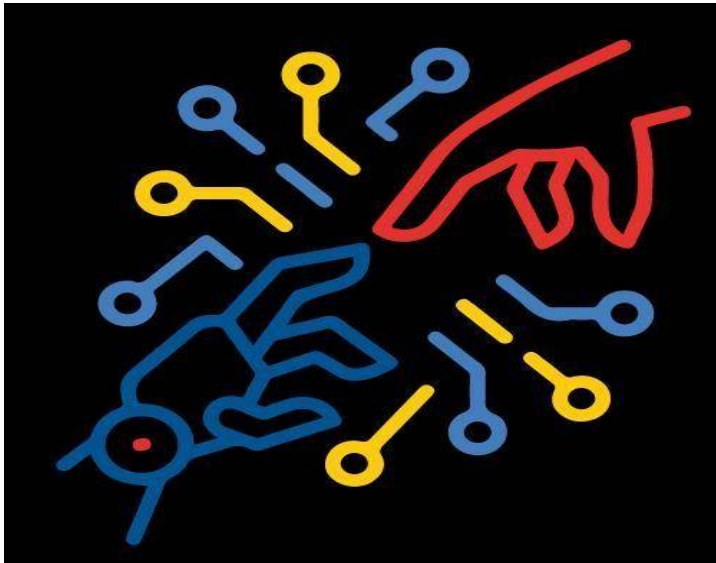

And considering how technology is the biggest agent of change in our world, it might be interesting to find out if the idea of craftsmanship has a place in this modern computer-driven reality. Is there craftsmanship to be found in software development? After all, programming consists of a combination of hard skills, innovative techniques, and a love for constantly perfecting processes that translate into high-quality products. It can be said that developers practice a craftsmanship approach in every project, taking pride in the details and focusing on making changes that have a clear impact on performance, stability, scalability, and many other aspects of development.

However, for most people, it's easy to overlook the art behind software development, but the craftsmanship is present in every little task.

CHAPTER-4

Coding Mastery (Best Practices and Guidelines for Effective Software Implementation)

R. RAJAYOGESWARI

(Assistant Professor, Department of Computer science, Ponnaiah Ramajayam Institute of Science and Technology[PRIST], Thanjavur.)

Writing code is not just about functionality but also about creating maintainable, scalable, and secure applications. Following coding standards and best practices is essential to achieve these goals. They are guidelines that help developers write code that is not only efficient but also consistent, making it easier for teams to collaborate and maintain codebases over time.

The Importance of Coding Standards

Following coding guidelines and conventions contribute to the overall success of a project. Its goal is to promote consistency, readability, collaboration, maintainability, and security, ultimately leading to the delivery of high-quality, reliable software. Below, we will explain in detail what this means.

Consistency

When all developers follow the same set of rules, the code becomes more readable and understandable. Coding standards ensure consistency across a codebase. This is vital for collaboration, especially in larger development teams.

Readability

The readability of code makes it easier for developers to understand the codebase, collaborate with team members, and quickly identify and fix issues. Readable code is essential for long-term maintenance and scalability.

Collaboration

In a collaborative development environment, coding standards act as a common language. When everyone follows the same conventions, it becomes easier to review each other's code, identify issues, and provide constructive feedback. This collaboration fosters a more efficient and effective development process.

CHAPTER -5

Ensuring Excellence: A Comprehensive Guide to Software Verification, Validation, and Maintenance Strategies

R. KALAISELVI

(Assistant Professor, Department of Computer science, Ponnaiah Ramajayam Institute of Science and Technology[PRIST], Thanjavur.)

Introduction

This method is basically developed to assist accredited laboratories in validation of software for calibration and testing.

If the laboratories comply with the requirements they will also meet the requirements of ISO 9001. The goal of this method was also to cover the situation where an accredited laboratory wants to develop and sell validated computer software on commercial basis.

Furthermore, the most rigorous validation requirements come from the medical and pharmaceutical industry. In order to let this method, benefit from the ideas and requirements used in this area, the guidance from U.S. Food and Drug Administration (FDA) “General principles of software validation” and the GAMP Guide are intensively used as inspiration.

This method is not a guideline. It is a tool to be used for systematic and straightforward validation of various types of software. The laboratories may simply choose which elements they want to validate and which they do not. It is their option and their responsibility.

Method of Software Validation

In order to assure consistency, conventional terms used in this document will apply to the following definitions:

- Computer system.

A group of hardware components and associated software designed and assembled to perform a specific function or group of functions

- Software.

A collection of programs, routines, and subroutines that controls the operation of a computer or a computerized system.

CHAPTER-6

Contract Management and Technical Project Management

H. PARVEENBEGAM

(Assistant Professor, Department of Computer science, Ponnaiah Ramajayam Institute of Science and Technology[PRIST], Thanjavur.)

Contract and claim management play an important role in project management: In order to complete projects successfully and economically, laws and contracts must be strictly adhered to. If this is not the case, risks increase, e.g., due to additional demands from the client. In this context, both contract management and claim management are essential to the project. Contract management deals with the design, analysis, conclusion and amendment of contracts, taking into account the links with change and claim management, as well as the monitoring of contract performance. Claim management is the part of project management that manages requirements, change requests or enhancements.

Contracts in externally commissioned projects

The basis for almost all externally commissioned projects is the project contract. Its contents are binding on all parties to the contract. They, and especially the project managers, must know and understand it. Contract management, which is described in detail below, first helps to identify the rights and obligations arising from the contract. This is where the first risks to the project become apparent. Only when your rights are clearly identified and documented is it possible to enforce them. Contract management controls the execution of contracts during the course of the project in such a way that obligations can be precisely fulfilled, and risks minimised.

A prerequisite for effective contract management is that management and the project manager are aware that contracts must be precisely fulfilled. This is the only way to avoid additional demands from the contractual partner and to keep the costs and deadlines of the project under control.

Legal sphere

The law applicable to a project and its facets can be divided into different legal spheres according to their historical origins. The largest of these are the continental European, Anglo-Saxon, Chinese and Islamic legal systems. The legal spheres differ in terms of the establishment of norms, i.e., statutory law, customary law and case law, divine law (based on rules given by God and not on conventions agreed by human beings), etc., but also in terms of the application of law, e.g. the role of a judge.

CHAPTER-7

Activities Covered by Software Project Management.

Mrs.S. SATHYAPRIYA

(Assistant Professor, Department of Computer science, Ponnaiah Ramajayam Institute of Science and Technology[PRIST], Thanjavur.)

Project activities comprise multiple sub-tasks which need to be carried out to complete the entire activity. If you've ever engaged on a management plan, you must be surely familiar with the term "activity." Although it appears evident what project activities are, you should be more thoroughly conscious of their significance in making proposals. A well-designed sequence of efforts might differ from a failure to a successful [Project Management ideas](#). When you create a plan, the contributor will always inquire about the entire project you intend to perform.

The project's services are the steps conducted to accomplish the organization's goal. They are highly specific, realistic, and well-defined procedures. When reading about the objectives, you should be able to visualize them promptly.

Additionally, project activities example assist you in determining your desired outcome. A completed action results in the production of an output. This can also be quite beneficial when discussing indicators, assessments, and well-planned actions that are easily observable. It is also significant that donors frequently adopt a broader approach, while actions may be of key value to work packages.

Project Management Activities List



CHAPTER-8

Plans, Methods and Methodologies

K. PRIYADHARSHINI

(Assistant Professor, Department of Computer science, Ponnaiah Ramajayam Institute of Science and Technology[PRIST], Thanjavur.)

From information technology to marketing, teams operating across a diverse range of industries and disciplines rely on project management methodologies to deliver for their organizations.

While project management methods are widely used, there's no one-size-fits-all solution. Rather, there are dozens of different ways to manage projects. If you want to set the stage for the success of your project while also ensuring that your time and resources are used efficiently, it's vital that you choose the right management framework.

With that in mind, here's an overview of 23 of the best project management methodologies. Armed with this information, you'll be able to identify the approach that best serves your business.

What is a project management methodology?

A project management methodology is a set of tools and guidelines that help you organize projects in a way that optimizes efficiency and performance.

More specifically, a given project management method helps you more easily manage a project by providing a repeatable series of steps and principles. The goal of any framework is to promote collaboration, increase operational efficiency, keep the project on budget, and enhance the quality of the final deliverable.

While there are many [methodologies within project management](#), the following are some of the most well-known.

1. Waterfall methodology

Alternatively referred to as the software development life cycle (SDLC), the Waterfall method is a linear approach to project management. In this methodology, each phase of work “cascades” into the next.

CHAPTER-9

Project Success and Failure

G. GAYATHRI

(Assistant Professor, Department of Computer science, Ponnaiah Ramajayam Institute of Science and Technology[PRIST], Thanjavur.)

The success of a project is the result of many different decisions, people, tasks, communications, and unseen elements that affect the work of everyone involved.

Understanding the most common factors in project success, as well as what will likely lead to failure, will have positive impacts on your professional services organization.

The following examples of project management success factors will help you gain a better understanding of how effective project managers plan, communicate, manage risk, and successfully close projects.



Critical Success Factor Examples in Project Management

CSFs are activities that adhere to a high standard of quality, help you meet your project goals, and help you prioritize your tasks to meet your projected goals.

When implemented correctly, CSFs make it clear which steps your team needs to tackle first, and what they should pay close attention to. They also allow for better collaboration between team members.

CHAPTER-10

Traditional versus Modern Project Management Practices.

R. BANUMATHI

(Assistant Professor, Department of Computer science, Ponnaiah Ramajayam Institute of Science and Technology[PRIST], Thanjavur.)

Traditional Project Management:

In the world of project portfolio management (PPM), the Agile framework seems to reign supreme. But before there was Agile, Scrum, or any other modern project management approach, there were traditional practices that helped organizations structure and schedule their project life cycles. These methods, often lumped into the umbrella term “traditional project management,” still have plenty of relevance and utility today. Whether they’re the most efficient choice for your PPM team depends on your goals and needs.

What is Traditional Project Management, Exactly?

While there’s no official definition of “traditional” project management, the term most commonly refers to pre-Agile methods and approaches to PPM. It might also be used interchangeably with the most common approach to traditional project management, the Waterfall methodology.

Generally speaking, traditional project management focuses on a step-by-step approach to planning a project’s life cycle. It may or may not utilize a certain framework (though it often does not) to manage tasks and goals. While traditional methods may be falling out of practice, tried-and-true options like Waterfall and the critical path method definitely still have a lot to offer to project organizations and leaders.

4 Popular Traditional Project Management Methods

Exploring some of the key characteristics of the project planning routines of the past helps us better understand how to organize our own workflows, no matter what that looks like. Traditional project management might include one or more of the following practices or methodologies.

1. Waterfall

Best for: Large projects and organizations that require a structured approach to planning and execution.

VIRTUAL REALITY

Edited by

S.SUGANYA



978-93-6255-856-5

Virtual Reality
Copyright © 2023 by S. SUGANYA

All rights reserved. No part of this book may be reproduced or transmitted in any form or by any means without written permission from the author.

ISBN: 978-93-6255-856-5

Publisher: PonnaIyah Ramajayam Institute of Science and Technology
(PRIST)

TABLE OF CONTENTS

| | |
|--|---|
| CHAPTER 1: Tracing the Three I's of VR | 1 |
| S. Suganya | |
| CHAPTER 2: Unveiling the Essence of VR Technology: | 2 |
| M. Aarthi | |
| CHAPTER 3: Essentials of Augmented Reality | 3 |
| D.S. Chozhabharathi | |
| CHAPTER 4 VR Software and Tools | 4 |
| G. Gayathri | |
| CHAPTER 5: Crafting VR Experiences | 5 |
| S. Suganya | |
| CHAPTER 6: Future of Virtual Reality | 6 |
| J. Mangai Nila | |
| CHAPTER 7: VR Hardware and Equipment | 7 |
| S. Satya priya | |

CHAPTER 1

TRACING THE THREE I'S OF VR

S. Suganya

Assistant Professor Department of Computer Science
Ponnaiyah Ramajayam Institute of Science
and Technology, Tamil Nadu, India

In this chapter, we will explore the foundational elements of Virtual Reality (VR) that are often referred to as the "Three I's": Immersion, Interaction, and Imagination. These three components are crucial for creating compelling and effective VR experiences. We will examine each of these elements in detail, discussing their significance and how they contribute to the overall impact of VR.

Immersion refers to the sensation of being enveloped in a virtual environment, feeling as if one is physically present within that space. This deep sense of presence is what differentiates VR from traditional media experiences.

Immersion can vary across different VR experiences. For instance, simple simulations may provide limited immersion, while fully immersive environments that engage multiple senses (sight, sound, touch) can create a profound sense of presence.

High levels of immersion can lead to greater engagement, emotional responses, and even changes in behavior. Users may experience empathy in storytelling scenarios or improved retention in educational contexts due to the engaging nature of the immersive experience.

Interaction refers to how users engage with and manipulate the virtual environment. It is a vital component that transforms passive experiences into active participation.

Direct Interaction: Users manipulate virtual objects using hand gestures or controllers. This includes actions like picking up items, pushing buttons, or navigating menus.

Indirect Interaction: Involves using interface elements like menus and sliders, allowing users to influence the environment without direct manipulation.

Social Interaction: Multi-user environments enable collaboration and communication, enhancing engagement and creating a shared experience

In the following chapters, we will delve into practical applications of VR, explore advanced technologies, and examine case studies that illustrate the successful implementation of the Three I's in various domains.

CHAPTER 2

UNVEILING THE ESSENCE OF VR TECHNOLOGY

M. Aarthi

Assistant Professor Department of Computer Science
Ponnaiyah Ramajayam Institute of Science
and Technology, Tamil Nadu, India

In this chapter, we explore the fundamental principles and technologies that underpin Virtual Reality (VR). Understanding these core elements will provide a foundation for appreciating how VR works and its potential applications across various fields. We will discuss the hardware, software, and key technologies that make VR experiences possible, as well as the challenges and future directions of VR technology.

VR Headsets: The primary device that delivers immersive experiences, equipped with displays, lenses, and sensors. Examples include Oculus Rift, HTC Vive, and PlayStation VR.

Tracking Systems: Essential for determining the user's position and movement within the virtual space. Common tracking methods include:

Inside-Out Tracking: Uses cameras on the headset to map the environment.

Outside-In Tracking: Relies on external sensors placed in the room.

Controllers and Input Devices: Allow users to interact with the virtual environment through hand gestures, buttons, and touchpads. Examples include motion controllers, gloves, and even treadmills for full-body interaction.

VR Headsets: The primary device that delivers immersive experiences, equipped with displays, lenses, and sensors. Examples include Oculus Rift, HTC Vive, and PlayStation VR.

Tracking Systems: Essential for determining the user's position and movement within the virtual space. Common tracking methods include:

Inside-Out Tracking: Uses cameras on the headset to map the environment.

Outside-In Tracking: Relies on external sensors placed in the room.

In this chapter, we unveiled the essence of VR technology by examining its core components, key technologies, and the challenges faced in its development and application. Understanding these fundamentals is crucial for grasping the potential of VR and its transformative impact across various domains.

CHAPTER 3

ESSENTIALS OF AUGMENTED REALITY

D.S. Chozhabharathi

Assistant Professor Department of Computer Science
Ponnaiyah Ramajayam Institute of Science
and Technology, Tamil Nadu, India

In this chapter, we explore the core concepts, technologies, and applications of Augmented Reality (AR). Unlike Virtual Reality (VR), which immerses users in a completely virtual environment, AR enhances the real world by overlaying digital information, images, or objects. This chapter aims to provide a comprehensive understanding of AR's fundamental elements and its potential impact across various industries.

Augmented Reality (AR) is a technology that overlays digital content onto the real world, allowing users to interact with both physical and digital elements simultaneously. This integration enriches the user's perception of their environment.

Types of Augmented Reality

Marker-Based AR: Uses visual markers (like QR codes) to trigger digital content when scanned by a device's camera.

Marker less AR: Utilizes GPS, compass, and accelerometer data to provide AR experiences without the need for specific markers. Common in mobile applications.

Projection-Based AR: Projects digital images onto physical surfaces, enabling interaction through gestures.

Superimposition-Based AR: Replaces or augments the view of an object with a digital counterpart, often used in applications like virtual furniture placement.

Device Compatibility: Ensuring that AR applications work seamlessly across various devices and operating systems can be challenging.

In this chapter, we explored the essentials of Augmented Reality, including its definitions, types, technologies, and applications across various sectors. AR enhances our interaction with the real world, offering innovative solutions that can transform industries and improve user experiences.

CHAPTER 4

VR SOFTWARE AND TOOLS

G. Gayathri

Assistant Professor Department of Computer Science
Ponnaiyah Ramajayam Institute of Science
and Technology, Tamil Nadu, India

In this chapter, we will explore the various software and tools essential for developing Virtual Reality (VR) experiences. Understanding these tools is crucial for creators, as they facilitate the design, development, and deployment of immersive VR content. We'll discuss game engines, development platforms, asset creation tools, and collaboration software that are commonly used in the VR development process.

Game Engines

Overview: A widely used game engine for developing 2D and 3D content, Unity offers a robust environment for VR development.

Key Features:

Cross-Platform Support: Allows deployment on multiple VR platforms, including Oculus, HTC Vive, and PlayStation VR.

Asset Store: A rich marketplace for purchasing and sharing assets, plugins, and tools.

C# Programming: Uses C# as the primary scripting language, making it accessible for many developers.

In this chapter, we explored the essential software and tools required for VR development, including game engines, development platforms, asset creation tools, and collaboration software. Each tool plays a critical role in the VR development process, helping creators bring their visions to life.

As we continue through this book, we will dive deeper into specific applications of these tools, explore case studies showcasing their successful implementation, and discuss best practices for efficient VR development.

In this chapter, we explored the essential software and tools required for VR development, including game engines, development platforms, asset creation tools, and collaboration software. Each tool plays a critical role in the VR development process, helping creators bring their visions to life.

CHAPTER 5

CRAFTING VR EXPERIENCES

S. Suganya

Assistant Professor Department of Computer Science
Ponnaiyah Ramajayam Institute of Science
and Technology, Tamil Nadu, India

In this chapter, we explore the process of creating engaging and immersive Virtual Reality (VR) experiences. Crafting effective VR experiences involves a combination of storytelling, design principles, technical skills, and an understanding of user interactions. This chapter will guide you through the key components, methodologies, and best practices for developing VR content that captivates and engages users.

Designing VR Experiences

Narrative Structure: Develop a compelling story that guides users through the experience. Consider nonlinear storytelling to allow for exploration and discovery.

Character Development: Create relatable characters that users can connect with emotionally, enhancing engagement.

Visual Fidelity: High-quality graphics and realistic environments.

Spatial Audio: 3D sound that enhances realism and spatial awareness.

Haptic Feedback: Physical sensations that provide tactile responses to interactions.

Environment Design

3D Modeling:

Asset Creation: Develop or source 3D models, textures, and animations.

Environmental Details: Focus on lighting, weather effects, and interactive elements.

Spatial Layout: Design the physical space to support user movement and interactions.

Each of these components is essential for crafting an effective VR experience. Understanding how they interconnect will enable developers to create immersive, engaging, and user-centric VR content. As we progress through this book, we will explore practical examples and case studies that demonstrate the successful application of these components in real-world VR experiences.

CHAPTER 6

FUTURE OF VIRTUAL REALITY

J. Mangai Nila

Assistant Professor Department of Computer Science
Ponnaiyah Ramajayam Institute of Science
and Technology, Tamil Nadu, India

In this chapter, we explore the emerging trends, technologies, and potential applications of Virtual Reality (VR) as it continues to evolve. Understanding the future of VR will provide insights into how this technology can transform various industries, enhance user experiences, and integrate with other technological advancements.

Technological Advancements

Next-Gen VR Headsets: Future headsets will likely feature improved resolution, wider field of view, and lighter designs for increased comfort and immersion.

Wireless Technology: Advancements in wireless technology, such as 5G, will reduce latency and enhance streaming capabilities, allowing for more complex and interactive experiences.

Cultural Experiences: VR has the potential to revolutionize how we experience culture, allowing users to explore art, history, and heritage in immersive ways.

Remote Collaboration: As remote work becomes more common, VR can facilitate virtual meetings and collaboration, enhancing team dynamics and productivity.

Eye Tracking: Future VR systems may incorporate eye-tracking technology to create more intuitive interactions and improve realism in rendering by focusing resources on what the user is looking at.

Hand Tracking: Improved hand-tracking capabilities will allow for more natural interactions without the need for controllers, enhancing immersion.

In this chapter, we explored the future of Virtual Reality, focusing on technological advancements, integration with other technologies, expanding applications, and the challenges ahead. As VR continues to evolve, its potential to transform industries and enhance user experiences will only grow.

As we move forward in this book, we will look at case studies of innovative VR applications, examine successful implementations across various sectors, and discuss strategies for leveraging VR technology to create meaningful and impactful experiences.

CHAPTER 7

VR HARDWARE AND EQUIPMENT

S. Satya priya

Assistant Professor Department of Computer Science
Ponnaiyah Ramajayam Institute of Science
and Technology, Tamil Nadu, India

In this chapter, we explore the various hardware and equipment essential for creating and experiencing Virtual Reality (VR). Understanding the different components that make up a VR system is crucial for developers and users alike, as they impact the quality, immersion, and usability of VR experiences.

Tethered Headsets:

Overview: These headsets are connected to a powerful PC or console, providing high-quality graphics and processing power.

Examples: Oculus Rift, HTC Vive, Valve Index.

Key Features: Superior graphics, extensive tracking capabilities, and access to a wide range of high-end VR games and applications.

Standalone Headsets:

Overview: These headsets are self-contained and do not require an external PC or console, making them more portable and user-friendly.

Examples: Oculus Quest 2, Pico Neo.

Key Features: Wireless operation, built-in processing, and storage, suitable for casual users and developers alike.

Overview: This tracking method uses cameras and sensors on the headset to detect the user's position and movement within the environment.

Benefits: Easier setup, as it does not require external sensors; often found in standalone headsets like the Oculus Quest. Accessories. Each component plays a vital role in delivering immersive and engaging VR experiences.

As we continue through this book, we will explore how to select the appropriate hardware for specific applications, best practices for setup and configuration, and the future of VR hardware advancements that promise to enhance the user experience even further.

NATURAL LANGUAGE PROCESSING

EDITED BY
S.PRIYA



978-93-6255-853-4

NATURAL LANGUAGE PROCESSING

Copyright © 2023 by S. PRIYA

All rights reserved. No part of this book may be reproduced or transmitted in any form or by any means without written permission from the author.

ISBN: 978-93-6255-853-4

Publisher: PonnaIyah Ramajayam Institute of Science and Technology
(PRIST)

TABLE OF CONTENTS

| | |
|---|----|
| CHAPTER 1 Unlocking the Essence of NLP..... | 1 |
| R. SUGANYA | |
| CHAPTER 2 Decoding Linguistic Structures..... | 2 |
| K. VIJAYABASKAR | |
| CHAPTER 3 Navigating Meaning | 3 |
| G. GAYATHRI | |
| CHAPTER 4 Building Bridges in Language | 4 |
| R. RAJAYOGESWARI | |
| CHAPTER 5 Beyond the Search Bar | 5 |
| P. SAKILA | |
| CHAPTER 6 Integration of Word-Level Analysis with Parsing | 6 |
| K. PRIYADHARSHINI | |
| CHAPTER 7 Future Directions in NLP Linguistic Analysis | 7 |
| S. SATHYA PRIYA | |
| CHAPTER 8 Syntactic Parsing Techniques | 8 |
| P. SAKILA | |
| CHAPTER 9 Evaluating Parsing Accuracy | 9 |
| G. GAYATHRI | |
| CHAPTER 10 Frameworks for NLP Structure..... | 10 |
| K. VIJAYABASKAR | |

CHAPTER 1

Unlocking the Essence of NLP

R. SUGANYA

Assistant Professor Department of Computer Science
Ponnaiyah Ramajayam Institute of Science
and Technology, Tamil Nadu, India

This chapter aims to familiarize students with the concept of NLP and this chapter introduces the basics about the NATURAL LANGUAGE PROCESSING.

Natural language processing (NLP) is a machine learning technology that gives computers the ability to interpret, manipulate, and comprehend human language.

Natural Language Processing (NLP) is one of the most important techniques in computer science and it is a key part of many exciting applications such as AI and chatbots. There are 4 different types of techniques: Statistical Techniques, Stochastic Techniques, Rule-Based Techniques and Hybrid Techniques.

Key Features of NLP

Common NLP Tasks & Techniques

- Tokenization. ...
- Part-of-speech tagging. ...
- Dependency Parsing. ...
- Constituency Parsing. ...
- Lemmatization & Stemming. ...
- Stop word Removal. ...
- Word Sense Disambiguation. ...
- Named Entity Recognition (NER)

1. Text Processing and Preprocessing in NLP

Tokenization: Dividing text into smaller units, such as words or sentences.

Stemming and Lemmatization: Reducing words to their base or root forms.

Stop word Removal: Removing common words (like “and”, “the”, “is”) that may not carry

Text Normalization: Standardizing text, including case normalization, removing punctuation,

2. Syntax and Parsing in NLP

Part-of-Speech (POS) Tagging: Assigning parts of speech to each word in a sentence (e.g., noun, verb, adjective).

Dependency Parsing: Analyzing the grammatical structure of a sentence to identify relationships between words.

CHAPTER 2 DECODING LINGUISTIC STRUCTURES

K. VIJAYABASKAR

Assistant Professor Department of CS

Ponnaiyah Ramajayam Institute of Science

and Technology, Tamil Nadu, India

1 Word-Level Analysis

Tokenization: The process of breaking text into individual words or tokens. This is crucial for many NLP tasks.

Morphology: Study of the structure of words, including prefixes, suffixes, and root words. Understanding morphological rules helps in better tokenization and analysis.

Part-of-Speech Tagging: Assigning parts of speech (nouns, verbs, adjectives, etc.) to each token, which is vital for syntactic and semantic understanding.

2. Regular Expressions

Definition: A sequence of characters that form a search pattern. Regular expressions are powerful tools for text processing and manipulation.

Applications: Used for tasks like extracting phone numbers, emails, or specific patterns from text, as well as for data validation.

Syntax: Basic components include literals, meta-characters (e.g., *, +, .), and character classes.

Mastery of regex syntax enhances the ability to filter and analyse textual data efficiently.

3. Syntactic Parsing

Definition: The process of analysing a sentence to understand its grammatical structure.

Types of Parsing:

Constituency Parsing: Breaks sentences into sub-phrases or constituents. Each constituent is a tree structure representing the hierarchical nature of sentences.

Dependency Parsing: Focuses on the relationships between words, identifying which words modify or depend on others.

Algorithms: Common algorithms include Shift-Reduce parsing, Early parsing, and more. Understanding these can help in implementing parsing techniques effectively.

4. Integration for NLP Mastery

Combining Techniques: Effective NLP systems often integrate word-level analysis, regular expressions, and syntactic parsing to improve understanding and processing of natural language.

CHAPTER 3 NAVIGATING MEANING

G. GAYATHRI

Assistant Professor Department of CS

Ponnaiyah Ramajayam Institute of Science

and Technology, Tamil Nadu, India

1. Semantic Analysis

This part focuses on understanding the meaning of words, phrases, and sentences in context. It may include:

Conceptual Representation: How meaning is structured and represented in the mind or computationally.

Word Sense Disambiguation: Techniques for determining which meaning of a word is used in a given context.

Thematic Roles: Understanding the roles that different entities play in a sentence (e.g., agent, patient).

2. Lexical Semantics

This section would delve into the relationship between words and their meanings. Key topics might include:

Word Meaning and Relations: Exploring synonyms, antonyms, hyponyms, and hypernyms.

Frame Semantics: The idea that words evoke certain mental frameworks or scenarios.

Polysemy and Homonymy: Discussing words with multiple meanings and how context helps clarify which meaning is intended.

3. Discourse Processing

Discourse processing looks at how sentences connect and how meaning is constructed across larger texts. Important aspects might include:

Cohesion and Coherence: Mechanisms that link sentences together and create a logical flow in text.

Reference Resolution: Techniques for determining what nouns or pronouns refer to in discourse.

Pragmatics: Understanding implied meanings, context, and speaker intentions beyond literal interpretations.

Enhanced Natural Language Understanding

The chapter likely concludes by tying these areas together to illustrate how they contribute to improved natural language understanding systems. It may discuss:

Integration of Techniques: How combining semantic analysis, lexical semantics, and discourse processing enhances machine understanding of language.

Applications: Real-world applications in chatbots, virtual assistants, and information retrieval systems.

CHAPTER 4 BUILDING BRIDGES IN LANGUAGE

R. RAJAYOGESWARI

Assistant Professor Department of CS
Ponnaiyah Ramajayam Institute of Science
and Technology, Tamil Nadu, India

This chapter explores the fundamental aspects of Natural Language Generation (NLG) systems, their architecture, applications, and challenges, particularly in the context of machine translation (MT) with a focus on Indian languages. Here's a breakdown of the key areas the chapter likely covers:

The chapter might also cover how technology—such as language learning apps, real-time translation tools, and AI-powered communication—has revolutionized the way people learn and use languages. These advances are creating more bridges, making it easier for people to connect regardless of their native language.

The chapter could address the benefits of bilingualism or multilingualism. It might explore how knowing multiple languages enables individuals to access different cultures and communities, thus building more bridges across linguistic and cultural divides.

Another important theme could be the challenge of language barriers and how they can create divides. The chapter might discuss methods for overcoming these barriers, such as learning new languages, using translation tools, or adopting simplified communication techniques. This is often referred to as "building bridges" in the sense of making communication possible despite differences.

Finally, the chapter could delve into the emotional and psychological aspects of language, highlighting how words can build empathy, understanding, and trust. The ability to communicate effectively in another's language can deepen relationships and break down prejudices or misunderstandings.

Machine Translation (MT) Overview

Definition: The process of converting text from one language to another using algorithms and models.

Types of MT:

Rule-Based: Based on linguistic rules and dictionaries.

Statistical: Uses statistical models trained on large corpora.

Neural MT: Utilizes deep learning techniques to improve fluency and accuracy.

Challenges in Machine Translation

Linguistic Diversity: Indian languages have diverse grammatical structures, scripts, and idioms.

Resource Scarcity: Many Indian languages lack sufficient training data and linguistic resources.

Cultural Nuances: Capturing the cultural context and idiomatic expressions can be challenging.

CHAPTER 5 BEYOND THE SEARCH BAR

P. SAKILA

Assistant Professor Department of CS

Ponnaiyah Ramajayam Institute of Science

and Technology, Tamil Nadu, India

The chapter "**Beyond the Search Bar: Design Features, Models, and Lexical Resources in Information Retrieval Systems with a Glimpse into Semantic Analysis**" explores the various aspects that go beyond basic keyword search in modern Information Retrieval (IR) systems, delving into design features, models, and the role of lexical and semantic resources.

1. Design Features in Information Retrieval Systems (IRS)

User Interface Design: Focus on how modern IRS are designed to provide a seamless user experience. This may include suggestions, predictive search, and personalized search results. User interface features such as **auto-completion**, **search filters**, and **faceted search** are now common, improving efficiency and user satisfaction.

Relevance Feedback Mechanisms: In many advanced systems, the user's actions (clicking, skipping, etc.) are used as feedback to refine the search algorithm and improve the relevance of future search results.

Personalization & Contextualization: IRS often adapt based on the user's history, preferences, and contextual information such as location, search history, or device being used.

2. Models in Information Retrieval

Boolean Model: One of the oldest models, based on set theory, where documents are retrieved based on exact matching of query terms.

Vector Space Model: A more flexible model where documents and queries are represented as vectors in a multi-dimensional space, allowing for partial matching and ranking based on similarity measures such as **cosine similarity**.

Probabilistic Models: These involve predicting the probability that a given document will be relevant to the query. **BM25** is a well-known example of this model, widely used in modern search engines.

3. Lexical Resources

Thesauri and Synonyms: The use of lexical databases like **WordNet** to expand queries by adding related terms (synonyms, hypernyms, etc.), enhancing recall by fetching documents that may not contain the exact keywords.

Named Entity Recognition (NER): Identifying specific entities (e.g., names of people, places, organizations) within text to improve precision and offer relevant results.

Stop words and Stemming/Lemmatization: Lexical pre-processing steps that help in normalizing text. For example, stemming reduces words to their root form (e.g., "running" to "run"), and stop words like "the" or "is" are removed to focus on important terms.

CHAPTER 6 INTEGRATION OF WORD-LEVEL ANALYSIS WITH PARSING

K. PRIYADHARSHINI

Assistant Professor Department of CS
Ponnaiyah Ramajayam Institute of Science
and Technology, Tamil Nadu, India

The chapter titled "**Integration of Word-Level Analysis with Parsing**" most likely discusses how word-level linguistic analysis is integrated with syntactic parsing to enhance natural language understanding in various computational systems, particularly in natural language processing (NLP) and information retrieval (IR) systems. The goal is to move beyond isolated word analysis and use syntactic structures to derive more meaningful insights from language.

Word-Level Analysis (Morphology)

Morphological analysis deals with the structure of words and how they can be broken down into morphemes (the smallest units of meaning). This process includes identifying:

Stems: The core meaning of a word.

Affixes: Prefixes and suffixes that modify the meaning or function.

Inflections: Modifications to words to express different grammatical categories like tense, case, gender, etc.

Syntactic Parsing

Parsing involves analysing sentence structure to identify how words relate to each other in phrases and clauses. This is crucial for tasks such as:

Dependency parsing: Understanding which words depend on others (subject-verb-object).

Constituency parsing: Identifying hierarchical structure in sentences (nouns, verbs, and their related phrases).

Integration of Morphological and Syntactic Insights

Morph-syntactic Alignment: Integration involves ensuring that morphological information (word structure) feeds into syntactic parsing. For example, identifying the tense or number of a verb helps in syntactic parsing by determining subject-verb agreement.

Handling Complex Structures: Some languages have complex morphology (e.g., Finnish, Turkish), where morphological analysis provides critical insights to help syntactic parsers understand sentence structure correctly.

Ambiguity Resolution: By combining morphological and syntactic analysis, systems can better resolve ambiguities, such as when a word has multiple possible interpretations depending on context.

CHAPTER 7

FUTURE DIRECTIONS IN NLP LINGUISTIC ANALYSIS

S. SATHYA PRIYA

Assistant Professor Department of CS
Ponnaiyah Ramajayam Institute of Science
and Technology, Tamil Nadu, India

The chapter titled "**Future Directions in NLP Linguistic Analysis**" likely explores emerging trends, technologies, and research areas that are shaping the future of natural language processing (NLP) with a focus on linguistic analysis. Here's a breakdown of the key themes and concepts that may be covered

Writing analytics uses computational techniques to analyse written texts for the purposes of improving learning. This chapter provides an introduction to writing analytics, through the discussion of linguistic and domain orientations to the analysis of writing, and descriptive and evaluative intentions for the analytics. The chapter highlights the importance of the relationship between writing analytics and good pedagogy, contending that for writing analytics to positively impact learning, action ability must be considered in the design process. Limitations of writing analytics are also discussed, highlighting areas of concern for future research. Keywords: Writing Analytics, natural language processing, NLP, linguistics, pedagogy, feedback

ORIENTATION TO ANALYSIS OF WRITING Writing is a complex activity involving skillful management of cognitive, social, and affective processes [18, 24]. A writing artefact not only includes information about the subject of writing, but also incorporates information about the writer's skill in writing, stylistic characteristics of their writing, and can at times reveal information about how the writer thinks about the subject, as well as personal information about themselves. The analysis of writing precedes the use of computational tools [20], and WA has been extensively influenced by non-computational approaches to analysis. Fundamentally, analysis tends to be approached from a mixture of two orientations, one from a linguistic standpoint and another that comes from a domain standpoint

Improved Contextual Understanding

Contextualized Word Embedding's: The importance of using embedding's that take context into account, allowing for better disambiguation of words and phrases based on their usage in sentences.

Long-Context Models: Discussion of models that can maintain context over longer passages of text, improving coherence in tasks like summarization and conversation.

4. Incorporating Pragmatics and Discourse Analysis

Understanding Intent and Implicate: Future NLP may need to incorporate pragmatic aspects of language, focusing on how context influences meaning beyond the literal interpretation.

Discourse Coherence: Research might focus on how to build systems that understand and generate text that is coherent and contextually appropriate over longer stretches of discourse.

5. Ethics and Fairness in NLP

Bias Mitigation: Exploring methods to identify and reduce biases in NLP models, ensuring that language technologies are fair and inclusive across different demographics and languages.

Ethical Considerations: Discussing the ethical implications of NLP technologies, including privacy concerns, misinformation, and the impact of automated systems on society.

CHAPTER 8

SYNTACTIC PARSING TECHNIQUES

P. SAKILA

Assistant Professor Department of CS
Ponnaiyah Ramajayam Institute of Science
and Technology, Tamil Nadu, India

A **chapter** refers to a division within a book, document, or other written work. It organizes content into sections, making it easier to read and understand. Each chapter typically focuses on a specific topic, theme, or aspect of the overall subject matter of the book. Here's a breakdown of what a chapter usually

1. Structure and Organization

Chapters provide a way to structure the book into smaller, manageable parts, each dealing with a particular idea or section of the narrative.

For example, in a novel, each chapter may focus on a different scene or event, while in a textbook, each chapter could cover a specific concept or theory.

2. Topic or Theme

Chapters are often organized around a central topic or theme. In nonfiction works, each chapter typically explores a different aspect of the subject. In fiction, chapters might focus on different characters, settings, or plot developments.

3. Titles and Headings

Many chapters begin with a title or heading that reflects the content of that section. This helps readers understand what the chapter will cover and gives an overview of the focus.

4. Progression of Ideas

Chapters often build upon each other. The earlier chapters lay the foundation for concepts or narratives, while later chapters expand or conclude them. In educational texts, chapters are usually ordered to guide the reader from basic to more advanced ideas.

5. Breaks in the Narrative

Chapters create natural breaks in the narrative, giving readers an opportunity to pause. In storytelling, these breaks might also build suspense or signal a change in setting or time.

CHAPTER 9

EVALUATING PARSING ACCURACY

G. GAYATHRI

Assistant Professor Department of CS
Ponnaiyah Ramajayam Institute of Science
and Technology, Tamil Nadu, India

The chapter titled "**Evaluating Parsing Accuracy**" likely focuses on how the performance of syntactic parsers—tools that analyze the grammatical structure of sentences—is measured and assessed. This is crucial in computational linguistics and natural language processing (NLP) to ensure that parsers produce reliable and accurate results. Here's a detailed explanation of what this chapter might include:

Parsing Accuracy refers to how correctly a syntactic parser identifies the grammatical structure of a sentence. The chapter would likely start by explaining the significance of accurate parsing in various applications like machine translation, speech recognition, and text processing.

It would emphasize why evaluating the accuracy of parsers is critical for improving NLP systems and ensuring they can understand and process human language effectively.

Precision: This measures how many of the predicted syntactic relations or structures (like phrase boundaries or dependencies) are correct. It's the proportion of true positives among all positive predictions.

Recall: This indicates how many of the actual syntactic relations or structures in the sentence are correctly identified by the parser. It's the proportion of true positives among all actual positive instances.

F1 Score: The chapter might introduce the **F1 Score** as a combination of precision and recall, used to provide a balanced evaluation of parsing accuracy. The F1 score gives a single value that captures both precision and recall in cases where they may trade off against each other.

Exact Match Accuracy: This metric evaluates whether the entire predicted parse tree matches the correct tree exactly. It's a more stringent measure that checks for full correctness, not just partial correctness.

The chapter would emphasize the importance of using high-quality, well-annotated corpora, such as the **Penn Treebank** or **Universal Dependencies**, for evaluating parser performance.

These provide the "ground truth" for comparison.

It might also explain how different languages or domains require specialized corpora for accurate evaluation

CHAPTER 10

FRAMEWORKS FOR NLP STRUCTURE

K. VIJAYABASKAR

Assistant Professor Department of CS
Ponnaiyah Ramajayam Institute of Science
and Technology, Tamil Nadu, India

The chapter titled "**Frameworks for NLP Structure**" would likely focus on the different tools, libraries, and frameworks used in natural language processing (NLP) to handle various linguistic tasks like text analysis, syntactic parsing, machine translation, and more. These frameworks provide ready-made components and methodologies that help in building efficient NLP applications. Here's a breakdown of what this chapter might cover:

the chapter would begin by introducing **NLP frameworks** as software libraries or tools that simplify the development of applications that process and understand human language. It would explain that these frameworks include pre-built modules for tokenization, part-of-speech tagging, named entity recognition (NER), syntactic parsing, machine translation, and more.

Preprocessing Capabilities: Most NLP frameworks provide tools for cleaning and preparing text data. This includes tokenization, stop word removal, stemming, and lemmatization.

Linguistic Analyzers: Frameworks often include pre-trained models for tasks like part-of-speech tagging, syntactic parsing, and semantic role labeling.

Data Handling: Frameworks come with utilities to handle different types of data, including text, structured data, and corpora.

Customizability and Extensibility: Some frameworks allow users to build custom models or integrate external machine learning models for domain-specific tasks

Developed by Stanford University, this toolkit offers a comprehensive set of linguistic features, including dependency parsing, sentiment analysis, and reference resolution.

It's often praised for its accuracy in syntactic and semantic analysis, making it popular in academic research.

Built on top of Pytorch, AllenNLP is designed for deep learning models in NLP. It offers tools for building custom NLP models, especially those based on transformer architectures like BERT and GPT.

The chapter might explain how AllenNLP is often used for state-of-the-art research in natural language understanding (NLU).



ENTERPRISE RESOURCE PLANNING

EDITED BY

J.MANGAI NILA



978-93-6255-784-9

Enterprise Resource Planning
Copyright © 2023 by J. MANGAI NILA

All rights reserved. No part of this book may be reproduced or transmitted in any form or by any means without written permission from the author.

ISBN: 978-93-6255-704-9

Publisher: PonnaIyah Ramajayam Institute of Science and Technology
(PRIST)

TABLE OF CONTENTS

| | |
|---|----|
| CHAPTER 1: ERP Foundations..... | 1 |
| P. karthik | |
| CHAPTER 2: ERP Architecture and Technology..... | 2 |
| R. Kalaiselvi | |
| CHAPTER 3: ERP Implementation and Configuration..... | 3 |
| S. Sathya priya | |
| CHAPTER 4: ERP Tiers and Vendor Landscape..... | 4 |
| R. Rajayogeswari | |
| CHAPTER 5: ERP Future Directions and Emerging Trends..... | 5 |
| P. Sakila | |
| CHAPTER 6: ERP Financial management..... | 6 |
| M. Aarthi | |
| CHAPTER 7: ERP Industry-specification..... | 7 |
| D.S. Chozhabharathi | |
| CHAPTER 8: ERP Life cycle..... | 8 |
| K. Vijayabaskar | |
| CHAPTER 9: ERP Operational Modules..... | 9 |
| G. Gayathri | |
| CHAPTER 10: ERP Analytics and Reporting Modules..... | 10 |
| M. Aarthi | |

CHAPTER 1: ERP Foundations

R. RAJAYOGESWARI

Assistant Professor Department of Computer Science

Ponnaiyah Ramajayam Institute of Science

and Technology, Tamil Nadu, India

This chapter focuses on the implementation and configuration of Enterprise Resource Planning (ERP) systems, covering the steps involved in planning, executing, and deploying an ERP system.

This section covers the process of transferring data from legacy systems to the new ERP system, including data cleansing, mapping, and testing.

The chapter highlights the importance of thorough testing, including unit testing, integration testing, and user acceptance testing, to ensure the ERP system meets business requirements.

Benefits:

- **Improved Efficiency:** Streamlined business processes and automated workflows
- **Enhanced Decision-Making:** Real-time data and analytics for informed decision-making
- **Increased Accuracy:** Reduced errors and improved data quality
- **Better Collaboration:** Integrated system for improved communication and collaboration
- **Scalability:** ERP system can adapt to growing business needs
- **Cost Savings:** Reduced costs through automated processes and improved resource allocation
- **Improved Customer Satisfaction:** Enhanced customer service through improved order management and fulfilment
- **Competitive Advantage:** ERP system provides a platform for innovation and growth.

The chapter would start by explaining what **ERP** is: a type of software that integrates various business functions, such as finance, human resources, procurement, supply chain management, and more, into a single system.

It would highlight that ERP systems centralize data, allowing different departments to access and share information in real-time, improving efficiency and decision-making across the organization.

CHAPTER 2: ERP ARCHITECTURE AND TECHNOLOGY

R. KALAISELVI

Assistant Professor Department of Computer Science

Ponnaiyah Ramajayam Institute of Science

and Technology, Tamil Nadu, India

The chapter titled "**ERP Architecture and Technology**" would focus on the underlying structure and technological foundations that enable Enterprise Resource Planning (ERP) systems to function. This chapter would explore how ERP systems are designed, the components that make up their architecture, and the technologies that support their implementation and operation. Here's a detailed explanation of what the chapter might cover:

The chapter would begin by explaining the concept of **ERP architecture**: the structural design of the ERP system that determines how its various components interact with each other and with the organization's processes.

ERP architecture is crucial because it ensures the system's scalability, flexibility, and ability to integrate with other business systems and technologies.

Types of ERP Architecture

This section would delve into the different types of ERP architecture models that have evolved over time:

Monolithic Architecture (Legacy ERP Systems):

Traditional ERP systems followed a **monolithic architecture**, where all modules (finance, HR, inventory, etc.) were tightly integrated into one system. While this ensures a single source of truth, it often makes the system rigid, difficult to customize, and challenging to upgrade.

the chapter would then explore the major components that make up ERP architecture:

Database: The central repository for all business data. ERP systems use relational databases (e.g., Oracle, SQL Server, MySQL) to store structured data. In some cases, ERP systems may also support **NoSQL** databases for handling large volumes of unstructured data.

Business Logic Layer: This is the core of the ERP system where all business rules and processes are executed. It governs how data is processed, how transactions are handled, and how workflows are managed.

User Interface (UI): The front-end interface that users interact with. Modern ERP systems focus on delivering intuitive, user-friendly interfaces that simplify interactions for end-users.

Integration Middleware: Many ERP systems require integration with external systems (e.g., CRM, e-commerce platforms, or third-party apps). Middleware enables seamless communication between different systems through **APIs** and **web services**.

Reporting and Analytics Tools: ERP systems often include **business intelligence (BI)** and analytics capabilities to provide real-time reports, dashboards, and insights into business operations.

CHAPTER 3: ERP Implementation and Configuration

S. Sathya priya

Assistant Professor Department of Computer Science

Ponnaiyah Ramajayam Institute of Science

and Technology, Tamil Nadu, India

The chapter titled "**ERP Implementation and Configuration**" would focus on the practical aspects of deploying an Enterprise Resource Planning (ERP) system within an organization, covering the processes, challenges, and best practices for a successful ERP implementation. It would also delve into how an ERP system is configured to meet the specific needs of a business. Here's a would likely be included in this

The chapter would begin by defining **ERP implementation** as the process of selecting, planning, deploying, and integrating an ERP system within an organization to manage its business processes.

The goal of ERP implementation is to ensure that the ERP system aligns with the organization's strategic objectives and improves operational efficiency.

In this phase, a detailed blueprint or roadmap is created to align the ERP system's design with the company's business processes.

Business Process Mapping: The company defines how its current processes will be integrated into the new ERP system.

Customization Requirements: The ERP system may require customization to meet the unique needs of the business, such as modifying workflows, adding new functionalities, or integrating third-party applications.

Challenges and Risks in ERP Implementation

Implementing an ERP system is a complex process with several risks and challenges. This section would outline common challenges, along with strategies for mitigating them:

Data Migration Issues: One of the biggest challenges is migrating data from legacy systems to the new ERP system. Ensuring data accuracy and avoiding data loss are critical.

Resistance to Change: Employees may resist adopting the new system, particularly if they are used to working with legacy systems. Proper change management and training are essential to overcome this.

Cost Overruns and Delays: ERP implementation projects often run over budget and behind schedule due to unforeseen complexities or inadequate planning.

Customization Challenges: Over-customizing an ERP system can lead to long-term maintenance difficulties and complicate future upgrades. Businesses need to balance customization with standardization.

Integration with Legacy Systems: Ensuring that the new ERP system can effectively integrate with existing software and systems can be technically challenging.

CHAPTER 4: ERP TIERS AND VENDOR LANDSCAPE

R. Rajayogeswari

Assistant Professor Department of Computer Science

Ponnaiyah Ramajayam Institute of Science

and Technology, Tamil Nadu, India

The chapter titled "**ERP Tiers and Vendor Landscape**" would provide an overview of the different levels (tiers) of ERP systems and explore the various vendors that supply ERP solutions, categorized by their target market and capabilities. It would help businesses understand the ERP ecosystem, the types of solutions available, and how to choose the right ERP system based on organizational size, industry needs, and business complexity. Here's a detailed breakdown of what this chapter might cover:

The chapter would introduce the different tiers of ERP systems, typically divided into **three main levels**:

a. Tier 1 ERP Systems

Target Audience: Large enterprises, multinational corporations, and organizations with complex, global operations.

Features and Capabilities:

- Comprehensive, feature-rich systems that cover every aspect of business processes, from finance and human resources to supply chain management and customer relationship management.
- Highly customizable and scalable to handle massive amounts of data and complex business processes.
- Multi-language, multi-currency, and multi-company support, along with compliance with different international regulations and tax laws.
- Advanced analytics, business intelligence (BI), and reporting tools.
- Integration with other enterprise applications, third-party software, and technologies such as AI, IoT, and block chain.

Challenges:

- Tier 1 ERP systems are often expensive, requiring significant investment in both implementation and ongoing maintenance.
- Implementation times can be long, and these systems are complex to configure and manage.

Examples of Tier 1 ERP Vendors:

- **SAP**
- **Oracle ERP Cloud**
- **Microsoft Dynamics 365**
- **Inform**

b. Tier 2 ERP Systems

Target Audience: Medium-sized businesses or large businesses that operate on a more regional or national scale.

Features and Capabilities:

- While offering many of the same core functionalities as Tier 1 systems (finance, supply chain, HR, etc.), Tier 2 ERPs are less complex and often more specialized for specific industries or regions.
- These systems are more affordable and faster to implement than Tier 1 systems.
- Moderate customization and integration options, though not as robust as Tier 1 ERPs.
- They often focus on supporting fewer global operations, limited to specific regions or countries.

CHAPTER 5: ERP FUTURE DIRECTIONS AND EMERGING TRENDS

P. Sakila

Assistant Professor Department of Computer Science

Ponnaiyah Ramajayam Institute of Science

and Technology, Tamil Nadu, India

The chapter titled "**ERP Future Directions and Emerging Trends**" would explore the evolving landscape of Enterprise Resource Planning (ERP) systems, highlighting the latest advancements in technology and how ERP systems are adapting to meet the demands of modern businesses. The chapter would cover the impact of new technologies, shifting business models, and changing market dynamics on ERP systems, offering insights into how businesses can stay competitive by leveraging these trends.

This section would provide an overview of how ERP systems have evolved over time, from their origins as basic financial and manufacturing tools to comprehensive platforms that integrate various business processes.

It would emphasize the increasing importance of **cloud computing**, **mobile access**, and **integration with advanced technologies** in driving the next generation of ERP solutions.

A discussion on why traditional ERP systems are transforming and how emerging trends are shaping the future of ERP.

This section would cover how **AI** and **machine learning** are being integrated into ERP systems to enhance functionality and automate processes:

Predictive Analytics: AI-powered ERP systems can analyze historical data to make predictions about future trends, such as demand forecasting, inventory management, and financial planning.

Automated Decision-Making: AI helps ERP systems automatically make decisions or provide recommendations, such as optimizing procurement strategies or identifying process inefficiencies.

Natural Language Processing (NLP): AI-driven ERP systems with NLP capabilities can interpret and respond to human language, making it easier for users to interact with the system through voice commands or Chabot's.

Robotic Process Automation (RPA): RPA can automate repetitive tasks, such as data entry, invoice processing, and report generation, reducing manual workloads.

This section would discuss the integration of **IoT** technologies with ERP systems to provide real-time data from physical devices and sensors.

IoT-ERP Integration Benefits:

Supply Chain Optimization: IoT devices can track inventory levels, shipments, and equipment performance in real-time, allowing businesses to automate supply chain processes and reduce costs.

Predictive Maintenance: IoT-enabled sensors can monitor machinery and equipment, sending data to the ERP system to predict maintenance needs and prevent downtime.

Improved Decision-Making: IoT data integrated into ERP systems can provide real-time insights into business operations, enabling more informed decision-making.

With the growing need for **mobile-first** solutions, ERP vendors are developing **mobile ERP applications** that allow employees to access ERP functionalities from smartphones and tablets.

CHAPTER 6: ERP FINANCIAL MANAGEMENT

M. Aarthi

Assistant Professor Department of Computer Science

Ponnaiyah Ramajayam Institute of Science

and Technology, Tamil Nadu, India

The chapter titled "**ERP Financial Management**" would focus on how Enterprise Resource Planning (ERP) systems handle financial processes within an organization. This chapter is likely to explain the key components and capabilities of financial management modules in ERP systems, including accounting, budgeting, forecasting, financial reporting, and compliance. It would highlight how these systems provide a centralized platform for managing financial data, ensuring accuracy, and improving decision-making.

This section would outline the key financial management modules typically found in ERP systems and their functions:

General Ledger (GL)

Function: The GL serves as the central repository for all financial transactions, recording debits and credits and summarizing them into balance sheets and income statements.

Key Features:

Real-time financial tracking across all business units.

Multi-dimensional chart of accounts to manage financial data by department, product line, or geography.

Support for multiple currencies and compliance with international accounting standards (GAAP, IFRS).

Function: Manages the company's liabilities and outgoing payments, tracking all purchases and payments to vendors.

Key Features:

Automated invoice processing and approval workflows.

Supplier management and payment scheduling.

Integration with purchasing and procurement modules for seamless processing.

Accounts Receivable (AR)

Function: Manages incoming payments and ensures that customers are billed correctly and payments are collected on time.

Key Features:

Customer invoicing and credit management.

Cash receipts tracking and collections automation.

Integration with sales modules for accurate invoicing.

This section would explain how ERP financial management integrates seamlessly with other ERP

CHAPTER 7: ERP INDUSTRY-SPECIFICATION

D.S. Chozhabharathi

Assistant Professor Department of Computer Science

Ponnaiyah Ramajayam Institute of Science

and Technology, Tamil Nadu, India

The chapter titled "**ERP Industry-Specific Solutions**" would focus on how Enterprise Resource Planning (ERP) systems are tailored to meet the unique needs of different industries. While ERP systems provide core functionalities such as financial management, procurement, inventory management, and human resources, industry-specific ERP solutions are designed to address the specialized requirements of particular sectors like manufacturing, healthcare, retail, construction, and more. These tailored solutions incorporate features that help companies in each industry manage their specific processes more effectively.

This section would highlight how ERP systems cater to **manufacturing**, one of the most ERP-intensive industries, covering both **discrete** and **process manufacturing**:

Features Specific to Manufacturing ERP:

Bill of Materials (BOM) Management: Tracks the list of materials and components required to produce a product.

Production Planning and Scheduling: Helps manage production schedules, resource allocation, and capacity planning to ensure efficient manufacturing processes.

Shop Floor Control: Monitors and manages work-in-progress (WIP), machine performance, and labor productivity.

Quality Control: Tracks product quality, ensuring that goods meet industry standards and customer specifications.

Supply Chain Integration: Manages the flow of materials and products, from procurement of raw materials to the delivery of finished goods.

This section would discuss how ERP systems are designed for **retailers** and **e-commerce** companies, focusing on managing large volumes of inventory and customer interactions.

Key Features of Retail ERP:

Inventory and Stock Management: Helps retailers manage large product inventories across multiple locations, including real-time stock level monitoring and automated reordering.

Point of Sale (POS) Integration: Combines sales data from physical stores and e-commerce platforms into one system for accurate tracking.

Omni channel Support: ERP systems for retail provide integrated support for **Omni channel** operations, ensuring seamless interaction between online, mobile, and in-store sales.

Customer Relationship Management (CRM): Tracks customer behavior, preferences, and purchase history to improve customer service and marketing efforts.

Demand Forecasting and Analytics: Uses historical sales data and trends to forecast demand and optimize inventory.

Loyalty Programs: Manages and tracks customer loyalty programs to incentivize repeat purchases.

CHAPTER 8: ERP LIFE CYCLE

K. Vijayabaskar

Assistant Professor Department of Computer Science

Ponnaiyah Ramajayam Institute of Science

and Technology, Tamil Nadu, India

The chapter titled "**ERP Life Cycle**" would explain the various stages involved in the successful implementation and management of an Enterprise Resource Planning (ERP) system within an organization. The ERP life cycle provides a structured approach to planning, implementing, and maintaining ERP systems, ensuring that organizations can optimize their processes and meet their business goals.

This initial phase focuses on understanding the need for an ERP system and determining the organization's requirements.

Key Activities:

Identifying Business Needs: The organization assesses its current business processes, inefficiencies, and future goals.

Feasibility Study: Evaluating whether an ERP system will be a cost-effective solution for addressing the company's challenges.

Budget Planning: Setting a budget that accounts for software, hardware, consultancy, training, and implementation costs.

Forming a Project Team: Assembling a cross-functional team consisting of key stakeholders (IT, finance, operations) who will oversee the project.

Setting Objectives and Scope: Defining clear objectives for what the ERP system must achieve, such as process optimization, cost reduction, or improved reporting.

Change Management Preparation: Identifying potential resistance to change and developing a strategy to manage the transition.

In this phase, the organization evaluates and selects the appropriate ERP software and vendor that best fits its business needs.

Key Activities:

Requirement Analysis: Identifying detailed functional and technical requirements based on business processes (e.g., financials, HR, supply chain).

Vendor Evaluation: Researching and evaluating different ERP vendors (e.g., SAP, Oracle, Microsoft Dynamics) based on factors like industry fit, features, cost, and scalability.

Demos and Proof of Concept (PoC): Vendors typically provide demonstrations of their software to showcase its features, and some may offer a PoC to validate how the system fits into the organization's workflows.

Decision Making: The project team and stakeholders select the best ERP solution and vendor based on their evaluations.

CHAPTER 9: ERP OPERATIONAL MODULES

G. Gayathri

Assistant Professor Department of Computer Science

Ponnaiyah Ramajayam Institute of Science

and Technology, Tamil Nadu, India

The chapter titled "**ERP Operational Modules**" focuses on the various functional components or modules of an Enterprise Resource Planning (ERP) system that manage and streamline the core operations of an organization. ERP systems are divided into different operational modules, each addressing a specific business function. These modules are integrated into a unified system, allowing data to flow seamlessly across departments and enabling organizations to optimize processes, improve efficiency, and make better business decisions.

ERP systems typically include several **core modules** that are crucial for the day-to-day operations of most businesses. Each module focuses on a specific operational area, helping organizations manage various functions seamlessly.

General Ledger (GL): Manages all financial transactions, including debits and credits, and generates financial reports such as profit & loss and balance sheets.

Accounts Payable (AP): Tracks payments to vendors and suppliers, manages invoices, and ensures timely payments.

Accounts Receivable (AR): Manages incoming payments from customers and tracks outstanding invoices.

Asset Management: Manages company assets, including depreciation, maintenance, and disposal of physical and intangible assets.

Tax Management: Handles tax calculation and ensures compliance with tax regulations in different regions.

Financial Reporting: Generates real-time reports and insights into the financial health of the organization. The **HR module** manages all employee-related activities, from recruitment to payroll processing, while ensuring compliance with labor laws.

Key Features:

Employee Data Management: Stores personal information, job roles, and employment history of employees.

Recruitment and Onboarding: Manages job postings, applicant tracking, and new employee onboarding processes.

Payroll Management: Calculates salaries, taxes, deductions, and benefits, and processes payments to employees.

Time and Attendance: Tracks employee attendance, leaves, overtime, and shift schedules.

Performance Management: Tracks employee performance, appraisals, and promotions.

CHAPTER 10: ERP Analytics and Reporting Modules

M. Aarthi

Assistant Professor Department of Computer Science

Ponnaiyah Ramajayam Institute of Science

and Technology, Tamil Nadu, India

Data Integration Across Modules

ERP systems collect data from multiple departments, including finance, HR, procurement, and production. The analytics and reporting module integrates this data to provide a holistic view of the organization.

Key Benefit:

Data from different departments can be analyzed together, helping businesses make informed decisions based on a complete picture.

Dashboards and Visualization Tools

Dashboards provide users with a visual representation of key business metrics in real-time. They offer graphs, charts, and tables that make it easier to interpret data.

Key Features:

Customizable Dashboards: Users can customize dashboards to display the metrics most relevant to their role (e.g., a CFO may focus on financial health, while a supply chain manager may focus on inventory levels).

Real-Time Data: Dashboards update in real-time, ensuring that decision-makers always have access to the most current data.

Interactive Visuals: Allows users to drill down into specific data points for more detailed analysis.

Importance: Visualization tools make complex data more accessible and easier to understand, allowing for faster decision-making.

Standard and Custom Reports

The module provides both pre-built standard reports and the ability to create custom reports tailored to specific business needs.

Standard Reports:

These reports are designed to provide a broad overview of common business processes, such as financial statements, sales performance, and inventory levels.

Examples: Profit & loss reports, balance sheets, sales reports, and production reports.

Custom Reports:

Users can create custom reports by selecting specific data fields, filtering criteria, and display formats. This flexibility allows businesses to generate reports tailored to their unique requirements.

Importance: Custom reports enable companies to focus on specific KPIs (key performance indicators) or metrics that are crucial to their business strategy.



WEB DEVELOPMENT

Edited by

J.MANGAI NILA



978-93-6255-731-5

Web Development

Copyright © 2023 by J. MANGAI NILA

All rights reserved. No part of this book may be reproduced or transmitted in any form or by any means without written permission from the author.

ISBN: 978-93-6255-731-5

Publisher: PonnaIyah Ramajayam Institute of Science and Technology
(PRIST)

TABLE OF CONTENTS

| | |
|--|---|
| CHAPTER 1: PHP Installation with a Glimpse into Dynamic Website..... | 1 |
| J. Mangai Nila | |
| CHAPTER 2: Mastering PHP Syntax: | 2 |
| M. Aarthi | |
| CHAPTER 3: PHP Sessions and Cookies..... | 3 |
| D.S. Chozhabharathi | |
| CHAPTER 4: Efficiency Action in PHP | 4 |
| G. Gayathri | |
| CHAPTER 5: Testing and Debugging in web development..... | 5 |
| K. Vijayabaskar | |
| CHAPTER 6: Unlocking PHP's Potential | 6 |
| J. Mangai Nila | |
| CHAPTER 7:AI and Machine Learning in web development..... | 7 |
| S. Satya priya | |

CHAPTER 1

PHP INSTALLATION WITH A GLIMPSE INTO DYNAMIC

J. Mangai Nila

Assistant Professor Department of Computer Science

Ponnaiyah Ramajayam Institute of Science

and Technology, Tamil Nadu, India

In this chapter, we introduce PHP, a widely-used, open-source server-side scripting language designed specifically for web development. Here, you'll gain an understanding of what PHP is, how it works, and why it's crucial for building dynamic websites.

Overview of PHP:

PHP, which stands for Hypertext Preprocessor, is an open-source, server-side scripting language designed primarily for web development. PHP is widely known for its simplicity, versatility, and efficiency in creating dynamic and interactive websites. It integrates smoothly with HTML, enabling web developers to embed PHP scripts within HTML code to execute various server-side functions, such as form handling, database operations, and session management.

Ease of Learning: PHP's syntax is simple and beginner-friendly, making it accessible for new programmers. **Open Source:** PHP is free to use, supported by a vast community of developers who contribute to its ongoing development.

Cross-Platform Compatibility: PHP runs on various operating systems such as Windows, Linux, and macOS, making it highly flexible. **Rich Ecosystem:** It has extensive support for databases (like MySQL, PostgreSQL), and a wide range of frameworks (like Laravel, Symfony) that make development faster and more efficient.

Dynamic web development refers to websites that respond to user actions, pull data from databases, and adapt their content without requiring page reloads. PHP, combined with HTML, CSS, and JavaScript, plays a key role in this process.

phpinfo () Function:

- Use the `phpinfo()` function to check the PHP configuration, version, and enabled extensions.
- This function outputs a detailed overview of the PHP environment.

CHAPTER 2

MASTERING PHP SYNTAX

M. Aarthi

Assistant Professor Department of Computer Science
Ponnaiyah Ramajayam Institute of Science
and Technology, Tamil Nadu, India

In this chapter, we will dive deep into the core syntax of PHP, which forms the foundation for writing efficient and readable code. Understanding PHP syntax is crucial for creating dynamic web pages, managing data, and building complex web applications.

Basic Structure of PHP Code

PHP code is embedded within HTML and is enclosed within special tags:

```
<? php  
  
    // PHP code goes here  
  
?>
```

HP tags tell the server where the PHP code starts and ends, distinguishing it from HTML.

Key Points:

- PHP code must be enclosed in `<? php?>` tags.
- PHP files typically have a `.php` extension.
- PHP statements end with a semicolon.

Introduction to PHP Security:

Why Security Matters: Understanding the potential risks of insecure PHP code and how vulnerabilities can compromise data, user privacy, and website functionality. **Common PHP Security Threats:** An overview of common attack vectors, including SQL injection, cross-site scripting(XSS), cross-site request forgery (CSRF), and remote file inclusion (RFI).

Using Prepared Statements and Parameterized Queries: Always use PDO or MySQL with prepared statements to prevent SQL injection.

Escaping User Input: Avoid directly including user input in SQL queries; sanitize inputs with proper escaping functions. **Avoiding Dynamic SQL:** Do not construct SQL queries dynamically from user input unless fully validated.

CHAPTER 3

PHP SESSIONS AND COOKIES

D.S. Chozhabharathi

Assistant Professor Department of Computer Science
Ponnaiyah Ramajayam Institute of Science
and Technology, Tamil Nadu, India

In this chapter, we will explore how PHP handles user sessions and cookies, two essential concepts for maintaining state and managing user data across multiple pages. Understanding sessions and cookies is crucial for creating dynamic and personalized web applications.

A session is a way to store information (in variables) to be used across multiple pages. Unlike cookies, session data is stored on the server, which provides better security and allows for larger amounts of data to be stored.

How Sessions Work:

Session Start: When a user first accesses a PHP page, a session is created with a unique session ID.

Data Storage: You can store data in the session using the `$_SESSION` super global array.

Session End: The session can end when the user logs out or closes the browser, or it can expire after a set period of inactivity.

A cookie is a small piece of data stored on the client-side (in the user's browser) that can hold user specific information. Cookies are used to remember user preferences, login sessions, and other data.

How Cookies Work:

Set a Cookie: The server sends a cookie to the browser using the `set cookie ()` function.

Cookie Storage: The cookie is stored on the client's machine and sent back to the server with each subsequent request.

Cookie Expiration: Cookies can have expiration dates; after which they will be deleted by the browser.
Security: Use HTTPS to prevent cookie theft.

Regenerate session IDs after login to prevent session hijacking. Avoid storing sensitive information directly in cookies.

CHAPTER 4

EFFICIENCY ACTION IN PHP

G. Gayathri

Assistant Professor Department of Computer Science
Ponnaiyah Ramajayam Institute of Science
and Technology, Tamil Nadu, India

In this chapter, we will focus on best practices and techniques for writing efficient PHP code. Efficiency is critical not only for performance but also for maintaining clean, manageable, and scalable code. We'll cover various aspects, including code optimization, memory management, and best practices for enhancing performance.

PHP has a rich set of built-in functions that are highly optimized. Whenever possible, prefer using these functions over writing custom solutions. For example, use `array_map()` instead of a `for each` loop for transforming arrays.

Optimize Database Queries

Efficiently interacting with databases is crucial for performance:

- Use **prepared statements** to enhance performance and security.
- Index your database tables properly to speed up search queries.
- Fetch only the necessary data using `SELECT` statements.

Caching Strategies

Implement caching strategies to reduce the load on your server and speed up responses:

- **File Caching:** Store HTML outputs or database results in files.
- **Apace:** Use Apace for caching variables in memory.
- **Redis/Me cached:** Use these for more complex caching solutions.

Profiling and Debugging

Use Profiling Tools

Utilize profiling tools like **Debug** or **Backfire** to identify bottlenecks in your code. These tools provide insights into execution time and memory usage.

Debugging Techniques

Make use of `var_dump()`, `print_r()`, and `error_log()` to debug and monitor performance. Establish logging mechanisms to keep track of execution times and errors.

CHAPTER 5

TESTING AND DEBUGGING IN WEB DEVELOPMENT

K. Vijayabaskar

Assistant Professor Department of Computer Science
Ponnaiyah Ramajayam Institute of Science
and Technology, Tamil Nadu, India

In this chapter, we will explore the essential concepts of testing and debugging in web development. Both are critical to ensuring that your web applications function correctly, are user-friendly, and maintain high performance. We'll cover various testing methodologies, debugging techniques, and tools that can enhance your development process.

Unit Testing

- **Definition:** Tests individual components or functions of the application in isolation.
- **Purpose:** To verify that each unit of code behaves as expected.
- **Tools:** PHP Unit for PHP, Jest for JavaScript.

Integration Testing

- **Definition:** Tests the interactions between different components or systems.
- **Purpose:** To ensure that combined components work together correctly.
- **Tools:** Deception, Beat.

Functional Testing

- **Definition:** Tests the application against functional requirements.
- **Purpose:** To verify that the system behaves according to specified use cases.
- **Tools:** Selenium, Cypress.

User Acceptance Testing (UAT)

- **Definition:** Conducted by end-users to validate the application before deployment.
- **Purpose:** To ensure the application meets user expectations and requirements.

In this chapter, you learned the significance of testing and debugging in web development, the different types of testing methodologies, debugging techniques, and tools available for effective troubleshooting. Emphasizing testing and debugging in your development process ensures a higher quality product, leading to better user satisfaction and easier maintenance.

CHAPTER 6

UNLOCKING PHP'S POTENTIAL

J. Mangai Nila

Assistant Professor Department of Computer Science
Ponnaiyah Ramajayam Institute of Science
and Technology, Tamil Nadu, India

In this chapter, we will explore the advanced features and capabilities of PHP that can enhance your web development projects. By understanding these features, you can leverage PHP to create robust, efficient, and scalable applications. We'll cover object-oriented programming, design patterns, frameworks, and integration with other technologies.

Frameworks provide a structured way to build applications, offering tools and libraries that facilitate rapid development, code organization, and adherence to best practices.

Popular PHP Frameworks

Laravel: A robust framework known for its elegant syntax, built-in ORM (Eloquent), and powerful features like routing and middleware.

Symfony: A highly flexible framework that provides reusable components and a set of best practices for web application development.

Code Igniter: A lightweight framework that is easy to set up and has a small footprint, ideal for small to medium-sized applications.

Object-Oriented Programming (OOP)

Core Concepts: Encapsulation, inheritance, polymorphism.

Classes and Objects: Use classes to create objects with properties and methods.

Inheritance: Allows a class to inherit features from another class.

Polymorphism: Enables methods to behave differently based on the object type.

In this chapter, we unlocked the potential of PHP by exploring advanced features such as object-oriented programming, design patterns, popular frameworks, and integration with other technologies. By mastering these aspects, you can create more efficient, scalable, and maintainable web applications.

CHAPTER 7

AI AND MACHINE LEARNING IN WEB DEVELOPMENT

S. Satya priya

Assistant Professor Department of Computer Science
Ponnaiyah Ramajayam Institute of Science
and Technology, Tamil Nadu, India

In this chapter, we will explore how artificial intelligence (AI) and machine learning (ML) can be integrated into web development to enhance user experience, optimize processes, and provide innovative solutions. We'll discuss various applications, tools, and frameworks that facilitate the incorporation of AI and ML in web applications.

AI refers to the simulation of human intelligence processes by machines, particularly computer systems. These processes include learning, reasoning, problem-solving, and understanding natural language.

What is Machine Learning?

A subset of AI that enables systems to learn from data, identify patterns, and make decisions with minimal human intervention.

Types of Machine Learning:

Supervised Learning: The model is trained on labeled data.

Unsupervised Learning: The model works with unlabeled data to find hidden patterns.

Reinforcement Learning: The model learns by receiving rewards or penalties for actions.

Popular Libraries and Frameworks

Tensor Flow: An open-source library for dataflow and machine learning, widely used for deep learning applications.

Koras: A user-friendly API for building neural networks, typically used with Tensor Flow.

Porch: A flexible machine learning library favored for research and production in deep learning.

JavaScript Libraries

In this chapter, we discussed the integration of AI and machine learning into web development, highlighting their applications, tools, and frameworks. By leveraging AI and ML, developers can create more personalized, efficient, and user-friendly web applications.

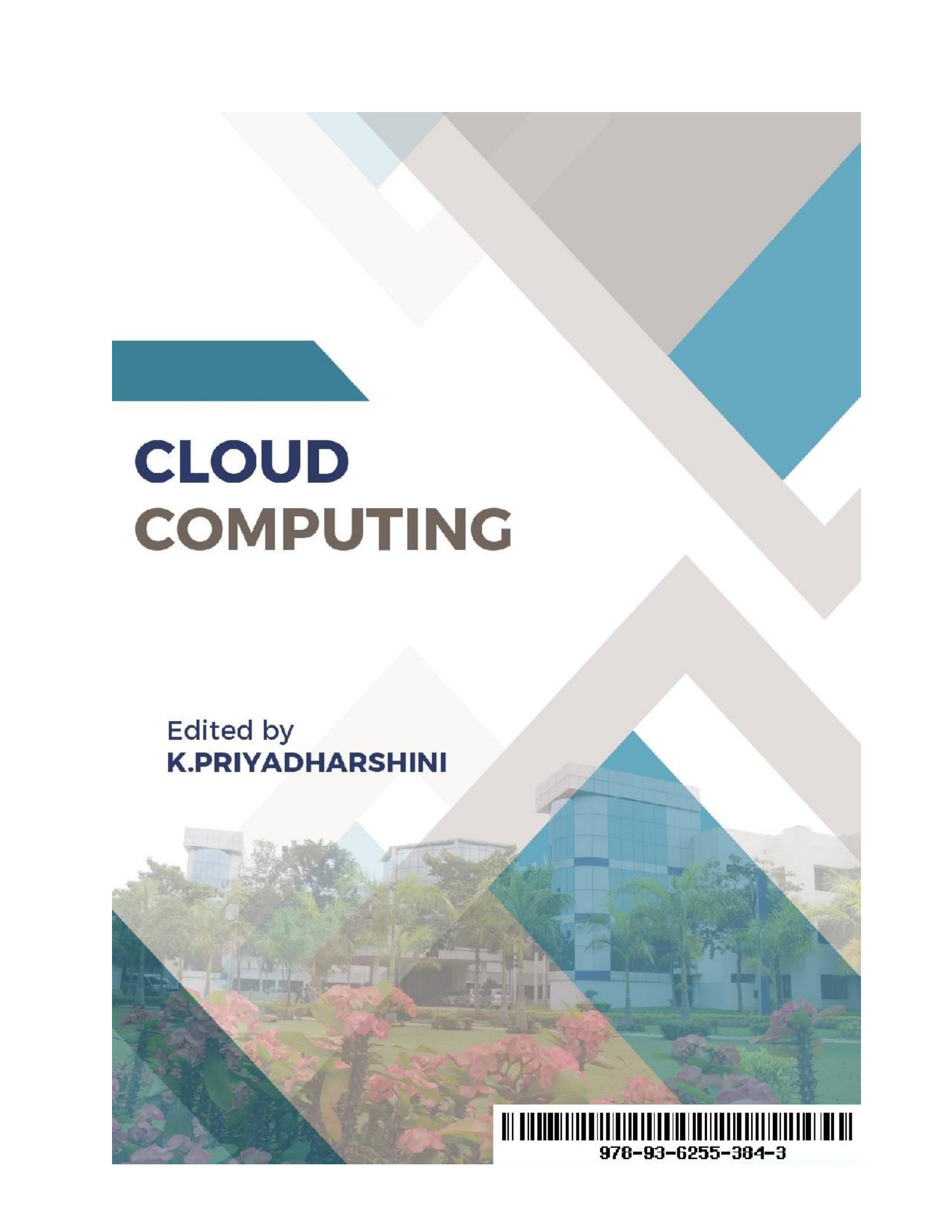

CLOUD COMPUTING

Edited by
K.PRIYADHARSHINI



978-93-6255-384-3

Cloud Computing
Copyright © 2023 by K. PRIYADHARSHINI

All rights reserved. No part of this book may be reproduced or transmitted in any form or by any means without written permission from the author.

ISBN: 978-93-6255-384-3

Publisher: PonnaIyah Ramajayam Institute of Science and Technology
(PRIST)

TABLE OF CONTENTS

| | |
|---|---|
| CHAPTER 1: Cloud Unveiled | 1 |
| M. Aarthi | |
| CHAPTER2: Cloud-Based Collaboration Tools: | 2 |
| P. Sakila | |
| CHAPTER 3: Big Data Analytics in the Cloud | 3 |
| D.S. Chozhabharathi | |
| CHAPTER 4 Cloud Networking: Connectivity and Security | 4 |
| G. Gayathri | |
| CHAPTER 5: Machine Learning and AI in the Cloud | 5 |
| S. Suganya | |
| CHAPTER 6: Identity and Access Management in the Cloud..... | 6 |
| R. Rajayogeswari | |
| CHAPTER 7: Cloud-Based Block Chain Applications | 7 |
| S. Satya priya | |

CHAPTER 1 CLOUD UNVEILED

M. Aarthi

Assistant Professor Department of Computer Science
Ponnaiyah Ramajayam Institute of Science
and Technology, Tamil Nadu, India

In this chapter, **Cloud Unveiled**, we will explore the fundamental concepts behind cloud computing, demystify the technology, and provide a clear understanding of how it works. The chapter covers what cloud computing is, its underlying technologies, benefits, and how it has transformed the way businesses and individuals access and use computing resources.

In the digital age, technology evolves at an unprecedented pace. One of the most transformative innovations of the 21st century is cloud computing. Cloud Unveiled lifts the veil on this revolutionary technology, revealing its inner workings, benefits, and impact on modern computing. Cloud computing is a model for delivering computing services over the internet. It enables on-demand access to a shared pool of computing resources, such as servers, storage, applications, and services.

The concept of cloud computing dates back to the 1960s. However, it wasn't until the early 2000s that cloud computing began to take shape. Amazon Web Services (AWS) launched in 2002, followed by Google Cloud Platform (2009) and Microsoft Azure (2010).

Key Characteristics

Cloud computing is defined by five essential characteristics:

1. On-demand self-service
2. Broad network access
3. Resource pooling
4. Rapid elasticity
5. Measured service

Challenges and Concerns

Despite its benefits, cloud computing raises important questions:

1. Data security and privacy
2. Dependence on internet connectivity
3. Vendor lock-in
4. Regulatory compliance

Cloud Unveiled has provided a comprehensive introduction to cloud computing. As we explore the subsequent chapters, we'll delve deeper into the intricacies of cloud infrastructure, applications, security, and emerging trends.

CHAPTER 2 CLOUD-BASED COLLABORATION TOOLS

P. Sakila

Assistant Professor Department of Computer Science

Ponnaiyah Ramajayam Institute of Science

and Technology, Tamil Nadu, India

This chapter dives into **Cloud-Based Collaboration Tools**, focusing on how cloud technologies have transformed the way individuals and organizations collaborate, manage tasks, and share information. Cloud-based collaboration tools enable real-time communication, document sharing, and project management, fostering greater productivity and flexibility in today's digital workplace.

Effective collaboration is crucial for success in today's fast-paced, globally distributed work environment. Cloud-based collaboration tools have revolutionized the way teams work together, enabling seamless communication, information sharing, and task management. This chapter explores the benefits, features, and best practices of cloud-based collaboration tools.

Benefits of Cloud-Based Collaboration Tools

Cloud-based collaboration tools offer numerous advantages:

1. Increased flexibility and mobility
2. Real-time communication and feedback
3. Enhanced productivity and efficiency
4. Improved data security and backup
5. Scalability and cost-effectiveness

Real-Time Collaboration:

Teams can work simultaneously on documents, presentations, and spreadsheets, seeing updates in real-time, which reduces the need for back-and-forth emails and version confusion.

Remote Accessibility:

Cloud-based tools make it easy for team members to access files, participate in discussions, and collaborate from any location, making remote work more efficient.

In this chapter, we've explored the growing importance of cloud-based collaboration tools in today's work environment. These tools enable organizations to work more efficiently, whether it's through real-time document editing, project management, or team communication. As technology continues to evolve, these tools will become even more integral to how we collaborate, share information, and drive productivity.

Cloud-based collaboration tools have transformed the way teams work together. By understanding the benefits, features, and best practices of these tools, organizations can unlock unprecedented levels of productivity, innovation, and success.

CHAPTER 3 BIG DATA ANALYTICS IN THE CLOUD

D.S. Chozhabharathi

Assistant Professor Department of Computer Science
Ponnaiyah Ramajayam Institute of Science
and Technology, Tamil Nadu, India

This chapter, **Big Data Analytics in the Cloud**, explores the intersection of cloud computing and big data, focusing on how the cloud provides a scalable, cost-effective, and efficient platform for processing and analyzing vast amounts of data. We'll cover the key concepts, tools, and techniques used in cloud-based big data analytics, along with the advantages and challenges of utilizing the cloud for big data purposes.

Cloud Computing Overview: Cloud computing provides scalable infrastructure and tools that enable businesses to store, process, and analyze big data efficiently.

Why the Cloud for Big Data?

Scalability: The cloud offers virtually unlimited storage and computing power, which is ideal for big data's vast size and growth rate.

Cost Efficiency: Pay-as-you-go pricing models allow businesses to only pay for the resources they need at any given time.

Flexibility: Cloud services enable easy scaling up or down based on data processing needs and provide global access for remote teams.

The proliferation of big data has led to an insatiable demand for scalable, flexible, and cost-effective analytics solutions. Cloud-based big data analytics has emerged as a game-changer, enabling organizations to uncover hidden insights, improve decision-making, and drive business innovation. This chapter delves into the world of big data analytics in the cloud.

Cloud-based big data analytics has revolutionized the way organizations uncover insights and drive business value. By understanding the benefits, tools, techniques, and best practices, businesses can harness the power of big data analytics in the cloud.

Cloud computing has revolutionized the way big data is stored, processed, and analyzed. It offers the scalability, flexibility, and cost-efficiency that traditional on-premise solutions cannot match. By leveraging cloud-based big data platforms, organizations can gain valuable insights faster and more effectively, enabling better decision-making and innovation. As big data grows in volume and complexity, cloud-based solutions will continue to evolve, integrating advanced technologies like AI, machine learning, and edge computing to drive the future of data analytics.

CHAPTER 4 Cloud Networking: Connectivity and Security

G. Gayathri

Assistant Professor Department of Computer Science
Ponnaiyah Ramajayam Institute of Science
and Technology, Tamil Nadu, India

In this chapter, **Cloud Networking: Connectivity and Security**, we explore the critical aspects of networking in cloud computing environments. As organizations increasingly rely on cloud services, understanding how to establish secure and efficient connectivity is essential. This chapter covers the fundamental concepts of cloud networking, the various connectivity options, and the security measures necessary to protect data in transit.

Cloud networking enables secure, reliable, and scalable connectivity between cloud resources, users, and applications. This chapter explores cloud networking fundamentals, architectures, security measures, and best practices.

Cloud Networking Fundamentals

1. Cloud network architecture: hub-and-spoke, mesh, hybrid
2. Network protocols: TCP/IP, HTTP/S, FTP/S
3. Cloud network services: DNS, DHCP, load balancing
4. Network virtualization: VLANs, VPNs, SDN

Cloud Connectivity Options

Overview: The most common connectivity method, utilizing the public internet for accessing cloud resources.

Pros: Easy to set up, no additional costs.

Cons: Vulnerable to security threats, potential latency issues.

Overview: VPNs create a secure, encrypted connection over the public internet, allowing users to access cloud resources safely.

Cloud networking is essential for leveraging the full potential of cloud computing. Understanding the various connectivity options and implementing robust security measures are critical for protecting sensitive data and ensuring reliable performance. As technology continues to evolve, organizations must stay proactive in their approach to cloud networking and security, adopting best practices and preparing for future challenges.

Cloud networking enables secure, reliable, and scalable connectivity for cloud-based applications and services. Understanding cloud networking fundamentals, security measures, and best practices is crucial for designing and deploying secure cloud networks.

CHAPTER 5 MACHINE LEARNING AND AI IN THE CLOUD

S. Suganya

Assistant Professor Department of Computer Science
Ponnaiyah Ramajayam Institute of Science
and Technology, Tamil Nadu, India

This chapter, **Machine Learning and AI in the Cloud**, examines how cloud computing has revolutionized the fields of machine learning (ML) and artificial intelligence (AI). The cloud offers scalable resources, powerful computing capabilities, and access to vast amounts of data, enabling organizations to develop and deploy sophisticated ML and AI models efficiently. This chapter covers key concepts, tools, applications, and challenges related to ML and AI in the cloud.

Cloud-based machine learning (ML) and artificial intelligence (AI) have revolutionized data-driven decision-making, predictive analytics, and automation. This chapter explores cloud-based ML/AI concepts, services, applications, and best practices.

Benefits of Cloud-Based ML/AI

1. Scalability and flexibility
2. Reduced infrastructure costs
3. Faster model training and deployment
4. Enhanced collaboration and sharing
5. Access to pre-trained models and APIs

Machine Learning (ML): A subset of AI that enables systems to learn from data, improve their performance over time, and make predictions without being explicitly programmed.

Artificial Intelligence (AI): The broader concept encompassing any technique that enables machines to mimic human intelligence, including reasoning, learning, and problem-solving.

Importance of Cloud Computing for ML and AI:

Cloud platforms provide the computational power and storage required for processing large datasets, making them ideal for training complex ML models.

The cloud provides an essential infrastructure for organizations looking to harness the power of machine learning and artificial intelligence. With scalable resources, advanced tools, and pre-trained models, businesses can develop and deploy sophisticated AI solutions that drive innovation and efficiency. As technology continues to evolve, staying informed about emerging trends and best practices will be crucial for leveraging ML and AI effectively in the cloud.

Cloud-based machine learning and AI have transformed data-driven decision-making and automation. Understanding cloud-based ML/AI concepts, services, applications, and best practices enables organizations to harness the power of AI and drive business innovation.

CHAPTER 6 IDENTITY AND ACCESS MANAGEMENT IN THE CLOUD

R. Rajayogeswari

Assistant Professor Department of Computer Science
Ponnaiyah Ramajayam Institute of Science
and Technology, Tamil Nadu, India

This chapter, **Identity and Access Management in the Cloud**, delves into the critical aspects of managing user identities and controlling access to resources in cloud environments. As organizations increasingly move to the cloud, effective identity and access management (IAM) becomes essential to ensuring data security, compliance, and operational efficiency. This chapter covers the key concepts, components, and best practices associated with IAM in the cloud.

Identity and Access Management (IAM) is crucial for securing cloud resources, ensuring compliance, and enabling scalable, secure access. This chapter explores cloud IAM concepts, architectures, best practices, and solutions.

Overview: Digital identities represent users, devices, or applications within an organization and are used to authenticate and authorize access to resources.

Identity Attributes: Include usernames, passwords, roles, and permissions that define a user's access rights.

Authentication: The process of verifying the identity of a user or system (e.g., using passwords, biometrics, or multi-factor authentication).

Authorization: The process of granting or denying access to resources based on the authenticated user's permissions and roles.

Effective identity and access management is essential for securing cloud environments and protecting sensitive data. By implementing robust IAM practices and leveraging cloud-based solutions, organizations can ensure that only authorized users have access to critical resources, thereby reducing the risk of data breaches and enhancing overall security. As cloud technology continues to evolve, staying informed about IAM best practices and emerging trends will be crucial for organizations seeking to navigate the complexities of cloud security.

Cloud IAM is critical for securing cloud resources, ensuring compliance, and enabling scalable, secure access. Understanding cloud IAM concepts, architectures, best practices, and solutions enables organizations to protect their cloud infrastructure and data.

CHAPTER 7 CLOUD-BASED BLOCK CHAIN APPLICATIONS

S. Satya priya

Assistant Professor Department of Computer Science
Ponnaiyah Ramajayam Institute of Science
and Technology, Tamil Nadu, India

This chapter, **Cloud-Based Block Chain Applications**, explores the integration of block chain technology with cloud computing to deliver secure, scalable, and efficient solutions across various industries. By leveraging the strengths of both technologies, organizations can enhance transparency, trust, and efficiency in their operations. This chapter covers the fundamental concepts of block chain, its applications in the cloud, and the benefits and challenges associated with cloud-based block chain solutions.

Block chain technology has revolutionized secure, decentralized, and transparent data management. Cloud-based block chain applications have enabled scalable, secure, and cost-effective deployment. This chapter explores cloud-based block chain concepts, architectures, applications, and case studies.

Benefits of Cloud-Based Block chain

1. Scalability and flexibility
2. Reduced infrastructure costs
3. Enhanced security and compliance
4. Faster deployment and integration
5. Improved collaboration and interoperability

Future of Cloud-Based Block chain

1. Quantum computing and block chain security
2. Artificial intelligence (AI) and block chain integration
3. Internet of Things (IoT) and block chain connectivity
4. 5G networks and block chain scalability
5. Decentralized finance (DeFi) and block chain applications

Cloud-based block chain applications offer significant advantages in terms of scalability, cost efficiency, and security, making them ideal for a wide range of industries. By integrating the transparency and trust of block chain technology with the flexibility of cloud computing, organizations can drive innovation, enhance operational efficiency, and create new value propositions. As the technology continues to evolve, staying informed about trends and best practices will be crucial for organizations looking to leverage cloud-based block chain solutions effectively.



ACTIVE SERVER PROGRAMMING

**EDITED BY:
G.BRIYADHARSHINI**



978-93-6255-866-4

Active Server Programming
Copyright © 2023 by G. BRIYADHARSHINI

All rights reserved. No part of this book may be reproduced or transmitted in any form or by any means without written permission from the author.

ISBN: 978-93-6255-866-4

Publisher: PonnaIyah Ramajayam Institute of Science and Technology
(PRIST)

TABLE OF CONTENTS

| | |
|---|---|
| CHAPTER 1: ASP Architecture and Components.....1 K. Priyadahrshini | 1 |
| CHAPTER 2: ASP Core Concepts:2 P. Sakila | 2 |
| CHAPTER 3: SQL and Querying Data.....3 D.S. Chozhabharathi | 3 |
| CHAPTER 4 Session and Application State Management.....4 G. Gayathri | 4 |
| CHAPTER 5: Web Services and SOAP.....5 K. Priyadahrshini | 5 |
| CHAPTER 6: Integrating with Third-Party APIs.....6 R. Rajayogeswari | 6 |
| CHAPTER 7: Database Schema and SQL Reference.....7 S. Satya priya | 7 |

CHAPTER 1 ASP ARCHITECTURE AND COMPONENTS

K. Priyadahrshini

Assistant Professor Department of Computer Science
Ponnaiyah Ramajayam Institute of Science
and Technology, Tamil Nadu, India

This chapter, **ASP Architecture and Components**, provides an in-depth exploration of Active Server Pages (ASP), a server-side scripting technology used for creating dynamic web applications. We will cover the architecture of ASP, its core components, and how they interact to deliver responsive web experiences.

Active Server Pages (ASP) is a server-side scripting technology that enables developers to create dynamic web applications. Understanding the ASP architecture and components is crucial for building efficient, scalable, and secure web applications.

ASP Components

1. **ASP Engine:** The ASP engine is the core component responsible for parsing and executing ASP scripts.
2. **ASP Parser:** The ASP parser interprets ASP code and converts it into executable machine code.
3. **ASP Runtime:** The ASP runtime provides a set of built-in objects and functions for interacting with the web server, database, and file system.

ASP Objects:

- **Request:** represents the client's HTTP request
- **Response:** represents the server's HTTP response
- **Server:** provides access to server-side resources
- **Session:** manages user session state
- **Application:** manages application-wide settings

Understanding the architecture and components of ASP is crucial for developers working with this technology. While it may not be the latest web development framework, its foundational concepts and structure provide valuable insights into server-side programming and the evolution of web technologies. As the web continues to evolve, knowledge of ASP can aid in grasping more advanced frameworks like ASP.NET.

Understanding the ASP architecture and components is essential for building robust, efficient, and secure web applications. By leveraging the strengths of ASP and following best practices, developers can create scalable and maintainable web solutions.

CHAPTER 2 ASP CORE CONCEPTS

P. Sakila

Assistant Professor Department of Computer Science
Ponnaiyah Ramajayam Institute of Science
and Technology, Tamil Nadu, India

This chapter, **ASP Core Concepts**, provides an in-depth understanding of the fundamental principles and features of Active Server Pages (ASP) that enable the creation of dynamic web applications. By exploring these core concepts, developers can effectively utilize ASP to build responsive and interactive websites.

Active Server Pages (ASP) is a server-side scripting technology that enables developers to create dynamic web applications. This chapter covers the core concepts of ASP, including variables, data types, operators, control structures, functions, and object-oriented programming.

1. Functions: reusable blocks of code that return values.
2. Subroutines: reusable blocks of code that perform actions.
3. Function Arguments: passing parameters to function

ASP Built-in Functions

1. String Functions: Len, UCase, LCase, etc.
2. Date/Time Functions: Now, Date, Time, etc.
3. Math Functions: Abs, Int, Round, etc.
4. Array Functions: Array, UBound, LBound, etc.

Best Practices and Considerations

1. Code Organization: keep code organized and readable.
2. Variable Naming: use meaningful variable names.
3. Error Handling: anticipate and handle errors.
4. Security: validate user input and ensure data integrity.

Mastering ASP core concepts is essential for building robust, efficient, and scalable web applications. By understanding variables, data types, operators, control structures, functions, and object-oriented programming, developers can create dynamic and interactive web solutions.

Understanding the core concepts of ASP is essential for developers looking to create dynamic web applications. By mastering scripting languages, built-in objects, data access methods, and security practices, developers can leverage ASP's capabilities to build interactive and responsive websites. As technology evolves, knowledge of ASP forms a foundational understanding that can aid in transitioning to more advanced frameworks like ASP.NET.

CHAPTER 3 SQL AND QUERYING DATA

D.S. Chozhabharathi

Assistant Professor Department of Computer Science
Ponnaiyah Ramajayam Institute of Science
and Technology, Tamil Nadu, India

This chapter, **ASP Core Concepts**, delves into the fundamental principles and features of Active Server Pages (ASP), a server-side scripting environment that enables developers to create dynamic web applications. Understanding these core concepts is essential for effectively using ASP to build responsive and interactive websites.

ASP provides several built-in objects that facilitate common tasks:

Request Object: Captures data sent by the client (e.g., form inputs).

Response Object: Sends data back to the client, generating HTML content.

Session Object: Maintains user session data across requests.

Application Object: Stores application-wide data accessible to all users.

Structured Query Language (SQL) is a fundamental language for managing and querying relational databases. This chapter covers the basics of SQL, data modeling, and querying techniques.

SQL Fundamentals

1. SQL History and Evolution
2. Basic SQL Syntax
3. Data Types (Int, Varchar, Date, etc.)
4. SQL Commands (SELECT, INSERT, UPDATE, DELETE)

SQL is a powerful language for managing and querying relational databases. Mastering SQL fundamentals, data modeling, and querying techniques enables developers to efficiently store, retrieve, and analyze data

Understanding the core concepts of ASP is crucial for developing dynamic web applications. Mastery of scripting languages, built-in objects, data access methods, and security practices empowers developers to leverage ASP effectively, creating interactive and responsive websites. As technology progresses, foundational knowledge of ASP can facilitate a smoother transition to more advanced frameworks like ASP.NET.

CHAPTER 4 SESSION AND APPLICATION STATE MANAGEMENT

G. Gayathri

Assistant Professor Department of Computer Science

Ponnaiyah Ramajayam Institute of Science

and Technology, Tamil Nadu, India

This chapter, **Session and Application State Management**, explores the mechanisms available in ASP (and ASP.NET) for managing state in web applications. Given the stateless nature of HTTP, effective state management is crucial for maintaining user information and application data across multiple requests.

State management refers to the techniques used to preserve the state of an application or user across requests. In web applications, this is essential since HTTP is stateless, meaning each request is independent.

Session state allows developers to store user-specific data across multiple requests during a user's session. It is ideal for maintaining user information, such as login status or user preferences.

When a user accesses an ASP application, a new session is created on the server. A unique session identifier (Session ID) is generated and sent to the client, usually via a cookie. As the user makes requests, the server associates the Session ID with the stored session data.

Application state allows developers to store data that is shared across all users and sessions of the application. It is useful for storing global data, such as configuration settings or shared resources.

Managing state is crucial in web applications, enabling developers to store and retrieve user data, track user interactions, and maintain application consistency. This chapter explores session and application state management in ASP.

State Management Techniques

1. Cookies: using cookies to store user data.
2. Query Strings: passing data through query strings.
3. Hidden Fields: using hidden fields to store data.
4. View State: managing View State in ASP web forms.

Since application state is shared among all users, it's essential to manage access carefully to avoid conflicts or data corruption. Use locking mechanisms if necessary.

Application state persists for the duration of the application's lifecycle, until the application is restarted or stopped.

Effective session and application state management is vital for building robust, scalable, and secure web applications. Understanding ASP session and application state management enables developers to create efficient and user-friendly web experiences.

CHAPTER 5 Web Services and SOAP

K. Priyadahrshini

Assistant Professor Department of Computer Science
Ponnaiyah Ramajayam Institute of Science
and Technology, Tamil Nadu, India

This chapter, **Web Services and SOAP**, provides an overview of web services as a means of enabling communication between different software applications over the internet. It focuses on the Simple Object Access Protocol (SOAP), a protocol for exchanging structured information in web services.

Web services are software applications that communicate over the web using standardized protocols. They allow different applications from various sources to exchange data and interact with one another.

Web services enable interoperable communication between systems, allowing businesses to integrate and exchange data seamlessly. This chapter explores web services, SOAP (Simple Object Access Protocol), and their role in ASP development.

Components:

- A SOAP message is composed of the following elements:
- **Envelope:** Defines the start and end of the message.
- **Header:** Contains optional attributes for the message, such as authentication.
- **Body:** Contains the actual message or payload.
- **Fault:** Provides error and status information if something goes wrong.

SOAP Fundamentals

1. SOAP history and evolution
2. SOAP architecture (Envelope, Header, Body)
3. SOAP message structure (Request/Response)
4. SOAP data types (XML, XSD)

Web services and SOAP play a critical role in enabling communication between disparate systems. By understanding the structure of SOAP messages, how they work, and the advantages and disadvantages of using SOAP, developers can make informed decisions about when to use web services in their applications. The formal contracts defined by WSDL and the interoperability provided by SOAP make it a powerful choice for enterprise-level solutions.

Web services and SOAP enable seamless communication between systems, facilitating business integration and data exchange. Mastering SOAP and web services development in ASP enables developers to create robust, scalable, and secure web applications.

CHAPTER 6 INTEGRATING WITH THIRD-PARTY APIS

R. Rajayogeswari

Assistant Professor Department of Computer Science
Ponnaiyah Ramajayam Institute of Science
and Technology, Tamil Nadu, India

This chapter, **integrating with Third-Party APIs**, explores how to connect and interact with external services through their Application Programming Interfaces (APIs). Understanding this integration is crucial for enhancing the functionality of applications and leveraging external resources.

An Application Programming Interface (API) is a set of rules and protocols that allows different software applications to communicate with each other. APIs enable developers to access features or data from external services without having to understand their underlying code.

Based on REST (Representational State Transfer) architecture, typically using JSON for data exchange and HTTP methods (GET, POST, PUT, DELETE) for operations.

Integrating third-party APIs can add new features to applications without developing them from scratch (e.g., payment processing, mapping, social media sharing).

Integrating third-party APIs enables developers to leverage existing services, enhance functionality, and create innovative applications. This chapter explores API integration fundamentals, strategies, and best practices.

API Integration Strategies

1. API composition (mashing up multiple APIs)
2. API orchestration (sequencing API calls)
3. API caching and optimization
4. API error handling and debugging

Integrating third-party APIs enables developers to create robust, scalable, and innovative applications. Understanding API fundamentals, strategies, and best practices enables developers to successfully integrate APIs and enhance their applications.

CHAPTER 7 DATABASE SCHEMA AND SQL REFERENCE

S. Satya priya

Assistant Professor Department of Computer Science
Ponnaiyah Ramajayam Institute of Science
and Technology, Tamil Nadu, India

This chapter, **Database Schema and SQL Reference**, provides an overview of database schemas and the Structured Query Language (SQL), which is essential for managing and manipulating relational databases. Understanding these concepts is crucial for designing efficient databases and performing data operations

A database schema is a blueprint that defines the structure of a database. It includes the organization of data, the relationships between tables, and constraints on the data.

Structured Query Language (SQL) is a standardized language used to communicate with relational databases. SQL enables users to create, read, update, and delete data

A well-designed database schema and proficient SQL skills are crucial for efficient data storage, retrieval, and manipulation. This chapter provides a comprehensive reference for database schema design and SQL syntax

Database Schema Fundamentals

1. Entity-Relationship Modeling (ERM)
2. Database Design Principles (Normalization, DE normalization)
3. Table Relationships (One-to-One, One-to-Many, Many-to-Many)
4. Data Types (Int, Varchar, Date, etc.)

SQL Best Practices

1. Query Optimization
2. Indexing Strategies
3. Data Normalization
4. Error Handling and Debugging

A well-designed database schema and proficient SQL skills are essential for efficient data management. This chapter provides a comprehensive reference for database schema design and SQL syntax, enabling developers to create robust and scalable database applications.



OBJECT ORIENTED PROGRAMMING

EDITED BY
K.PRIYADHARSHINI



978-93-6255-012-5

Object Oriented Programming

Copyright © 2023 by K.Priyadharshini

All rights reserved. No part of this book may be reproduced or transmitted in any form or by any means without written permission from the author.

ISBN: 978-93-6255-012-5

Publisher: Ponnaiyah Ramajayam Institute of Science and Technology (PRIST)

TABLE OF CONTENT

| | |
|---|--------|
| CHAPTER 1 : Foundations of Object-Oriented Development: Concepts |1 |
| M. Aarathi | |
| CHAPTER 2: Foundations of Object-Oriented Development: Modeling, and Relationships |3 |
| R. Kalaiselvi | |
| CHAPTER 3 : Advanced Object Modeling, Dynamic Modeling |4 |
| P.Karthik | |
| CHAPTER 4 : Function Modeling in Object-Oriented Development |5 |
| K.Vijayabaskar | |
| CHAPTER 5: Object-Oriented Methodology in Software Engineering: Overview, Analysis, and Case Study |6 |
| R. Rajayogeswari | |
| CHAPTER 6: System Design: Strategies and Techniques for Effective Software Design and Implementation |7 |
| D.S.Chozhabharathi | |
| CHAPTER 7: Object oriented Programming Essentials and Unix and shell Programming |8 |
| H. Parveenbegum | |

CHAPTER 1

FOUNDATIONS OF OBJECT-ORIENTED DEVELOPMENT: CONCEPTS

M.AARTHI

Assistant Professor, Department of Computer Science, Ponnaiyah Ramajayam Institute of Science and Technology, Tamil Nadu, India.

Object-Oriented Programming or OOPs refers to languages that use objects in programming. Object-oriented programming aims to implement real-world entities like inheritance, hiding, polymorphism, etc in programming. The main aim of OOP is to bind together the data and the functions that operate on them so that no other part of the code can access this data except that function.

OOPs Concepts:

- ❖ Class
- ❖ Objects
- ❖ Data Abstraction
- ❖ Encapsulation
- ❖ Inheritance
- ❖ Polymorphism
- ❖ Dynamic Binding
- ❖ Message Passing

1. Class:

A class is a user-defined data type. It consists of data members and member functions, which can be accessed and used by creating an instance of that class. It represents the set of properties or methods that are common to all objects of one type. A class is like a blueprint for an object.

2. Object:

It is a basic unit of Object-Oriented Programming and represents the real-life entities. An Object is an instance of a Class. When a class is defined, no memory is allocated but when it is instantiated (i.e. an object is created) memory is allocated. An object has an identity, state, and behavior. Each object contains data and code to manipulate the data. Objects can interact without having to know details of each other's data or code, it is sufficient to know the type of message accepted and type of response returned by the objects.

3. Data Abstraction:

Data abstraction is one of the most essential and important features of object-oriented programming. Data abstraction refers to providing only essential information about the data to the outside world, hiding the background details or implementation. Consider a real-life example of a man driving a car. The man only knows that pressing the accelerators will increase the speed of the car or applying brakes will stop the car, but he does not know about how on pressing the accelerator the speed is increasing, he does not know about the inner mechanism of the car or the implementation of the accelerator, brakes, etc in the car.

CHAPTER 2

FOUNDATIONS OF OBJECT-ORIENTED DEVELOPMENT: MODELING, AND RELATIONSHIPS

R. KALAISELVI

Assistant Professor, Department of Computer Science, Ponnaiyah Ramajayam Institute of Science and Technology, Tamil Nadu, India.

Intention of object oriented modeling and design is to learn how to apply object -oriented concepts to all the stages of the software development life cycle. Object-oriented modeling and design is a way of thinking about problems using models organized around real world concepts. The fundamental construct is the object, which combines both data structure and behavior.

Purpose of Models:

1. Testing a physical entity before building it
2. Communication with customers
3. Visualization
4. Reduction of complexity

Types of Models:

There are 3 types of models in the object oriented modeling and design are: Class Model, State Model, and Interaction Model. These are explained as following below.

1. Class Model:

The class model shows all the classes present in the system. The class model shows the attributes and the behavior associated with the objects.

The class diagram is used to show the class model. The class diagram shows the class name followed by the attributes followed by the functions or the methods that are associated with the object of the class. Goal in constructing class model is to capture those concepts from the real world that are important to an application.

2. State Model:

State model describes those aspects of objects concerned with time and the sequencing of operations – events that mark changes, states that define the context for events, and the organization of events and states. Actions and events in a state diagram become operations on objects in the class model. State diagram describes the state model.

3. Interaction Model:

Interaction model is used to show the various interactions between objects, how the objects collaborate to achieve the behavior of the system as a whole.

The following diagrams are used to show the interaction model:

- Use Case Diagram, Sequence Diagram, Activity Diagram

CHAPTER 3
ADVANCED OBJECT MODELING, DYNAMIC MODELING
P.KARTHIK

Assistant Professor, Department of Computer Science, Ponnaiyah Ramajayam Institute of Science and Technology, Tamil Nadu, India.

Dynamic Modelling describes those aspect of the system that are concerned with time and sequencing of the operations. It is used to specify and implement the control aspect of the system. Dynamic model is represented graphically with the help of state diagrams. It is also known as state modelling. State model consist of multiple state diagrams, one for each class with temporal behavior that is important to an application. State diagram relates with events and states. Events represents external functional activity and states represents values objects.

Events:

An event is something that happen at a particular point in particular time such as a person press button or train 15930 departs from Amritsar. Event conveys information from one object to another.

The events are of three types: Signal event, Change event, and Time event.

These are explained as following below.

1. Signal event :

A signal event is an particular occurrence in time. A signal is a explicit one-way transmission of information from one object to another. A signal event is the event of sending or receiving signal. When an object send signal to another object it await for acknowledgement but acknowledgement signal is the separate signal under the control of second object, which may or may not choose to send it.

2. Change event :

It is caused by the satisfaction of a boolean expression. The intent of the change event is that the expression is tested continually whenever the expression changes from false to true. The UML notation for a change event is the keyword when followed by a parenthesized boolean expression.

3. Time event :

It is caused by occurrence of an absolute or the elapse of time interval. The UML notation for absolute time is the keyword when followed by a parenthesized expression involving time and for the time interval is keyword after followed by a parenthesized expression that evaluates time duration.

CHAPTER 4

FUNCTION MODELING IN OBJECT-ORIENTED DEVELOPMENT

K.VIJAYABASKAR

Assistant Professor, Department of Computer Science, Ponnaiyah Ramajayam Institute of Science and Technology, Tamil Nadu, India.

Functional Modelling:

- A functional model of a system specifies how the output values are computed in the system from the input values, without considering the control aspects of the computation.
- This represents the functional view of the system – the mapping from inputs to outputs and the various steps involved in the mapping.
- The functional model of a system can be represented by a data flow diagram(DFD).
- As processes represent operations and in an object – oriented system, most of the processing is done by operations on classes, all processes should show up as operations on classes.

provides the outline that what the system is supposed to do. It does not describe what is the need of evaluation of data, when they are evaluated and how they are evaluated apart from all it only represents origin of data values. It describes the function of internal processes with the help of DFD.

DFD (Data Flow Diagram)

Data Flow Diagrams: Function modelling is represented with the help of DFDs. DFD is the graphically representation of data. It shows the input, output and processing of the system. When we are trying to create our own business, website, system, project then there is need to find out how information passes from one process to another so all are done by DFD. There are number of levels in DFD but upto third level DFD is sufficient for understanding of any system.

The basic components of the DFD are:

External Entity: External entity is the entity that takes information and gives information to the system. It is represented with rectangle.

Data Flow: The data passes from one place to another is shown by data flow. Data flow is represented with arrow and some information written over it.

Process: It is also called function symbol. It is used to process all the information .If there are calculations so all are done in the process part .It is represented with circle and name of the process and level of DFD written inside it.

Data Store: It is used to store the information and retrieve the stored information. It is represented with double parallel lines.

CHAPTER 5

OBJECT-ORIENTED METHODOLOGY IN SOFTWARE ENGINEERING: OVERVIEW, ANALYSIS, AND CASE STUDY

R. RAJAYOGESWARI

Assistant Professor, Department of Computer Science, Ponnaiyah Ramajayam Institute of Science and Technology, Tamil Nadu, India.

Object-Oriented Analysis and Design (OOAD) is a software engineering methodology that employs object-oriented principles to model and design complex systems. It involves analyzing the problem domain, representing it using objects and their interactions, and then designing a modular and scalable solution. It helps create systems that are easier to understand, maintain, and extend by organizing functionality into reusable and interconnected components.

Important Aspects of OOAD

Here are some important aspects of OOAD:

- ✓ **Object-Oriented Programming:** Object-oriented programming involves modeling real-world objects as software objects, with properties and methods that represent the behavior of those objects. OOAD uses this approach to design and implement software systems.
- ✓ **Design Patterns:** Design patterns are reusable solutions to common problems in software design. OOAD uses design patterns to help developers create more maintainable and efficient software systems.
- ✓ **UML Diagrams:** Unified Modeling Language (UML) is a standardized notation for creating diagrams that represent different aspects of a software system. OOAD uses UML diagrams to represent the different components and interactions of a software system.
- ✓ **Use Cases:** Use cases are a way of describing the different ways in which users interact with a software system. OOAD uses use cases to help developers understand the requirements of a system and to design software systems that meet those requirements.

Object-Oriented Analysis

Object-Oriented Analysis (OOA) is the first technical activity performed as part of object-oriented software engineering. OOA introduces new concepts to investigate a problem. It is based on a set of basic principles, which are as follows:

- ✓ **The information domain is modeled:**

Lets say you're building a game. OOA helps you figure out all the things you need to know about the game world – the characters, their features, and how they interact. It's like making a map of everything important.

CHAPTER 6

SYSTEM DESIGN: STRATEGIES AND TECHNIQUES FOR EFFECTIVE SOFTWARE DESIGN AND IMPLEMENTATION

D.S.CHOZHABHARATHI

Assistant Professor, Department of Computer Science, Ponnaiyah Ramajayam Institute of Science and Technology, Tamil Nadu, India.

A good system design is to organize the program modules in such a way that are easy to develop and change. Structured design techniques help developers to deal with the size and complexity of programs. Analysts create instructions for the developers about how code should be written and how pieces of code should fit together to form a program.

Software Engineering is the process of designing, building, testing, and maintaining software. The goal of software engineering is to create software that is reliable, efficient, and easy to maintain. System design is a critical component of software engineering and involves making decisions about the architecture, components, modules, interfaces, and data for a software system.

System Design Strategy refers to the approach that is taken to design a software system. There are several strategies that can be used to design software systems, including the following:

- ✓ **Top-Down Design:** This strategy starts with a high-level view of the system and gradually breaks it down into smaller, more manageable components.
- ✓ **Bottom-Up Design:** This strategy starts with individual components and builds the system up, piece by piece.
- ✓ **Iterative Design:** This strategy involves designing and implementing the system in stages, with each stage building on the results of the previous stage.
- ✓ **Incremental Design:** This strategy involves designing and implementing a small part of the system at a time, adding more functionality with each iteration.

Agile Design: This strategy involves a flexible, iterative approach to design, where requirements and design evolve through collaboration between self-organizing and cross-functional teams.

Importance of System Design Strategy:

1. If any pre-existing code needs to be understood, organized, and pieced together.
2. It is common for the project team to have to write some code and produce original programs that support the application logic of the system.

There are many strategies or techniques for performing system design. They are:

- ✚ **Bottom-up approach**
- ✚ **Top-down approach**

CHAPTER 7

OBJECT ORIENTED PROGRAMMING ESSENTIALS AND UNIX AND SHELL PROGRAMMING

H. PARVEENBEGUM

Assistant Professor, Department of Computer Science, Ponnaiyah Ramajayam Institute of Science and Technology, Tamil Nadu, India.

We are indirectly interacting with the shell. While running Ubuntu, Linux Mint, or any other Linux distribution, we are interacting with the shell by using the terminal. In this article we will discuss Linux shells and shell scripting so before understanding shell scripting we have to get familiar with the following terminologies:

- ❖ Kernel
- ❖ Shell
- ❖ Terminal

Kernel

The kernel is a computer program that is the core of a computer's operating system, with complete control over everything in the system. It manages the following resources of the Linux system –

- ❖ File management
- ❖ Process management
- ❖ I/O management
- ❖ Memory management
- ❖ Device management etc.

It is often mistaken that Linus Torvalds has developed Linux OS, but actually, he is only responsible for the development of the Linux kernel.

Complete Linux system = Kernel + GNU system utilities and libraries + other management scripts + installation scripts.

Shell

A shell is a special user program that provides an interface for the user to use operating system services. Shell accepts human-readable commands from users and converts them into something which the kernel can understand. It is a command language interpreter that executes commands read from input devices such as keyboards or from files. The shell gets started when the user logs in or starts the terminal.

Shell is broadly classified into two categories –

- ❖ Command Line Shell
- ❖ Graphical shell



DATABASE SYSTEM

Edited by

DR.K.T.SENTHILKUMAR



978-93-6255-569-4

Database System

Copyright © 2023 by K.T.SenthilKumar

All rights reserved. No part of this book may be reproduced or transmitted in any form or by any means without written permission from the author.

ISBN: 978-93-6255-569-4

Publisher: Ponnaiyah Ramajayam Institute of Science and Technology (PRIST)

TABLE OF CONTENTS

| | |
|--|----|
| CHAPTER 1: Understanding Data, Models, and Evolution | 1 |
| M. Aarthi | |
| CHAPTER 2: Exploring Relational Database Fundamentals | 3 |
| P.Karthik | |
| CHAPTER3: Database Fundamentals: From Keys to ER Diagrams..... | 5 |
| R. Rajayogeswari | |
| CHAPTER 4: Mastering Database Design..... | 7 |
| R. Kalaiselvi | |
| CHAPTER 5: Database Design: From Normalization to SQL Basics..... | 8 |
| Dr.K.T.SenthilKumar | |
| CHAPTER 6: Advanced SQL Techniques..... | 9 |
| Dr.G PREETHI | |
| CHAPTER 7: Relational Set Operations, Joins, Sub queries, and Functions..... | 10 |
| R. Banumathi | |
| CHAPTER 8: Mastering PL/SQL..... | 12 |
| R.Suganya | |
| CHAPTER 9: Fundamentals to Cursors and Exceptions Handling Using SQL.... | 13 |
| P.Sakila | |

CHAPTER 1

UNDERSTANDING DATA, MODELS, AND EVOLUTION

M. AARTHI

Assistant Professor, Department of Computer Science, Ponnaiyah Ramajayam Institute of Science and Technology, Tamil Nadu, India.

Understanding data, models, and evolution involves exploring how data is structured, how models are created to represent data, and how these models can evolve over time. Here's a brief overview:

UNDERSTANDING DATA

1. Definition: Data consists of raw facts and figures that can be analyzed to gain insights or inform decisions. It serves as the foundational element in research, analysis, and decision-making processes.

2. Types of Data:

- **Quantitative Data:** Numerical data that can be measured and analyzed statistically (e.g., sales figures, temperature readings).
 - *Subtypes:*
 - **Discrete Data:** Countable data (e.g., number of students).
 - **Continuous Data:** Measurable data that can take on any value within a range (e.g., height, weight).
- **Qualitative Data:** Descriptive data that can be categorized based on traits and characteristics (e.g., colors, opinions).
 - *Subtypes:*
 - **Nominal Data:** Categories without a specific order (e.g., types of fruit).
 - **Ordinal Data:** Categories with a defined order (e.g., customer satisfaction ratings).

3. Data Collection Methods:

- **Surveys:** Gathering responses from a sample population.
- **Experiments:** Conducting controlled studies to gather data.
- **Observational Studies:** Collecting data by observing subjects in their natural environment.
- **Administrative Data:** Using existing records from organizations (e.g., health records, financial data).

CHAPTER 2

EXPLORING RELATIONAL DATABASE FUNDAMENTALS

P.KARTHIK

Assistant Professor, Department of Computer Science, Ponnaiyah Ramajayam Institute of Science and Technology, Tamil Nadu, India.

Relational Database Management System

The Structured Query Language (SQL) is a relational database's standard user and application software interface. Most of today's IT systems and applications are built on relational databases.

Because the table is kept in a relation model, relational databases are widely used because they can easily handle large volumes of data and complex queries. The tables in the relational database can be linked in a variety of ways, much as the links between the data in an entity's relationship diagram:

- A record in one table's characteristics may be connected to a record in another table.
- A record in one table may be connected to numerous records in another.
- Many records in one table might be connected to many records in another table.

Therefore, with the help of this relationship model, developers and analysts can more quickly understand how the various pieces of data relate to one another and process queries.

Key Factors to Consider When Selecting a Relational Database

Here are some important factors to take into account when choosing a relational database before we move on to the sections on the common types of Relational Database Management System:

Initial Setup

When setting up a database system, ensure that it supports synchronisation with other platforms and integration into the existing data architecture. These elements are required for the DBMS to be optimised for operations and continuous workflow.

Data Security

Every DBMS typically offers a variety of security measures. To protect your data, you must consider whether the database system you choose has features like encryption, programmable procedures, and access privileges. Make that the database system has authorisation and authentication for access restrictions, which enable developers to specify access permissions.

CHAPTER 3

DATABASE FUNDAMENTALS: FROM KEYS TO ER DIAGRAMS

R. RAJAYOGESWARI

Assistant Professor, Department of Computer Science, Ponnaiyah Ramajayam Institute of Science and Technology, Tamil Nadu, India.

1. Keys in Relational Databases

Primary Key:

- A unique identifier for each record in a table.
- Ensures that no two rows have the same value in this column(s).
- Example: A CustomerID in a customer table.

Foreign Key:

- A field (or group of fields) in one table that links to the primary key in another table.
- Establishes relationships between tables and enforces referential integrity.
- Example: CustomerID in an Orders table that links back to the Customers table.

Composite Key:

- A primary key that consists of two or more columns.
- Used when a single column is not sufficient to uniquely identify a record.
- Example: A combination of OrderID and ProductID in an order details table.

Candidate Key:

- A column or a set of columns that can uniquely identify a record in a table.
- One of the candidate keys is chosen as the primary key.

Surrogate Key:

- A unique identifier for a table, often an auto-incrementing number or UUID.
- Does not have a business meaning and is used solely for identifying records.

2. Relationships in Databases

One-to-One (1:1):

- Each record in Table A is linked to one record in Table B.
- Example: A person and their passport.

One-to-Many (1):

- A single record in Table A can be associated with multiple records in Table B.

CHAPTER 4

MASTERING DATABASE DESIGN

R. KALAISELVI

Assistant Professor, Department of Computer Science, Ponnaiyah Ramajayam Institute of Science and Technology, Tamil Nadu, India.

Database Design

Database design is the process of creating a detailed data model of a database. This involves defining the structure, storage, and retrieval mechanisms of the data to ensure it meets the needs of the users and applications that will interact with it. A well-designed database allows for efficient data management, retrieval, and storage, ensuring data integrity and security.

Importance of Database Design

Effective database design is essential for several reasons:

- **Efficiency:** Properly designed databases ensure that data is stored efficiently and can be retrieved quickly, enhancing the overall performance of the system.
- **Scalability:** A good design makes it easier to scale the database as the amount of data grows or as the application requirements change.
- **Data Integrity:** Ensures that the data remains accurate and consistent throughout its lifecycle.
- **Maintenance:** Simplifies maintenance tasks, such as updates and backups, reducing the risk of errors and downtime.

Database Design Process

The database design process can be broken down into several stages:

- Requirements Analysis
- Conceptual Design
- Logical Design
- Physical Design
- Testing and Evaluation
- Deployment
- Maintenance and Monitoring

CHAPTER 5

DATABASE DESIGN: FROM NORMALIZATION TO SQL BASICS

DR.K.T.SENTHILKUMAR

Assistant Professor, Department of Computer Science, Ponnaiyah Ramajayam Institute of Science and Technology, Tamil Nadu, India.

“Database normalization is the process of restructuring a relational database in accordance with a series of so-called normal forms in order to reduce data redundancy and improve data integrity. It was first proposed by Edgar F. Codd as an integral part of his relational model.

Normalization entails organizing the columns (attributes) and tables (relations) of a database to ensure that their dependencies are properly enforced by database integrity constraints. It is accomplished by applying some formal rules either by a process of synthesis (creating a new database design) or decomposition (improving an existing database design).”

Database normalization

Database Normalization is a process and it should be carried out for every database you design. The process of taking a database design, and apply a set of formal criteria and rules, is called Normal Forms.

The database normalization process is further categorized into the following types:

1. First Normal Form (1 NF)
2. Second Normal Form (2 NF)
3. Third Normal Form (3 NF)
4. Boyce Codd Normal Form or Fourth Normal Form (BCNF or 4 NF)
5. Fifth Normal Form (5 NF)
6. Sixth Normal Form (6 NF)

One of the driving forces behind database normalization is to streamline data by reducing redundant data. Redundancy of data means there are multiple copies of the same information spread over multiple locations in the same database.

CHAPTER 6

ADVANCED SQL TECHNIQUES

Dr.G PREETHI

Assistant Professor, Department of Computer Science, Ponnaiyah Ramajayam Institute of Science and Technology, Tamil Nadu, India.

Advanced SQL techniques and strategies not only streamline the data analysis process but also help in generating valuable insights.

we will explore seven advanced SQL techniques that every data scientist should master.

1. Common Table Expression (CTE)

A Common Table Expression (CTE) is a temporary result set that you can reference within a SELECT, INSERT, UPDATE, or DELETE statement.

CTEs simplify complex queries, improve readability, and can be used for recursive queries.

It is especially helpful in a SQL interview to make your code easy to understand for the interviewer.

2. Window Functions

Window functions perform calculations across a set of rows related to the current row. They allow you to rank, aggregate, and compute running totals without the need for subqueries or self-joins.

3. UPSERT

UPSERT is a combination of UPDATE and INSERT. It allows you to insert a new row or update an existing one if there's a conflict with a unique constraint or primary key.

4. Recursive Queries

Recursive queries retrieve hierarchical or tree-structured data by repeatedly executing a subquery that refers to itself.

5. DynamicSQL

Dynamic SQL enables you to build and execute SQL statements dynamically at runtime. This is useful for creating flexible queries or procedures that can adapt to various conditions.

CHAPTER 7

RELATIONAL SET OPERATIONS, JOINS, SUB QUERIES, AND FUNCTIONS

R. BANUMATHI

Assistant Professor, Department of Computer Science, Ponnaiyah Ramajayam Institute of Science and Technology, Tamil Nadu, India.

SQL is an abbreviation for **Structured Query Language** which is a standardized data-based development language. SQL allows you to connect to and modify databases or large sets of information. SQL was adopted as an **American National Standards Institute (ANSI)** specification in 1986 along with an **International Organisation for Standardisation (ISO)** benchmark in 1987. SQL is a type of database communication language but it is easier than other competitive coding languages. It is an accepted standard for systems that manage relational databases, as defined by ANSI (American National Standards Institute).

Statements in SQL are utilized for performing operations such as updating or retrieving information from a database. SQL requires no technical knowledge, only the usage of simple terms such as “select,” “insert into,” and “update.” It employs standardized terminology. SQL’s standardized language makes it extremely approachable to all users. SQL is a very in-demand coding language in the current era as there is a rush to manage huge databases and understand the complex information stored in them. Over several years the trend to learn SQL is gathering pace and many students prefer to join the **best SQL training institutes** in their city. SevenMentor Institute is one of such similar **SQL training institutes** with the highest ratings across many cities in India. Please consider having a look at our **SQL Training curriculum** and also book a free demo session to make your assessment.

SQL Joins and Set Operators:

SQL has many diverse use cases and functions which enables it to be used in many scenarios and on every type of database. Two of these functions are the Joins function and the Set Operator function in SQL. These are less commonly known but have become an effective feature of SQL programming in recent times.

SQL Joins:

SQL joins are employed to integrate information or records from multiple tables that have at least one common field. SQL joins are classified primarily into **INNER JOIN, LEFT JOIN, RIGHT JOIN, and FULL JOIN.**

A **SQL JOIN** is a technique for retrieving data stored in more than one table within a database. This article provides a brief description of how data from a specific SQL join will appear. SQL joins are commonly depicted using Venn charts, therefore each example has a related Venn diagram, suitable SELECT command, and result database.

CHAPTER 8

MASTERING PL/SQL

R.SUGANYA

Assistant Professor, Department of Computer Science, Ponnaiyah Ramajayam Institute of Science and Technology, Tamil Nadu, India.

Conditional Compilation

This feature enables you to selectively include code depending on the values of the conditions evaluated during compilation. For example, conditional compilation enables you to determine which PL/SQL features in a PL/SQL application are used for specific database releases.

The latest PL/SQL features in an application can be run on a new database release while at the same time those features can be conditionalized so that the same application is compatible with a previous database release. Conditional compilation is also useful when you want to execute debugging procedures in a development environment, but want to turn off the debugging routines in a production environment.

Dynamic Wrap

DBMS_DDL wrap subprograms obfuscate (hide) dynamically generated PL/SQL code units in an Oracle database so that implementation details are hidden from users.

PLS_INTEGER Datatype Update

The range of the PLS_INTEGER datatype is -2147483648 to 2147483647, represented in 32 bits.

New Features in PL/SQL for Oracle Database 10g Release 1 (10.1)

Improved Performance

PL/SQL performance is improved across the board. Most improvements are automatic, with no action required from you. Global optimization of PL/SQL code is controlled by the PLSQL_OPTIMIZE_LEVEL initialization parameter. The default optimization level improves performance for a broad range of PL/SQL operations. Most users should never need to change the default optimization level.

Enhancements to PL/SQL Native Compilation

The configuration of initialization parameters and the command setup for native compilation has been simplified. The only required parameter is PLSQL_NATIVE_LIBRARY_DIR. The parameters related to the compiler, linker, and make utility have been obsoleted. Native compilation is turned on and off by a separate initialization parameter, PLSQL_CODE_TYPE, rather than being one of several options in the PLSQL_COMPILER_FLAGS parameter, which is now deprecated.

CHAPTER 9

FUNDAMENTALS TO CURSORS AND EXCEPTIONS HANDLING USING SQL

P.SAKILA

Assistant Professor, Department of Computer Science, Ponnaiyah Ramajayam Institute of Science and Technology, Tamil Nadu, India.

Cursor in SQL

Cursor is a Temporary Memory or Temporary Work Station. It is Allocated by Database Server at the Time of Performing DML(Data Manipulation Language) operations on the Table by the User. Cursors are used to store Database Tables.

There are 2 types of Cursors: Implicit Cursors, and Explicit Cursors. These are explained as following below.

1. **Implicit Cursors:** Implicit Cursors are also known as Default Cursors of SQL SERVER. These Cursors are allocated by SQL SERVER when the user performs DML operations.
2. **Explicit Cursors:** Explicit Cursors are Created by Users whenever the user requires them. Explicit Cursors are used for Fetching data from Table in Row-By-Row Manner.

Exception Handling in PL/SQL

An exception is an error which disrupts the normal flow of program instructions. PL/SQL provides us the exception block which raises the exception thus helping the programmer to find out the fault and resolve it.

There are two types of exceptions defined in PL/SQL

1. **User defined exception:** SQL Server allows users to define custom exceptions using RAISEERROR or by creating custom error messages with sp_addmessage. These user-defined exceptions can be raised and caught within stored procedures or T-SQL code.
2. **System defined exceptions:** SQL Server provides built-in system-defined exceptions that help handle various errors and exceptions that can occur during database operations. These exceptions are predefined and can be caught and handled using TRY... CATCH blocks.



DATA MINING

Edited by

K.PRIYADHARSHINI



978-93-6255-166-5

Data Mining

Copyright © 2023 by K.Priyadharshini

All rights reserved. No part of this book may be reproduced or transmitted in any form or by any means without written permission from the author.

ISBN: 978-93-6255-166-5

Publisher: Ponnaiyah Ramajayam Institute of Science and Technology (PRIST)

TABLE OF CONTENT

| | |
|---|--------|
| CHAPTER 1 An Introduction to Data Mining |1 |
| K.Vijayabaskar | |
| CHAPTER 2 Association Rules Mining: From Basics to Advanced Techniques |2 |
| P.Karthik | |
| CHAPTER 3 Mastering Classification: From Decision Trees to Naïve Bayes and Beyond |3 |
| M.Aarthi | |
| CHAPTER 4 Exploring Cluster Analysis: Techniques |4 |
| Dr.K.Raja | |
| CHAPTER 5 Exploring Cluster Analysis: Methods, and Applications |5 |
| R. Rajayogeswari | |
| CHAPTER 6 Web Data Mining: Techniques |6 |
| K.Priyadharshini | |
| CHAPTER 7 Web Data Mining: Tools for Extracting Insights from the Web |7 |
| G.Gayathri | |

CHAPTER 1

AN INTRODUCTION TO DATA MINING

K.VIJAYABASKAR

Assistant Professor, Department of Computer Science, Ponnaiyah Ramajayam Institute of Science and Technology, Tamil Nadu, India.

Data Mining

Data mining is the process of extracting useful information from large sets of data. It involves using various techniques from statistics, machine learning, and database systems to identify patterns, relationships, and trends in the data. This information can then be used to make data-driven decisions, solve business problems, and uncover hidden insights. Applications of data mining include customer profiling and segmentation, market basket analysis, anomaly detection, and predictive modeling. Data mining tools and technologies are widely used in various industries, including finance, healthcare, retail, and telecommunications.

In general terms, “Mining” is the process of extraction of some valuable material from the earth e.g. coal mining, diamond mining, etc. In the context of computer science, “Data Mining” can be referred to as knowledge mining from data, knowledge extraction, data/pattern analysis, data archaeology, and data dredging. It is basically the process carried out for the extraction of useful information from a bulk of data or data warehouses. One can see that the term itself is a little confusing.

In the case of coal or diamond mining, the result of the extraction process is coal or diamond. But in the case of Data Mining, the result of the extraction process is not data!! Instead, data mining results are the patterns and knowledge that we gain at the end of the extraction process. In that sense, we can think of Data Mining as a step in the process of Knowledge Discovery or Knowledge Extraction.

Technically, data mining is the computational process of analyzing data from different perspectives, dimensions, angles and categorizing/summarizing it into meaningful information.

Data Mining can be applied to any type of data e.g. **Data Warehouses, Transactional Databases, Relational Databases, Multimedia Databases, Spatial Databases, Time-series Databases, World Wide Web.**

Data Mining as a Whole Process

The whole process of Data Mining consists of three main phases:

- Data Pre-processing – Data cleaning, integration, selection, and transformation takes place
- Data Extraction – Occurrence of exact data mining
- Data Evaluation and Presentation – Analyzing and presenting results.

CHAPTER 2

ASSOCIATION RULES MINING: FROM BASICS TO ADVANCED TECHNIQUES

P.KARTHIK

Assistant Professor, Department of Computer Science, Ponnaiyah Ramajayam Institute of Science and Technology, Tamil Nadu, India.

Association rule learning is a machine learning technique used for discovering interesting relationships between variables in large databases. It is designed to detect strong rules in the database based on some interesting metrics. For any given multi-item transaction, association rules aim to obtain rules that determine how or why certain items are linked. Association rules are created for finding information about general if-then patterns using specific criteria with support and trust to define what the key relationships are. They help to show the frequency of an item in specific data since confidence is defined by the number of times an if-then statement is found to be true.

Types of Association Rules:

There are various types of association rules in data mining:-

- Multi-relational association rules
- Generalized association rules
- Quantitative association rules
- Interval information association rules

1. Multi-relational association rules: Multi-Relation Association Rules (MRAR) is a new class of association rules, different from original, simple, and even multi-relational association rules (usually extracted from multi-relational databases), each rule element consists of one entity but many a relationship. These relationships represent indirect relationships between entities.

2. Generalized association rules: Generalized association rule extraction is a powerful tool for getting a rough idea of interesting patterns hidden in data. However, since patterns are extracted at each level of abstraction, the mined rule sets may be too large to be used effectively for decision-making. Therefore, in order to discover valuable and interesting knowledge, post-processing steps are often required. Generalized association rules should have categorical (nominal or discrete) properties on both the left and right sides of the rule.

3. Quantitative association rules: Quantitative association rules is a special type of association rule. Unlike general association rules, where both left and right sides of the rule should be categorical (nominal or discrete) attributes, at least one attribute (left or right) of quantitative association rules must contain numeric attributes.

CHAPTER 3

MASTERING CLASSIFICATION: FROM DECISION TREES TO NAÏVE BAYES AND BEYOND

M.AARTHI

Assistant Professor, Department of Computer Science, Ponnaiyah Ramajayam Institute of Science and Technology, Tamil Nadu, India.

The use of technology is at its peak. Many companies try to reduce the work and get an efficient result in a specific amount of time. But a large amount of data is being processed each day that is being stored and turned into large datasets. To get useful information, the dataset needs to be analyzed so that one can extract knowledge by training the machine. Thus, it is important to analyze and extract knowledge from a large dataset.

We have used two popular classification techniques- Decision tree and Naive Bayes to compare the performance of the classification of our data set. We have taken student performance dataset that has 480 observations. We have classified these students into different groups and then calculated the accuracy of our classification by using the R language. Decision tree uses a divide and conquer method including some rules that makes it easy for humans to understand. The Naive Bayes theorem includes an assumption that the pair of features being classified are independent. It is based on the Bayes theorem.

Every industry is very concerned about data collection and requires accurate and appropriate information that will help it in decision making. This huge growth in data requires new techniques and automated tools that can be helpful in handling a vast amount of data by extracting useful information and knowledge from the transient data. Such a need for transformation leads us to a generation of a technique called data mining.

There are many algorithms that can be used to extract knowledge that can be useful in big data. But these algorithms differ in terms of how they “learn” about data for prediction at a high level. That is why the algorithms are classified into two categories: supervised learning and unsupervised learning. Supervised Learning is a learning method that is used to provide an algorithm with data which is already assigned with correct answer, that is some records will be tagged with the output variable of interest and then the machine will be provided with new dataset where the output variable will not be known and that the algorithm "learns" how to predict the output values for new records by analyzing the training data (portion of data used to fit a model) and using the labeled data. Supervised learning is classified into two algorithms: classification and regression. Both are related to prediction.

- **Classification algorithm:** A classification algorithm takes discrete values and is used to predict the target class to which data samples belong. For example, given a dataset of images. On the basis of the training data we need to predict whether the image is of cats or of dogs and accordingly classify into class labels as "cats" and "dogs". The labels basically come in a categorical form.

- **Regression Algorithm:** A regression algorithm takes continuous values and is used to predict the real or continuous valued output. For example, we are given the size of the house, we need to predict the price (real output variable) for the house.

CHAPTER 4

EXPLORING CLUSTER ANALYSIS: TECHNIQUES

DR.K.RAJA

Associate Professor, Department of Computer Science, Ponnaiyah Ramajayam Institute of Science and Technology, Tamil Nadu, India.

Cluster Analysis

Cluster analysis is a statistical method for processing data. It works by organizing items into groups – or clusters – based on how closely associated they are.

Cluster analysis is an unsupervised learning algorithm, meaning that you don't know how many clusters exist in the data before running the model. Unlike many other statistical methods, cluster analysis is typically used when there is no assumption made about the likely relationships within the data. It provides information about where associations and patterns in data exist, but not what those might be or what they mean.

When should cluster analysis be used?

Cluster analysis is for when you're looking to segment or categories a dataset into groups based on similarities, but aren't sure what those groups should be.

While it's tempting to use cluster analysis in many different research projects, it's important to know when it's genuinely the right fit. Here are three of the most common scenarios where cluster analysis proves its worth.

Exploratory data analysis

When you have a new dataset and are in the early stages of understanding it, cluster analysis can provide a much-needed guide.

By forming clusters, you can get a read on potential patterns or trends that could warrant deeper investigation.

Market segmentation

This is a golden application for cluster analysis, especially in the business world. Because when you aim to target your products or services more effectively, understanding your customer base becomes paramount.

Cluster analysis can carve out specific customer segments based on buying habits, preferences or demographics, allowing for tailored marketing strategies that resonate more deeply.

CHAPTER 5

EXPLORING CLUSTER ANALYSIS: METHODS, AND APPLICATIONS

R. RAJAYOGESWARI

Assistant Professor, Department of Computer Science, Ponnaiyah Ramajayam Institute of Science and Technology, Tamil Nadu, India.

Cluster analysis, also known as clustering, is a method of data mining that groups similar data points together. The goal of cluster analysis is to divide a dataset into groups (or clusters) such that the data points within each group are more similar to each other than to data points in other groups. This process is often used for exploratory data analysis and can help identify patterns or relationships within the data that may not be immediately obvious. There are many different algorithms used for cluster analysis, such as k-means, hierarchical clustering, and density-based clustering. The choice of algorithm will depend on the specific requirements of the analysis and the nature of the data being analyzed.

Cluster Analysis is the process to find similar groups of objects in order to form clusters. It is an unsupervised machine learning-based algorithm that acts on unlabeled data. A group of data points would comprise together to form a cluster in which all the objects would belong to the same group.

The given data is divided into different groups by combining similar objects into a group. This group is nothing but a cluster. A cluster is nothing but a collection of similar data which is grouped together.

Properties of Clustering:

1. Clustering Scalability: Nowadays there is a vast amount of data and should be dealing with huge databases. In order to handle extensive databases, the clustering algorithm should be scalable. Data should be scalable, if it is not scalable, then we can't get the appropriate result which would lead to wrong results.

2. High Dimensionality: The algorithm should be able to handle high dimensional space along with the data of small size.

3. Algorithm Usability with multiple data kinds: Different kinds of data can be used with algorithms of clustering. It should be capable of dealing with different types of data like discrete, categorical and interval-based data, binary data etc.

4. Dealing with unstructured data: There would be some databases that contain missing values, and noisy or erroneous data. If the algorithms are sensitive to such data then it may lead to poor quality clusters. So it should be able to handle unstructured data and give some structure to the data by organizing it into groups of similar data objects. This makes the job of the data expert easier in order to process the data and discover new patterns.

5. Interpretability: The clustering outcomes should be interpretable, comprehensible, and usable. The interpretability reflects how easily the data is understood.

CHAPTER 6

WEB DATA MINING: TECHNIQUES

K.PRIYADHARSHINI

Assistant Professor, Department of Computer Science, Ponnaiyah Ramajayam Institute of Science and Technology, Tamil Nadu, India.

Web data mining became an easy and important platform for retrieval of useful information. Users prefer World Wide Web more to upload and download data. As increasing growth of data over the internet, it is getting difficult and time consuming for discovering informative knowledge and patterns. Digging knowledgeable and user queried information from unstructured and inconsistent data over the web is not an easy task to perform.

Different mining techniques are used to fetch relevant information from web (hyperlinks, contents, web usage logs). Web data mining is a sub discipline of data mining which mainly deals with web. Web data mining is divided into three different types: web structure, web content and web usage mining. All these types use different techniques, tools, approaches, algorithms for discover information from huge bulks of data over the web.

It is must to manage that massive information and display most related queried information on user's screen. Analyzing and fetching relevant data from large data bases is not possible manually, for this automated extraction tools are required through which user queried data can be fetch from billions of pages over the internet and discovers relevant information. Usually users find data from world wild web WWW by using different search engines like Yahoo, Bing, MSN, Google etc.

Data mining is a process of analyzing usable information and extract data from large data warehouses, involving different patterns, intelligent methods, algorithms and tools. This process can help business to analyze data, user behavior and predict future trends. Data mining includes four strategies steps for relevant data extraction.

Data source is a set on data in large data base which can have problem definition in it. Data exploration is a step of investigation true information from bulks of unfamiliar data. Third step is modeling, in this different models are designed and then evaluate. At the end tested models are deployed, that occurs in final step of data mining strategies. Organizations can use data mining techniques to change raw data into convenient information. It can also help business to improve their marketing strategies and increase the profit by learning more about customer's behavior.

Web mining is one of the types of techniques use in data mining. The main purpose of web mining is to automatically extract information from the web. For discovering useful data (videos, tables, audio, images etc.) from the web different techniques and tools are used. Information over the internet is huge and increasing with passage to time due to which size of data bases are also growing.

CHAPTER 7

WEB DATA MINING: TOOLS FOR EXTRACTING INSIGHTS FROM THE WEB

G.GAYATHRI

Assistant Professor, Department of Computer Science, Ponnaiyah Ramajayam Institute of Science and Technology, Tamil Nadu, India.

Data mining is a process of discovering knowledge from data warehouse. This knowledge can be classified in different rules and patterns that can help user/organization to analyze collective data and predicted decision processes. Centralized database of any organization is known as Data warehouse, where all data is stored in a single huge database.

Data mining is a method that is used by organization to get useful information from raw data. Software's are implemented to look for needed patterns in huge amount of data (data warehouse) that can help business to learn about their customers, predict behavior and improve marketing strategies.

Web Mining Categories

Web Mining is sub categorized in to three types

- A. Web Content Mining
- B. Web Structure Mining
- C. Web Usage Mining

Data cleaning is not only important for usage mining but important for other analysis techniques as well. Purpose is to remove irrelevant and no needed information from logs. Graphics and videos needs to be removed from web logs as they are unnecessary for usage mining. When user requests for a web server for a particular web page, multiple entries are stored in log file. Those records that are not useful for usage mining must be removed.

User and Session identification technique is used to find user sessions from access log file. After data cleaning next step is to identify users. Different approaches are used for user identification like user login information, cookies to detect visitors with unique ID for specific webpage. Session identification is to know number of pages visited by a single user in a row on one visit to a website.

Data mining is a concept that helps to find information which is needed from large data warehouses by using different techniques. It is also used to analyze past data and improve future strategies. Web data mining is considered as sub approach of data mining that focuses on gathering information from web.



WAP AND XML

EDITED BY
G.BIRIYATHARSHINI



978-93-6255-388-5

WAP and XML

Copyright ©2023

By
G.BIRIYATHARSHINI

All rights reserved. No part of this book may be reproduced or transmitted in any form or by any means without written permission from the author.

ISBN: 978-93-6255-380-5

Publisher: Ponnaiyah Ramajayam Institute of Science and technology

TABLE OF CONTENTS

| | | |
|-------------------------------|--|-----|
| CHAPTER 1 P.KARTHIK | Exploring the World of WAP: Architecture and Development | I |
| CHAPTER 2 K.PRIYADHARSHINI | Exploring the World of WAP: Deployment Top of Form | II |
| CHAPTER 3 H.PARVEENBEGUM | Navigating the WAP Landscape: Gateways & WML Basics | III |
| CHAPTER 4 R.RAJAYOGESHWARI | Navigating the WAP Landscape: Network Positioning | IV |
| CHAPTER 5 P.SAKILA | Maximizing User Engagement: WML Scripting | V |
| CHAPTER 6 R.KALAISELVI | Maximizing User Engagement: Error Management in WAP | VI |
| CHAPTER 7 G.GAYATHRI | Unveiling XML: From Introduction to Structuring Data | VII |

CHAPTER-1

WAP and XML

P.KARTHIK

*Assistant Professor Department of Computer Science
PRIST University, Thanjavur*

Introduction

Wireless Application Protocol (WAP) is a technical standard that enables mobile devices to access information and services over a wireless network. It was designed to create a standardized protocol for mobile internet access, particularly when devices and networks were constrained by bandwidth, memory, and processing power.

WAP

Architecture

WAP's architecture can be understood as a layered protocol stack that is similar to the Internet's protocol stack, but optimized for the mobile environment. Below is a breakdown of the key layers in WAP:

- 1. WAP Gateway**
 - Acts as a bridge between the mobile device and the web.
 - Translates web content (HTML) to WAP content (WML - Wireless Markup Language) and vice versa.
 - Handles communication between wireless networks and the internet.
- 2. WAE (Wireless Application Environment)**
 - Analogous to the Application Layer in the OSI model.
 - Defines how web applications are accessed and interacted with on mobile devices.
 - Includes WML (a lightweight markup language similar to HTML) and WMLScript (a scripting language similar to JavaScript).
- 3. WSP (Wireless Session Protocol)**
 - Functions similarly to HTTP but is optimized for wireless devices.
 - Handles session management, enabling more efficient connections for mobile devices.
- 4. WTLS (Wireless Transport Layer Security)**
 - Ensures secure communication between devices and servers by encrypting data and maintaining data integrity.
 - A mobile-optimized version of SSL/TLS used on the web.
- 5. WTP (Wireless Transaction Protocol)**
 - Provides a lightweight, connection-oriented, transaction-based service, optimizing data transfers.
 - Ensures error recovery, data acknowledgment, and retransmission in cases of network failure.
- 6. WDP (Wireless Datagram Protocol)**
 - Similar to UDP on the internet.
 - Offers basic datagram services and is responsible for data transmission between the WAP device and the WAP gateway.
- 7. Bearer Networks**
 - The lowest layer in the architecture, responsible for physical transmission of data.

CHAPTER-2

WAP and XML

K.PRIYADHARSHINI

*Assistant Professor Department of Computer Science
PRIST University, Thanjavur*

Introduction

Deployment in the context of Wireless Application Protocol (WAP) refers to the process of making a WAP-based mobile application available to users. Given the constraints of early mobile devices, deploying WAP applications required careful planning, optimization, and leveraging network infrastructure, including WAP gateways, to deliver content effectively to mobile phones.

WAP Deployment Architecture

WAP deployment involves several key components and steps to ensure mobile users can access WAP applications seamlessly. Below is the typical flow in the deployment process:

1. Client Devices (Mobile Phones)

- Users access WAP applications from mobile devices that support WAP browsers (such as Nokia, Ericsson, and Motorola phones).
- The mobile phone must be configured with the appropriate access settings provided by the mobile operator, including WAP Gateway IP, port, and network access points.

2. WAP Gateway

- A critical part of WAP deployment is the **WAP Gateway**, which acts as a bridge between mobile devices and the internet.
- The WAP gateway performs several important functions:
 - **Protocol Translation:** Converts WML (Wireless Markup Language) from the server into binary form (WBXML) to reduce data size, making it easier for mobile devices to handle.
 - **Optimization:** Compresses and optimizes content for mobile devices that have limited bandwidth, memory, and processing power.
 - **Session Management:** Manages the communication sessions between mobile devices and servers.
- The WAP gateway also handles security and encryption (via WTLS) to ensure secure data transmission.

3. WAP Server

- The WAP server is responsible for hosting the WAP content and applications, similar to how a web server hosts web content.
- WML pages, WBMP images, and WMLScript are hosted on this server, where they are accessed by mobile users via the WAP gateway.
- The WAP server can also interface with backend services like databases, application servers, and other APIs to provide dynamic content.

CHAPTER-3

WAP and XML

H PARVEENBEGUM

*Assistant Professor Department of Computer Science
PRIST University, Thanjavur*

Introduction

The Wireless Application Protocol (WAP) opened up the world of mobile internet, enabling access to online services from early mobile devices with limited capabilities. A critical part of this ecosystem is the **WAP Gateway**, which acts as the bridge between mobile phones and the internet, translating data between the two systems. Alongside this, **Wireless Markup Language (WML)** was introduced to serve as the primary language for developing mobile-friendly content optimized for the restricted bandwidth, memory, and processing power of early mobile devices.

WAP Gateway: The Bridge Between Mobile Devices and the Web

A WAP Gateway is an essential component in the WAP architecture. It acts as an intermediary between mobile devices and content hosted on the web, translating requests and responses between the two systems. Here's how it works:

Key Functions of the WAP Gateway

1. Protocol Translation

- WAP-enabled devices communicate using WAP protocols (e.g., WSP, WTP), while web servers communicate using HTTP.
- The gateway translates WAP requests (from mobile devices) into HTTP requests and translates HTTP responses (from web servers) into WAP responses (such as WML or WBXML).

2. Data Optimization

- Mobile devices often have limited bandwidth, memory, and display capabilities.
- The gateway compresses and optimizes data, converting WML (Wireless Markup Language) into WBXML (WAP Binary XML) for more efficient transmission to mobile devices.

3. Security

- The WAP gateway provides a layer of security through **WTLS (Wireless Transport Layer Security)**, a version of SSL/TLS optimized for mobile devices.
- It ensures secure communication between the mobile device and the WAP server, encrypting data and maintaining data integrity.

4. Session Management

- It manages and maintains sessions between the mobile device and the web server. This is crucial for ensuring consistent communication over networks that may suffer from latency or connection drops.

5. Device Profiling

CHAPTER-4

WAP and XML

R.RAJAYOGESHWARI

*Assistant Professor Department of Computer Science
PRIST University, Thanjavur*

Introduction

Wireless Application Protocol (WAP) was designed to facilitate access to internet services on mobile devices, which were constrained by limited processing power, memory, and network bandwidth. **Network positioning** in the WAP architecture plays a crucial role in determining how efficiently data is transmitted between mobile devices and web servers. It involves optimizing the way mobile devices interact with the WAP gateway, bearer networks, and the internet to deliver services effectively despite mobile network limitations.

In this context, network positioning refers to the strategic placement of WAP gateways, the optimization of mobile data transfer, and the use of bearer networks to improve data delivery and service quality.

Key Components in WAP Network Positioning

1. Mobile Devices

- Mobile devices access WAP applications via WAP browsers, which send requests using mobile networks.
- Early WAP devices included basic feature phones that operated over low-bandwidth networks such as GSM and CDMA.
- Modern smartphones also incorporate WAP, though it has largely been replaced by more advanced technologies such as HTTP over 4G or 5G networks.

2. Bearer Networks

- Bearer networks refer to the underlying wireless infrastructure (such as GSM, GPRS, EDGE, or CDMA) that facilitates communication between the mobile device and the WAP gateway.
- The type of bearer network directly affects the speed and reliability of the data connection.
 - **GSM:** Offers circuit-switched voice and data services at very low speeds (up to 14.4 kbps).
 - **GPRS:** Introduced packet-switched data transmission, providing higher speeds than GSM.
 - **EDGE:** Enhanced GPRS, allowing for faster data speeds (up to 384 kbps).
 - **3G/4G:** Later generations of mobile networks that significantly improved data rates for both WAP and non-WAP traffic.
- The choice of bearer network influences the overall user experience, especially when dealing with WAP applications that need to operate under bandwidth and latency constraints.

CHAPTER-5

WAP and XML

P.SAKILA

*Assistant Professor Department of Computer Science
PRIST University, Thanjavur*

Introduction

Wireless Markup Language (WML) is the markup language designed specifically for mobile devices in the early days of mobile internet, providing a way to create lightweight web pages for small screens. To increase interactivity and enhance user engagement, **WMLScript** was introduced as an extension of WML, similar to how JavaScript complements HTML. WMLScript allows developers to execute client-side scripts, manage user input, validate forms, and control navigation, creating a more dynamic and responsive user experience.

Maximizing user engagement with WML and WMLScript is essential when working with mobile devices that have limited resources. By using these tools, developers can make mobile web applications more interactive, efficient, and user-friendly.

What is WML Script?

WMLScript is the scripting language designed to work with WML to provide client-side logic. It is a lightweight scripting language, optimized for mobile devices with limited processing power and memory. WMLScript allows developers to:

- Perform form validation before submitting data to the server.
- Handle user events such as clicks or form submissions.
- Display dynamic content or responses based on user input.
- Reduce network traffic by handling simple tasks on the client side rather than making frequent server requests.

Key Features of WMLScript

1. Light weight Design

WMLScript is designed to be highly efficient, consuming minimal bandwidth and system resources. This makes it suitable for mobile devices with limited capabilities.

2. Client-Side Validation

One of the most common uses of WMLScript is to validate user input locally, ensuring that invalid data does not need to be transmitted to the server. This saves bandwidth and reduces the load on the server.

3. Event Handling

WMLScript can respond to various user interactions, such as button clicks or form submissions. This enables dynamic responses to user actions, similar to JavaScript in traditional web applications.

4. Control of Navigation

WMLScript allows developers to control the flow of a WML application by

CHAPTER-6

WAP and XML

R.KALAISELVI

*Assistant Professor Department of Computer Science
PRIST University, Thanjavur*

Introduction

Wireless Application Protocol (WAP) was designed for mobile devices with limited resources, including small screens, low processing power, and slow network speeds. Given these constraints, error management plays a crucial role in ensuring a smooth user experience. Errors can occur due to various reasons, including network issues, user input errors, and device limitations. In the context of WAP, effective error management not only minimizes user frustration but also helps maintain engagement by providing clear, actionable feedback and preventing disruptions.

Error management in WAP involves handling issues gracefully through proper feedback, user-friendly messages, and preventing application crashes. This is where Wireless Markup Language (WML) and WMLScript come into play, as they allow developers to design WAP applications that handle errors dynamically and keep users engaged, even in adverse conditions.

Types of Errors in WAP Applications

WAP applications face several types of errors that must be managed effectively:

1. Network Errors

- Due to slow or unstable network connections, requests may fail to reach the server, or responses may not be delivered. WAP applications should be able to detect and recover from such failures.
- **Timeout errors** and **connection errors** are common in mobile networks with limited bandwidth.

2. User Input Errors

- Users may provide incorrect or incomplete data in forms (e.g., missing required fields, invalid email addresses). Input validation errors need to be caught before the data is sent to the server, reducing the likelihood of server-side errors.

3. Device-Specific Errors

- WAP applications must account for different device capabilities, including screen size, processing power, and memory limitations. Errors can occur when content is not rendered properly or when devices fail to process larger files.

4. Application Logic Errors

- Errors related to how the WAP application is coded, such as incorrect logic in WMLScript or navigation errors in WML. These must be caught and handled to avoid application crashes or confusing behavior.

CHAPTER-7

WAP and XML

G.GAYATHRI

*Assistant Professor Department of Computer Science
PRIST University, Thanjavur*

Introduction to XML

XML, or Extensible Markup Language, is a versatile and widely-used markup language designed for storing and transporting data. Unlike HTML, which focuses on presenting data, XML is all about structuring and defining the data itself. With its platform-independent nature and human-readable format, XML has become a foundational technology for data interchange in various applications, ranging from web services to configuration files.

The Purpose of XML

The primary goal of XML is to facilitate the sharing of structured data across different systems, particularly over the internet. Its flexibility allows developers to define custom tags that can represent complex data structures. This makes XML an ideal choice for applications that require data to be easily exchanged, stored, and processed.

1.2 Key Features of XML

Extensibility

XML is inherently extensible. Users can create their own tags that suit their data needs, allowing for the representation of virtually any kind of information. This capability is what sets XML apart from other data formats.

Self-Descriptive Structure

An XML document is self-descriptive, meaning that the tags used in the document convey meaningful information about the data. This self-documenting nature enhances understanding and usability, making it easier for both humans and machines to interpret the data.

Platform Independence

XML is platform-independent, meaning it can be utilized across different systems and technologies. Whether you are using Java, Python, or .NET, XML can serve as a common format for data exchange, facilitating interoperability.

Hierarchical Structure

XML uses a tree-like structure to represent data, allowing for nested elements. This hierarchical organization is beneficial for modeling complex relationships within the data, making it easier to navigate and manipulate.



MICROPROCESSORS AND MICROCONTROLLERS LAB MANUAL

Edited by

E.PRIYADHARSHINI



978-93-6255-591-5

MICROPROCESSORS AND MICROCONTROLLERS LAB MANUAL

COPYRIGHT @ 2023 BY E.PRIYADHARSHINI

ALL RIGHTS RESERVED. NO PART OF THIS BOOK MAY BE
REPRODUCED OR TRANSMITTED IN ANY FORM OR BY ANY MEANS
WITHOUT WRITTEN PERMISSION FROM THE AUTHOR.

ISBN: 978-93-6255-591-5

PUBLISHER: Ponnaiyah Ramajayam Institute of Science and Technology
(PRIST)

EX.NO.1. PROGRAMS FOR BASIC ARITHMETIC AND LOGICAL OPERATIONS (USING 8086)

AIM:

To write an assembly language program to perform arithmetic operations using 8086 Microprocessor.

ALGORITHM:-

a) Addition:-

- (i) Start the process
- (ii) Initialize the count value
- (iii) Get the two data.
- (iv) Add the two data values
- (v) If carry exists increment the count value.
- (vi) Store the result.
- (vii) Stop the process.

PROGRAM

| Label | Address | Mnemonics | | Hex code | Comments |
|--------|---------|-----------|------------|----------------|---|
| | | Opcode | Operand | | |
| | 1000 | MOV | CL , 00 | C6, C1, 00 | ; Initialize the count |
| | 1003 | MOV | AX, 0F0C | C7, C0, 0C, 0F | ; Move1 st data to accumulator |
| | 1007 | MOV | BX, 111F | C7, C3, 1F, 11 | ; Move2 nd data to register |
| | 100B | ADD | BX, AX | 01, C3 | ; Add the two data |
| | 100D | JNC | LOOP1 | 73, 02 | ; Jump on no carry |
| | 100F | INC | CL | FE, C1 | ; Increment the counter |
| LOOP1: | 1011 | MOV | [1100], BX | 89,1E, 00, 11 | ; Store the result |
| | 1015 | MOV | [1102], CL | 88, 0E, 02,11 | ; Store the carry |
| | 1019 | HLT | | F4 | ; Stop the process |

OUTPUT

16 – BIT ADDITION

| Address | Output |
|---------|--------|
| 1100 | 2B |
| 1101 | 20 |
| 1102 | 00 |

16 BIT ADDITION

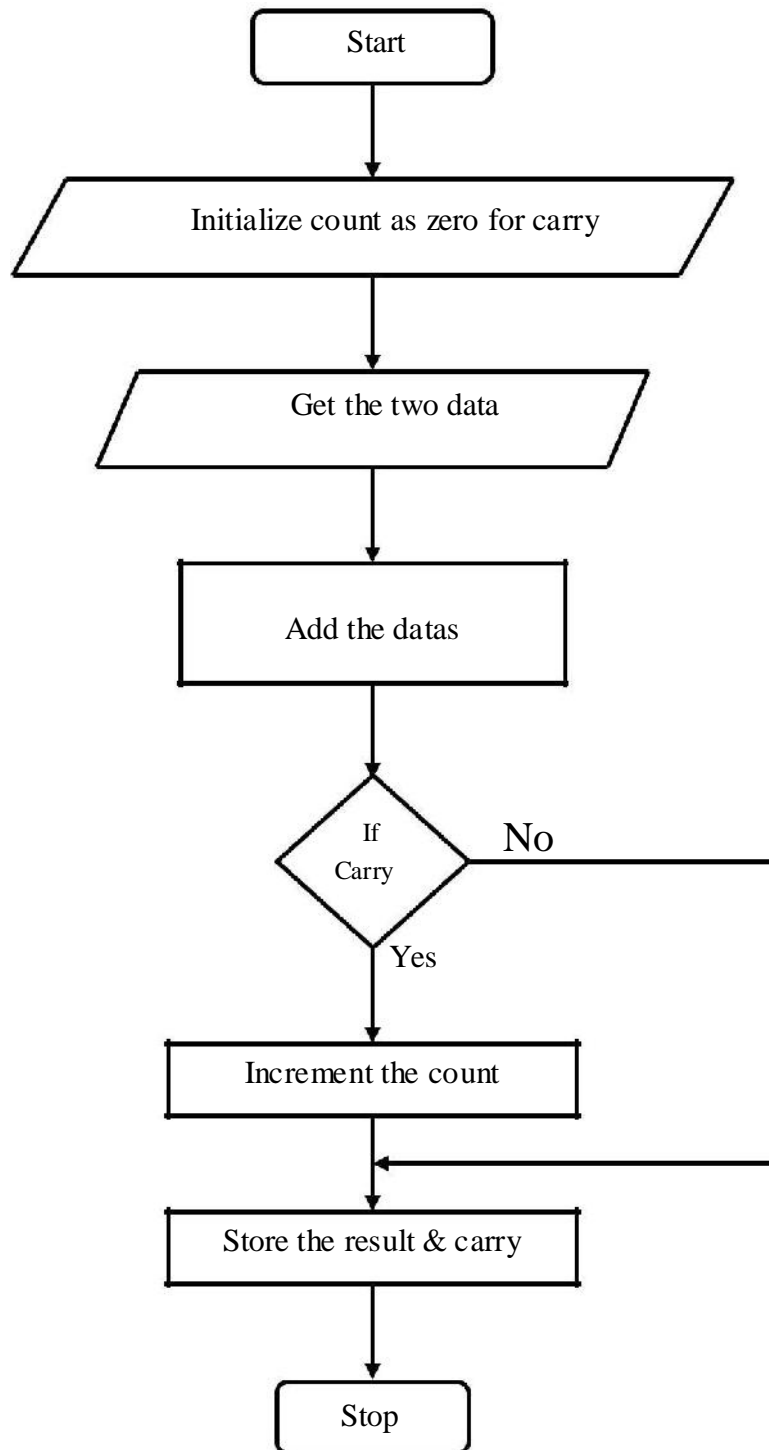

1 B) 16 BIT SUBTRACTION

ALGORITHM:-

- (i) Start the process
- (ii) Initialize the count value
- (iii) Get the two data and subtract it.
- (iv) If carry exists, get the 2's complement of the value.
- (v) Store the result and carry value.
- (vi) Stop the process.

PROGRAM

| Label | Address | Mnemonics | | Hex code | Comments |
|--------|---------|-----------|------------|----------------|---|
| | | Opcode | Operand | | |
| | 1000 | MOV | CL, 00 | C6, C1, 00 | ; Initialize the count |
| | 1003 | MOV | AX, [1100] | 8B, 06, 00, 11 | ; Move 1 st data to accumulator |
| | 1007 | MOV | BX, [1102] | 8B, 1E, 02, 11 | ; Move 2 nd data to 'B' register |
| | 100B | SUB | BX, AX | 29, C3 | ; Subtract the two datas |
| | 100D | JNC | LOOP1 | 73, 05 | ; Jump on no carry |
| | 100F | INC | CL | FE, C1 | ; Increment the counter |
| | 1011 | NOT | BX | F7, D3 | ; Get the complement value |
| | 1013 | INC | BX | 43 | ; Increment the value |
| LOOP1: | 1014 | MOV | [1104], BX | 89, 1E, 04, 11 | ; Store the result |
| | 1018 | MOV | [1106], CL | 88, 0E, 06, 11 | ; Store the carry |
| | 101C | HLT | | F4 | ; Stop the process |

OUTPUT

16 – BIT SUBTRACTION

| Address | Input |
|---------|-------|
| 1100 | 76 |
| 1101 | 86 |
| 1102 | 45 |
| 1103 | 81 |

| Address | Output |
|---------|--------|
| 1104 | 31 |
| 1105 | 65 |
| 1106 | 00 |

FLOWCHART:-

Subtraction:-

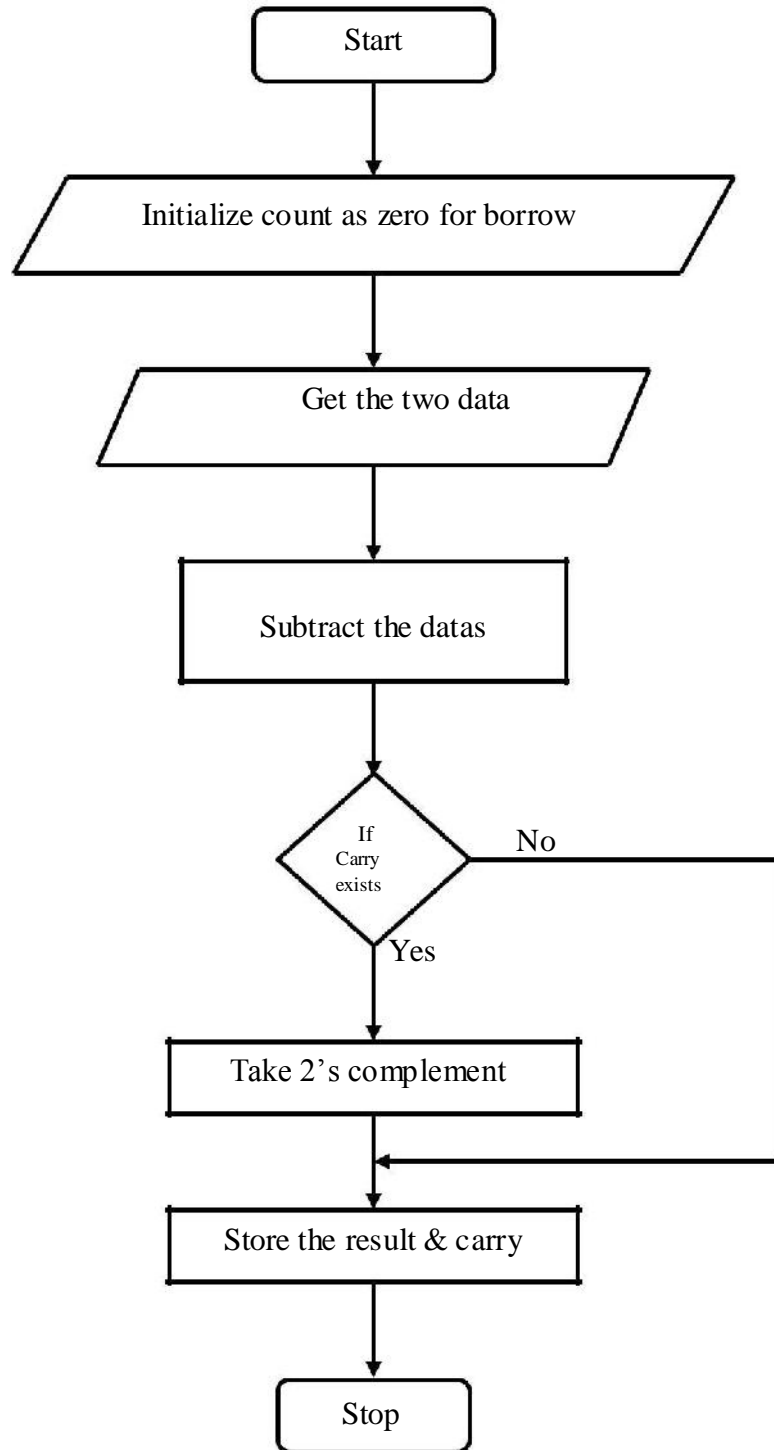

1.C) 16 BIT MULTIPLICATION

ALGORITHM:-

- (i) Start the process
- (ii) Get the two values
- (iii) Multiply the two values.
- (iv) Store the result and overflow
- (v) Stop the process.

PROGRAM

| Label | Address | Mnemonics | | Hex code | Comments |
|-------|---------|-----------|------------------|---------------|---|
| | | Opcode | Operand | | |
| | 1000 | MOV | SI, 1100 | C7, C6,00, 11 | ; Move the source index |
| | 1004 | MOV | AX, [SI] | 8B, 04 | value |
| | 1006 | MOV | BX, [SI + 02] | 8B, 54, 02 | ; Move the first data |
| | 1009 | MUL | BX | F7, E3 | ; Get the second data |
| | 100B | MOV | [SI + 04], | 89, 44, 04 | ; Multiply the data |
| | 100E | MOV | AX | 89, 54, 0b | ; Store the result |
| | 1011 | HLT | [SI + 06], DX | F4 | ; Store the over flow ; Stop the process |

INPUT

| Address | Input |
|---------|-------|
| 1100 | 11 |
| 1101 | 11 |
| 1102 | 00 |
| 1103 | 11 |

OUTPUT

| Address | Output |
|---------|--------|
| 1104 | 00 |
| 1105 | 21 |
| 1106 | 22 |
| 1107 | 01 |

FLOW CHART:-

Multiplication:-

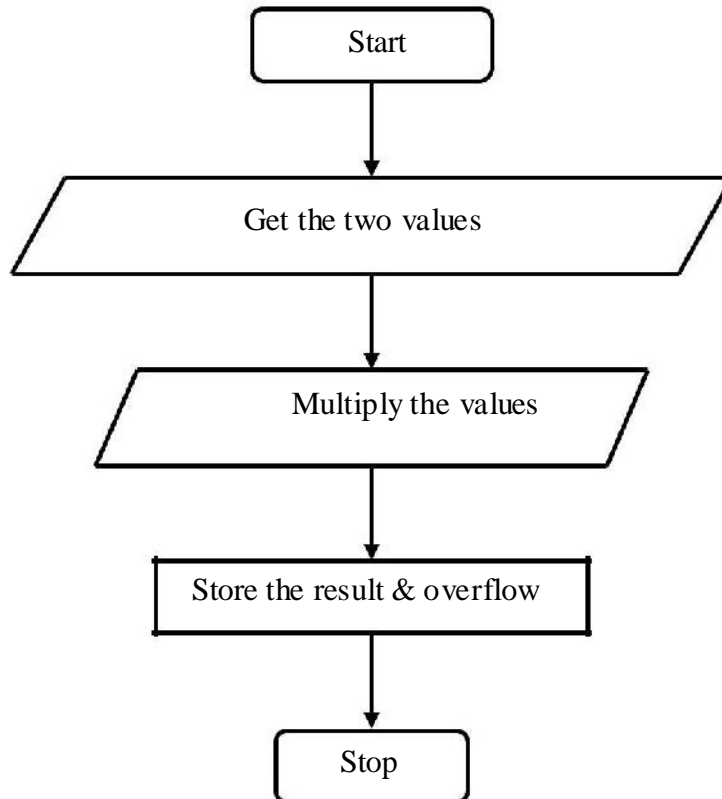

D) 16 BIT DIVISION

AIM:

To perform division of a 32 bit number by a 16 bit number and store the quotient and remainder in memory

ALGORITHM:-

- (i) Start the process
- (ii) Get the two values
- (iii) Initialize 'DX' register as zero
- (iv) Divide the values
- (v) Store the quotient and remainder
- (vi) Stop the process.

FLOWCHART:

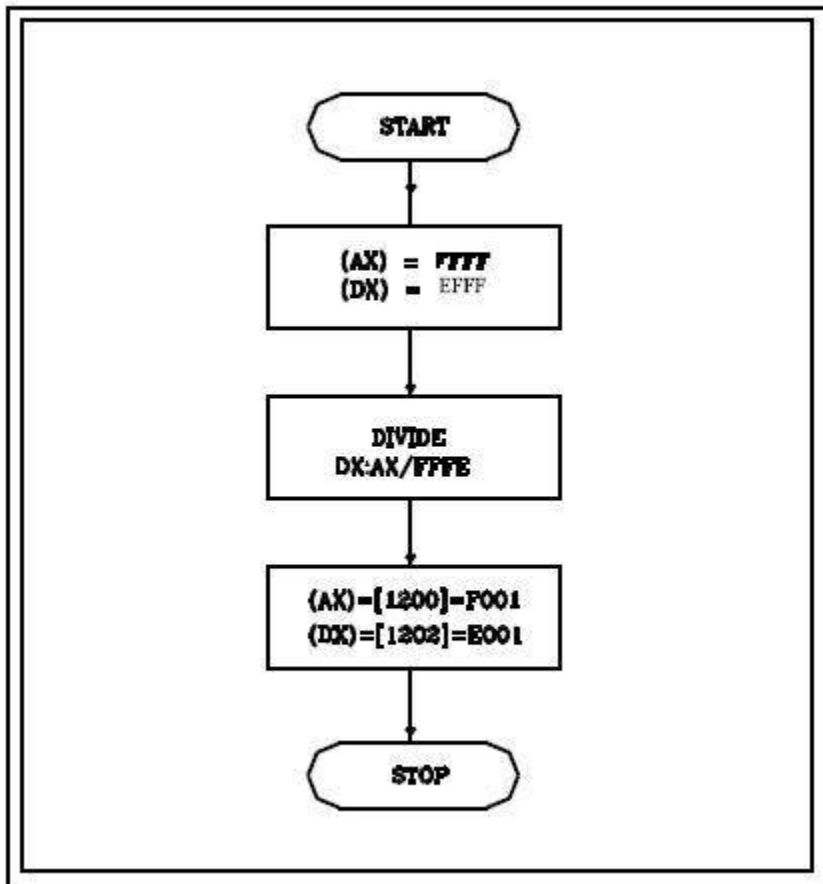

D) 16 BIT DIVISION

PROGRAM

| Label | Address | Mnemonics | | Hex code | Comments |
|-------|---------|-----------|---------------|----------------|------------------------------|
| | | Opcode | Operand | | |
| | 1000 | MOV | SI, 1100 | C7, C6, 00, 11 | ; Get the source index value |
| | 1004 | MOV | Ax, [SI] | 8B, 04 | ; Get the first data |
| | 1006 | MOV | DX, [SI + | 8B, 54, 02 | ; Initialize 'DX' register |
| | 1009 | MOV | 02] | 8B, 5C, 04 | value |
| | 100C | DIV | BX, [SI + 04] | F7, E3 | ; Get the dividend value |
| | 100E | MOV | BX | 89, 44, 06 | ; Divide the value |
| | 1011 | MOV | [SI + 06], | 89, 54, 08 | ; Move the quotient |
| | 1014 | HLT | AX | F4 | ; Move the remainder & store |
| | | | [SI + 08], | | ; Stop the process |
| | | | DX | | |

16 – BIT DIVISION

| Address | Input |
|---------|---------------|
| 1100 | 42 (DIVIDEND) |
| 1101 | 24 |
| 1102 | 00 |
| 1103 | 00 |
| 1104 | 02 (DIVISOR) |
| 1105 | 00 |

| Address | Output |
|---------|----------------|
| 1106 | 21 (QUOTIENT) |
| 1107 | 12 |
| 1108 | 00 (REMAINDER) |
| 1109 | 00 |

RESULT:-

Thus the assembly language program for 16 Bit Arithmetic and Logical operations has been done and verified.

VIVA QUESTIONS AND ANSWERS

1. What is a Microprocessor?

Microprocessor is a CPU fabricated on a single chip, program-controlled device, which fetches the instructions from memory, decodes and executes the instructions.

2. What is Instruction Set?

It is the set of the instructions that the Microprocessor can execute.

3. What is Clock Speed?

Clock speed is measured in the MHz and it determines that how many instructions a processor can processed. The speed of the microprocessor is measured in the MHz or GHz.

4. What are the features of Intel 8086?

Features:

Released by Intel in 1978

Produced from 1978 to 1990s

A 16-bit microprocessor chip.

Max. CPU clock rate: 5 MHz to 10 MHz

Instruction set: x86-16

5. What are the flags in 8086?

In 8086 carry flag, Parity flag, Auxiliary carry flag, Zero flag, Overflow flag, Trace flag, Interrupt flag, Direction flag, and Sign flag.

6. What is assembly language?

The language in which the mnemonics (short -hand form of instructions) are used to write a program is called assembly language. The manufacturers of microprocessor give the mnemonics.

7. What are machine language and assembly language programs?

The software developed using 1's and 0's are called machine language, programs. The software developed using mnemonics are called assembly language programs.

8. What is the drawback in machine language and assembly language, programs?

The machine language and assembly language programs are machine dependent. The programs developed using these languages for a particular machine cannot be directly run on another machine.

9. Define bit, byte and word.

A digit of the binary number or code is called bit. Also, the bit is the fundamental storage unit of computer memory.

The 8-bit (8-digit) binary number or code is called byte and 16-bit binary number or code is called word. (Some microprocessor manufactures refer the basic data size operated by the processor as word).

10. What is a bus?

Bus is a group of conducting lines that carries data, address and control signals.

2. PROGRAM FOR SEARCHING AND SORTING OF AN ARRAY USING 8086

2a. SORTING AN ARRAY IN ASCENDING ORDER

AIM:-

Write an assembly language program to sort an array of data in ascending order.

ALGORITHM:-

1. Set SI register as pointer for array.
2. Set CL register as count for $N - 1$ repetitions.
3. Initialize array pointer.
4. Set CH as count for $N - 1$ comparisons.
5. Increment the array pointer.
6. Get an element of array AL register.
7. Increment the array pointer.
8. Compare the next element of the array with AL.
9. Checks carry flag. If carry flag is set then go to step -12, otherwise go to next step.
10. Exchange the content of memory pointed by SI and the content of previous memory location
11. Decrement the count for comparisons (CH register).
12. Check zero flag. If zero flag is reset then go to step-6, otherwise go to next step.
13. Decrement the count for repetitions (CL register).
14. Check zero flag. If zero flag is reset then go to step-3, otherwise go to next step.
15. Stop.

SORTING IN ASCENDING ORDER

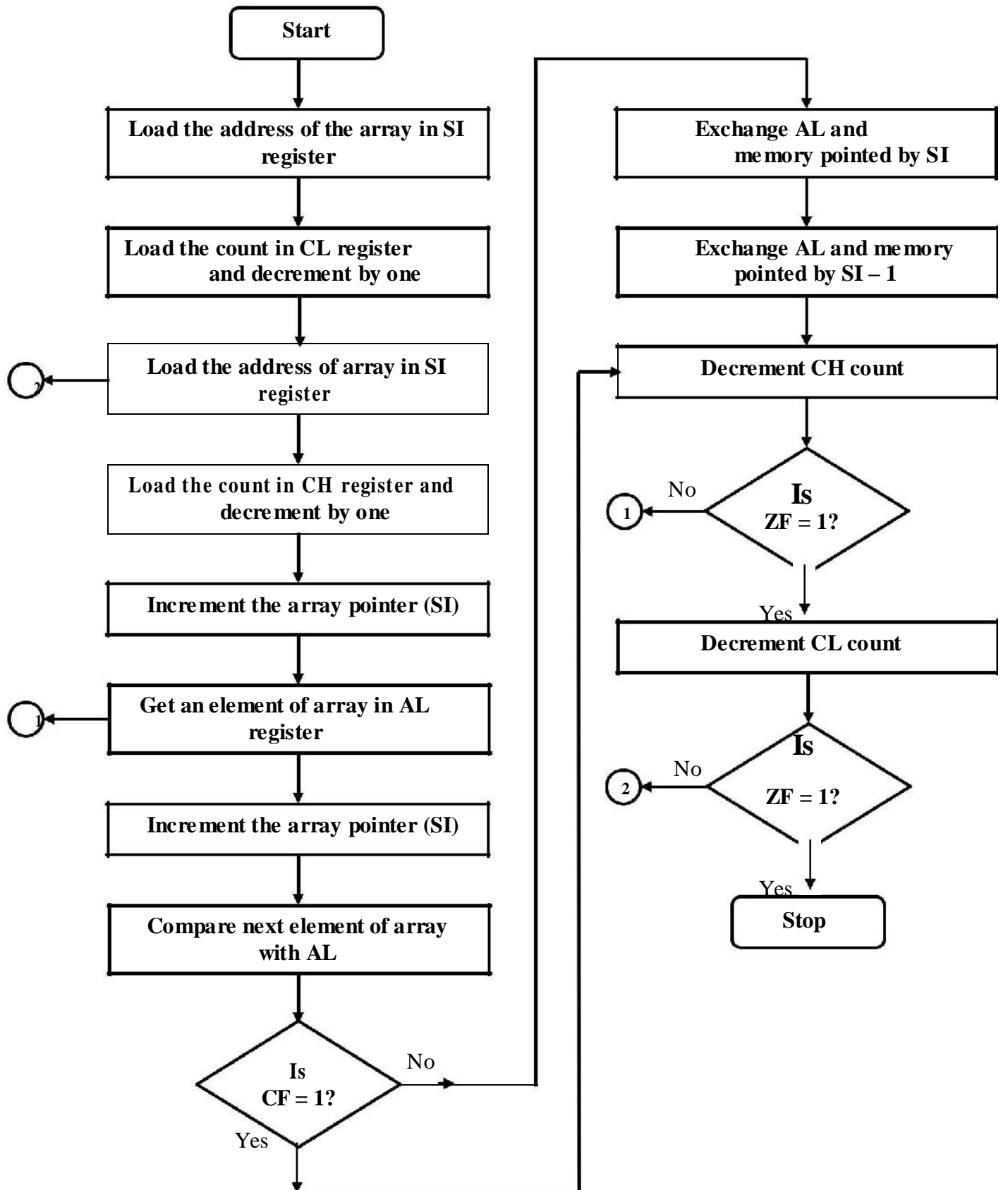

PROGRAM

| Label | Address | Mnemonics | | Hex code | Comments |
|--------|---------|-----------|--------------|-------------|---|
| | | Opcode | Operand | | |
| START: | 1000 | MOV | SI, 1100H | C7 C6 00 11 | ; Set SI register as pointer for array |
| | 1004 | MOV | CL, [SI] | 8A 0C | ; Set CL as count for N – 1 repetitions |
| | 1006 | DEC | CL | FE C9 | |
| REPEAT | 1008 | MOV | SI, 1100H | C7 C6 00 11 | ; Initialize pointer |
| | 100C | MOV | CH, [SI] | 8A 2C | ; Set CH as count for N – 1 comparisons |
| | 100E | DEC | CH | FE CD | |
| | 1010 | INC | SI | 46 | ; Decrement the count |
| REPCOM | 1011 | MOV | AL, [SI] | 8A 04 | ; Get an element of array in AL register |
| | 1013 | INC | SI | 46 | |
| | 1014 | CMP | AL, [SI] | 3A 04 | ; Compare with next element of array ; in memory |
| | 1016 | JC | AHEAD | 72 05 | ; If AL register is lesser than memory, ‘then go to AHEAD |
| | 1018 | XCHG | AL, [SI] | 86 04 | ; If AL is less than memory then ; exchange |
| | 101A | XCHG | AL, [SI – 1] | 86 44 FF | ; the content of memory pointed by ; SI and the previous memory location |
| AHEAD | 101D | DEC | CH | FE CD | ; Decrement the count for comparisons |
| | 101F | JNZ | REPCOM | 75 F0 | ; Repeat comparisons until CH count is ; zero |
| | 1021 | DEC | CL | FE C9 | ; Decrement the count for repetitions |
| | 1023 | JNZ | REPEAT | 75 E3 | ; Repeat N – 1 comparisons until CL count is zero |
| | 1025 | HLT | | F4 | |

| Address | Input |
|---------|------------|
| 1100 | 05 – count |
| 1101 | 09 |
| 1102 | 49 |
| 1103 | 24 |
| 1104 | 32 |
| 1105 | 64 |

| Address | Output |
|---------|------------|
| 1100 | 05 – count |
| 1101 | 09 |
| 1102 | 24 |
| 1103 | 32 |
| 1104 | 49 |
| 1105 | 64 |

RESULT:

Thus the assembly language program to sort an array of data in ascending order using 8086 has been done and verify successfully.

b. SORTING AN ARRAY IN DESCENDING ORDER

AIM:-

Write an assembly language program to sort an array of data in descending order.

ALGORITHM:-

1. Set SI register as pointer for array.
2. Set CL register as count for $N - 1$ repetitions.
3. Initialize array pointer.
4. Set CH as count for $N - 1$ comparisons.
5. Increment the array pointer.
6. Get an element of array AL register.
7. Increment the array pointer.
8. Compare the next element of the array with AL.
9. Checks carry flag. If carry flag is set then go to step -12, otherwise go to next step.
10. Exchange the content of memory pointed by SI and the content of previous memory location
(For this, exchange AL and memory pointed by SI, and then exchange AL and memory pointed
SI - I).
11. Decrement the count for comparisons (CH register).
12. Check zero flag. If zero flag is reset then go to step-6, otherwise go to next step.
13. Decrement the count for repetitions' (CL register).
14. Check zero flag. If zero flag is reset then go to step-3, otherwise go to next step.
15. Stop.

SORTING IN DESCENDING ORDER

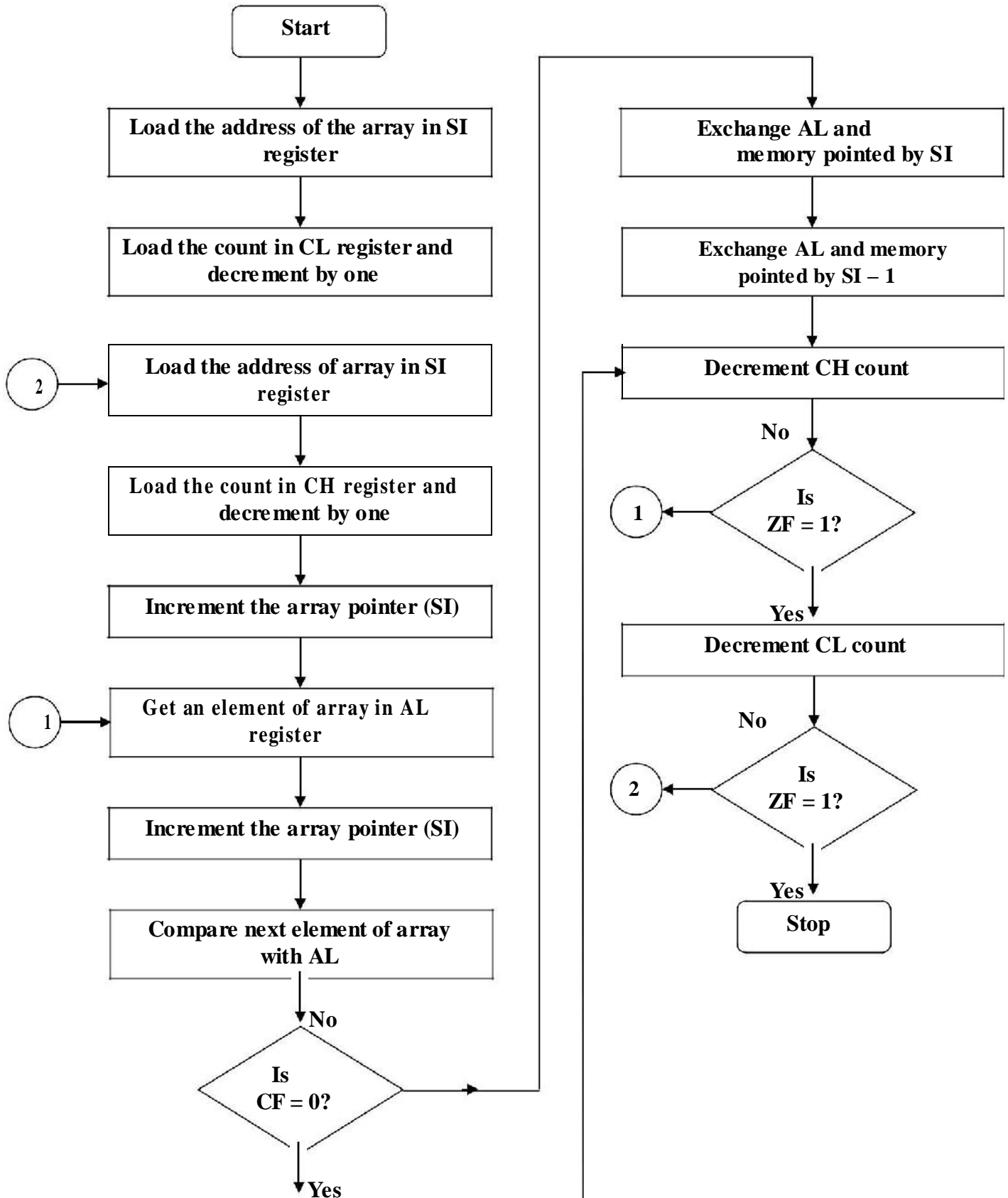

PROGRAM

| Label | Address | Mnemonics | | Hex code | Comments |
|--------|---------|-----------|--------------|-------------|---|
| | | Opcode | Operand | | |
| START: | 1000 | MOV | SI, 1100H | C7 C6 00 11 | ; Set SI register as pointer for array |
| | 1004 | MOV | CL, [SI] | 8A 0C | ; Set CL as count for N – 1 repetitions |
| | 1006 | DEC | CL | FE C9 | |
| REPEAT | 1008 | MOV | SI, 1100H | C7 C6 00 11 | ; Initialize pointer |
| | 100C | MOV | CH, [SI] | 8A 2C | ; Set CH as count for N – 1 comparisons |
| | 100E | DEC | CH | FE CD | |
| | 1010 | INC | SI | 46 | ; Increment the count |
| REPCOM | 1011 | MOV | AL, [SI] | 8A 04 | ; Get an element of array in AL register |
| | 1013 | INC | SI | 46 | |
| | 1014 | CMP | AL, [SI] | 3A 04 | ; Compare with next element of array |
| | 1016 | JNC | AHEAD | 73 05 | ; in memory ; It AL is greater than memory, then go ; to AHEAD |
| | 1018 | XCHG | AL, [SI] | 86 04 | ; If AL is less than memory then |
| | 101A | XCHG | AL, [SI – 1] | 86 44 FF | ; exchange the content of memory ; pointed by SI and the previous memory ; location |
| AHEAD | 101D | DEC | CH | FE CD | ; Decrement the count for comparisons |
| | 101F | JNZ | REPCOM | 75 F0 | ; Repeat comparisons until CH count is zero |
| | 1021 | DEC | CL | FE C9 | ; Decrement the count for repetitions |
| | 1023 | JNZ | REPEAT | 75 E3 | ; Repeat N – 1 comparisons until CL count is zero |
| | 1025 | HLT | | F4 | |

| Address | Input |
|---------|------------|
| 1100 | 05 – count |
| 1101 | 09 |
| 1102 | 49 |
| 1103 | 24 |
| 1104 | 32 |
| 1105 | 64 |

| Address | Output |
|---------|------------|
| 1100 | 05 – count |
| 1101 | 64 |
| 1102 | 49 |
| 1103 | 32 |
| 1104 | 24 |
| 1105 | 09 |

RESULT:

Thus the assembly language program to sort an array of data in descending order using 8086 has been done and verify successfully.

2 C . SEARCHING FOR SMALLEST NUMBER IN AN ARRAY

AIM:-

Write an assembly language program to search the smallest data in an array.

ALGORITHM:

1. Load the starting address of the array in SI register.
2. Load the address of the result in DI register.
3. Load the number of bytes in the array in CL register.
4. Increment the array pointer (SI register).
5. Get the first byte of the array in AL register
6. Decrement the byte count (CL register).
7. Increment the array pointer (SI register).
8. Get next byte of the array in BL register.
9. Compare current smallest (AL) and next byte (BL) if the array.
10. Check carry flag. If carry flag is set then go to step -12, otherwise go to next step.
11. Move BL to AL.
12. Decrement the byte count (CL register).
13. Check zero flag. If zero flag is reset then go to step-7, otherwise go to next step.
14. Save the smallest data in memory pointed by DI.
15. Stop.

FLOWCHART

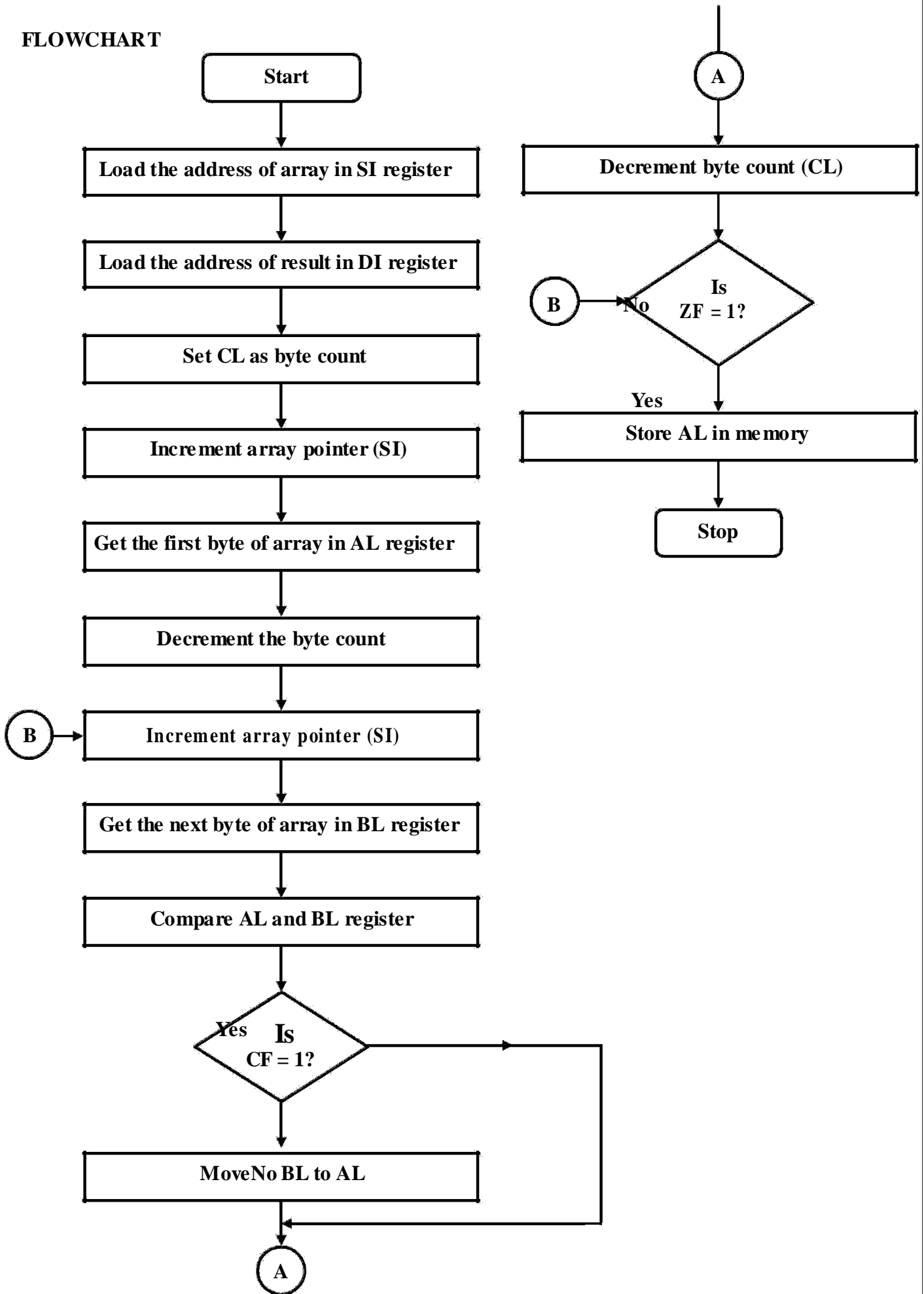

PROGRAM

| Label | Address | Mnemonics | | Hex code | Comments |
|-------|---------|-----------|-----------|-------------|---|
| | | Opcode | Operand | | |
| START | 1000 | MOV | SI, 1100H | C7 C6 00 11 | ; Set SI register as pointer for array |
| | 1004 | MOV | DI, 1200H | C7 C7 00 12 | ; Set DI register as pointer for result |
| | 1008 | MOV | CL, [SI] | 8A 0C | ; Set CL as count for elements in the array |
| | 100A | INC | SI | 46 | ; Increment the address pointer |
| | 100B | MOV | AL, [SI] | 8A 04 | ; Set first data as smallest |
| AGAIN | 100D | DEC | CL | FE C9 | ; Decrement the count |
| | 100F | INC | SI | 46 | ; Make SI to point to next data in array |
| | 1010 | MOV | BL, [SI] | 8A 1C | ; Get the next data in BL register |
| | 1012 | CMP | AL, BL | 38 D8 | ; Compare current smallest data in AL ; with BL |
| | 1014 | JC | AHEAD | 72 02 | ; If carry is set then AL is less than BL ; hence proceed to AHEAD |
| AHEAD | 1016 | MOV | AL, BL | 88 D8 | ; If carry is not set then make BL as ; current smallest |
| | 1018 | DEC | CL | FE C9 | ; Decrement the count |
| | 101A | JNZ | AGAIN | 75 F3 | ; If count is not zero repeat search |
| | 101C | MOV | [DI], AL | 88 05 | ; Store the smallest data in memory |
| | 101E | HLT | | F4 | |

Smallest no in the array

| Address | Input |
|---------|------------|
| 1100 | (05) count |
| 1101 | 22 |
| 1102 | AA |
| 1103 | FF |
| 1104 | 45 |
| 1105 | 50 |
| Address | Output |
| 200 | 22 |

RESULT:

Thus the assembly language program for smallest data in an array using 8086 has been done and verify successfully.

2D). SEARCHING FOR LARGEST NUMBER IN AN ARRAY

AIM:-

Write an assembly language program to search the largest data in an array.

ALGORITHM:

1. Load the starting address of the array in SI register.
2. Load the address of the result in DI register.
3. Load the number of bytes in the array in CL register.
4. Increment the array pointer (SI register).
5. Get the first byte of the array in AL register
6. Decrement the byte count (CL register).
7. Increment the array pointer (SI register).
8. Get next byte of the array in BL register.
9. Compare current smallest (AL) and next byte (BL) if the array.
10. Checks carry flag. If carry flag is set then go to step -12, otherwise go to next step.
11. Move BL to AL.
12. Decrement the byte count (CL register).
13. Check zero flag. If zero flag is reset then go to step-7, otherwise go to next step.
14. Save the largest data in memory pointed by DI.
15. Stop.

FLOWCHART:

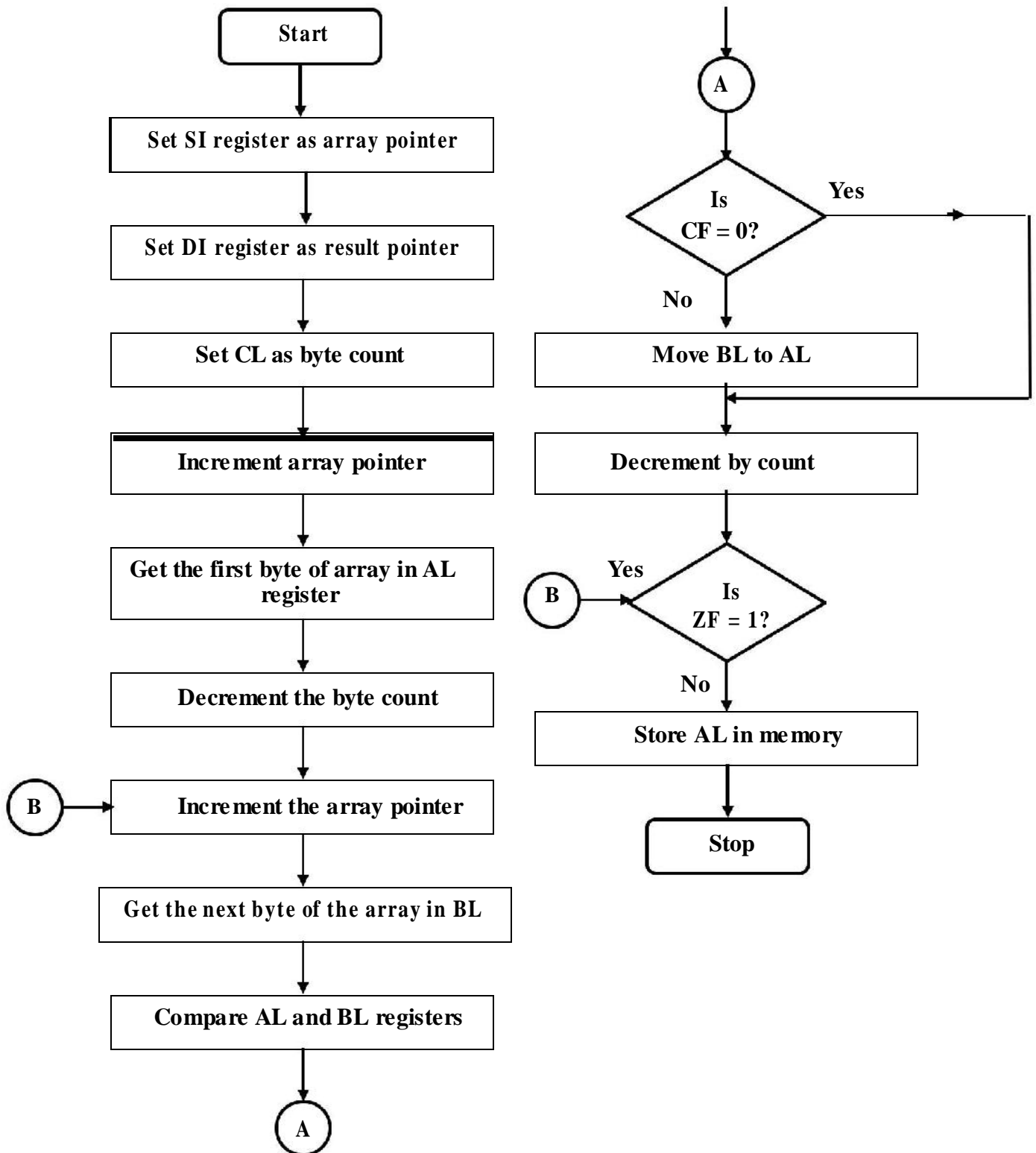

PROGRAM

| Label | Address | Mnemonics | | Hex code | Comments |
|-------|---------|-----------|-----------|-------------|---|
| | | Opcode | Operand | | |
| START | 1000 | MOV | SI, 1100H | C7 C6 00 11 | ; Set SI register as pointer for array |
| | 1004 | MOV | DI, 1200H | C7 C7 00 12 | ; Set DI register as pointer for result |
| | 1008 | MOV | CL, [SI] | 8A 0C | ; Set CL as count for elements in the ; array |
| | 100A | INC | SI | 46 | ; Increment the address pointer |
| | 100B | MOV | AL, [SI] | 8A 04 | ; Set first data as smallest |
| AGAIN | 100D | DEC | CL | FE C9 | ; Decrement the count |
| | 100F | INC | SI | 46 | ; Make SI to point to next data in array |
| | 1010 | MOV | BL, [SI] | 8A 1C | ; Get the next data in BL register |
| | 1012 | CMP | AL, BL | 38 D8 | ; Compare current smallest data in AL ; with BL |
| | 1014 | JNC | AHEAD | 73 02 | ; If carry is set then AL is less than BL ; hence proceed to AHEAD |
| AHEAD | 1016 | MOV | AL, BL | 88 D8 | ; If carry is not set then make BL as ; current largest |
| | 1018 | DEC | CL | FE C9 | ; Decrement the count |
| | 101A | JNZ | AGAIN | 75 F3 | ; If count is not zero repeat search |
| | 101C | MOV | [DI], AL | 88 05 | ; Store the smallest data in memory |
| | 101E | HLT | | F4 | |

Largest

| Address | Input |
|---------|------------|
| 1100 | 05 – count |
| 1101 | 22 |
| 1102 | AA |
| 1103 | FF |
| 1104 | 45 |
| 1105 | 50 |
| Address | Output |
| 1200 | FF |

RESULT:

Thus the assembly language program for largest data in an array using 8086 has been done and verify successfully.

VIVA QUESTIONS AND ANSWERS

1. What are the different types of Addressing Modes?

The different types of Addressing Modes are

Immediate, Direct, Register, Register Indirect, Indexed, Register Relative addressing modes

2. What are Data Copy/Transfer Instructions?

A:- Mov, Push, Pop, Xchg, In, Out, Xlat, Lea, Lds/Les, Lahf, Sahf, Pushf, Popf

3. What are Machine Control Instructions?

A:- Nop, Hlt, Wait, Lock

4) What are Flag Manipulation Instructions?

A:- Cld, Std, Cli, Sti

5) What are String Instructions?

A:- Rep, MovSB/MovSW, Cmps, Scas, Lods, Stos

6. Why data bus is bi-directional?

The microprocessor has to fetch (read) the data from memory or input device for processing and after processing, it has to store (write) the data to memory or output device. Hence the data bus is bi-directional.

7. Why address bus is unidirectional?

The address is an identification number used by the microprocessor to identify or access a memory location or I / O device. It is an output signal from the processor. Hence the address bus is unidirectional.

8. What is the function of microprocessor in a system?

The microprocessor is the master in the system, which controls all the activity of the system. It issues address and control signals and fetches the instruction and data from memory. Then it executes the instruction to take appropriate action.

3. PROGRAM FOR STRING MANIPULATION OPERATIONS USING 8086

AIM:-

To write a program for string manipulation such as fill a byte, move a string; compare the string by using 8086 microprocessor kit.

ALGORITHM:

a) Move the string:

Step1: Start the process

Step2: Initialize the memory

Step3: Clear the direction flag

Step4: Move the value to string

Step5: Stop the process

b) Compare the string: Step1:

Start the process

Step2: Initialize the counter and carry value

Step3: Initialize the memory value

Step4: Compare two values

Step5: If the two value are equal set the carry otherwise reset

Step6: Stop the process

c) Fill a Byte:

Step1: Start the process

Step2: Clear the direction flag

Step3: Initialize the counter

Step4: Get the value of byte

Step5: Initialize the memory

Step6: Store the value in memory

Step7: Stop the process

Move the String:

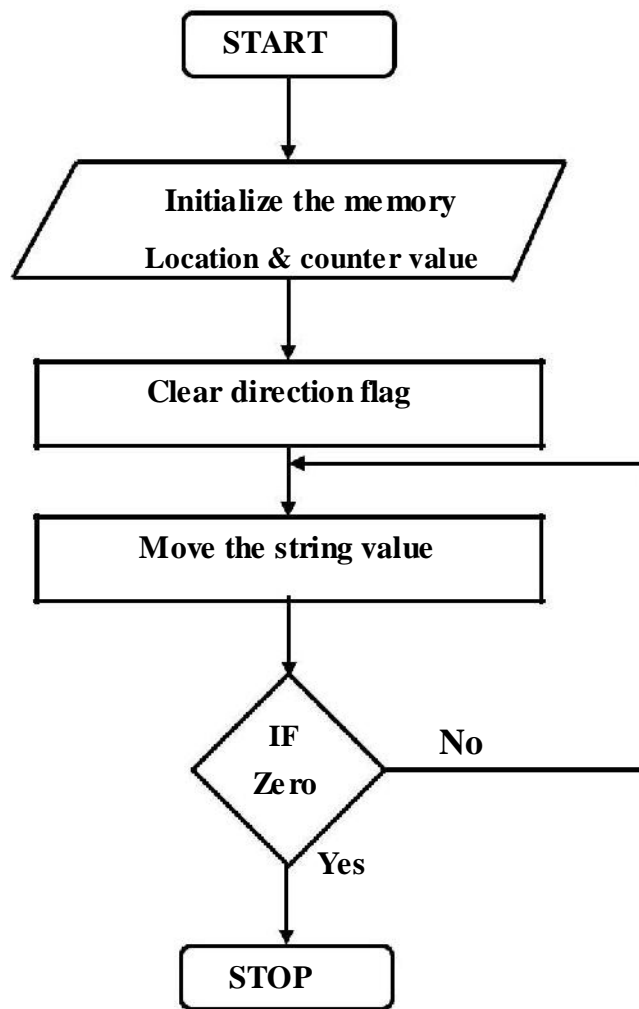

3a) Move the String:

PROGRAM:

| Label | Address | Mnemonics | | Hex code | Comments |
|--------|---------|-----------|---------|----------------|----------------------------|
| | | Opcode | Operand | | |
| LOOP1: | 1000 | MOV | SI,1100 | C7, C6, 00, 11 | Initialize the memory |
| | 1004 | MOV | DI,1200 | C7, C7, 00, 12 | Initialize the memory |
| | 1008 | MOV | CX,0005 | C7, C1, 05, 00 | Initialize the counter |
| | 100C | CLD | | FC | Clear the direction flag |
| | 100D | MOVSB | | A4 | Store the result of string |
| | 100E | LOOP | LOOP1 | E2, FD | Go to LOOP L1 |
| | 1010 | HLT | | F4 | Stop the process. |

Observation:

| Address | Input |
|---------|-------|
| 1100 | 11 |
| 1101 | 22 |
| 1102 | 33 |
| 1103 | 44 |
| 1104 | 55 |

| Address | Output |
|---------|--------|
| 1200 | 11 |
| 1201 | 22 |
| 1202 | 33 |
| 1203 | 44 |
| 1204 | 55 |

Compare the String:

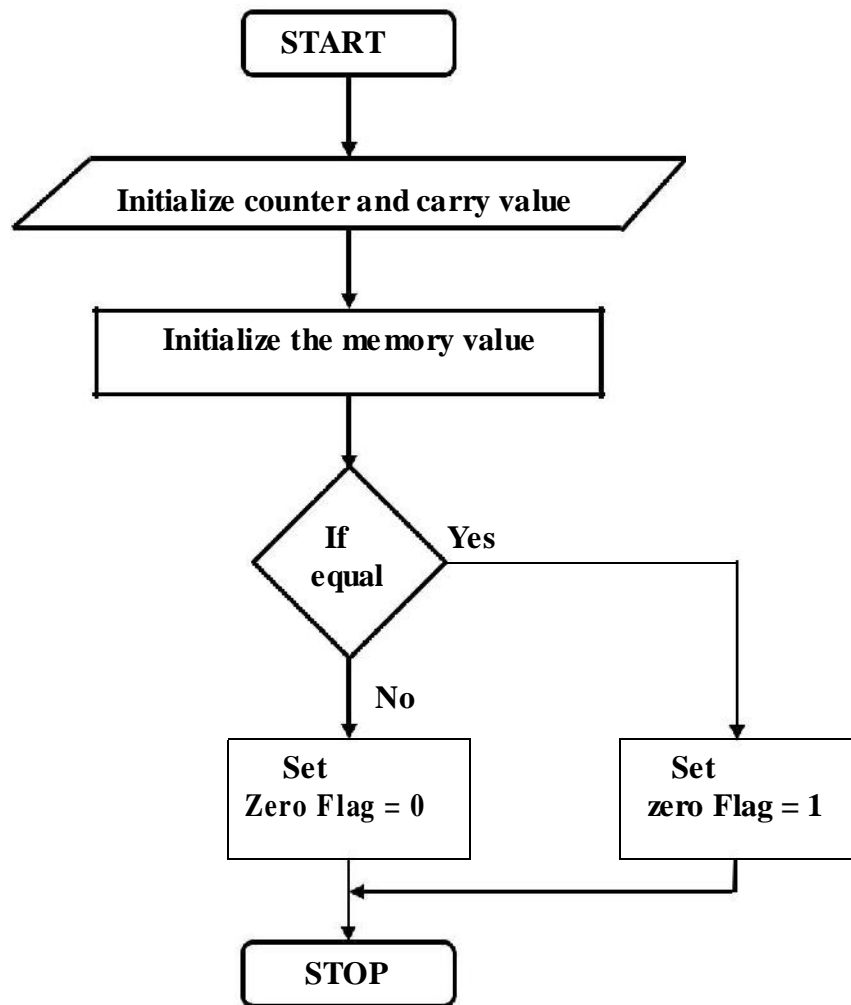

3b) Compare the String:

PROGRAM

| Label | Address | Mnemonics | | Hex code | Comments |
|--------|---------|-----------|------------|----------------|--------------------------|
| | | Opcode | Operand | | |
| | 1000 | CLD | | FC | Clear the direction flag |
| | 1001 | MOV | DX,0000 | C7, C2, 00, 00 | Initialize the carry |
| | 1005 | MOV | CX,0005 | C7, C1, 05, 00 | Initialize the counter |
| | 1009 | MOV | SI,1200 | C7, C6, 00, 12 | |
| | 100D | MOV | DI,1300 | C7, C7, 00, 13 | Initialize the memory |
| | 1011 | REPZ | CMPSB | F3, A6 | Compare the string |
| | 1013 | JNZ | LOOP1 | 75, 01 | If no zero to L1 |
| | 1015 | INC | DX | 42 | Increment DX value. |
| LOOP1: | 1016 | MOV | [1400], DX | 89, 16, 00, 14 | Move the value in memory |
| | 101A | HLT | | F4 | Stop the process |

| Address | Input |
|---------|-------|
| 1200 | 11 |
| 1201 | 12 |
| 1202 | 13 |
| 1203 | 14 |
| 1204 | 15 |

| Address | Input |
|---------|-------|
| 1300 | 11 |
| 1301 | 12 |
| 1302 | 13 |
| 1303 | 14 |
| 1304 | 15 |

| Address | Output |
|---------|--------|
| 1400 | 01 |
| 1401 | 00 |

Fill a Byte:

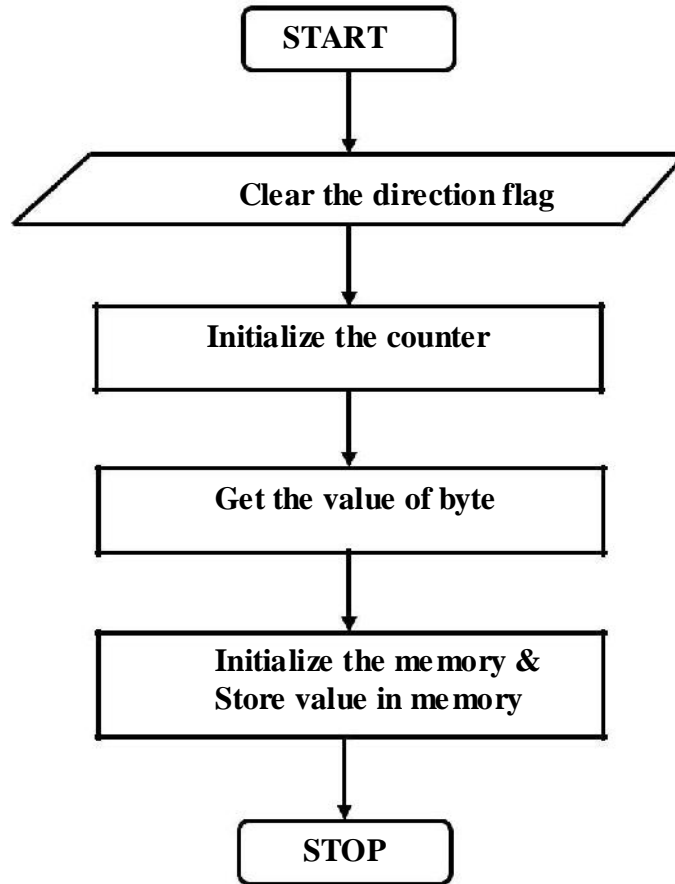

3c) Fill a Byte

PROGRAM

| Label | Address | Mnemonics | | Hex code | Comments |
|--------|---------|-----------|----------|----------------|--------------------------|
| | | Opcode | Operand | | |
| LOOP1: | 1000 | CLD | | FC | Clear the direction flag |
| | 1001 | MOV | DX, 0005 | C7, C2, 05, 00 | Initialize the counter |
| | 1005 | MOV | AL, 1F | C6, C0, 1F | Get the value of byte |
| | 1008 | MOV | DI, 1200 | C7, C7, 00, 12 | Initialize the memory |
| | 100C | STOSB | | AA | Store the value |
| | 100D | LOOP | LOOP1 | E2, FD | Loop L1 |
| | 100F | HLT | | F4 | Stop the process |

| Address | Input |
|---------|-------|
| 1200 | 1F |
| 1201 | 1F |
| 1202 | 1F |
| 1203 | 1F |
| 1204 | 1F |

| Address | Output |
|---------|--------|
| 1200 | 1F |
| 1201 | 1F |
| 1202 | 1F |
| 1203 | 1F |
| 1204 | 1F |

RESULT:

Thus the operation of string manipulation is done and verified using 8086 microprocessor.

VIVA QUESTIONS AND ANSWERS

1. Explain the difference between a JMP and CALL instruction?

A JMP instruction permanently changes the program counter.

A CALL instruction leaves information on the stack so that the original program execution sequence can be resumed.

2. What is Assembler?

The assembler translates the assembly language program text which is given as input to the assembler to their binary equivalents known as object code.

3. What is the use of HLDA?

HLDA is the acknowledgment signal for HOLD. It indicates whether the HOLD signal is received or not.

HOLD and HLDA are used as the control signals for DMA operations.

4. Explain about "LEA"?

LEA(Load Effective Address) is used for initializing a register with an offset address.

A common use for LEA is to initialize an offset in BX, DI or SI for indexing an address in memory.

5. Difference between "Shift" and "Rotate".

Shift and Rotate commands are used to convert a number to another form where some bits are shifted or rotated.

A rotate instruction is a closed loop instruction. That is, the data moved out at one end is put back in at the other end.

6. What are the modes in which 8086 can operate?

The 8086 can operate in two modes and they are minimum (or uniprocessor) mode and maximum (or multiprocessor) mode.

7. What is the data and address size in 8086?

The 8086 can operate on either 8-bit or 16-bit data. The 8086 uses 20 bit address to access memory and 16-bit address to access I/O devices.

8. Explain the function of M/IO in 8086.

The signal M/IO is used to differentiate memory address and I/O address. When the processor is accessing memory locations M/IO is asserted high and when it is accessing I/O mapped devices it is asserted low.

4. CODE CONVERSION, DECIMAL ARITHMETIC AND MATRIX OPERATIONS

4a) Hexadecimal to Decimal code conversion

Aim:

To write an assembly language program to convert hexadecimal number into decimal number

Algorithm:

1. Load the number to be converted into the accumulator.
2. If the number is less than 100 (64H), go to next step; otherwise, subtract 100 (64H) repeatedly until the remainder is less than 100 (64H). Have the count(100's value) in separate register which is the carry.
3. If the number is less than 10 (0AH), go to next step; otherwise, subtract 10 (0AH) repeatedly until the remainder is less than 10 (0AH). Have the count(ten's value) in separate register.
4. The accumulator now has the units.
5. Multiply the ten's value by 10 and add it with the units.
6. Store the result and carry in the specified memory location.

FLOWCHART:

Hexadecimal to Decimal conversion

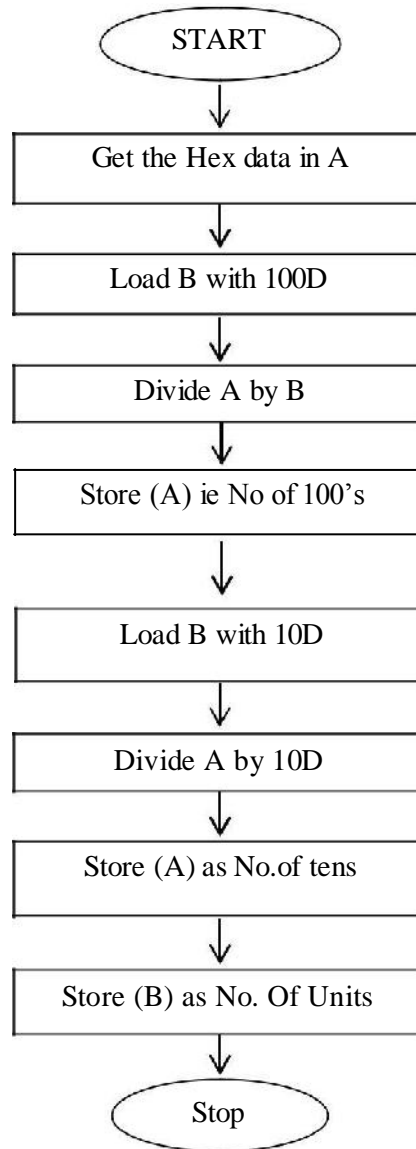

PROGRAM

| Label | Address | Mnemonics | | Hex code | Comments |
|-------|---------|-----------|------------|-------------|---|
| | | Opcode | Operand | | |
| START | 1000 | MOV | SI,1100 | C7 C6 00 11 | ; Load the input address 1100 |
| | 1004 | MOV | DX,00 00 | C7 C2 00 00 | ; Load address in SI |
| | 1008 | MOV | AX,[SI] | 8B 04 | ; Load 64 to Count the number of 100s |
| | 100A | MOV | BX,00 64 | C7 C3 64 00 | ;Get the number of hundreds |
| | 100E | DIV | BX | F7 F3 | ; Load number of hundreds in1102 & 1103 |
| | 1010 | MOV | [SI+02],AX | 89 44 02 | ; Move the remainder to AX |
| | 1013 | MOV | AX,DX | 89 D0 | ; Initialize DX with 0000 |
| | 1015 | MOV | DX ,00 00 | C7 C2 00 00 | ; Load 0A to find number of tens |
| | 1019 | MOV | BX, 00 0A | C7 C3 0A 00 | ; Divide by 0A to get number of tens |
| | 101D | DIV | BX | F7 F3 | ; Move no of tens to the address 1104 & 1105 |
| | 101F | MOV | [SI+04],AX | 89 44 04 | ; Move no of ones to the address 1106 & 1107 |
| | 1022 | MOV | [SI+06],DX | 89 54 06 | ; Halt |
| | 1025 | HLT | | F4 | |

| Address | Input |
|-------------|-----------|
| 1100 | FF |
| 1101 | 00 |

| Address | Output |
|-------------|-----------|
| 1102 | 02 |
| 1103 | 00 |
| 1104 | 05 |
| 1105 | 00 |
| 1106 | 05 |
| 1107 | 00 |

MATRIX OPERATION

FLOW CHART:

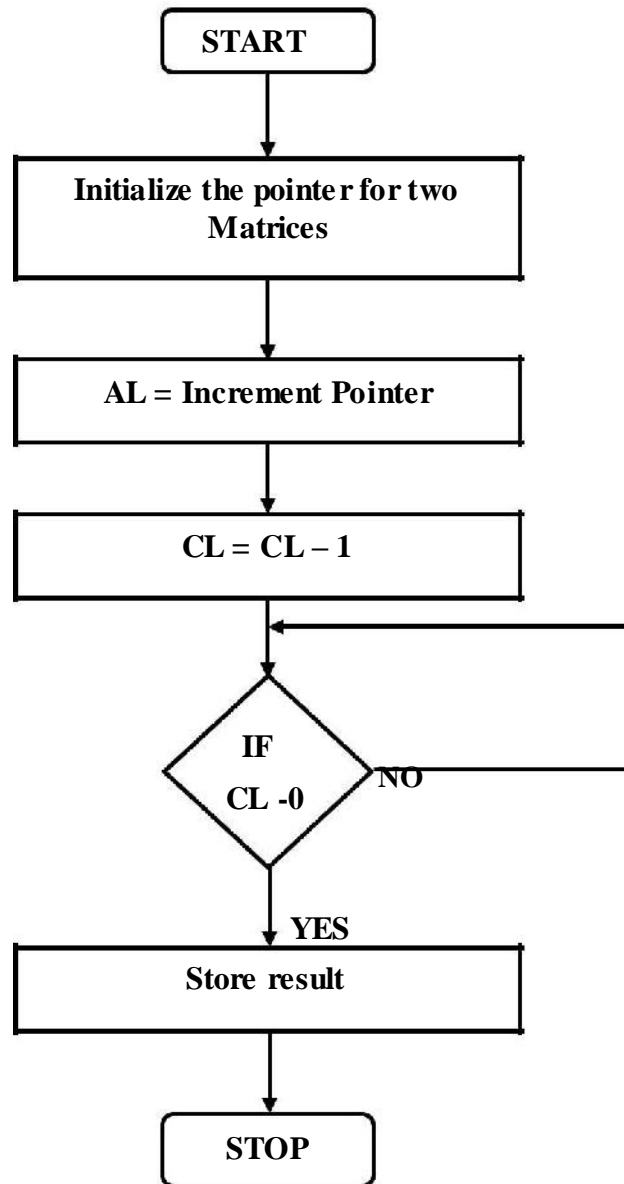

4b. MATRIX OPERATIONS USING 8086

AIM:

To write a program for addition of two 3x3 matrix by using 8086.

ALGORITHM:

1. Initialize the pointer only for data and result
2. Load AL with count
3. Add two matrix by each element
4. Process continues until CL is zero
5. Store result.

PROGRAM

| Label | Address | Mnemonics | | Hex code | Comments |
|-------|---------|-----------|---------|-------------|-----------------------------|
| | | Opcode | Operand | | |
| START | 1000 | MOV | CL,09 | C6 C1 09 | ;count for 3 x 3 matrix |
| | 1003 | MOV | SI,1200 | C7 C6 00 12 | ; address in SI |
| LOOP | 1007 | MOV | DI,1300 | C7 C7 00 13 | ; address in DI |
| | 100B | MOV | AL,[SI] | 8A 04 | ;Load AL with matrix |
| | 100D | MOV | BL,[DI] | 8A 1D | ; Load BL with matrix |
| | 100F | ADD | AL,BL | 00 D8 | ; ADD two data |
| | 1011 | MOV | [DI],AL | 88 05 | ;Store result |
| | 1013 | INC | DI | 47 | ; Increment DI |
| | 1014 | INC | SI | 46 | ; Increment SI |
| | 1015 | DEC | CL | FE C9 | ;Decrement CL |
| | 1017 | JNZ | LOOP | 75 F2 | ; Loop continues until zero |
| | 1019 | INT | 3 | CC | ; Break point |

| Address | Input | Address | Input |
|---------|-------|---------|-------|
| 1200 | 01 | 1300 | 12 |
| 1201 | 02 | 1301 | 02 |
| 1202 | 03 | 1302 | 04 |
| 1203 | 04 | 1303 | 06 |
| 1204 | 05 | 1304 | 08 |
| 1205 | 06 | 1305 | 02 |
| 1206 | 07 | 1306 | 04 |
| 1207 | 08 | 1307 | 06 |
| 1208 | 09 | 1308 | 03 |

| Address | Output |
|---------|--------|
| 1300 | 13 |
| 1301 | 04 |
| 1302 | 07 |
| 1303 | 0A |
| 1304 | 0D |
| 1305 | 08 |
| 1306 | 0B |
| 1307 | 0E |
| 1308 | 0C |

PROGRAM for Matrix operation using MASM assembler

.MODEL SMALL

.DATA

TAB DB 3,4,5,6,0

DB 1,4,5,7,0

DB 1,8,9,0,0

DB 1,8,9,2,0

DB 1,1,1,1,0

DB 0,0,0,0,0

TOTROWS DB 0

TOTCOLS DB 0

ROWS DB 5

COLS DB 4

.CODE

MOV AX,@DATA

MOV DS,AX

; COUNTING TOTAL ROWS

LEA SI,TAB

L1: MOV CX,4

L2: MOV AH,BYTE PTR[SI]

ADD TOTROWS ,

AH INC SI

```
LOOP L2
MOV AH,TOTROWS
MOV [SI],AH
MOV TOTROWS,0
INC SI
SUB ROWS,1
CMP ROWS,0
JG L1
```

; COUNTING TOTAL COLS

```
LEA SI,TAB
MOV BX,00
L3: MOV CX,5
LEA SI,TAB
ADD SI,BX
L4: MOV AH,BYTE PTR[SI]
ADD TOTCOLS , AH
ADD SI,5
LOOP L4
MOV AH,TOTCOLS
MOV [SI],AH
MOV TOTCOLS,0
SUB COLS,1
CMP COLS,0
ADD BX,1
JG L3
MOV AX,4C00H
INT 21H
END
```

RESULT:

Thus the matrix operation and code conversion were executed and verified successfully.

VIVA QUESTIONS AND ANSWERS

1. Difference between JMP and JNC?

A:-JMP is Unconditional Branch.
JNC is Conditional Branch.

2.What are the 4 Segments in 8086?

A:-Code Segment Register {CS}
Data Segment Register {DS}
Extra Segment Register {ES}
Stack Segment Register {SS}

3. Distinguish between packed BCD and unpacked BCD

Packed BCD numbers are stored two digits to a byte in 4 bit groups referred as nibbles
Ex:86 in unpacked BCD there is only one digit per byte Ex: 08, 06

4. Describe CBW and CWD instructions

The CBW and CWDE mnemonics reference the same opcode. The CBW instruction is intended for use when the operand-size attribute is 16 and the CWDE instruction for when the operand-size attribute is 32. The CWDE instruction is different from the CWD (convert word to double) instruction. The CWD instruction uses the DX:AX register pair as a destination operand; whereas, the CWDE instruction uses the EAX register as a destination.

5. Describe about MUL, IMUL, DIV, IDIV instructions

MUL (multiply) instruction is used for unsigned multiplication. This instruction multiplies bytes or words.

IMUL (Integer multiply) instruction is used for signed multiplication. This instruction multiply bytes or words.

The DIV instruction is to divide unsigned data. We can divide a byte by byte, a word by byte, double word by word.

The IDIV instruction is to divide signed data. We can divide a byte by byte, a word by byte, double word by word and the operations are just like DIV instructions

6.Describe about LOOP instructions

The LOOP instruction is a combination of a decrement of CX and a conditional jump. In the 8086, LOOP decrements CX and if CX is not equal to zero, it jumps to the address indicated by the label. If CX becomes a 0, the next sequential instruction executes.

5. MOVE A DATA BLOCK WITHOUT OVERLAP

AIM:

To convert a given Move a data block without overlap using u086 MASM assembler and 8086 kit.

ALGORITHM:

1. Initialize the memory location to the data pointer.
2. Increment B register.
3. Increment accumulator by 1 and adjust it to decimal every time.
4. Compare the given decimal number with accumulator value.
5. When both matches, the equivalent hexadecimal value is in B register.
6. Store the resultant in memory location.

| Move data block without overlap using 8086 kit | | | |
|--|---------|----|--------------|
| 1000 | | | ORG 1000H |
| 1000 | B8 0000 | | MOV AX,0000H |
| 1003 | 8E D8 | | MOV DS,AX |
| 1005 | B9 0005 | | MOV CX,0005 |
| 1008 | BF 3000 | | MOV DI,3000H |
| 100B | BE 1200 | | MOV SI,1200H |
| 100E | 8B 04 | L1 | MOV AX,[SI] |
| 1010 | 89 05 | | MOV [DI],AX |
| 1012 | 46 | | INC SI |
| 1013 | 47 | | INC DI |
| 1014 | 49 | | DEC CX |
| 1015 | 8B C1 | | MOV AX,CX |
| 1017 | 75 F5 | | JNZ L1 |
| 1019 | B4 4C | | MOV AH,4CH |
| 101B | CD 21 | | INT 21H |
| | | | |

OBSERVATION:

INPUT:

1200 = 14H

1201 = 35H

1202 = 18H

1203 = 36H

1204 = 54H

OUTPUT:

1300 = 14H

1301 = 35H

1302 = 18H

1303 = 36H

1304 = 54H

PROGRAM

Move data block without overlap using 8086 MASM Assembler

DATA SEGMENT X DB 01H,02H,03H,04H,05H ;Initialize Data Segments Memory Locations

Y DB 05 DUP (0)

DATA ENDS

CODE SEGMENT ASSUME CS: CODE, DS: DATA

START:

MOV AX, DATA ; Initialize DS to point to start of the memory

MOV DS, AX ; set aside for storing of data

MOV CX, 05H ; Load counter

LEA SI, X+04 ; SI pointer pointed to top of the memory

LEA DI, X+04+03 ; 03 is displacement of over lapping, DI pointed to; the top of the destination block

CODE ENDS

END START

RESULT:

Thus the program for moving the data block without overlap was executed and verified using 8086 MASM assembler and 8086 kit.

VIVA QUESTIONS AND ANSWERS

1. Give examples of conditional branch instructions

In a loop if there are different jump instructions with a condition or counter called conditional loop and instructions in that loop are called unconditional branch instructions.

2. Give examples of unconditional branch instructions

In a loop if there are different jump instructions with no condition it is called unconditional loop and instructions in that loop are called unconditional branch instructions.

3. What are flag manipulation instructions ? Give examples

Flag manipulation instructions. STC, CLC, CMC. Set, clear, complement carry flag. STD, CLD. Set, clear direction flag

4. Explain about DAA instruction

decimal adjust addition result

DAA

The daa instruction is used to adjust the content of the AL register after that register is used to perform the addition of two packed BCDs.

5. Explain about CALL and RETURN instructions

CALL 16-bit memory address of a subroutine

It is a 3-byte instruction that transfers the program sequence to a subroutine

RETURN instruction in the subroutine. The return instruction is used either to return a function value or to terminate the execution of a function.

6. PASSWORD CHECKING, PRINT RAM SIZE AND SYSTEM DATE

AIM:

To write an 8086 MASM assembler program for performing password checking, Print RAM size and system date.

APPARATUS REQUIRED:

| SL.NO | ITEM | QUANTITY |
|-------|---------------------------------|----------|
| 1. | 8086 Microprocessor kit | 1 |
| 2. | Intel Desktop systems with MASM | 1 |
| 3. | RTC Interface board | 1 |

PROGRAM:

6 A) PASSWORD CHECKING

```
; PASSWORD IS MASM1234
DATA SEGMENT
PASSWORD DB 'MASM1234'
LEN EQU ($-PASSWORD)
MSG1 DB 10,13,'ENTER YOUR PASSWORD: $'
MSG2 DB 10,13,'WELCOME TO ELECTRONICS WORLD!!$'
MSG3 DB 10,13,'INCORRECT PASSWORD!$'
NEW DB 10,13,'$'
INST DB 10 DUP(0)
DATA ENDS
CODE SEGMENT
ASSUME CS: CODE, DS:
DATA START:
MOV AX,DATA
MOV DS,AX
LEA DX,MSG1
MOV AH,09H
INT 21H
MOV SI,00
UP1:

MOV AH,08H
INT 21H

CMP AL,0DH
```

6 B)DISPLAY MONTH/DAY/YEAR

.MODEL SMALL

.STACK 64

.DATA

Today

SAVEDAY DB ?

SAVEMON DB ?

TEN DB 10

ELEVEN DB 11

TWELVE DB 12

DAYSTAB DB ' SUNDAY, \$ ', ' MONDAY, \$ '

DB ' TUESDAY, \$ ', ' WEDNESDAY, \$ '

DB ' THURSDAY, \$ ', ' FRIDAY, \$ '

DB ' SATURDAY, \$ '

MONTAB DB ' JANUARY \$ ', ' FEBUARY \$ ', ' MARCH \$ '

DB ' APRIL \$ ', ' MAY \$ ', ' JUNE \$ '

DB ' JULY \$ ', ' AUGUST \$ ', ' SEPTEMBER \$ '

DB ' OCTOBER \$ ', ' NOVEMBER \$ ', ' DECEMBER \$ '

CODE

BEGIN PROC FAR

MOV AX,@DATA

MOV DS,AX

MOV ES,AX

MOV AX,0600H

CALL Q10SCR

CALL Q20CURS

MOV AH,2AH

INT 21H

MOV SAVEMON,DH

MOV SAVEDAY,DL

CALL B10DAYWK

CALL C10MONTH

CALL D10DAYMO

CALL E10INPT

CALL Q10SCR

```

MOV AX,4C00H
INT 21H
BEGIN ENDP
B10DAYWK PROC NEAR
MUL TWELVE
LEA DX,DAYSTAB
ADD DX,AX
MOV AH,09H
INT 21H
RET
B10DAYWK ENDP
C10MONTH PROC NEAR
MOV AL,SAVEMON
DEC AL
MUL ELEVEN
LEA DX,MONTAB
ADD DX,AX
MOV AH,09H
INT 21H
RET
C10MONTH ENDP
.386
D10DAYMO PROC NEAR
MOVZX AX,SAVEDAY
DIV TEN
OR AX,3030H
MOV BX,AX
MOV AH,02H
MOV DL,BL
INT 21H
MOV AH,02H
MOV DL,BH
INT 21H
RET

```

```
D10DAYMO          ENDP

E10INPT           PROC   NEAR
                  MOV    AH,10H
                  INT    16H
                  RET
E10INPT           ENDP

Q10SCR            PROC   NEAR
                  MOV    AX,0600H
                  MOV    BH,17H
                  MOV    CX,0000
                  MOV    DX,184FH
                  INT    10H
                  RET
Q10SCR            ENDP
Q20CURS           PROC   NEAR
                  MOV    AH,02H
                  MOV    BH,00
                  MOV    DH,10
                  MOV    DL,24
                  INT    10H
                  RET
Q20CURS           ENDP
                  END    BEGIN
```

6 C) RAM SIZE

```
ORG 0000H
CLR
CLR
CPL A
ADD A, #01H
MOV A,R3
AGAIN: SJMP AGAIN
*****
```

Observation:

OUTPUT

“RAM SIZE IS 16 KB” is displayed in the LCD.

RESULT:

Thus the output for the Password checking, Print RAM size and system date was executed and verified using MASM assembler successfully

VIVA QUESTIONS AND ANSWERS

1. How do you read and write characters on to screen using interrupts?

An interrupt is a condition that causes the microprocessor to temporarily work on a different task, and then later return to its previous task. Interrupts can be internal or external.

2. What is the significance of LEA instruction?

LEA(Load Effective Address) is used for initializing a register with an offset address. A common use for LEA is to initialize an offset in BX, DI or SI for indexing an address in memory.

An equivalent operation to LEA is MOV with the OFFSET operator, which generates slightly shorter machine code.

3. What is an assembler directive?

An assembler directive is a direct command to microprocessor to perform certain operations.

4. How the assembler process is carried out in 8086?

A microprocessor executes a collection of machine instructions that tell the processor what to do is known as assembly process.

5. How a procedure is represented in assembler directive?

Procedures are a group of instructions stored as a separate program in memory and it is called from the main program whenever required. The type of procedure depends on where the procedures are stored in memory. If it is in the same code segment as that of the main program then it is a near procedure otherwise it is a far procedure.

7. COUNTERS AND TIME DELAY

AIM:

To write an assembly language program for up counter using 8086 kit and 8086 MASM assembler.

APPARATUS REQUIRED:

| SL.NO | ITEM | SPECIFICATION | QUANTITY |
|-------|---------------------|------------------|----------|
| 1. | Microprocessor kit | 8086 kit | 1 |
| 2. | Power Supply | +5 V, dc,+12V dc | 1 |
| 3. | RTC Interface board | – | – |

PROCEDURE:

1. Enter the program into the kit
2. Execute the program
3. The counter value displayed in the LCD, he value starts from 00H TO 99H

PROGRAM

UP COUNTER using 8086 kit

```
1000      EB 2F 10   START:   CALL CONVERT
1003      E8 00 1D           CALL DISPLAY
1006      B9 00 00   DELAY:   MOV CX,0000H
1009      41           L1:     INC CX
100A      81 F9 FF FF           CMP CX,0FFFFH
100E      75 F9           JNZ L1
1010      BE 00 15           MOV SI,1500H
1013      8A 04           MOV AL,[SI]
1015      FE C0           INC AL
1017      88 04           MOV [SI],AL
1019      3C 64           CMP AL,064H
101B      75 E3           JNZ START
101D      B0 00           MOV AL,00H
101F      88 04           MOV [SI],AL
1021      EB DD           JMP START
1023      B4 06   DISPLAY:  MOV AH,06H
1025      BA 00 16           MOV DX,1600H
1028      B5 01           MOV CH,01H
102A      B1,00           MOV CL,00H
102C      CD 05           INT 5
102E      C3           RET
102F      BE 00 15   CONVERT:  MOV [SI],1500H
1032      BB 02 16           MOV BX,1602H
1035      B0 24           MOV AL,24H
1037      88 07           MOV [BX],AL
1039      8A 04           MOV AL,[SI]
103B      B4 00           MOV AH,00H
103D      B6 0A           MOV DH,0AH
103F      F6 F6           DIV DH
1041      80 C4 30           ADD AH,30H
1044      4B           DEC BX
1045      88 27           MOV[BX],AH
1047      4B           DEC BX
1048      04 30           ADD AL,30H
104A      88 07           MOV [BX],AL
104C      4B           DEC BX
104D      C3           RET
104E      E4 02   GETC:    IN AL,02H
1050      24 FF           AND AL,0FFH
1052      3C F0           CMP AL,0F0H
1054      75 F8           JNE GETC
1055      F4           HLT
```

UP COUNTER using 8086 MASM assembler

```
MODEL SMALL
STACK 100H
DATA
PROMPT DB 'The counting from 0 to 9 is : $'
CODE
MAIN PROC
MOV AX, @DATA           ; initialize DS
MOV DS, AX
LEA DX, PROMPT         ; load and print PROMPT
MOV AH, 9
INT 21H
MOV CX, 10              ; initialize CX
MOV AH, 2               ; set output function
MOV DL, 48              ; set DL with 0
@LOOP:                 ; loop label
INT 21H                 ; print character
INC DL                  ; increment DL to next ASCII character
DEC CX                  ; decrement CX
JNZ @LOOP               ; jump to label @LOOP if CX is 0
MOV AH, 4CH             ; return control to DOS
INT 21H
MAIN ENDP
END MAIN
```

RESULT:

Thus the program for up counter using 8086 MASM assembler was executed and verified successfully

VIVA QUESTIONS AND ANSWERS

1. What is a RAM?

RAM is a random access memory which is used to store data temporarily.

2. What are the types of RAM?

Static RAM, Dynamic RAM

3. How many 32kB RAMs can be interfaced with 8086?

4 32kB RAMs can be interfaced with 8086

4. What is the necessity of RAM in processor?

RAM is necessary to hold the data temporarily when a processor is executing any program.

5. Differentiate EPROM and EEPROM.

EPROM and EEPROM both are erasable and can be reprogrammed, but the basic difference between them is that **EPROM** is erased using **Ultra violet rays** whereas, **EEPROM** can be erased using **electric signals**. Let us discuss the differences between EPROM and EEPROM with the help of comparison chart shown below.

8. TRAFFIC LIGHT CONTROL

AIM:-

To write an assembly program for Traffic Light Control using 8086 LCD Microprocessor Kit.

PROGRAM:

```

CNTRL    EQU    26H
PORT A   EQU    20H
PORT B   EQU    22H
PORT C   EQU    24H
    
```

| Label | Address | Mnemonics | | Hex code | Comments |
|--------|---------|--------------|--------------|-------------|----------|
| | | Opcode | Operand | | |
| START | 1000 | MOV | AL,80H | C6 C0 80 | |
| | 1003 | OUT | (CNTRL)26,AL | E6 26 | |
| REPEAT | 1005 | MOV | BX,LOOK UP | C7 C3 73 10 | |
| | 1009 | MOV | SI,LABEL | C7 C6 7F 10 | |
| | 100D | CALL | OUT | E8 33 00 | |
| | 1010 | MOV | AL,[SI] | 8A 04 | |
| | 1012 | OUT | (PORTA)20,AL | E6 20 | |
| | 1014 | CALL | DELAY 1 | E8 4D 00 | |
| | 1017 | INC | SI | 46 | |
| | 1018 | INC | BX | 43 | |
| | 1019 | CALL | OUT | E8 27 00 | |
| | 101C | MOV | AL,[SI] | 8A 04 | |
| | 101E | OUT | (PORTB)22,AL | E6 22 | |
| | 1020 | CALL | DELAY 1 | E8 41 00 | |
| | 1023 | INC | SI | 46 | |
| | 1024 | INC | BX | 43 | |
| | 1025 | CALL | OUT | E8 1B 00 | |
| | 1028 | MOV | AL,[SI] | 8A 04 | |
| 102A | OUT | (PORTC)24,AL | E6 24 | | |
| 102C | CALL | DELAY 1 | E8 35 00 | | |
| 102F | INC | SI | 46 | | |
| 1030 | INC | BX | 43 | | |

| | | | | |
|----------|------|------|---------------|-------------|
| | 1031 | CALL | OUT | E8 0F 00 |
| | 1034 | MOV | AL,[SI] | 8A 04 |
| | 1036 | OUT | (PORTC)24,AL | E6 24 |
| | 1038 | INC | SI | 46 |
| | 1039 | MOV | AL,[SI] | 8A 04 |
| | 103B | OUT | (PORTA)20,,AL | E6 26 |
| OUT: | 103D | CALL | DELAY 1 | E8 24 00 |
| | 1040 | JMP | REPEAT | E9 C2 FF |
| | 1043 | MOV | AL,[BX] | 8A 07 |
| | 1045 | OUT | (PORTC)24,AL | E6 24 |
| | 1047 | INC | BX | 43 |
| | 1048 | MOV | AL,[BX] | 8A 07 |
| | 104A | OUT | (PORTB)22,AL | E6 22 |
| | 104C | INC | BX | 43 |
| | 104D | MOV | AL,[BX] | 8A 07 |
| | 104F | OUT | (PORTA)20,AL | E6 20 |
| DELAY: | 1051 | CALL | DELAY | E8 01 00 |
| A: | 1054 | RET | | C3 |
| A1: | 1055 | MOV | DI,00040H | C7 C7 40 00 |
| | 1059 | MOV | DX,0FFFFH | C7 C2 FF FF |
| | 105D | DEC | DX | 4A |
| | 105E | JNZ | A1 | 75 FD |
| | 1060 | DEC | DI | 4F |
| DELAY1: | 1061 | JNZ | A | 75 F6 |
| B: | 1063 | RET | | C3 |
| B1: | 1064 | MOV | DI,00015H | C7 C7 15 00 |
| | 1068 | MOV | DX,0FFFFH | C7 C2 FF FF |
| | 106C | DEC | DX | 4A |
| | 106D | JNZ | B1 | 75 FD |
| | 106F | DEC | DI | 4F |
| LOOK UP: | 1070 | JNZ | B | 75 F6 |
| | 1072 | RET | | C3 |

| | | | | | |
|--------|------|----|-----------------|--|--|
| LABEL: | 1073 | DB | 12H,27H,44H,10H | | |
| | 1077 | | 2BH,92H,10H,9DH | | |
| | 107B | | 84H,48H,2EH,84H | | |
| | 107F | DB | 48H,6BH,20H,49H | | |
| | 1083 | | 04 | | |

VIVA QUESTIONS AND ANSWERS

1. Give the sequence of operation in traffic light controller.

The typical sequence is as follows:

Green (safe to proceed)

Amber (slow down, red light soon)

Red (stop)

Red / amber (stay stopped but just letting you know the light turns green soon)

2. What is the name of the peripheral device used to interface traffic light controller with microprocessor?

8255 PPI(Programmable peripheral Interface)

3. What is 8255?

It is PPI- Programmable Peripheral Interface. it is used to connect I/O devices to microprocessor and supports parallel communication.

4. How many input and output ports are in PPI?

The port is a buffered I/O, which is used to hold the data transmitted from the processor to I/O device or vice-versa

5. What is BSR mode?

Bit set or reset mode, If BSR=1,bit is set,,if BSR=0,it is reset.

RESULT:

Thus the assembly language program for Traffic Light Control was executed and verified using 8086 Microprocessor kit.

FLOW CHART:

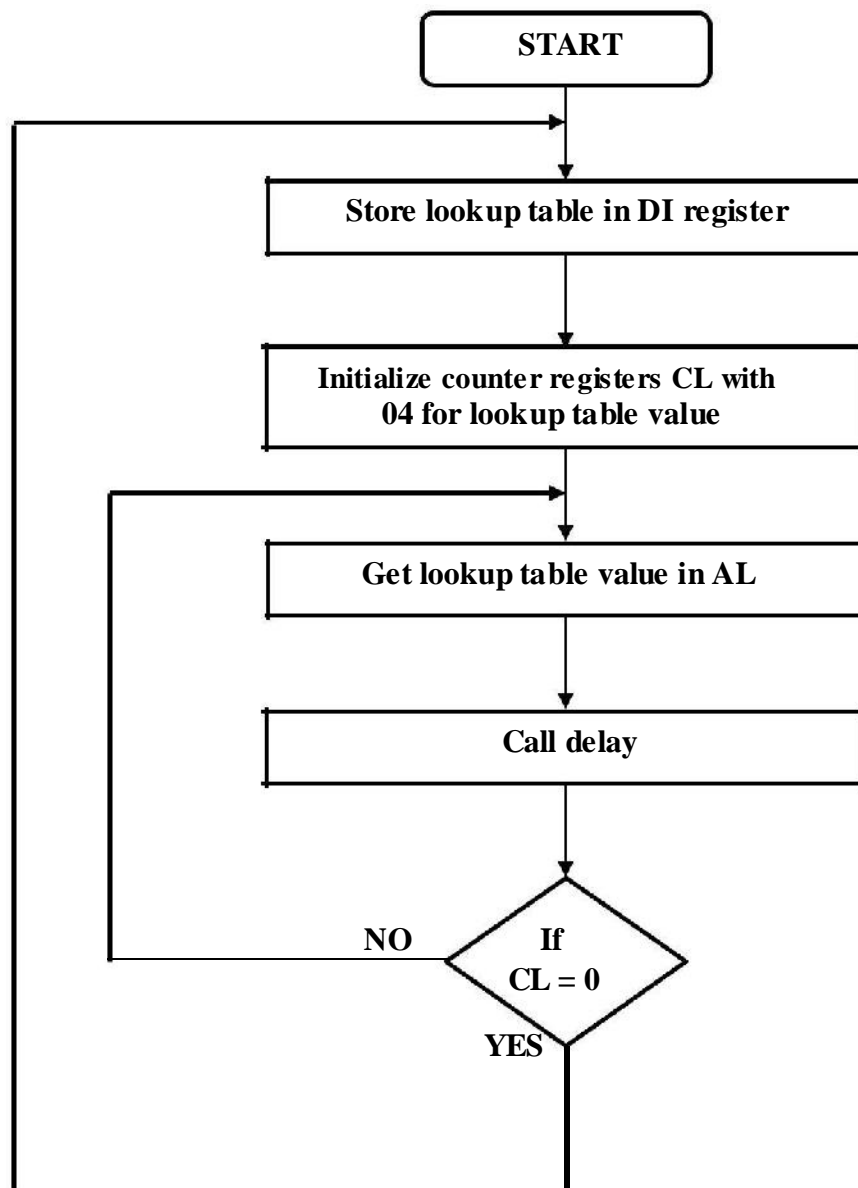

9. STEPPER MOTOR CONTROL

AIM:-

To write an assembly language program to control the speed of stepper motor in both directions using 8086 Microprocessor kit.

APPARATUS REQUIRED:

- i. Microprocessor kit
- ii. Stepper Motor Interface Card
- iii. Stepper motor

ALGORITHM:-

- a. Start the program
- b. Store lookup table value in DI register
- c. Initialize counter register CL with 04H for lookup table value.
- d. Get lookup table value in CL.
- e. Call delay
- f. If CL = 0, go to step1 otherwise get next lookup table value.

Lookup table:-

(Anti clock wise direction)

1200 : 09
1201 : 05
1202 : 06
1203 : 0A

(Clockwise direction)

1200 : 0A
1201 : 06
1202 : 05
1203 : 09

PROGRAM:

| Label | Address | Mnemonics | | Hex code | Comments |
|--------|---------|-----------|----------|-------------|---------------------------|
| | | Opcode | Operand | | |
| START | 1000 | MOV | DI,1200 | C7,C7,00,12 | ; Initialize lookup table |
| | 1004 | MOV | CL,04 | C6,C1,04 | ;Initialize count value |
| REPEAT | 1007 | MOV | AL,[DI] | 8A 05 | Get lookup table value |
| | 1009 | OUT | C0,AL | E6 C0 | ;Sent it to output port |
| | 100B | MOV | DX,1010H | C7 C2 10 10 | ;Delay program |
| DELAY | 100F | DEC | DX | 4A | |
| | 1010 | JNZ | DELAY | 75 FD | |
| | 1012 | INC | DI | 47 | ;Increment [DI] |
| | 1013 | LOOP | REPEAT | E2 F2 | ;if CX ≠ 0, go to Repeat |
| | 1015 | JMP | START | E9 E8 FF | ;Repeat to start |

VIVA QUESTIONS AND ANSWERS**1. What are the applications of stepper motor**

Used in tape drives, floppy disc drives printers and electric watches. The **stepper motor** also use in X-Y plotter and robotics

2. Discuss the salient features of stepper motor

The rotation angle of the **motor** is proportional to the input pulse.

The **motor** has full torque at standstill. Precise positioning and repeatability of movement since good **stepper motors** have an accuracy of 3– 5% of a step and this error is non cumulative from one step to the next.

3. What are the schemes used in stepper motor

A microcontroller or stepper motor controller can be used to activate the drive . Various drive techniques have been developed to better approximate a sinusoidal drive waveform: these are half stepping and micro stepping.

4. Write the calculation for step size.

Let N_r be the number of rotor teeth and m be the number of stacks or phases.Hence, Tooth pitch is represented by the

$$T_p = \frac{360^\circ}{N_r} \dots \dots \dots (1)$$

Therefore,

$$\text{Step angle} = \frac{360^\circ}{m N_r} \dots \dots \dots (2)$$

5. How can the speed of stepper motor can be controlled?

To control the speed of a stepper motor, you control the time between steps. And as long as there is enough excess torque to keep up, you can control the position, speed, and acceleration.

RESULT:

Thus the assembly language program for speed control of stepper motor was executed and verified using 8086 Microprocessor kit.

| | | | | | |
|------------|------|---------|----------|-------------|--|
| | 104E | IN | AL, D0H | E4 D0 | |
| | 1050 | AND | AL,0FH | 80 E0 0F | |
| OUT_CHECK: | 1053 | INC | SI | 46 | |
| | 1054 | MOV | [SI],AL | 88 04 | |
| | 1056 | IN | AL, C0H | E4 C0 | |
| | 1058 | AND | AL,0FH | 80 E0 0F | |
| | 105B | INC | SI | 46 | |
| | 105C | MOV | [SI],AL | 88 04 | |
| | 105E | MOV | SI,1320H | C7 C6 20 13 | |
| | 1062 | MOV | AL,[SI] | 8A 04 | |
| | 1064 | OUT | E0,AL | E6 E0 | |
| | 1066 | INC | SI | 46 | |
| | 1067 | MOV | AL,[SI] | 8A 04 | |
| | 1069 | OUT | F0,AL | E6 F0 | |
| | 106B | INC | SI | 46 | |
| | 106C | MOV | AL,[SI] | 8A 04 | |
| | 106E | OUT | E2,AL | E6 E2 | |
| | 1070 | INC | SI | 46 | |
| | 1071 | MOV | AL,[SI] | 8A 04 | |
| | 1073 | OUT | F2,AL | E6 F2 | |
| | 1075 | INC | SI | 46 | |
| | 1076 | MOV | AL,[SI] | 8A 04 | |
| 1078 | OUT | E4,AL | E6 E4 | | |
| 107A | INC | SI | 46 | | |
| 107B | MOV | AL,[SI] | 8A 04 | | |
| 107D | OUT | F4,AL | E6 F4 | | |
| 107F | JMP | L1 | E9 A9 FF | | |
| | 1082 | ENDS | | | |

Observation:

Input

| | |
|------|----|
| 1200 | 00 |
| 1201 | 00 |
| 1202 | 00 |
| 1203 | 00 |
| 1204 | 00 |

Output:

Time is displayed in the RTC board as

| | ! Hour | ! Minutes | ! seconds | ! |
|---|--------|-----------|-----------|-----|
| X | 0 | 0 | 0 | 5 9 |
| X | 0 | 0 | 1 | 0 0 |

RESULT:

Thus the digital clock program has been written and executed using 8086 microprocessor kit and the output of digital clock was displayed as [hours: minutes: seconds] successfully.

VIVA QUESTIONS AND ANSWERS

1. What type of RTC kit is used?

DS1307

2. What is the format of time being displayed?

HH:MM:SS

3. What are the different functionalities of RTC kit?

The purpose of an **RTC** or a **real time clock** is to provide precise time and date which can be used for various applications

4. Whether 7 segment display used here is common anode or common cathode type.

common anode type 7 segment display

5. What are the addresses of hour, minute and seconds register?

Bit 6 of the hours register is defined as the 12- or 24-hour mode select bit. When high, the 12-hour mode is selected. In the 12-hour mode, bit 5 is the AM/PM bit with logic high being PM. In the 24-hour mode, bit 5 is the second 10 hour bit (20- 23 hours).

11. KEY BOARD AND DISPLAY

AIM:-

To write an assembly language program to interfacing of 8279 with 8086.

APPARATUS REQUIRED:-

- 8086 Microprocessor kit
- 8279 interface board

ALGORITHM:-

(a) Rolling Display

Step1: Start the process

Step2: Initialize lookup table pointer, counter of keyboard display mode of 8279.

Step3: Initialize the prescalar counter and clear the display.

Step4: Get the seven segment display & carried it, in display RAM.

Step5: Increment the look up table pointer.

Step6: Decrement the counter until it becomes zero.

Step7: Stop the process.

(b) Accept a key and display it using 8279

Step1: Start the process

Step2: Set the data to set mode & display

Step3: Initialize the counter and clear the display RAM.

Step4: Write the display RAM command.

Step5: Clear the display RAM.

Step6: Decrement the counter value until it becomes zero.

Step7: Get the key data to be displayed.

Step8: Set the memory to need the FIFO RAM.

Step9: Get the corresponding code from look up table.

Step10: Store it is necessary.

Step11: Stop the process.

FLOW CHART:

(a) Rolling Display

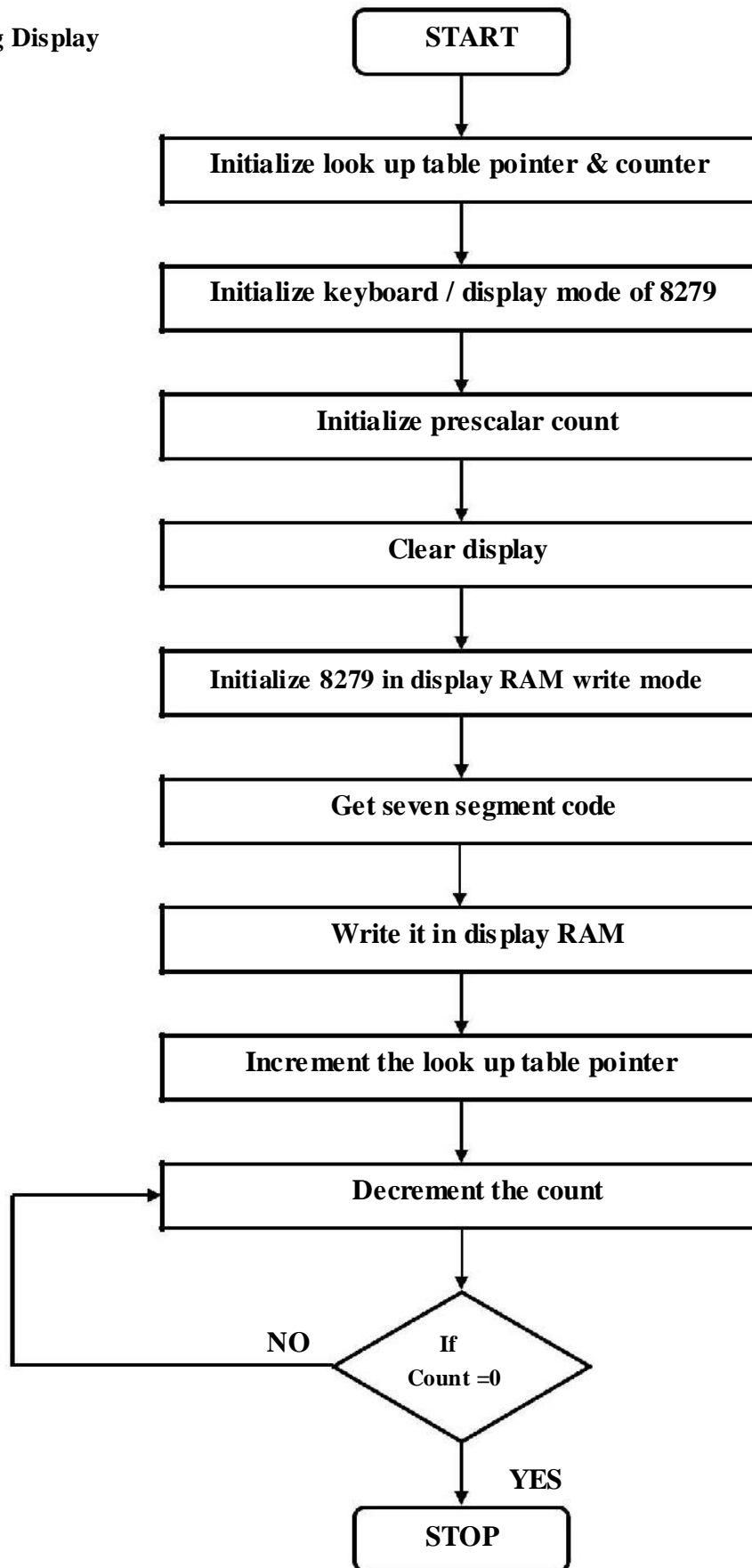

PROGRAM:-**To Display 'A'**

| Label | Address | Mnemonics | | Hex code | Comments |
|-------|---------|-----------|---------|-------------|--|
| | | Opc ode | Operand | | |
| START | 1000 | MOV | AL,00 | C6 C0 00 | ; Display & keyboard mode set ; Clear Display ; Write display RAM ; Get character ; Blank unused 7segment LED's |
| | 1003 | OUT | C2,AL | E6 C2 | |
| | 1005 | MOV | AL,0CC | C6 C0 CC | |
| | 1008 | OUT | C2,AL | E6 C2 | |
| | 100A | MOV | AL,90 | C6 C0 90 | |
| | 100D | OUT | C2,AL | E6 C2 | |
| | 100F | MOV | AL,88 | C6 C0 88 | |
| | 1012 | OUT | C0,AL | E6 C0 | |
| | 1014 | MOV | AL,0FF | C6, C0 FF | |
| | 1017 | MOV | CX,0005 | C7 C1 05 00 | |
| NEXT | 101B | OUT | C0,AL | E6 C0 | |
| | 101D | LOOP | NEXT | E2 FC | |
| | 101F | HLT | | F4 | ; Stop the program |

FLOW CHART:-

(b) Accept a key and display

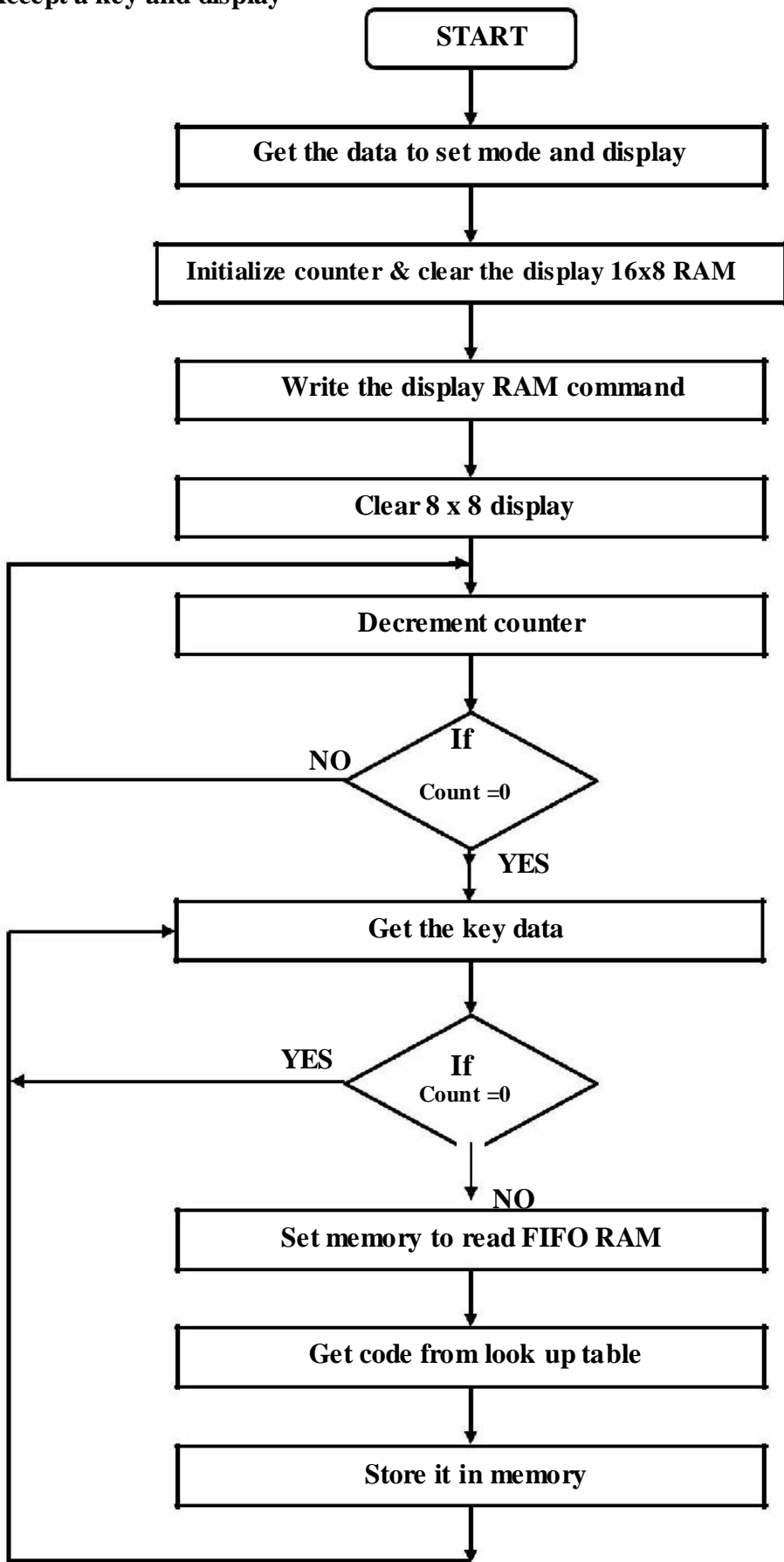

PROGRAM:- To Rolling Display (Display message is ' HELP US')

| Label | Address | Mnemonics | | Hex code | Comments | |
|--------|---------|-----------|----------|-------------|--|-------|
| | | Opcode | Operand | | | |
| START | 1000 | MOV | SI,1200 | C7 C6 00 12 | ; load lookup table ;Display / keyboard mode set ; Clear Display ; Write display RAM ; Get to be displayed character ;Call display program ;Repeat | |
| | 1004 | MOV | CX,000F | C7 C1 0F 00 | | |
| | 1008 | MOV | AL,10 | C6C010 | | |
| | 100B | OUT | C2,AL | E6 C2 | | |
| | 100D | MOV | AL,0CC | C6 C0 CC | | |
| | 1010 | OUT | C2,AL | E6 C2 | | |
| | 1012 | MOV | AL,90 | C6 C0 90 | | |
| | 1015 | OUT | C2,AL | E6 C2 | | |
| | NEXT: | 1017 | MOV | AL,[SI] | | 8A 04 |
| | 1019 | OUT | C0,AL | E6 C0 | | |
| | 101B | CALL | DELAY | E8 E2 04 | | |
| | 101E | INC | SI | 46 | | |
| | 101F | LOOP | NEXT | E2 F6 | | |
| | 1021 | JMP | START | E9 DC FF | | |
| DELAY | 1500 | MOV | DX,0A0FF | C7 C2 FF A0 | ;Delay program | |
| LOOP1: | 1504 | DEC | DX | 4A | | |
| | 1505 | JNZ | LOOP1 | 75 FD | | |
| | 1507 | RET | | C3 | | |

| LOOK – UP – TABLE (“HELP US”) | | | | | |
|-------------------------------|------|------|------|------|------|
| 1200 | 1201 | 1202 | 1203 | 1204 | 1205 |
| FF | FF | FF | FF | FF | FF |
| 1206 | 1207 | 1208 | 1209 | 120A | 120B |
| FF | FF | 98 | 68 | 7C | C8 |
| 120C | 120D | 120E | 120F | | |
| FF | 1C | 29 | FF | | |

RESULT:-

Thus the assembly language program for interfacing 8279 keyboard and display controller with 8086 microprocessor trainer kit was executed and successfully verified.

VIVA QUESTIONS AND ANSWERS

1. Give some examples of input devices to microprocessor-based system.

The input devices used in the microprocessor-based system are Keyboards, DIP switches, ADC, Floppy disc, etc.

2. What are the tasks involved in keyboard interface?

The tasks involved in keyboard interfacing are sensing a key actuation, debouncing the key and generating key codes (Decoding the key). These tasks are performed in software if the keyboard is interfaced through ports and they are performed by hardware if the keyboard is interfaced through 8279.

3. How a keyboard matrix is formed in keyboard interface using 8279?

The return lines, RLo to RL7 of 8279 are used to form the columns of keyboard matrix. In decoded scan mode, the scan lines SLo to SL3 of 8279 are used to form the rows of keyboard matrix. In encoded scan mode, the output lines of external decoder are used as rows of keyboard matrix.

4. What is scanning in keyboard and what is scan time?

The process of sending a zero to each row of a keyboard matrix and reading the columns for key actuation is called scanning. The scan time is the time taken by the processor to scan all the rows one by one starting from the first row and coming back to the first row again.

5. What is scanning in display and what is the scan time?

In display devices, the process of sending display codes to 7-segment LEDs to display the LEDs one by one is called scanning (or multiplexed display). The scan time is the time taken to display all the 7-segment LEDs one by one, starting from the first LED and coming back to the first LED again.

4G /5G

COMMUNICATION NETWORKS

Edited by :

T.DIVYAMANOHARI



978-93-6255-513-7

4G/5G COMMUNICATION NETWORKS Copyright @ 2023 by *Mrs. T.DIVYAMANOHARI*

All rights reserved. No part of this book may be reproduced or transmitted in any form or by any means without written permission from the author.

ISBN: 978-93-6255-513-7

Publisher: PUBLICATIONS

TABLE OF CONTENTS

| CHAPTER | CONTENT | PAGE |
|----------------|---|-------------|
| | INTRODUCTION | 5 |
| 1 | FUNDAMENTALS OF 4G NETWORKS R.SARASWATHI | 13 |
| 2 | 5G NETWORK ARCHITECTURE Dr. N. PARVATHAM | 28 |
| 3 | RADIO ACCESS TECHNOLOGIES A.AMUDHA | 49 |
| 4 | PERFORMANCE METRICS AND QUALITY OF SERVICE (QOS) A.AARTHI | 64 |
| 5 | APPLICATIONS OF 4G AND 5G Dr. S. DEVI | 85 |
| | REFERENCES | 100 |

CHAPTER 1 FUNDAMENTALS OF 4G NETWORKS

R.SARASWATHI

*Assistant Professor, Department of ECE
Ponnaiyah Ramajayam Institute of Science and Technology, Tamil Nadu, India.*

Fundamentals of 4G Networks

4G networks, also known as fourth-generation mobile communication networks, represent a significant leap from previous generations (1G, 2G, 3G) by providing faster data transfer speeds, better voice quality, and a broader range of services, especially for mobile internet.

1. Key Features of 4G:

High Data Rates: 4G provides peak download speeds of up to 1 Gbps (stationary) and 100 Mbps (while moving).

Low Latency: Latency in 4G networks can be as low as 50 milliseconds, making real-time applications like video conferencing smoother.

2. Core Technologies Used in 4G:

LTE (Long Term Evolution): LTE is the main technology behind 4G, designed to provide faster and more efficient communication. It's based on an all-IP (Internet Protocol) system for data transfer.

OFDM (Orthogonal Frequency Division Multiplexing): OFDM divides the frequency bands into multiple sub-bands to ensure efficient data transmission and reduce interference.

MIMO (Multiple Input Multiple Output): MIMO technology uses multiple antennas at the transmitter and receiver ends to increase the data throughput and reliability.

3. Architecture of 4G Networks:

User Equipment (UE): Devices like smartphones, tablets, and dongles that connect to the 4G network.

Evolved Packet Core (EPC): The core network for 4G that handles all data and internet services. It includes:

MME (Mobility Management Entity): Manages user mobility and session setup.

SGW (Serving Gateway): Routes and forwards data packets between the mobile device and the internet.

CHAPTER 2 5G NETWORK ARCHITECTURE

Dr. N. PARVATHAM

Associate Professor, Department of ECE

Ponnaiyah Ramajayam Institute of Science and Technology, Tamil Nadu, India.

5G Network Architecture

The 5G network architecture is designed to handle the increased demand for high-speed data, low latency, and massive connectivity for devices like smartphones, IoT devices, autonomous vehicles, and smart infrastructure. It represents a significant advancement over 4G, providing faster speeds, higher capacity, and more reliable communication. Here's an overview of 5G architecture:

1. Key Components of 5G Network Architecture

The 5G architecture consists of several key components that work together to enable faster communication, lower latency, and support for more devices.

1.1 User Equipment (UE)

User Devices: These include smartphones, IoT devices, sensors, wearables, and other devices that connect to the 5G network.

5G Modems: These are embedded in user devices and are capable of handling the high-speed data rates and low-latency requirements of 5G.

1.2 Radio Access Network (RAN)

The Radio Access Network in 5G includes all the components that connect the user devices to the core network.

gNodeB (gNB): This is the 5G equivalent of the eNodeB in 4G. It provides the radio interface for user devices and is responsible for managing the communication between the user devices and the core network.

Massive MIMO (Multiple Input Multiple Output): MIMO technology in 5G allows for multiple antennas on both the transmitter and receiver sides, enabling multiple data streams to be transmitted simultaneously, increasing capacity and speed.

Beamforming: This technology focuses the radio signal in a specific direction to improve the quality of the connection and reduce interference.

1.3 5G Core Network (5GC)

- **Access and Mobility Management Function (AMF):** Handles user registration, mobility management, and session establishment.
- **Session Management Function (SMF):** Manages user sessions, including IP address allocation, policy enforcement, and QoS (Quality of Service).
- **User Plane Function (UPF):** Responsible for routing and forwarding user data packets between the RAN and external data networks (like the internet).

CHAPTER 3 RADIO ACCESS TECHNOLOGIES

A.AMUDHA

Assistant Professor, Department of ECE

Ponnaiyah Ramajayam Institute of Science and Technology, Tamil Nadu, India.

1G (First Generation) – Analog Communication

Technology: Analog Cellular Systems

Example: AMPS (Advanced Mobile Phone System)

Data Rate: Voice-only, no data transmission.

Description: 1G represents the earliest form of mobile communication. These networks used analog technology for voice communication, with no support for data transmission. Due to limitations such as poor security, low voice quality, and inefficient use of spectrum, 1G networks were quickly phased out.

2. 2G (Second Generation) – Digital Communication

Technology: Digital Cellular Systems

Examples: GSM (Global System for Mobile Communications): The most widely used 2G standard globally, GSM introduced digital transmission for voice, SMS, and limited data services.

CDMA (Code Division Multiple Access): An alternative to GSM, CDMA assigns unique codes to multiple users and allows them to share the same frequency band.

Data Rate: Up to 64 kbps (with EDGE)

Description: 2G networks introduced digital encoding, improving voice quality and offering the first mobile data services, such as SMS and MMS. Technologies like GPRS (General Packet Radio Service) and EDGE (Enhanced Data rates for GSM Evolution) were introduced later to provide modest data transmission speeds.

3G (Third Generation) – Mobile Data

- Technology: Packet-Switched Networks
- Examples:
 - UMTS (Universal Mobile Telecommunications System): Based on W-CDMA (Wide-band CDMA) technology, UMTS provided significant improvements in data speed and capacity.
 - HSPA (High-Speed Packet Access): An enhancement of UMTS, HSPA provided higher data rates and better capacity for data services.
 - CDMA2000: Another 3G technology based on CDMA, widely used in countries like the U.S. and Japan.

CHAPTER 4 PERFORMANCE METRICS AND QUALITY OF SERVICE (QOS)

A.AARTHI

Assistant Professor, Department of ECE

Ponnaiyah Ramajayam Institute of Science and Technology, Tamil Nadu, India.

Performance Metrics and Quality of Service (QoS) in Networks

In telecommunications, Performance Metrics and Quality of Service (QoS) are essential for measuring and ensuring that network services meet users' expectations. These concepts are particularly important for mobile networks like 4G and 5G, where a variety of services (voice, video, data) and applications (smartphones, IoT, real-time communications) compete for bandwidth and resources.

1. Performance Metrics in Networks

Performance metrics help evaluate how well a network performs in terms of efficiency, speed, reliability, and user experience. Key performance metrics include:

1.1 Throughput

Definition: Throughput refers to the actual amount of data successfully transmitted over the network in a given amount of time, typically measured in bits per second (bps).

Importance: It measures the effectiveness of the network in delivering data to users, which directly affects user experience in tasks like video streaming or file downloads.

Factors Affecting Throughput:

Network congestion

Number of users connected

Distance from the base station

Device capabilities

1.2 Latency

Definition: Latency is the time it takes for a data packet to travel from the source to the destination, measured in milliseconds (ms). It is also known as delay.

Importance: Low latency is critical for real-time applications such as video conferencing, online gaming, and autonomous driving.

Types of Latency:

Propagation delay: Time taken for signals to travel through the network medium.

Processing delay: Time required by network devices (e.g., routers, switches) to process data packets.

CHAPTER 5 APPLICATIONS OF 4G AND 5G

Dr. S. DEVI

Associate Professor, Department of ECE

Ponnaiyah Ramajayam Institute of Science and Technology, Tamil Nadu, India

5G is designed to support not only higher data speeds but also massive device connectivity, ultra-low latency, and enhanced reliability. This allows for an expanded range of applications, particularly in industries that require real-time communication and automation.

1. Enhanced Mobile Broadband (eMBB)

Description: 5G enables ultra-fast download and upload speeds (up to 20 Gbps), allowing consumers to stream 4K/8K video, engage in AR/VR experiences, and download large files in seconds.

Example: Streaming 8K videos or downloading full-length movies in seconds becomes possible with 5G.

2. Augmented Reality (AR) and Virtual Reality (VR)

Description: With 5G's low latency (as low as 1 millisecond), AR and VR applications can operate in real time. This enables immersive gaming, virtual meetings, and interactive shopping experiences.

3. Autonomous Vehicles

Description: 5G provides the necessary ultra-low latency and high-reliability communications required for self-driving cars. Cars can communicate with each other (vehicle-to-vehicle or V2V), infrastructure (V2I), and pedestrians (V2P) to ensure road safety and efficiency.

Example: Companies like Tesla and Waymo are working on autonomous vehicles, which will rely on 5G networks for real-time decision-making and hazard avoidance.

4. IoT and Smart Cities

Description: 5G supports Massive Machine-Type Communication (mMTC), which allows billions of IoT devices to connect and operate efficiently. This is essential for smart city infrastructure, including smart lighting, traffic management, and environmental monitoring.

Example: Smart cities with intelligent transportation systems, waste management, and energy grids can function seamlessly using 5G networks.

SIGNALS AND SYSTEMS

Edited by

DR.C.RAJINIKANTH



978-93-6255-280-8

DIGITAL ELECTRONICS

COPYRIGHT @ 2023 BY S. SARASWATHI

ALL RIGHTS RESERVED. NO PART OF THIS BOOK MAY BE REPRODUCED OR TRANSMITTED IN ANY FORM OR BY ANY MEANS WITHOUT WRITTEN PERMISSION FROM THE AUTHOR.

ISBN: 9789362555496

PUBLISHER: Ponnaiyah Ramajayam Institute of Science and Technology (PRIST)

TABLE OF CONTENTS

| | |
|--|------------|
| INTRODUCTION..... | 3 |
| CHAPTER 1 DIGITAL FUNDAMENTALS..... | 5 |
| T. DIVYA MANOHARI | |
| CHAPTER 2 COMBINATIONAL CIRCUIT DESIGN..... | 20 |
| Dr. SMITHA ELSA PETER | |
| CHAPTER 3 SYNCHRONOUS SEQUENTIAL CIRCUITS..... | 34 |
| R. SAVITHA | |
| CHAPTER 4 ASYNCHRONOUS SEQUENTIAL CIRCUITS..... | 49 |
| Dr. S. DEVI | |
| CHAPTER 5 MEMORY DEVICES..... | 68 |
| S. MAHESHWARAN | |
| CHAPTER 6 DIGITAL INTEGRATED CIRCUITS..... | 82 |
| Dr. P. GEETHA | |
| CHAPTER 7 PROGRAMMABLE LOGIC DEVICES..... | 96 |
| S. LILLYPET | |
| CHAPTER 8 IMPLEMENTATION OF COMBINATIONAL LOGIC CIRCUITS..... | 108 |
| R. SARASWATHI | |
| CHAPTER 9 FIELD PROGRAMMABLE GATE ARRAYS..... | 120 |
| D. HARIKRISHNAN | |
| CHAPTER 10 APPLICATIONS | 132 |
| A. AMUDHA | |
| REFERENCES..... | 145 |

CHAPTER 1 DIGITAL FUNDAMENTALS

T. DIVYA MANOHARI

*Assistant Professor, Department of Electronics and Communication Engineering
Ponnaiyah Ramajayam Institute of Science and Technology, Tamil Nadu, India.*

Digital fundamentals encompass the essential concepts and principles that form the basis of digital systems and technologies. These principles are crucial for grasping how digital devices, like computers and smartphones, handle and process information. Here are some core concepts in digital fundamentals:

1. **Binary System:** Digital systems rely on the binary (base-2) number system, which uses only two digits: 0 and 1. Each binary digit is known as a bit. This binary code is the cornerstone of data representation in digital systems.
2. **Boolean Algebra:** Boolean algebra involves variables that can have one of two values: true or false (or 1 and 0 in binary). It is instrumental in designing and analyzing digital circuits. Basic Boolean operations include AND, OR, and NOT.
3. **Digital Logic Gates:** These fundamental components of digital circuits include:
 - **AND Gate:** Outputs 1 only when both inputs are 1.
 - **OR Gate:** Outputs 1 if at least one input is 1.
 - **NOT Gate (Inverter):** Outputs the inverse of the input (1 becomes 0, and 0 becomes 1).
 - **NAND Gate:** Outputs 0 only if both inputs are 1.
 - **NOR Gate:** Outputs 1 only if both inputs are 0.
 - **XOR Gate:** Outputs 1 if the inputs differ.
4. **Combinational Logic:** This refers to circuits where the output is determined solely by the current input values. Examples include adders, multiplexers, and encoders.
5. **Sequential Logic:** Involves circuits where the output depends on both the current input values and the historical sequence of inputs. Examples include flip-flops, counters, and memory devices.
6. **Flip-Flops:** Basic storage elements in digital electronics that store a single bit of data. Common types are SR (Set-Reset) flip-flops, D (Data) flip-flops, and JK flip-flops.
7. **Registers and Memory:** Registers temporarily store multiple bits of data.

CHAPTER 2 COMBINATIONAL CIRCUIT DESIGN

Dr. SMITHA ELSA PETER

Professor, Department of Electronics and Communication Engineering

Ponnaiyah Ramajayam Institute of Science and Technology, Tamil Nadu, India.

Combinational Circuit Design involves creating circuits where the output depends solely on the current inputs, with no memory or storage elements involved. These circuits perform logical operations based on the present values of the inputs and lack feedback loops.

Key Concepts in Combinational Circuit Design

1. Logic Gates:

- Basic Gates: AND, OR, NOT
- Derived Gates: NAND, NOR, XOR, XNOR
- These fundamental gates serve as the building blocks for constructing combinational circuits.

2. Boolean Algebra:

- Boolean Functions: Define the relationships between inputs and outputs. Examples include operations like AND, OR, and NOT.
- Simplification: Boolean expressions can be simplified using Boolean algebra rules and theorems to reduce the number of gates and components in the circuit.

3. Truth Tables:

- A truth table enumerates all possible input combinations and their corresponding outputs for a given Boolean function or logic circuit, aiding in both design and verification.

4. Karnaugh Maps (K-Maps):

- A graphical tool for simplifying Boolean expressions and minimizing the number of logic gates required. K-Maps facilitate the visualization and reduction of Boolean functions.

5. Design Procedure:

- Define the Problem: Specify the desired outputs for the given inputs.
- Derive the Boolean Expression: Formulate a Boolean equation based on the problem requirements.

CHAPTER 3 SYNCHRONOUS SEQUENTIAL CIRCUITS

R. SAVITHA

*Assistant Professor, Department of Electronics and Communication Engineering
Ponnaiyah Ramajayam Institute of Science and Technology, Tamil Nadu, India.*

Synchronous Sequential Circuits are digital circuits where operations are synchronized by a clock signal. This clock ensures that state changes occur at predictable intervals, promoting consistent and reliable circuit behavior.

Key Concepts in Synchronous Sequential Circuits

1. **Clock Signal:**

- A periodic signal that synchronizes the circuit's operations. It dictates when state changes and data transfers occur.

2. **State:**

- The condition of the circuit at any given time, represented by the values stored in flip-flops or memory elements. The state depends on the inputs and the current state.

3. **Flip-Flops:**

- Storage elements that hold binary information. Common types include D (Data), T (Toggle), JK, and SR (Set-Reset) flip-flops. These are edge-triggered and change states based on the clock signal.

4. **State Transition:**

- The process of moving from one state to another based on inputs and the current state. This transition is synchronized with the clock signal.

5. **State Diagram:**

- A graphical representation showing all possible states, transitions between states, and the conditions triggering these transitions.

6. **State Table:**

- A tabular representation listing all possible states, inputs, next states, and outputs. It helps in understanding and designing state transitions and output logic.

7. **Output Logic:**

- Logic that determines the circuit's output based on the current state and inputs. In synchronous sequential circuits.

CHAPTER 4 ASYNCHRONOUS SEQUENTIAL CIRCUITS

Dr. S. DEVI

Professor, Department of Electronics and Communication Engineering

Ponnaiyah Ramajayam Institute of Science and Technology, Tamil Nadu, India.

Asynchronous Sequential Circuits are digital circuits in which state transitions occur independently of a global clock signal. Unlike synchronous circuits that rely on a clock to synchronize changes, asynchronous sequential circuits respond to changes in input signals directly, allowing them to react more quickly. These circuits are often employed where exact timing control is less critical but require careful design to ensure reliable operation.

Key Concepts in Asynchronous Sequential Circuits

1. No Global Clock:

- Asynchronous circuits operate without a global clock. State changes are driven directly by input signal changes.

2. State Changes:

- Transitions between states occur immediately in response to input changes, potentially offering faster responses but also posing challenges for stability.

3. Hazards and Glitches:

- These circuits can experience hazards (unwanted transient changes in output) and glitches (brief errors caused by input changes). Effective design is crucial to mitigate these issues.

4. Race Conditions:

- Race conditions arise when the timing of state changes can lead to unpredictable behavior. Proper design and analysis are needed to ensure predictable and reliable state transitions.

5. Stable States:

- Asynchronous circuits aim to achieve stable states where outputs remain constant until a new input change occurs. Ensuring proper stabilization is key for reliable operation.

6. State Diagram and State Table:

- Asynchronous circuits utilize state diagrams and state tables to represent states.

CHAPTER 5 MEMORY DEVICES

S. MAHESHWARAN

*Assistant Professor, Department of Electronics and Communication Engineering
Ponnaiyah Ramajayam Institute of Science and Technology, Tamil Nadu, India.*

Memory devices are crucial components in digital systems, responsible for storing data and instructions. They vary in type and configuration, each tailored to specific applications based on factors like speed, capacity, volatility, and access methods. Here's an overview of the main types of memory devices and their attributes:

Types of Memory Devices

1. Volatile Memory

- **Definition:** Memory that requires a constant power supply to retain stored information. Data is lost when the power is removed.
- **Types:**
 - **Random Access Memory (RAM):**
 - **Dynamic RAM (DRAM):**
 - Stores data as charges in capacitors.
 - Requires periodic refreshing to maintain data.
 - Commonly used as the main system memory in computers.
 - **Static RAM (SRAM):**
 - Stores data using flip-flops.
 - Faster and more expensive than DRAM.
 - Typically used for cache memory in processors.
 - **Cache Memory:**
 - A high-speed memory located close to the CPU.
 - Holds frequently accessed data to enhance processing speed.
 - Typically organized in levels: L1 (closest to the CPU), L2, and sometimes L3 (larger and further from the CPU).

2. Non-Volatile Memory

- **Definition:** Memory that retains data even when power is off, making it suitable for long-term data storage.

CHAPTER 6 DIGITAL INTEGRATED CIRCUITS

Dr. P. GEETHA

Assistant Professor, Department of Electronics and Communication Engineering

Ponnaiyah Ramajayam Institute of Science and Technology, Tamil Nadu, India.

Digital integrated circuits (ICs) are foundational components in modern electronics, enabling sophisticated digital functions within compact, efficient packages.

These circuits consolidate various electronic elements, such as transistors, resistors, and capacitors, onto a single semiconductor chip.

Types of Digital Integrated Circuits

1. Logic Gates

- **Definition:** Fundamental building blocks for digital circuits that execute basic logic operations.
- **Types:**
 - **AND Gate:** Outputs true (1) only when all inputs are true.
 - **OR Gate:** Outputs true if at least one input is true.
 - **NOT Gate (Inverter):** Outputs the opposite value of the input.
 - **NAND Gate:** Outputs false only if all inputs are true.
 - **NOR Gate:** Outputs true only when all inputs are false.
 - **XOR Gate:** Outputs true if the number of true inputs is odd.
 - **XNOR Gate:** Outputs true if the number of true inputs is even.

2. Combinational Logic ICs

- **Definition:** ICs that implement combinational logic functions where the output is determined solely by the current inputs.
- **Types:**
 - **Adders:**
 - **Half Adder:** Adds two single-bit numbers, producing a sum and a carry output.
 - **Full Adder:** Adds three single-bit numbers (including a carry-in), providing a sum and a carry-out output.
 - **Multiplexers (MUX):** Select one of several input signals and route it to a single output based on control signals.

CHAPTER 7 PROGRAMMABLE LOGIC DEVICES

S. LILLYPET

Associate Professor, Department of Electronics and Communication Engineering

Ponnaiyah Ramajayam Institute of Science and Technology, Tamil Nadu, India.

Programmable Logic Devices (PLDs) are flexible components used in digital circuit design to create custom logic functions. Unlike fixed logic ICs, PLDs can be programmed to perform a wide range of functions, making them highly valuable for both simple and complex digital applications.

Types of Programmable Logic Devices

1. Programmable Logic Array (PLA)

- **Definition:** A PLD with both a programmable AND array and a programmable OR array, allowing for the creation of complex combinational logic functions.
- **Structure:**
 - **Input Lines:** Feed into the programmable AND array where they are combined.
 - **AND Array:** Generates product terms by performing AND operations on the inputs.
 - **OR Array:** Combines the product terms from the AND array to produce the final output.
- **Features:**
 - **Flexibility:** Can implement any combinational logic function due to the programmability of both AND and OR arrays.
 - **Customizability:** Offers high customization, allowing users to define both the product terms and the final output logic.
- **Applications:** Ideal for implementing complex custom logic functions and small-scale integration projects.

2. Programmable Array Logic (PAL)

- **Definition:** A PLD with a fixed OR array and a programmable AND array. This design simplifies the implementation of combinational logic functions.
- **Structure:**
 - **Fixed OR Array:** The OR array is predetermined and cannot be changed by the user.
 - **Programmable AND Array:** Allows users to configure the AND array to generate the necessary product terms.

CHAPTER 8 IMPLEMENTATION OF COMBINATIONAL LOGIC CIRCUITS

R. SARASWATHI

Assistant Professor, Department of Electronics and Communication Engineering

Ponnaiyah Ramajayam Institute of Science and Technology, Tamil Nadu, India.

Implementation of Combinational Logic Circuits involves creating circuits where the output depends solely on the current inputs, with no memory elements or feedback loops. The objective is to design circuits that perform specific logical functions based on the given input combinations.

Steps for Implementing Combinational Logic Circuits

1. Define the Problem

- **Determine Requirements:** Clearly identify the output needed for each possible combination of inputs.
- **Understand Functionality:** Define the logical operations the circuit must perform, such as addition, subtraction, or data selection.

2. Derive the Boolean Expression

- **Create a Truth Table:** List all possible input combinations along with their corresponding outputs to establish a clear relationship between inputs and outputs.
- **Formulate Boolean Expression:** Convert the truth table into a Boolean expression that describes the circuit's behavior.

3. Simplify the Boolean Expression

- **Apply Boolean Algebra:** Use Boolean algebra rules and properties to simplify the expression, which helps in reducing the circuit's complexity and the number of gates required.
- **Use Karnaugh Maps (K-Maps):** Employ Karnaugh maps to further simplify and minimize Boolean expressions by grouping adjacent cells in the truth table.

4. Design the Circuit

- **Select Logic Gates:** Choose the appropriate logic gates (AND, OR, NOT, NAND, NOR, XOR, XNOR) based on the simplified Boolean expression.
- **Draw the Logic Diagram:** Create a schematic diagram that shows how the selected gates are interconnected to implement the Boolean function.
- **Build the Circuit:** Construct the physical circuit using logic gates on a breadboard or integrate the design into a circuit board or digital simulation environment.

CHAPTER 9 FIELD PROGRAMMABLE GATE ARRAY

D. HARIKRISHNAN

Assistant Professor, Department of Electronics and Communication Engineering

Ponnaiyah Ramajayam Institute of Science and Technology, Tamil Nadu, India.

Field Programmable Gate Arrays (FPGAs) are versatile integrated circuits that can be customized and reprogrammed to perform a broad spectrum of digital functions. Unlike fixed logic devices, FPGAs offer the flexibility to be tailored for specific logic operations, making them suitable for applications ranging from basic logic tasks to complex digital systems.

Key Features of FPGAs

1. Programmability

- **Reconfigurability:** FPGAs can be programmed and reprogrammed multiple times, allowing users to modify their functionality as needed. This feature provides flexibility in design and the capability to update or correct designs even after they are deployed.
- **Hardware Description Languages (HDLs):** Programming is typically done using HDLs like VHDL or Verilog, which enable designers to specify the desired logic functions and behavior of the FPGA.

2. Architecture

- **Configurable Logic Blocks (CLBs):** CLBs are fundamental building blocks within an FPGA. They consist of logic gates, flip-flops, and multiplexers that can be configured to execute various logic operations.
- **Look-Up Tables (LUTs):** LUTs within CLBs implement logic functions by storing precomputed values. They can be configured to perform different logic operations based on input signals.
- **Flip-Flops:** These elements are used for data storage and implementing sequential logic functions.
- **Interconnects:** Programmable routing resources that enable connections between CLBs and other components within the FPGA, facilitating flexible data paths and connections.

3. Applications

- **Digital Signal Processing (DSP):** FPGAs excel in high-speed processing tasks, making them ideal for applications such as image and audio processing.

CHAPTER 10 APPLICATIONS

A. AMUDHA

Assistant Professor, Department of Electronics and Communication Engineering

Ponnaiyah Ramajayam Institute of Science and Technology, Tamil Nadu, India.

Digital electronics have fundamentally transformed technology and are integral to many modern applications. Here's a detailed look at key areas where digital electronics are extensively used:

1. Computing and Information Technology

- **Personal Computers:** Serve as the foundation of modern computing, with digital electronics powering CPUs, memory, and peripheral devices.
- **Servers and Data Centers:** Manage large-scale data processing and storage, essential for cloud computing and enterprise operations.
- **Laptops and Tablets:** Portable computing devices that leverage advanced digital technology for performance and functionality.

2. Consumer Electronics

- **Smartphones:** Feature digital processors, touchscreens, and sensors, enabling a wide range of functionalities from communication to entertainment.
- **Televisions:** Use digital signal processing for high-definition video and integrated smart features.
- **Audio Equipment:** Incorporate digital signal processing for enhanced sound quality in speakers, headphones, and home audio systems.

3. Telecommunications

- **Networking Equipment:** Includes routers, switches, and modems, which handle digital data transmission and processing for internet and communication networks.
- **Cellular Networks:** Employ digital signals for communication between base stations and mobile devices.
- **Satellite Communications:** Utilize digital electronics for encoding, transmitting, and decoding data in satellite systems.

4. Automotive

- **Engine Control Units (ECUs):** Oversee critical functions such as fuel injection, ignition timing, and emission controls using digital technology.



DIGITAL SYSTEMS DESIGN

Edited by
S.SARASHWATHI



978-93-6255-082-8

DIGITAL SYSTEMS DESIGN

Copyright @ 2023 by S. SARASWATHI

All rights reserved. No part of this book may be reproduced or transmitted in any form or by any means without written permission from the author.

ISBN: 9789362550828

Publisher: Ponnaiyah Ramajayam Institute of Science and Technology (PRIST)

TABLE OF CONTENTS

| CHAPTER | CONTENT | PAGE |
|----------------|--|-------------|
| | INTRODUCTION | 3 |
| 1 | DIGITAL FUNDAMENTALS D.HARIKRISHNAN | 6 |
| 2 | COMBINATIONAL CIRCUIT DESIGN R. SARASWATHI | 21 |
| 3 | SYNCHRONOUS SEQUENTIAL CIRCUITS Dr. P. GEETHA | 35 |
| 4 | ASYNCHRONOUS SEQUENTIAL CIRCUITS R. SAVITHA | 50 |
| 5 | MEMORY DEVICES S. MAHESHWARAN | 69 |
| 6 | DIGITAL INTEGRATED CIRCUITS A.AARTHI | 83 |
| 7 | PROGRAMMABLE LOGIC DEVICES S. LILLYPET | 97 |
| 8 | IMPLEMENTATION OF COMBINATIONAL LOGIC CIRCUITS Dr. SMITHA ELSA PETER | 109 |
| 9 | FIELD PROGRAMMABLE GATE ARRAYS T. DIVYA MANOHARI | 121 |
| 10 | HAZARDS Dr. N. PARVATHAM | 133 |
| 11 | LOGIC FAMILIES Dr. C. RAJINIKANTH | 146 |
| 12 | APPLICATIONS A. AMUDHA | 160 |
| | REFERENCES | 171 |

CHAPTER 1 DIGITAL FUNDAMENTALS

D. HARIKRISHNAN

*Assistant Professor, Department of Electronics and Communication Engineering
Ponnaiyah Ramajayam Institute of Science and Technology, Tamil Nadu, India.*

Digital fundamentals encompass the essential concepts and principles that form the basis of digital systems and technologies. These principles are crucial for grasping how digital devices, like computers and smartphones, handle and process information. Here are some core concepts in digital fundamentals:

1. **Binary System:** Digital systems rely on the binary (base-2) number system, which uses only two digits: 0 and 1. Each binary digit is known as a bit. This binary code is the cornerstone of data representation in digital systems.
2. **Boolean Algebra:** Boolean algebra involves variables that can have one of two values: true or false (or 1 and 0 in binary). It is instrumental in designing and analyzing digital circuits. Basic Boolean operations include AND, OR, and NOT.
3. **Digital Logic Gates:** These fundamental components of digital circuits include:
 - **AND Gate:** Outputs 1 only when both inputs are 1.
 - **OR Gate:** Outputs 1 if at least one input is 1.
 - **NOT Gate (Inverter):** Outputs the inverse of the input (1 becomes 0, and 0 becomes 1).
 - **NAND Gate:** Outputs 0 only if both inputs are 1.
 - **NOR Gate:** Outputs 1 only if both inputs are 0.
 - **XOR Gate:** Outputs 1 if the inputs differ.
4. **Combinational Logic:** This refers to circuits where the output is determined solely by the current input values. Examples include adders, multiplexers, and encoders.
5. **Sequential Logic:** Involves circuits where the output depends on both the current input values and the historical sequence of inputs. Examples include flip-flops, counters, and memory devices.
6. **Flip-Flops:** Basic storage elements in digital electronics that store a single bit of data. Common types are SR (Set-Reset) flip-flops, D (Data) flip-flops, and JK flip-flops.
7. **Registers and Memory:** Registers temporarily store multiple bits of data.

CHAPTER 2 COMBINATIONAL CIRCUIT DESIGN

R.SARASWATHI

*Assistant Professor, Department of Electronics and Communication Engineering
Ponnaiyah Ramajayam Institute of Science and Technology, Tamil Nadu, India.*

Combinational Circuit Design involves creating circuits where the output depends solely on the current inputs, with no memory or storage elements involved. These circuits perform logical operations based on the present values of the inputs and lack feedback loops.

Key Concepts in Combinational Circuit Design

1. Logic Gates:

- Basic Gates: AND, OR, NOT
- Derived Gates: NAND, NOR, XOR, XNOR
- These fundamental gates serve as the building blocks for constructing combinational circuits.

2. Boolean Algebra:

- Boolean Functions: Define the relationships between inputs and outputs. Examples include operations like AND, OR, and NOT.
- Simplification: Boolean expressions can be simplified using Boolean algebra rules and theorems to reduce the number of gates and components in the circuit.

3. Truth Tables:

- A truth table enumerates all possible input combinations and their corresponding outputs for a given Boolean function or logic circuit, aiding in both design and verification.

4. Karnaugh Maps (K-Maps):

- A graphical tool for simplifying Boolean expressions and minimizing the number of logic gates required. K-Maps facilitate the visualization and reduction of Boolean functions.

5. Design Procedure:

- Define the Problem: Specify the desired outputs for the given inputs.
- Derive the Boolean Expression: Formulate a Boolean equation based on the problem requirements.

CHAPTER 3 SYNCHRONOUS SEQUENTIAL CIRCUITS

Dr. P. GEETHA

*Assistant Professor, Department of Electronics and Communication Engineering
Ponnaiyah Ramajayam Institute of Science and Technology, Tamil Nadu, India.*

Synchronous Sequential Circuits are digital circuits where operations are synchronized by a clock signal. This clock ensures that state changes occur at predictable intervals, promoting consistent and reliable circuit behavior.

Key Concepts in Synchronous Sequential Circuits

1. Clock Signal:

- A periodic signal that synchronizes the circuit's operations. It dictates when state changes and data transfers occur.

2. State:

- The condition of the circuit at any given time, represented by the values stored in flip-flops or memory elements. The state depends on the inputs and the current state.

3. Flip-Flops:

- Storage elements that hold binary information. Common types include D (Data), T (Toggle), JK, and SR (Set-Reset) flip-flops. These are edge-triggered and change states based on the clock signal.

4. State Transition:

- The process of moving from one state to another based on inputs and the current state. This transition is synchronized with the clock signal.

5. State Diagram:

- A graphical representation showing all possible states, transitions between states, and the conditions triggering these transitions.

6. State Table:

- A tabular representation listing all possible states, inputs, next states, and outputs. It helps in understanding and designing state transitions and output logic.

7. Output Logic:

- Logic that determines the circuit's output based on the current state and inputs. In synchronous sequential circuits.

CHAPTER 4 ASYNCHRONOUS SEQUENTIAL CIRCUITS

R. SAVITHA

*Assistant Professor, Department of Electronics and Communication Engineering
Ponnaiyah Ramajayam Institute of Science and Technology, Tamil Nadu, India.*

Asynchronous Sequential Circuits are digital circuits in which state transitions occur independently of a global clock signal. Unlike synchronous circuits that rely on a clock to synchronize changes, asynchronous sequential circuits respond to changes in input signals directly, allowing them to react more quickly. These circuits are often employed where exact timing control is less critical but require careful design to ensure reliable operation.

Key Concepts in Asynchronous Sequential Circuits

1. **No Global Clock:**

- Asynchronous circuits operate without a global clock. State changes are driven directly by input signal changes.

2. **State Changes:**

- Transitions between states occur immediately in response to input changes, potentially offering faster responses but also posing challenges for stability.

3. **Hazards and Glitches:**

- These circuits can experience hazards (unwanted transient changes in output) and glitches (brief errors caused by input changes). Effective design is crucial to mitigate these issues.

4. **Race Conditions:**

- Race conditions arise when the timing of state changes can lead to unpredictable behavior. Proper design and analysis are needed to ensure predictable and reliable state transitions.

5. **Stable States:**

- Asynchronous circuits aim to achieve stable states where outputs remain constant until a new input change occurs. Ensuring proper stabilization is key for reliable operation.

6. **State Diagram and State Table:**

- Asynchronous circuits utilize state diagrams and state tables to represent states.

CHAPTER 5 MEMORY DEVICES

S. MAHESHWARAN

*Assistant Professor, Department of Electronics and Communication Engineering
Ponnaiyah Ramajayam Institute of Science and Technology, Tamil Nadu, India.*

Memory devices are crucial components in digital systems, responsible for storing data and instructions. They vary in type and configuration, each tailored to specific applications based on factors like speed, capacity, volatility, and access methods. Here's an overview of the main types of memory devices and their attributes:

Types of Memory Devices

1. Volatile Memory

- **Definition:** Memory that requires a constant power supply to retain stored information. Data is lost when the power is removed.
- **Types:**
 - **Random Access Memory (RAM):**
 - **Dynamic RAM (DRAM):**
 - Stores data as charges in capacitors.
 - Requires periodic refreshing to maintain data.
 - Commonly used as the main system memory in computers.
 - **Static RAM (SRAM):**
 - Stores data using flip-flops.
 - Faster and more expensive than DRAM.
 - Typically used for cache memory in processors.
 - **Cache Memory:**
 - A high-speed memory located close to the CPU.
 - Holds frequently accessed data to enhance processing speed.
 - Typically organized in levels: L1 (closest to the CPU), L2, and sometimes L3 (larger and further from the CPU).

2. Non-Volatile Memory

- **Definition:** Memory that retains data even when power is off, making it suitable for long-term data storage.

CHAPTER 6 DIGITAL INTEGRATED CIRCUITS

A. AARTHI

Assistant Professor, Department of Electronics and Communication Engineering

Ponnaiyah Ramajayam Institute of Science and Technology, Tamil Nadu, India.

Digital integrated circuits (ICs) are foundational components in modern electronics, enabling sophisticated digital functions within compact, efficient packages.

These circuits consolidate various electronic elements, such as transistors, resistors, and capacitors, onto a single semiconductor chip.

Types of Digital Integrated Circuits

1. Logic Gates

- **Definition:** Fundamental building blocks for digital circuits that execute basic logic operations.
- **Types:**
 - **AND Gate:** Outputs true (1) only when all inputs are true.
 - **OR Gate:** Outputs true if at least one input is true.
 - **NOT Gate (Inverter):** Outputs the opposite value of the input.
 - **NAND Gate:** Outputs false only if all inputs are true.
 - **NOR Gate:** Outputs true only when all inputs are false.
 - **XOR Gate:** Outputs true if the number of true inputs is odd.
 - **XNOR Gate:** Outputs true if the number of true inputs is even.

2. Combinational Logic ICs

- **Definition:** ICs that implement combinational logic functions where the output is determined solely by the current inputs.
- **Types:**
 - **Adders:**
 - **Half Adder:** Adds two single-bit numbers, producing a sum and a carry output.
 - **Full Adder:** Adds three single-bit numbers (including a carry-in), providing a sum and a carry-out output.
 - **Multiplexers (MUX):** Select one of several input signals and route it to a single output based on control signals.

CHAPTER 7 PROGRAMMABLE LOGIC DEVICES

S. LILLYPET

Associate Professor, Department of Electronics and Communication Engineering

Ponnaiyah Ramajayam Institute of Science and Technology, Tamil Nadu, India.

Programmable Logic Devices (PLDs) are flexible components used in digital circuit design to create custom logic functions. Unlike fixed logic ICs, PLDs can be programmed to perform a wide range of functions, making them highly valuable for both simple and complex digital applications.

Types of Programmable Logic Devices

1. Programmable Logic Array (PLA)

- **Definition:** A PLD with both a programmable AND array and a programmable OR array, allowing for the creation of complex combinational logic functions.
- **Structure:**
 - **Input Lines:** Feed into the programmable AND array where they are combined.
 - **AND Array:** Generates product terms by performing AND operations on the inputs.
 - **OR Array:** Combines the product terms from the AND array to produce the final output.
- **Features:**
 - **Flexibility:** Can implement any combinational logic function due to the programmability of both AND and OR arrays.
 - **Customizability:** Offers high customization, allowing users to define both the product terms and the final output logic.
- **Applications:** Ideal for implementing complex custom logic functions and small-scale integration projects.

2. Programmable Array Logic (PAL)

- **Definition:** A PLD with a fixed OR array and a programmable AND array. This design simplifies the implementation of combinational logic functions.
- **Structure:**
 - **Fixed OR Array:** The OR array is predetermined and cannot be changed by the user.
 - **Programmable AND Array:** Allows users to configure the AND array to generate the necessary product terms.

CHAPTER 8 IMPLEMENTATION OF COMBINATIONAL LOGIC CIRCUITS

Dr. SMITHA ELSA PETER

Professor, Department of Electronics and Communication Engineering

Ponnaiyah Ramajayam Institute of Science and Technology, Tamil Nadu, India.

Implementation of Combinational Logic Circuits involves creating circuits where the output depends solely on the current inputs, with no memory elements or feedback loops. The objective is to design circuits that perform specific logical functions based on the given input combinations.

Steps for Implementing Combinational Logic Circuits

1. Define the Problem

- **Determine Requirements:** Clearly identify the output needed for each possible combination of inputs.
- **Understand Functionality:** Define the logical operations the circuit must perform, such as addition, subtraction, or data selection.

2. Derive the Boolean Expression

- **Create a Truth Table:** List all possible input combinations along with their corresponding outputs to establish a clear relationship between inputs and outputs.
- **Formulate Boolean Expression:** Convert the truth table into a Boolean expression that describes the circuit's behavior.

3. Simplify the Boolean Expression

- **Apply Boolean Algebra:** Use Boolean algebra rules and properties to simplify the expression, which helps in reducing the circuit's complexity and the number of gates required.
- **Use Karnaugh Maps (K-Maps):** Employ Karnaugh maps to further simplify and minimize Boolean expressions by grouping adjacent cells in the truth table.

4. Design the Circuit

- **Select Logic Gates:** Choose the appropriate logic gates (AND, OR, NOT, NAND, NOR, XOR, XNOR) based on the simplified Boolean expression.
- **Draw the Logic Diagram:** Create a schematic diagram that shows how the selected gates are interconnected to implement the Boolean function.
- **Build the Circuit:** Construct the physical circuit using logic gates on a breadboard or integrate the design into a circuit board or digital simulation environment.

CHAPTER 9 FIELD PROGRAMMABLE GATE ARRAY

T. DIVYA MANOHARI

Assistant Professor, Department of Electronics and Communication Engineering

Ponnaiyah Ramajayam Institute of Science and Technology, Tamil Nadu, India.

Field Programmable Gate Arrays (FPGAs) are versatile integrated circuits that can be customized and reprogrammed to perform a broad spectrum of digital functions. Unlike fixed logic devices, FPGAs offer the flexibility to be tailored for specific logic operations, making them suitable for applications ranging from basic logic tasks to complex digital systems.

Key Features of FPGAs

1. Programmability

- **Reconfigurability:** FPGAs can be programmed and reprogrammed multiple times, allowing users to modify their functionality as needed. This feature provides flexibility in design and the capability to update or correct designs even after they are deployed.
- **Hardware Description Languages (HDLs):** Programming is typically done using HDLs like VHDL or Verilog, which enable designers to specify the desired logic functions and behavior of the FPGA.

2. Architecture

- **Configurable Logic Blocks (CLBs):** CLBs are fundamental building blocks within an FPGA. They consist of logic gates, flip-flops, and multiplexers that can be configured to execute various logic operations.
- **Look-Up Tables (LUTs):** LUTs within CLBs implement logic functions by storing precomputed values. They can be configured to perform different logic operations based on input signals.
- **Flip-Flops:** These elements are used for data storage and implementing sequential logic functions.
- **Interconnects:** Programmable routing resources that enable connections between CLBs and other components within the FPGA, facilitating flexible data paths and connections.

3. Applications

- **Digital Signal Processing (DSP):** FPGAs excel in high-speed processing tasks, making them ideal for applications such as image and audio processing.

CHAPTER 10 HAZARDS

Dr. N. PARVATHAM

*Associate Professor, Department of Electronics and Communication Engineering
Ponnaiyah Ramajayam Institute of Science and Technology, Tamil Nadu, India.*

In digital signal processing and system design, "hazards" refer to issues or risks that can affect system performance and reliability. These hazards can impact various stages of system operation.

1. Data Hazards

- **Definition:** Data hazards arise when instructions accessing the same data overlap, potentially causing conflicts or incorrect results.
- **Types:**
 - **Read-after-Write (RAW):** An instruction needs data that has not yet been written by a previous instruction.
 - **Write-after-Read (WAR):** An instruction writes to a location before a previous instruction has finished reading from it.
 - **Write-after-Write (WAW):** Two instructions write to the same location, and the order of these writes affects the outcome.

2. Control Hazards

- **Definition:** Control hazards, or branch hazards, occur when execution flow is altered by control instructions like branches or jumps.
- **Impact:** Can cause delays or incorrect execution if branch directions and outcomes are not correctly managed or predicted.

3. Timing Hazards

- **Definition:** Timing hazards occur due to discrepancies or delays in the expected timing of signal processing or system operations.
- **Impact:** Can lead to synchronization issues, incorrect data handling, or performance degradation, particularly critical in real-time systems.

4. Synchronization Hazards

- **Definition:** Arise in systems where multiple processes or threads need to coordinate or share resources.
- **Impact:** Poor synchronization can lead to race conditions, unpredictable behavior, or deadlock.

CHAPTER 11 LOGIC FAMILIES

Dr. C. RAJINIKANTH

*Associate Professor, Department of Electronics and Communication Engineering
Ponnaiyah Ramajayam Institute of Science and Technology, Tamil Nadu, India.*

Logic families are crucial in digital electronics, grouping circuits with similar technologies and characteristics that influence behavior, speed, power consumption, and overall performance.

1. Transistor-Transistor Logic (TTL)

- **Technology:** Employs bipolar junction transistors (BJTs) for both logic gates and amplification.
- **Characteristics:**
 - **Speed:** Moderate, with propagation delays in the nanosecond range.
 - **Power Consumption:** Higher than CMOS due to continuous current flow through transistors.
 - **Logic Levels:** Typically 0V for logic 0 and 5V for logic 1.
 - **Variants:** Includes Standard TTL, Schottky TTL (STTL), and Low-Power TTL (LPTTL).
- **Applications:** Common in older digital systems and some embedded applications.

2. Complementary Metal-Oxide-Semiconductor (CMOS)

- **Technology:** Utilizes both p-type and n-type MOSFETs (metal-oxide-semiconductor field-effect transistors).
- **Characteristics:**
 - **Speed:** Fast, with propagation delays from picoseconds to nanoseconds.
 - **Power Consumption:** Very low compared to TTL, with power primarily used during switching.
 - **Logic Levels:** Generally 0V for logic 0 and 3.3V or 5V for logic 1, depending on the specific CMOS technology.
 - **Variants:** Includes Standard CMOS, Low-Power CMOS, and High-Speed CMOS (HC, HCT, AC, ACT).
- **Applications:** Prevalent in modern digital design due to low power consumption and high integration density.

CHAPTER 12 APPLICATIONS

A. AMUDHA

*Assistant Professor, Department of Electronics and Communication Engineering
Ponnaiyah Ramajayam Institute of Science and Technology, Tamil Nadu, India.*

Digital electronics have fundamentally transformed technology and are integral to many modern applications. Here's a detailed look at key areas where digital electronics are extensively used:

1. Computing and Information Technology

- **Personal Computers:** Serve as the foundation of modern computing, with digital electronics powering CPUs, memory, and peripheral devices.
- **Servers and Data Centers:** Manage large-scale data processing and storage, essential for cloud computing and enterprise operations.
- **Laptops and Tablets:** Portable computing devices that leverage advanced digital technology for performance and functionality.

2. Consumer Electronics

- **Smartphones:** Feature digital processors, touchscreens, and sensors, enabling a wide range of functionalities from communication to entertainment.
- **Televisions:** Use digital signal processing for high-definition video and integrated smart features.
- **Audio Equipment:** Incorporate digital signal processing for enhanced sound quality in speakers, headphones, and home audio systems.

3. Telecommunications

- **Networking Equipment:** Includes routers, switches, and modems, which handle digital data transmission and processing for internet and communication networks.
- **Cellular Networks:** Employ digital signals for communication between base stations and mobile devices.
- **Satellite Communications:** Utilize digital electronics for encoding, transmitting, and decoding data in satellite systems.

4. Automotive

- **Engine Control Units (ECUs):** Oversee critical functions such as fuel injection, ignition timing, and emission controls using digital technology.

DIGITAL SYSTEMS DESIGN LAB MANUAL

Edited by

BHARATHI.C



978-93-6255-843-5

DIGITAL SYSTEMS DESIGN LAB MANUAL

COPYRIGHT @ 2023 BY C.BHARATHI

ALL RIGHTS RESERVED. NO PART OF THIS BOOK MAY BE
REPRODUCED OR TRANSMITTED IN ANY FORM OR BY ANY MEANS
WITHOUT WRITTEN PERMISSION FROM THE AUTHOR.

ISBN: 978-93-6255-843-5

PUBLISHER: Ponnaiyah Ramajayam Institute of Science and Technology
(PRIST)

EXPERIMENT LIST:

| Exp. No | DATE | TITLE OF EXPERIMENTS | SIGNATURE |
|----------------|-------------|--|------------------|
| 1. | | Study of logic gates | |
| 2. | | Design and implementation of code converters using logic gates a) Binary to gray code converter and its vice versa b) Excess-3 to BCD converter and its vice versa | |
| 3. | | a) Design of adder and subtractor using logic gates b) Design of adder and subtractor using IC7483 c) Design of BCD adder using IC7483 | |
| 4. | | Design and implementation of Multiplexer and De- multiplexer using logic gates | |
| 5. | | Design and implementation of encoder and decoder using logic gates | |
| 6. | | Design and implementation of 3-bit synchronous up/down counter | |
| 7. | | Design and Implementation of shift registers. | |
| 8. | | Design and Implementation of 8-bit and 2- bit Magnitude Comparator | |

| | |
|-----------------|-----------------------------|
| Exp. No: | STUDY OF LOGIC GATES |
| Date: | |

AIM:

To study about logic gates and verify their truth tables.

APPARATUS REQUIRED:

| SL No. | COMPONENT | SPECIFICATION | QTY |
|--------|-----------------|---------------|-----|
| 1. | AND GATE | IC 7408 | 1 |
| 2. | OR GATE | IC 7432 | 1 |
| 3. | NOT GATE | IC 7404 | 1 |
| 4. | NAND GATE 2 I/P | IC 7400 | 1 |
| 5. | NOR GATE | IC 7402 | 1 |
| 6. | X-OR GATE | IC 7486 | 1 |
| 7. | NAND GATE 3 I/P | IC 7410 | 1 |
| 8. | IC TRAINER KIT | - | 1 |
| 9. | PATCH CORD | - | 14 |

THEORY:

Circuit that takes the logical decision and the process are called logic gates. Each gate has one or more input and only one output.

OR, AND and NOT are basic gates. NAND, NOR and X-OR are known as universal gates. Basic gates form these gates.

AND GATE:

The AND gate performs a logical multiplication commonly known as AND function. The output is high when both the inputs are high. The output is low level when any one of the inputs is low.

OR GATE:

The OR gate performs a logical addition commonly known as OR function. The output is high when any one of the inputs is high. The output is low level when both the inputs are low.

NOT GATE:

The NOT gate is called an inverter. The output is high when the input is low. The output is low when the input is high.

NAND GATE:

The NAND gate is a contraction of AND-NOT. The output is high when both inputs are low and any one of the input is low. The output is low level when both inputs are high.

NOR GATE:

The NOR gate is a contraction of OR-NOT. The output is high when both inputs are low. The output is low when one or both inputs are high.

X-OR GATE:

The output is high when any one of the inputs is high. The output is low when both the inputs are low and both the inputs are high.

PROCEDURE:

- (i) Connections are given as per circuit diagram.
- (ii) Logical inputs are given as per circuit diagram.
- (iii) Observe the output and verify the truth table.

AND GATE:

SYMBOL:

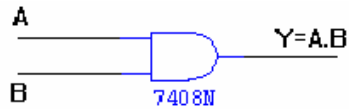

TRUTH TABLE

| A | B | A.B |
|---|---|-----|
| 0 | 0 | 0 |
| 0 | 1 | 0 |
| 1 | 0 | 0 |
| 1 | 1 | 1 |

PIN DIAGRAM:

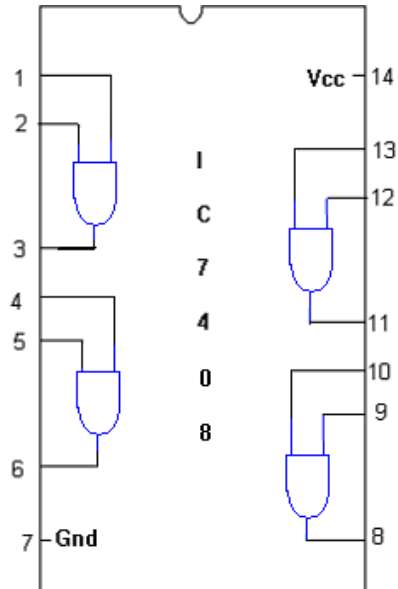

OR GATE:

SYMBOL :

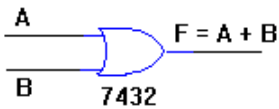

TRUTH TABLE

| A | B | A+B |
|---|---|-----|
| 0 | 0 | 0 |
| 0 | 1 | 1 |
| 1 | 0 | 1 |
| 1 | 1 | 1 |

PIN DIAGRAM :

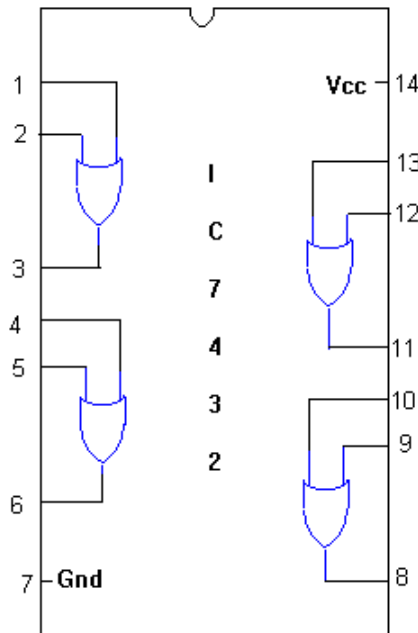

NOT GATE:

SYMBOL:



TRUTH TABLE :

| A | \bar{A} |
|---|-----------|
| 0 | 1 |
| 1 | 0 |

PIN DIAGRAM:

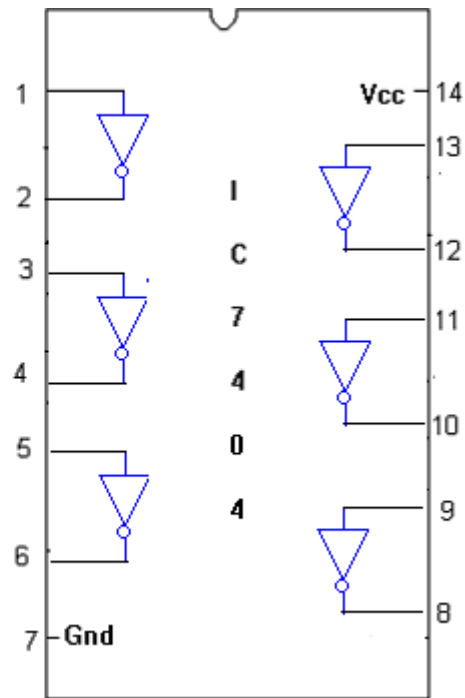

X-OR GATE :

SYMBOL:

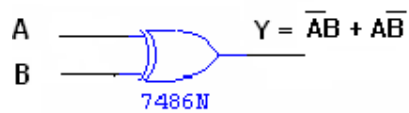

TRUTH TABLE :

| A | B | $\bar{A}B + A\bar{B}$ |
|---|---|-----------------------|
| 0 | 0 | 0 |
| 0 | 1 | 1 |
| 1 | 0 | 1 |
| 1 | 1 | 0 |

PIN DIAGRAM:

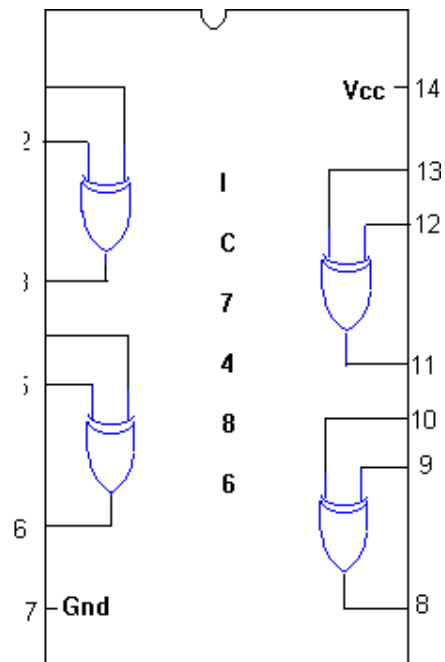

2-INPUT NAND GATE:

SYMBOL:

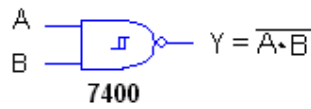

TRUTH TABLE

| A | B | $\overline{A \cdot B}$ |
|---|---|------------------------|
| 0 | 0 | 1 |
| 0 | 1 | 1 |
| 1 | 0 | 1 |
| 1 | 1 | 0 |

PIN DIAGRAM:

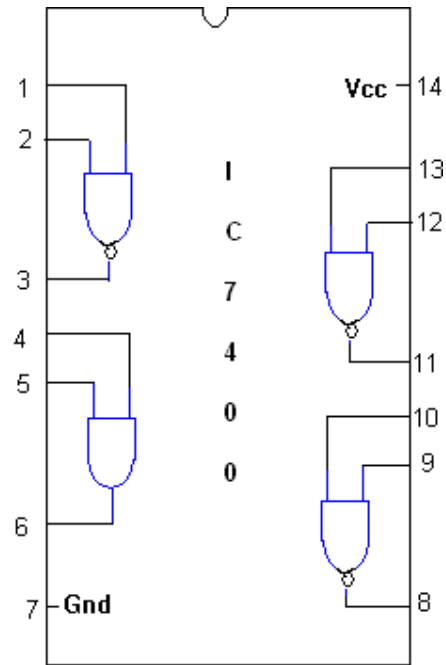

3-INPUT NAND GATE :

SYMBOL :

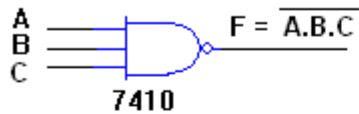

TRUTH TABLE

| A | B | C | $\overline{A \cdot B \cdot C}$ |
|---|---|---|--------------------------------|
| 0 | 0 | 0 | 1 |
| 0 | 0 | 1 | 1 |
| 0 | 1 | 0 | 1 |
| 0 | 1 | 1 | 1 |
| 1 | 0 | 0 | 1 |
| 1 | 0 | 1 | 1 |
| 1 | 1 | 0 | 1 |
| 1 | 1 | 1 | 0 |

PIN DIAGRAM :

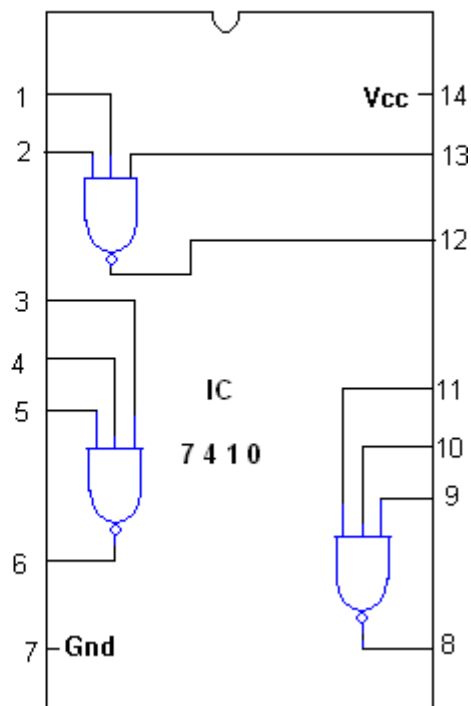

NOR GATE:

SYMBOL :

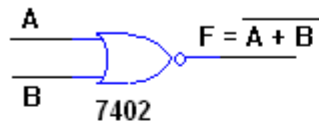

TRUTH TABLE

| A | B | $\overline{A+B}$ |
|---|---|------------------|
| 0 | 0 | 1 |
| 0 | 1 | 1 |
| 1 | 0 | 1 |
| 1 | 1 | 0 |

PIN DIAGRAM :

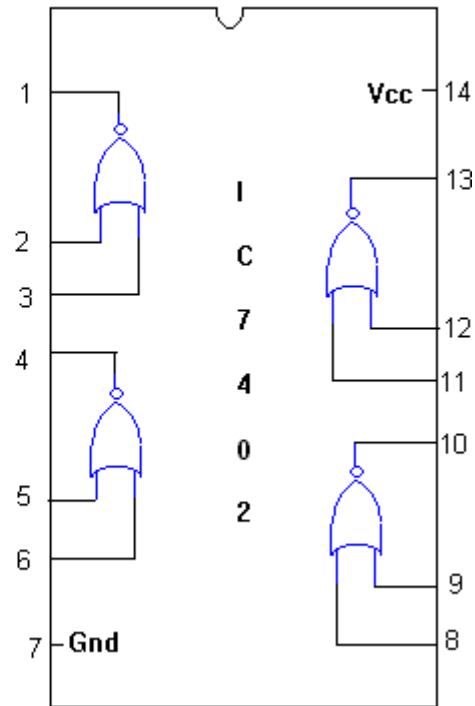

RESULT:

The logic gates are studied and its truth tables are verified.

| | |
|-----------------|---|
| Exp. No: | DESIGN AND IMPLEMENTATION OF CODE CONVERTER Binary to gray code converter and its vice versa |
| Date: | |

AIM:

To design and implement 4-bit

- (i) Binary to gray code converter
- (ii) Gray to binary code converter

APPARATUS REQUIRED:

| Sl.No. | COMPONENT | SPECIFICATION | QTY. |
|--------|----------------|---------------|------|
| 1. | X-OR GATE | IC 7486 | 1 |
| 2. | IC TRAINER KIT | - | 1 |
| 3. | PATCH CORDS | - | 10 |

THEORY:

The availability of large variety of codes for the same discrete elements of information results in the use of different codes by different systems. A conversion circuit must be inserted between the two systems if each uses different codes for same information. Thus, code converter is a circuit that makes the two systems compatible even though each uses different binary code.

The bit combination assigned to binary code to gray code. Since each code uses four bits to represent a decimal digit. There are four inputs and four outputs. Gray code is a non- weighted code.

The input variable are designated as B3, B2, B1, B0 and the output variables are designated as C3, C2, C1, Co. from the truth table, combinational circuit is designed. The Boolean functions are obtained from K-Map for each output variable.

A code converter is a circuit that makes the two systems compatible even though each uses a different binary code. To convert from binary code to Excess-3 code, the input lines must supply the bit combination of elements as specified by code and the output lines generate the corresponding bit combination of code. Each one of the four maps represents one of the four outputs of the circuit as a function of the four input variables.

A two-level logic diagram may be obtained directly from the Boolean expressions derived by the maps. These are various other possibilities for a logic diagram that implements this circuit. Now the OR gate whose output is C+D has been used to implement partially each of three outputs.

LOGIC DIAGRAM:

BINARY TO GRAY CODE CONVERTOR

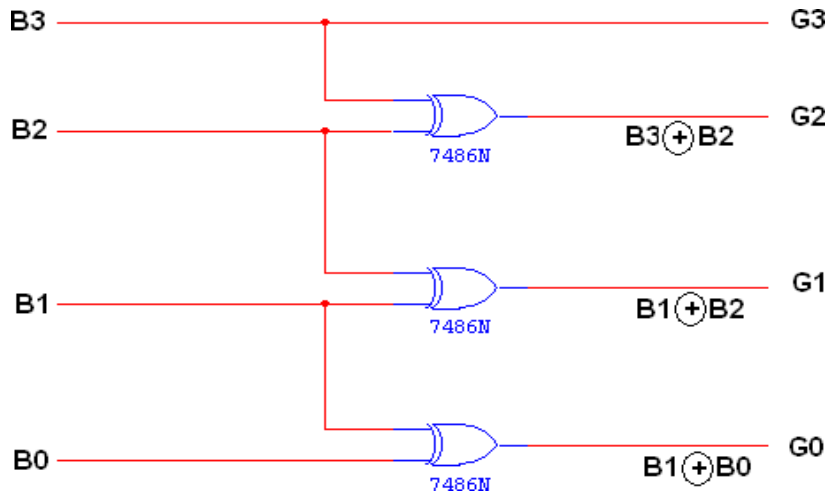

K-Map for G₃:

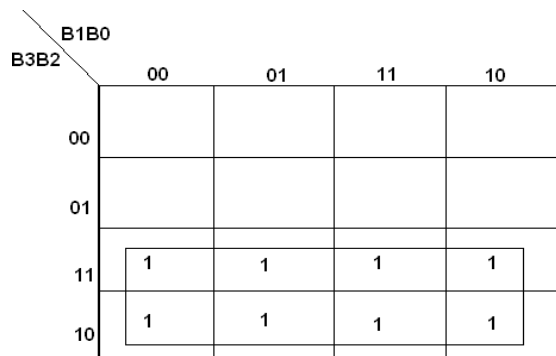

$G_3 = B_3$

K-Map for G₂:

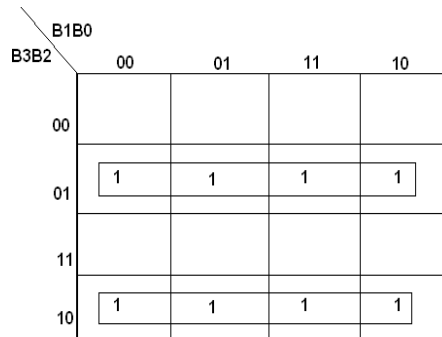

$G_2 = B_3 \oplus B_2$

K-Map for G₁:

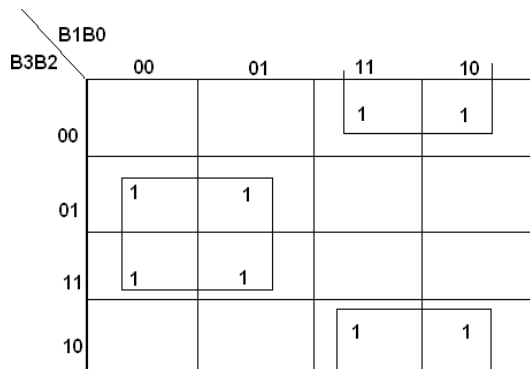

$G_1 = B_1 \oplus B_2$

K-Map for G₀:

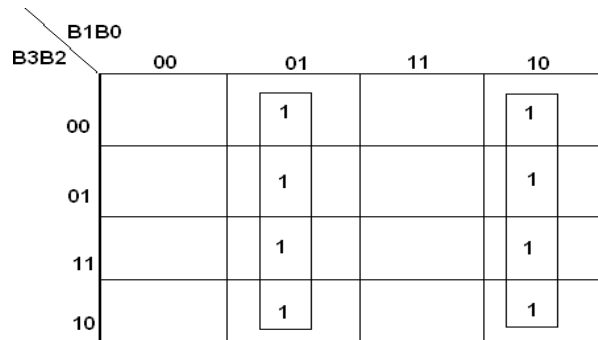

$G_0 = B_1 \oplus B_0$

TRUTH TABLE:

| Binary input | Gray code output |

| B3 | B2 | B1 | B0 | G3 | G2 | G1 | G0 |
|----|----|----|----|----|----|----|----|
| 0 | 0 | 0 | 0 | 0 | 0 | 0 | 0 |
| 0 | 0 | 0 | 1 | 0 | 0 | 0 | 1 |
| 0 | 0 | 1 | 0 | 0 | 0 | 1 | 1 |
| 0 | 0 | 1 | 1 | 0 | 0 | 1 | 0 |
| 0 | 1 | 0 | 0 | 0 | 1 | 1 | 0 |
| 0 | 1 | 0 | 1 | 0 | 1 | 1 | 1 |
| 0 | 1 | 1 | 0 | 0 | 1 | 0 | 1 |
| 0 | 1 | 1 | 1 | 0 | 1 | 0 | 0 |
| 1 | 0 | 0 | 0 | 1 | 1 | 0 | 0 |
| 1 | 0 | 0 | 1 | 1 | 1 | 0 | 1 |
| 1 | 0 | 1 | 0 | 1 | 1 | 1 | 1 |
| 1 | 0 | 1 | 1 | 1 | 1 | 1 | 0 |
| 1 | 1 | 0 | 0 | 1 | 0 | 1 | 0 |
| 1 | 1 | 0 | 1 | 1 | 0 | 1 | 1 |
| 1 | 1 | 1 | 0 | 1 | 0 | 0 | 1 |
| 1 | 1 | 1 | 1 | 1 | 0 | 0 | 0 |

LOGIC DIAGRAM:

GRAY CODE TO BINARY CONVERTOR

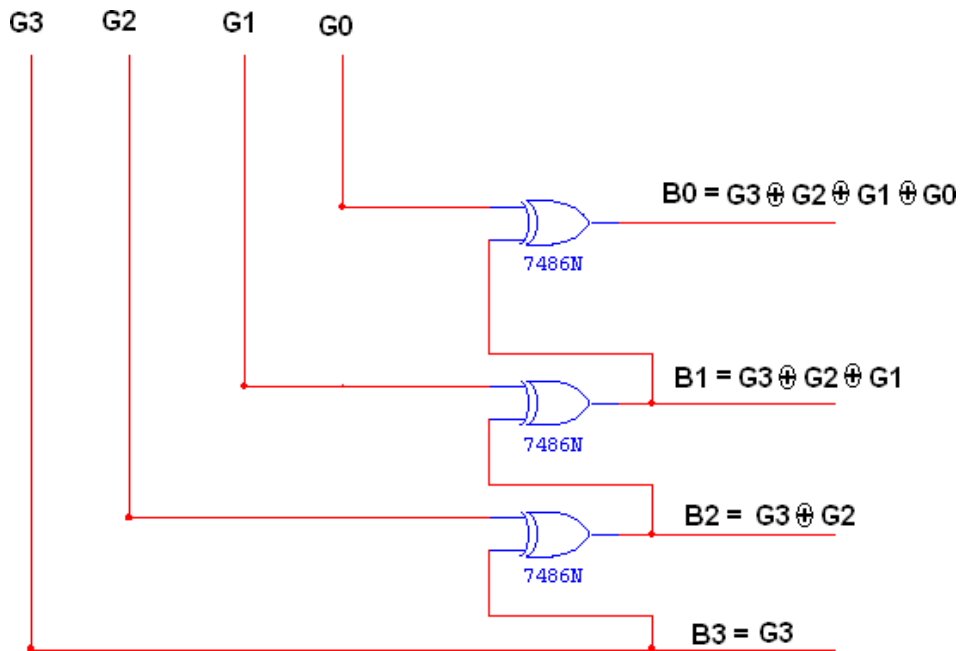

| | | | | | |
|------|----|------|----|----|----|
| | | G1G0 | | | |
| | | 00 | 01 | 11 | 10 |
| G3G2 | 00 | 0 | 0 | 0 | 0 |
| | 01 | 0 | 0 | 0 | 0 |
| | 11 | 1 | 1 | 1 | 1 |
| | 10 | 1 | 1 | 1 | 1 |

$$B3 = G3$$

K-Map for B₂:

| | | | | | |
|------|----|------|----|----|----|
| | | G1G0 | | | |
| | | 00 | 01 | 11 | 10 |
| G3G2 | 00 | 0 | 0 | 0 | 0 |
| | 01 | 1 | 1 | 1 | 1 |
| | 11 | 0 | 0 | 0 | 0 |
| | 10 | 1 | 1 | 1 | 1 |

$$B2 = G3 \oplus G2$$

K-Map for B₁:

| | | | | | |
|------|----|------|----|----|----|
| | | G1G0 | | | |
| | | 00 | 01 | 11 | 10 |
| G3G2 | 00 | 0 | 0 | 1 | 1 |
| | 01 | 1 | 1 | 0 | 0 |
| | 11 | 0 | 0 | 1 | 1 |
| | 10 | 1 | 1 | 0 | 0 |

$$B1 = G3 \oplus G2 \oplus G1$$

| | |
|-----------------|--|
| Exp. No: | DESIGN AND IMPLEMENTATION OF CODE CONVERTER (BCD to excess-3 code converter &its vice versa) |
| Date: | |

AIM:

To design and implement 4-bit

- (i) BCD to excess-3 code converter
- (ii) Excess-3 to BCD code converter

APPARATUS REQUIRED:

| SL.NO. | COMPONENT | SPECIFICATION | QTY. |
|--------|----------------|---------------|------|
| 1. | X-OR GATE | IC 7486 | 1 |
| 2. | AND GATE | IC 7408 | 1 |
| 3. | OR GATE | IC 7432 | 1 |
| 4. | NOT GATE | IC 7404 | 1 |
| 5. | IC TRAINER KIT | - | 1 |
| 6. | PATCH CORDS | - | 35 |

THEORY:

The availability of large variety of codes for the same discrete elements of information results in the use of different codes by different systems. A conversion circuit must be inserted between the two systems if each uses different codes for same information. Thus, code converter is a circuit that makes the two systems compatible even though each uses different binary code.

The bit combination assigned to binary code to gray code. Since each code uses four bits to represent a decimal digit. There are four inputs and four outputs. Gray code is a non-weighted code.

The input variable are designated as B3, B2, B1, B0 and the output variables are designated as C3, C2, C1, Co. from the truth table, combinational circuit is designed. The Boolean functions are obtained from K-Map for each output variable.

A code converter is a circuit that makes the two systems compatible even though each uses a different binary code. To convert from binary code to Excess-3 code, the input lines must supply the bit combination of elements as specified by code and the output lines generate the corresponding bit combination of code. Each one of the four maps represents one of the four outputs of the circuit as a function of the four input variables

A two-level logic diagram may be obtained directly from the Boolean expressions derived by the maps. These are various other possibilities for a logic diagram that implements this circuit. Now the OR gate whose output is C+D has been used to implement partially each of three outputs.

TRUTH TABLE:

BCD TO EXCESS-3 CONVERTOR

| BCD input | | | | Excess – 3 output | | | |
|-----------|----|----|----|-------------------|----|----|----|
| B3 | B2 | B1 | B0 | G3 | G2 | G1 | G0 |
| 0 | 0 | 0 | 0 | 0 | 0 | 1 | 1 |
| 0 | 0 | 0 | 1 | 0 | 1 | 0 | 0 |
| 0 | 0 | 1 | 0 | 0 | 1 | 0 | 1 |
| 0 | 0 | 1 | 1 | 0 | 1 | 1 | 0 |
| 0 | 1 | 0 | 0 | 0 | 1 | 1 | 1 |
| 0 | 1 | 0 | 1 | 1 | 0 | 0 | 0 |
| 0 | 1 | 1 | 0 | 1 | 0 | 0 | 1 |
| 0 | 1 | 1 | 1 | 1 | 0 | 1 | 0 |
| 1 | 0 | 0 | 0 | 1 | 0 | 1 | 1 |
| 1 | 0 | 0 | 1 | 1 | 1 | 0 | 0 |
| 1 | 0 | 1 | 0 | x | x | x | x |
| 1 | 0 | 1 | 1 | x | x | x | x |
| 1 | 1 | 0 | 0 | x | x | x | x |
| 1 | 1 | 0 | 1 | x | x | x | x |
| 1 | 1 | 1 | 0 | x | x | x | x |
| 1 | 1 | 1 | 1 | x | x | x | x |

K-Map for E3:

| | | | | | |
|------|----|------|----|----|----|
| | | B1B0 | | | |
| | | 00 | 01 | 11 | 10 |
| B3B2 | 00 | 0 | 0 | 0 | 0 |
| | 01 | 0 | 1 | 1 | 1 |
| | 11 | x | x | x | x |
| | 10 | 1 | 1 | x | x |

$$E3 = B3 + B2 (B0 + B1)$$

K-Map for E2:

| | | | | | |
|------|----|------|----|----|----|
| | | B1B0 | | | |
| | | 00 | 01 | 11 | 10 |
| B3B2 | 00 | 0 | 1 | 1 | 1 |
| | 01 | 1 | | | |
| | 11 | x | x | x | x |
| | 10 | | 1 | x | x |

$$E2 = B2 \oplus (B1 + B0)$$

K-Map for E1:

| | | | | | |
|------|----|------|----|----|----|
| | | B1B0 | | | |
| | | 00 | 01 | 11 | 10 |
| B3B2 | 00 | 1 | 0 | 1 | 0 |
| | 01 | 1 | 0 | 1 | 0 |
| | 11 | x | x | x | x |
| | 10 | 1 | 0 | x | x |

$$E1 = B1 \oplus B0$$

K-Map for E0:

| | | | | | |
|------|----|------|----|----|----|
| | | B1B0 | | | |
| | | 00 | 01 | 11 | 10 |
| B3B2 | 00 | 1 | 0 | 0 | 1 |
| | 01 | 1 | 0 | 0 | 1 |
| | 11 | x | x | x | x |
| | 10 | 1 | 0 | x | x |

$$E0 = \overline{B0}$$

EXCESS-3 TO BCD CONVERTOR

TRUTH TABLE:

| Excess – 3 Input | | | | BCD Output | | | |
|------------------|----|----|----|------------|----|----|----|
| B3 | B2 | B1 | B0 | G3 | G2 | G1 | G0 |
| 0 | 0 | 1 | 1 | 0 | 0 | 0 | 0 |
| 0 | 1 | 0 | 0 | 0 | 0 | 0 | 1 |
| 0 | 1 | 0 | 1 | 0 | 0 | 1 | 0 |
| 0 | 1 | 1 | 0 | 0 | 0 | 1 | 1 |
| 0 | 1 | 1 | 1 | 0 | 1 | 0 | 0 |
| 1 | 0 | 0 | 0 | 0 | 1 | 0 | 1 |
| 1 | 0 | 0 | 1 | 0 | 1 | 1 | 0 |
| 1 | 0 | 1 | 0 | 0 | 1 | 1 | 1 |
| 1 | 0 | 1 | 1 | 1 | 0 | 0 | 0 |
| 1 | 1 | 0 | 0 | 1 | 0 | 0 | 1 |

LOGIC DIAGRAM:

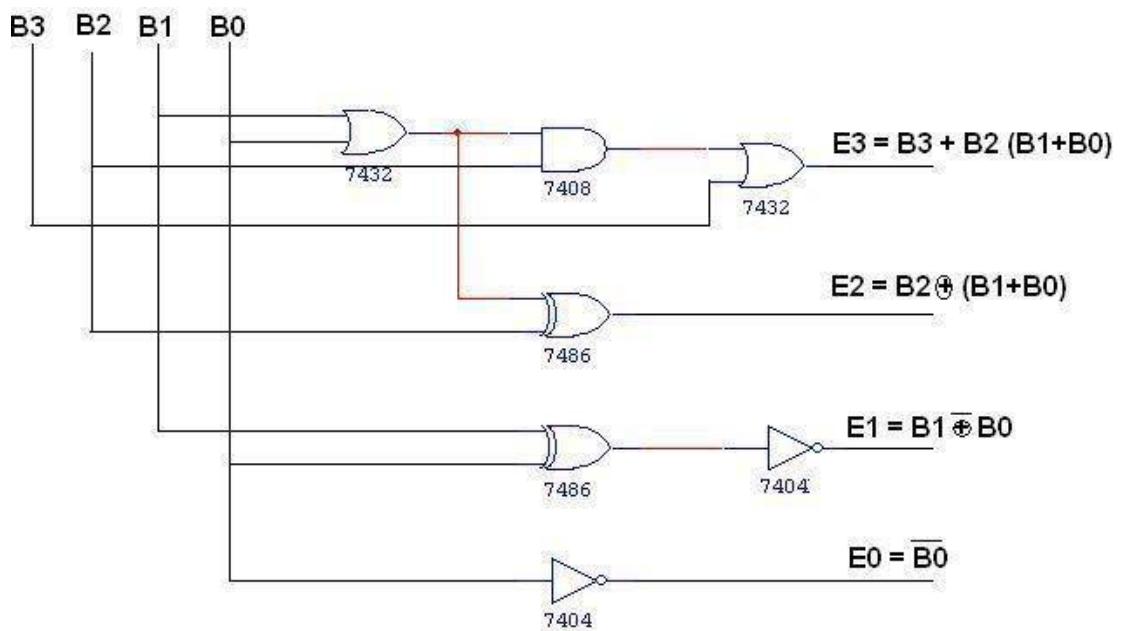

EXCESS-3 TO BCD CONVERTOR

K-Map for A:

| | | | | | |
|----|-----------|-----------|----|----|----|
| | | $X_3 X_4$ | | | |
| | $X_1 X_2$ | 00 | 01 | 11 | 10 |
| 00 | | X | X | 0 | X |
| 01 | | 0 | 0 | 0 | 0 |
| 11 | | 1 | X | X | X |
| 10 | | 0 | 0 | 1 | 0 |

$$A = X_1 X_2 + X_3 X_4 X_1$$

K-Map for B:

| | | | | | |
|----|-----------|-----------|----|----|----|
| | | $X_3 X_4$ | | | |
| | $X_1 X_2$ | 00 | 01 | 11 | 10 |
| 00 | | X | X | 0 | X |
| 01 | | 0 | 0 | 1 | 0 |
| 11 | | 0 | X | X | X |
| 10 | | 1 | 1 | 0 | 1 |

$$B = X_2 \oplus (\bar{X}_3 + \bar{X}_4)$$

K-Map for C:

| | | | | | |
|----|-----------|-----------|----|----|----|
| | | $X_3 X_4$ | | | |
| | $X_1 X_2$ | 00 | 01 | 11 | 10 |
| 00 | | X | X | 0 | X |
| 01 | | 0 | 1 | X | 1 |
| 11 | | 0 | X | X | X |
| 10 | | X | 1 | 0 | 1 |

$$C = X_3 \oplus X_4$$

K-Map for D:

| | | | | | |
|----|-------|-------|----|----|----|
| | | X3 X4 | | | |
| | | 00 | 01 | 11 | 10 |
| 00 | X1 X2 | X | X | 0 | X |
| 01 | | 1 | 0 | 0 | 1 |
| 11 | | 1 | X | X | X |
| 10 | | 1 | 0 | 0 | 1 |

$$D = \overline{X4}$$

EXCESS-3 TO BCD CONVERTOR

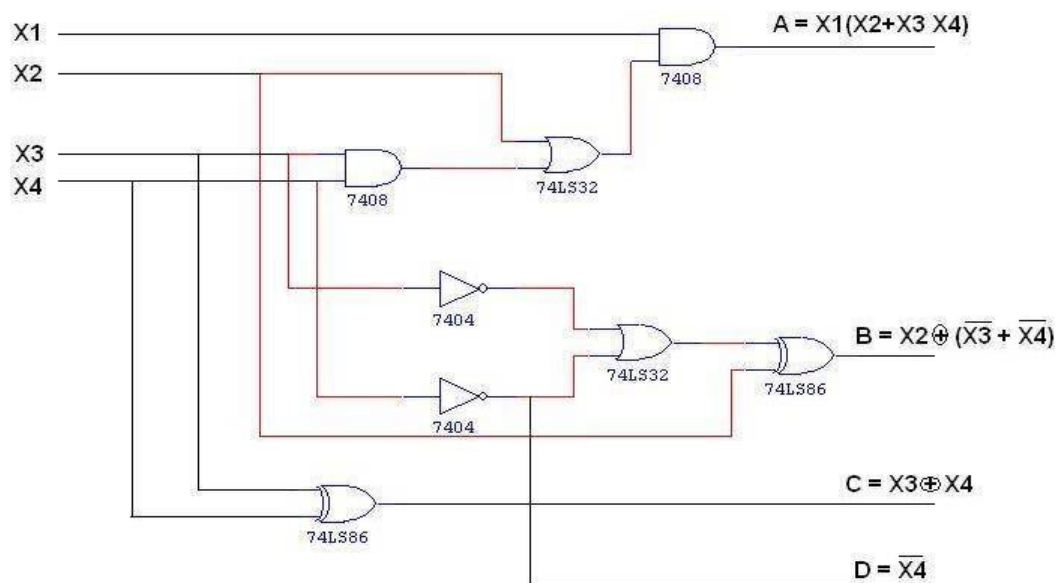

PROCEDURE:

- (i) Connections were given as per circuit diagram.
- (ii) Logical inputs were given as per truth table
- (iii) Observe the logical output and verify with the truth tables.

RESULT:

Thus the following 4-bit converters are designed and constructed.

- (i) BCD to excess-3 code converter
- (ii) Excess-3 to BCD code converter

Exp. No:

DESIGN OF ADDER AND SUBTRACTOR

Date:

AIM:

To design and construct half adder, full adder, half subtractor and full subtractor circuits and verify the truth table using logic gates.

APPARATUS REQUIRED:

| Sl.No. | COMPONENT | SPECIFICATION | QTY. |
|--------|----------------|---------------|------|
| 1. | AND GATE | IC 7408 | 1 |
| 2. | X-OR GATE | IC 7486 | 1 |
| 3. | NOT GATE | IC 7404 | 1 |
| 4. | OR GATE | IC 7432 | 1 |
| 3. | IC TRAINER KIT | - | 1 |
| 4. | PATCH CORDS | - | 23 |

THEORY:

HALF ADDER:

A half adder has two inputs for the two bits to be added and two outputs one from the sum 'S' and other from the carry 'c' into the higher adder position. Above circuit is called as a carry signal from the addition of the less significant bits sum from the X-OR Gate the carry out from the AND gate.

FULL ADDER:

A full adder is a combinational circuit that forms the arithmetic sum of input; it consists of three inputs and two outputs. A full adder is useful to add three bits at a time but a half adder cannot do so. In full adder sum output will be taken from X-OR Gate, carry output will be taken from OR Gate.

HALF SUBTRACTOR:

The half subtractor is constructed using X-OR and AND Gate. The half subtractor has two input and two outputs. The outputs are difference and borrow. The difference can be applied using X-OR Gate, borrow output can be implemented using an AND Gate and an inverter.

FULL SUBTRACTOR:

The full subtractor is a combination of X-OR, AND, OR, NOT Gates. In a full subtractor the logic circuit should have three inputs and two outputs. The two half subtractor put together gives a full subtractor. The first half subtractor will be C and A B. The output will be difference output of full subtractor. The expression AB assembles the borrow output of the half subtractor and the second term is the inverted difference output of first X-OR.

LOGIC DIAGRAM:

HALF ADDER

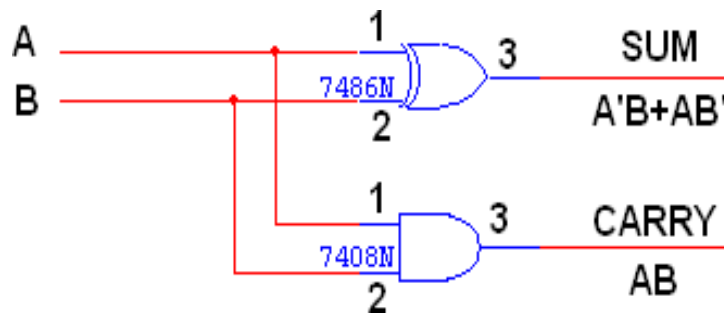

TRUTH TABLE:

| A | B | CARRY | SUM |
|---|---|-------|-----|
| 0 | 0 | 0 | 0 |
| 0 | 1 | 0 | 1 |
| 1 | 0 | 0 | 1 |
| 1 | 1 | 1 | 0 |

K-Map for SUM:

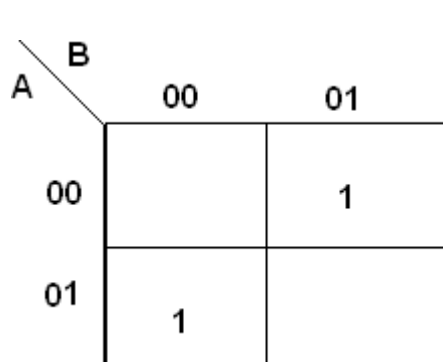

$$\text{SUM} = A'B + AB'$$

K-Map for CARRY:

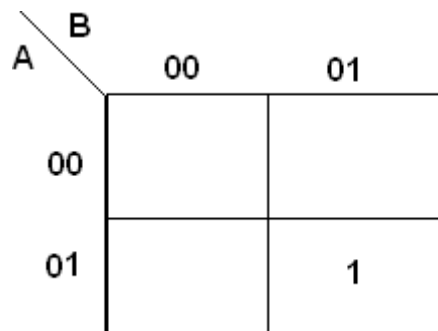

$$\text{CARRY} = AB$$

LOGIC DIAGRAM:

FULL ADDER

FULL ADDER USING TWO HALF ADDER

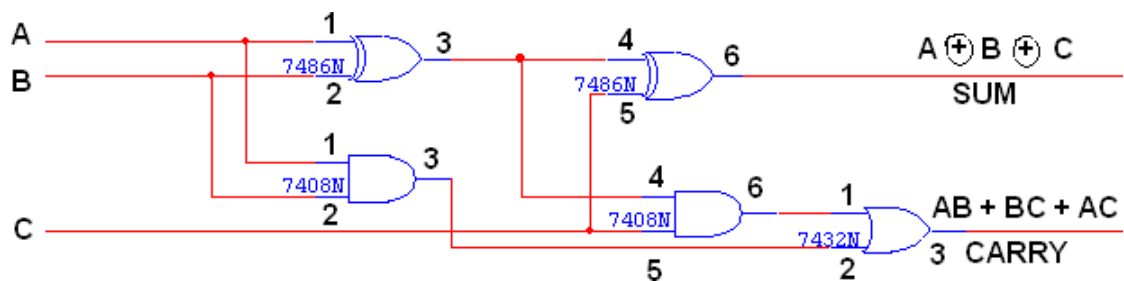

TRUTH TABLE:

| A | B | C | CARRY | SUM |
|---|---|---|-------|-----|
| 0 | 0 | 0 | 0 | 0 |
| 0 | 0 | 1 | 0 | 1 |
| 0 | 1 | 0 | 0 | 1 |
| 0 | 1 | 1 | 1 | 0 |
| 1 | 0 | 0 | 0 | 1 |
| 1 | 0 | 1 | 1 | 0 |
| 1 | 1 | 0 | 1 | 0 |
| 1 | 1 | 1 | 1 | 1 |

K-Map for SUM:

| | | | | | |
|---|---|----|----|----|----|
| | | BC | | | |
| | | 00 | 01 | 11 | 10 |
| A | 0 | | 1 | | 1 |
| | 1 | 1 | | 1 | |

$$\text{SUM} = A'B'C + A'BC' + ABC' + ABC$$

K-Map for CARRY:

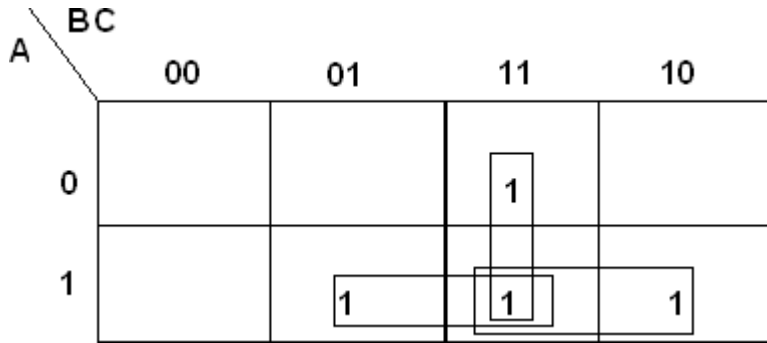

CARRY = AB + BC + AC

LOGIC DIAGRAM:

HALF SUBTRACTOR

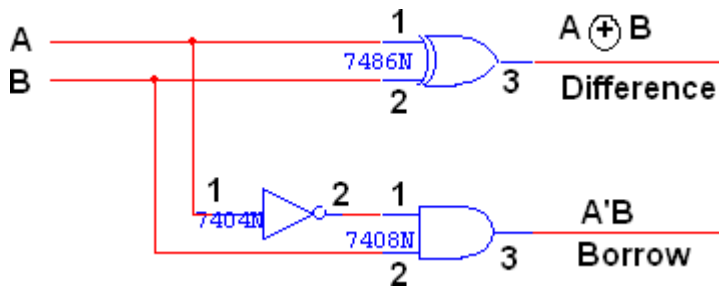

TRUTH TABLE:

| A | B | BORROW | DIFFERENCE |
|---|---|--------|------------|
| 0 | 0 | 0 | 0 |
| 0 | 1 | 1 | 1 |
| 1 | 0 | 0 | 1 |
| 1 | 1 | 0 | 0 |

K-Map for DIFFERENCE:

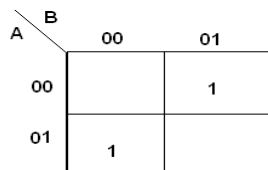

DIFFERENCE = A'B + AB'

K-Map for BORROW:

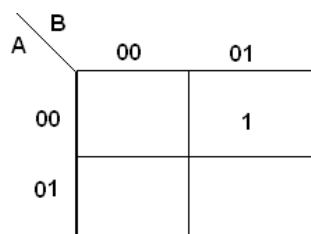

BORROW = A'B

**LOGIC DIAGRAM:
FULL SUBTRACTOR**

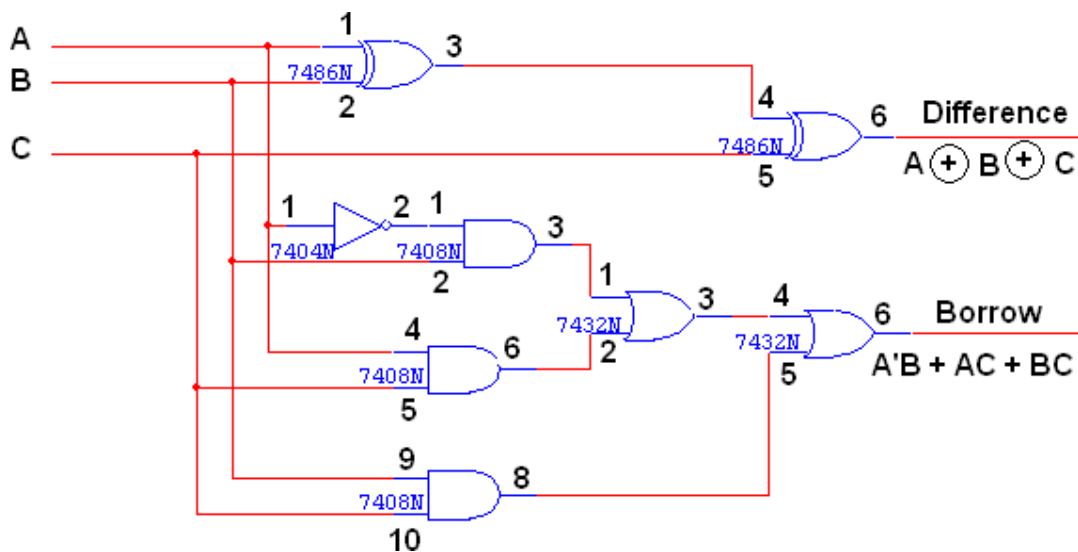

FULL SUBTRACTOR USING TWO HALF SUBTRACTOR :

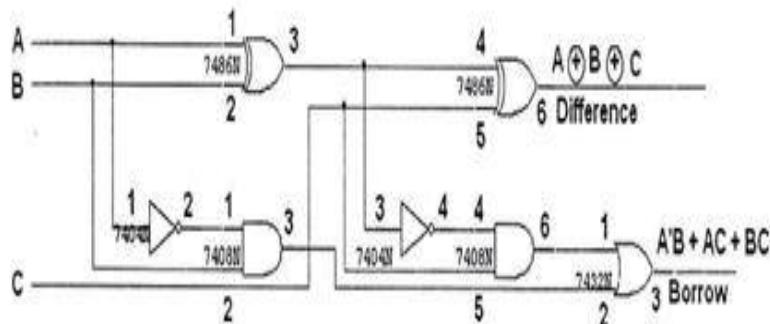

TRUTH TABLE:

| A | B | C | BORROW | DIFFERENCE |
|---|---|---|--------|------------|
| 0 | 0 | 0 | 0 | 0 |
| 0 | 0 | 1 | 1 | 1 |
| 0 | 1 | 0 | 1 | 1 |
| 0 | 1 | 1 | 1 | 0 |
| 1 | 0 | 0 | 0 | 1 |
| 1 | 0 | 1 | 0 | 0 |
| 1 | 1 | 0 | 0 | 0 |
| 1 | 1 | 1 | 1 | 1 |

K-Map for Difference:

| | | | | | |
|---|--|----|----|----|----|
| | | BC | | | |
| A | | 00 | 01 | 11 | 10 |
| 0 | | | 1 | | 1 |
| 1 | | 1 | | 1 | |

$$\text{Difference} = A'B'C + A'BC' + AB'C' + ABC$$

K-Map for Borrow:

| | | | | | |
|---|--|----|----|----|----|
| | | BC | | | |
| A | | 00 | 01 | 11 | 10 |
| 0 | | | 1 | 1 | 1 |
| 1 | | | | 1 | |

$$\text{Borrow} = A'B + BC + A'C$$

PROCEDURE:

- (i) Connections are given as per circuit diagram.
- (ii) Logical inputs are given as per circuit diagram.
- (iii) Observe the output and verify the truth table.

RESULT:

Thus half adder, full adder, half subtractor and full subtractor circuits are designed and constructed using logic gates and their truth table are verified.

| | |
|-----------------|--|
| Exp. No: | DESIGN OF ADDER AND SUBTRACTOR USING IC7483 |
| Date: | |

AIM:

To design and implement 4-bit adder and subtractor using basic gates and IC 7483.

APPARATUS REQUIRED:

| SL.NO. | COMPONENT | SPECIFICATION | QTY. |
|--------|----------------|---------------|------|
| 1. | IC | IC 7483 | 1 |
| 2. | EX-OR GATE | IC 7486 | 1 |
| 3. | NOT GATE | IC 7404 | 1 |
| 3. | IC TRAINER KIT | - | 1 |
| 4. | PATCH CORDS | - | 40 |

THEORY:

4 BIT BINARY ADDER:

A binary adder is a digital circuit that produces the arithmetic sum of two binary numbers. It can be constructed with full adders connected in cascade, with the output carry from each full adder connected to the input carry of next full adder in chain. The augends bits of 'A' and the addend bits of 'B' are designated by subscript numbers from right to left, with subscript 0 denoting the least significant bits. The carries are connected in chain through the full adder. The input carry to the adder is C_0 and it ripples through the full adder to the output carry C_4 .

4 BIT BINARY SUBTRACTOR:

The circuit for subtracting $A-B$ consists of an adder with inverters, placed between each data input 'B' and the corresponding input of full adder. The input carry C_0 must be equal to 1 when performing subtraction.

4 BIT BINARY ADDER/SUBTRACTOR:

The addition and subtraction operation can be combined into one circuit with one common binary adder. The mode input M controls the operation. When $M=0$, the circuit is adder circuit. When $M=1$, it becomes subtractor.

PIN DIAGRAM FOR IC 7483:

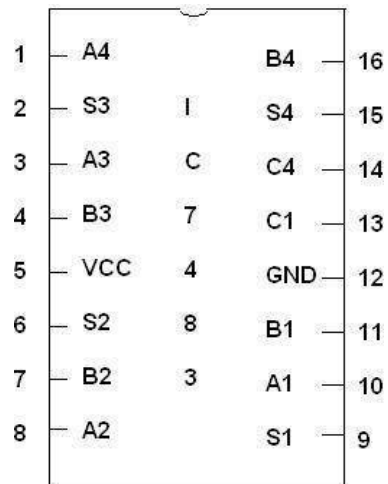

4-BIT BINARY ADDER

LOGIC DIAGRAM:

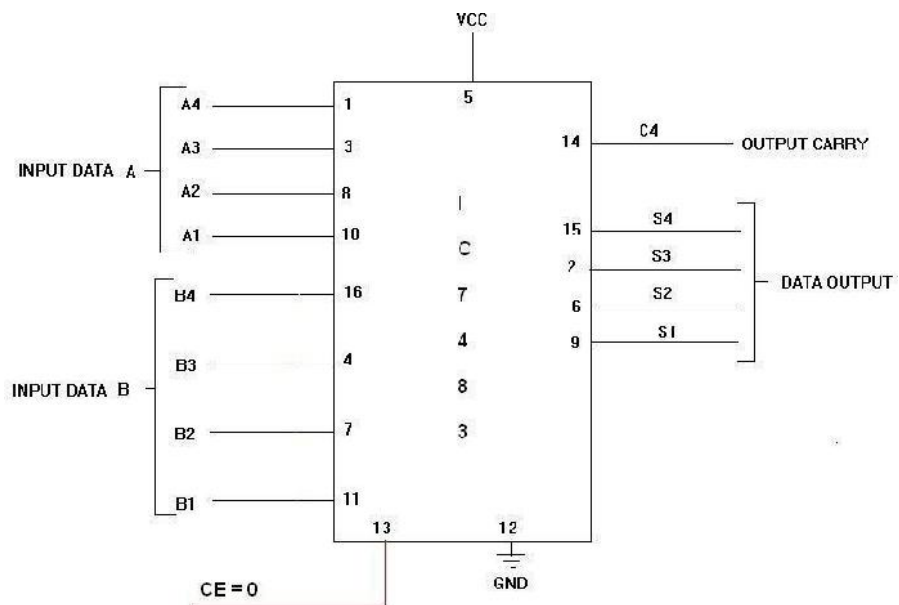

4-BIT BINARY SUBTRACTOR

LOGIC DIAGRAM:

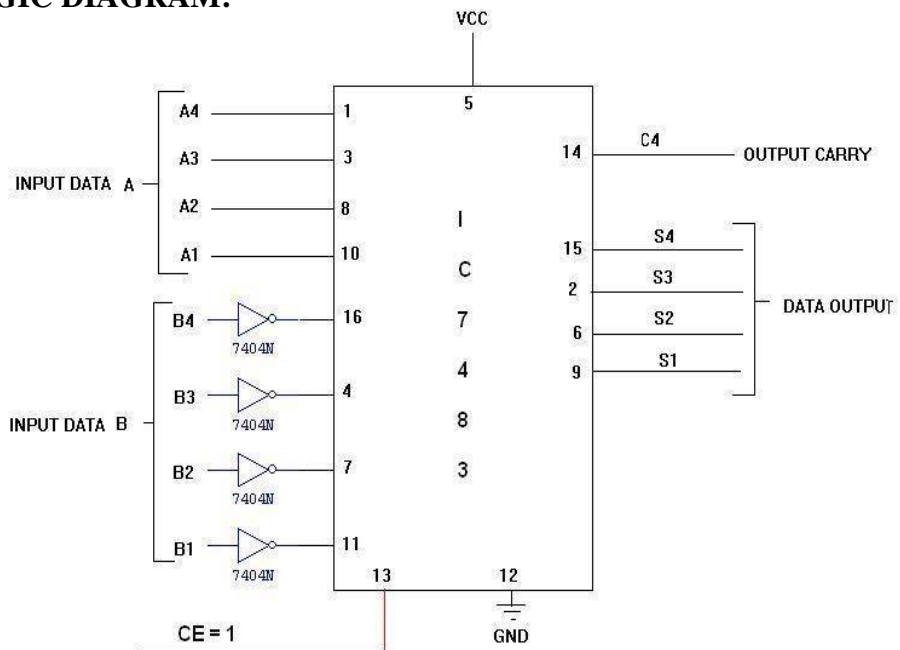

4-BIT BINARY ADDER/SUBTRACTOR

LOGIC DIAGRAM:

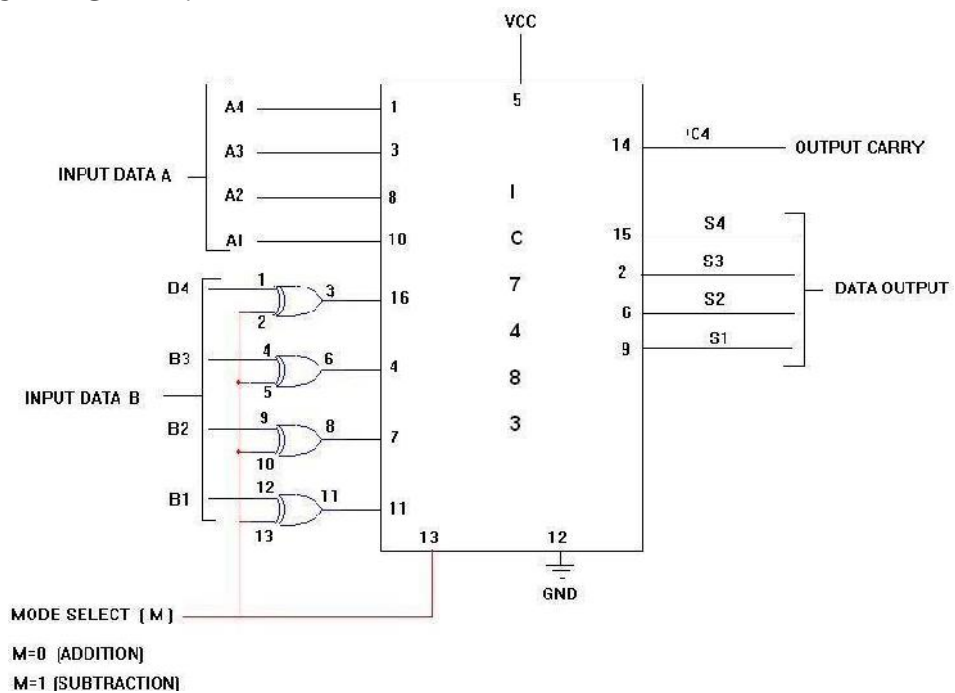

TRUTH TABLE :

| Input Data A | | | | Input Data B | | | | | Addition | | | | | | Subtraction | | | | |
|--------------|----|----|----|--------------|----|----|----|---|----------|----|----|----|---|----|-------------|----|----|--|--|
| A4 | A3 | A2 | A1 | B4 | B3 | B2 | B1 | C | S4 | S3 | S2 | S1 | B | D4 | D3 | D2 | D1 | | |
| 1 | 0 | 0 | 0 | 0 | 0 | 1 | 0 | 0 | 1 | 0 | 1 | 0 | 1 | 0 | 1 | 1 | 0 | | |
| 1 | 0 | 0 | 0 | 1 | 0 | 0 | 0 | 1 | 0 | 0 | 0 | 0 | 1 | 0 | 0 | 0 | 0 | | |
| 0 | 0 | 1 | 0 | 1 | 0 | 0 | 0 | 0 | 1 | 0 | 1 | 0 | 0 | 1 | 0 | 1 | 0 | | |
| 0 | 0 | 0 | 1 | 0 | 1 | 1 | 1 | 0 | 1 | 0 | 0 | 0 | 0 | 1 | 0 | 1 | 0 | | |
| 1 | 0 | 1 | 0 | 1 | 0 | 1 | 1 | 1 | 0 | 0 | 1 | 0 | 0 | 1 | 1 | 1 | 1 | | |
| 1 | 1 | 1 | 0 | 1 | 1 | 1 | 1 | 1 | 1 | 0 | 1 | 0 | 0 | 1 | 1 | 1 | 1 | | |
| 1 | 0 | 1 | 0 | 1 | 1 | 0 | 1 | 1 | 0 | 1 | 1 | 1 | 0 | 1 | 1 | 0 | 1 | | |

PROCEDURE:

- (i) Connections are given as per circuit diagram.
- (ii) Logical inputs are given as per circuit diagram.
- (iii) Observe the output and verify the truth table.

RESULT:

Thus the 4-bit adder and subtractor using basic gates and IC 7483 is designed and implemented.

| | | |
|----------|--|--|
| Exp. No. | | Design and implementation of 4 bit BCD adder using IC 7483. |
| Date | | |

AIM:

To design and implement 4-bit adder and subtractor using IC 7483.

APPARATUS REQUIRED:

| Sl.No. | COMPONENT | SPECIFICATION | QTY. |
|--------|----------------|---------------|------|
| 1. | IC | IC 7483 | 1 |
| 2. | EX-OR GATE | IC 7486 | 1 |
| 3. | NOT GATE | IC 7404 | 1 |
| 3. | IC TRAINER KIT | - | 1 |
| 4. | PATCH CORDS | - | 40 |

THEORY:

4 BIT BCD ADDER:

A binary adder is a digital circuit that produces the arithmetic sum of two binary numbers. It can be constructed with full adders connected in cascade, with the output carry from each full adder connected to the input carry of next full adder in chain. The augends bits of 'A' and the addend bits of 'B' are designated by subscript numbers from right to left, with subscript 0 denoting the least significant bits. The carries are connected in chain through the full adder. The input carry to the adder is C_0 and it ripples through the full adder to the output carry C_4 .

Consider the arithmetic addition of two decimal digits in BCD, together with an input carry from a previous stage. Since each input digit does not exceed 9, the output sum cannot be greater than 19, the 1 in the sum being an input carry. The output of two decimal digits must be represented in BCD and should appear in the form listed in the columns.

A BCD adder that adds 2 BCD digits and produce a sum digit in BCD. The 2 decimal digits, together with the input carry, are first added in the top 4 bit adder to produce the binary sum.

| | | | | | |
|-------|----|-------|----|----|----|
| | | S1 S2 | | | |
| | | 00 | 01 | 11 | 10 |
| S3 S4 | 00 | 0 | 0 | 0 | 0 |
| | 01 | 0 | 0 | 0 | 0 |
| | 11 | 1 | 1 | 1 | 1 |
| | 10 | 0 | 0 | 1 | 1 |

K MAP

$$Y = S4 (S3 + S2)$$

TRUTH TABLE:

| BCD SUM | | | | CARRY |
|---------|----|----|----|-------|
| S4 | S3 | S2 | S1 | C |
| 0 | 0 | 0 | 0 | 0 |
| 0 | 0 | 0 | 1 | 0 |
| 0 | 0 | 1 | 0 | 0 |
| 0 | 0 | 1 | 1 | 0 |
| 0 | 1 | 0 | 0 | 0 |
| 0 | 1 | 0 | 1 | 0 |
| 0 | 1 | 1 | 0 | 0 |
| 0 | 1 | 1 | 1 | 0 |
| 1 | 0 | 0 | 0 | 0 |
| 1 | 0 | 0 | 1 | 0 |
| 1 | 0 | 1 | 0 | 1 |
| 1 | 0 | 1 | 1 | 1 |
| 1 | 1 | 0 | 0 | 1 |
| 1 | 1 | 0 | 1 | 1 |
| 1 | 1 | 1 | 0 | 1 |
| 1 | 1 | 1 | 1 | 1 |

PROCEDURE:

- (i) Connections were given as per circuit diagram.
- (ii) Logical inputs were given as per truth table
- (iii) Observe the logical output and verify with the truth tables.

RESULT:

Thus the 4-bit BCD adder using IC 7483 is designed and implemented.

Exp. No:

Date:

**DESIGN AND IMPLEMENTATION OF
MULTIPLEXER AND DEMULTIPLEXER**

AIM:

To design and implement multiplexer and demultiplexer using logic gates and study of IC 74150 and IC 74154.

APPARATUS REQUIRED:

| Sl.No. | COMPONENT | SPECIFICATION | QTY. |
|--------|----------------|---------------|------|
| 1. | 3 I/P AND GATE | IC 7411 | 2 |
| 2. | OR GATE | IC 7432 | 1 |
| 3. | NOT GATE | IC 7404 | 1 |
| 2. | IC TRAINER KIT | - | 1 |
| 3. | PATCH CORDS | - | 32 |

THEORY:

MULTIPLEXER:

Multiplexer means transmitting a large number of information units over a smaller number of channels or lines. A digital multiplexer is a combinational circuit that selects binary information from one of many input lines and directs it to a single output line. The selection of a particular input line is controlled by a set of selection lines. Normally there are 2^n input line and n selection lines whose bit combination determine which input is selected.

DEMULTIPLEXER:

The function of Demultiplexer is in contrast to multiplexer function. It takes information from one line and distributes it to a given number of output lines. For this reason, the demultiplexer is also known as a data distributor. Decoder can also be used as demultiplexer.

In the 1: 4 demultiplexer circuit, the data input line goes to all of the AND gates. The data select lines enable only one gate at a time and the data on the data input line will pass through the selected gate to the associated data output line.

BLOCK DIAGRAM FOR 4:1 MULTIPLEXER:

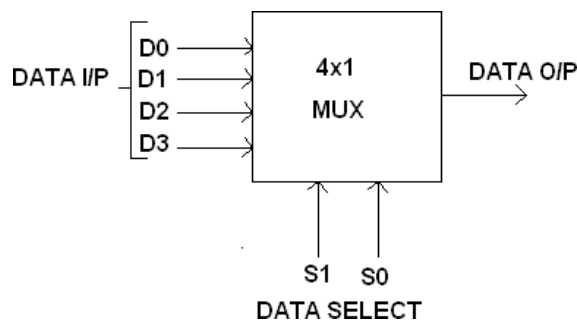

FUNCTION TABLE:

| S1 | S0 | INPUTS Y |
|----|----|-----------------------------|
| 0 | 0 | $D0 \rightarrow D0 S1' S0'$ |
| 0 | 1 | $D1 \rightarrow D1 S1' S0$ |
| 1 | 0 | $D2 \rightarrow D2 S1 S0'$ |
| 1 | 1 | $D3 \rightarrow D3 S1 S0$ |

$Y = D0 S1' S0' + D1 S1' S0 + D2 S1 S0' + D3 S1 S0$ CIRCUIT

DIAGRAM FOR MULTIPLEXER:

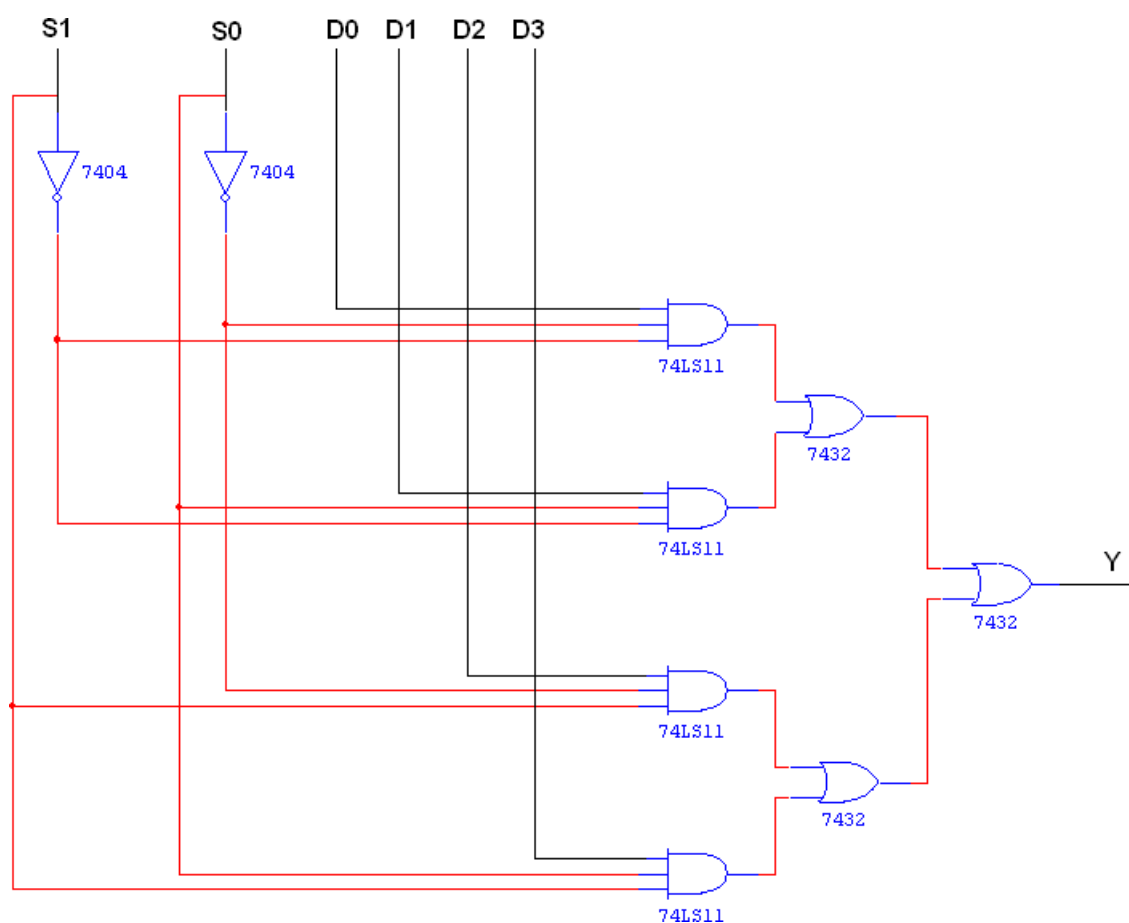

TRUTH TABLE:

| S1 | S0 | Y = OUTPUT |
|----|----|------------|
| 0 | 0 | D0 |
| 0 | 1 | D1 |
| 1 | 0 | D2 |
| 1 | 1 | D3 |

BLOCK DIAGRAM FOR 1:4 DEMULTIPLEXER:

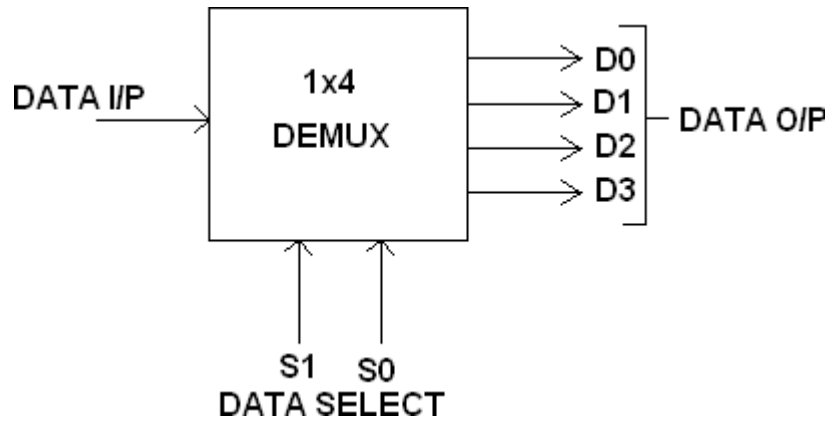

FUNCTION TABLE:

| S1 | S0 | INPUT |
|----|----|--------------------------------|
| 0 | 0 | $X \rightarrow D0 = X S1' S0'$ |
| 0 | 1 | $X \rightarrow D1 = X S1' S0$ |
| 1 | 0 | $X \rightarrow D2 = X S1 S0'$ |
| 1 | 1 | $X \rightarrow D3 = X S1 S0$ |

$$Y = X S1' S0' + X S1' S0 + X S1 S0' + X S1 S0$$

LOGIC DIAGRAM FOR DEMULTIPLEXER:

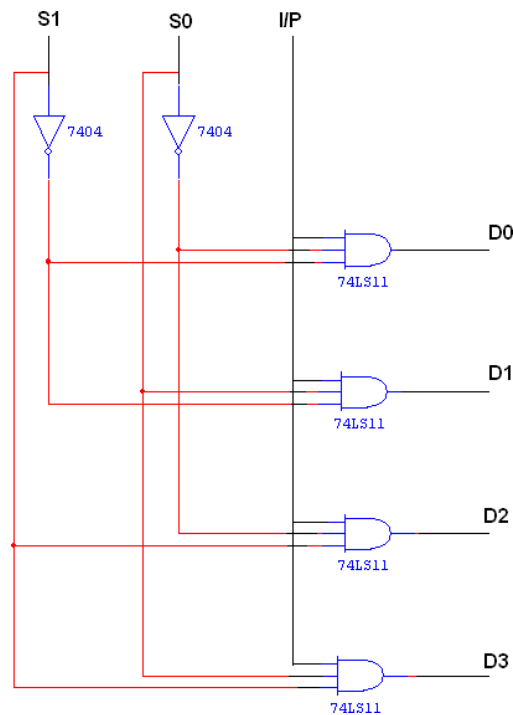

TRUTH TABLE:

| INPUT | | | OUTPUT | | | |
|-------|----|-----|--------|----|----|----|
| S1 | S0 | I/P | D0 | D1 | D2 | D3 |
| 0 | 0 | 0 | 0 | 0 | 0 | 0 |
| 0 | 0 | 1 | 1 | 0 | 0 | 0 |
| 0 | 1 | 0 | 0 | 0 | 0 | 0 |
| 0 | 1 | 1 | 0 | 1 | 0 | 0 |
| 1 | 0 | 0 | 0 | 0 | 0 | 0 |
| 1 | 0 | 1 | 0 | 0 | 1 | 0 |
| 1 | 1 | 0 | 0 | 0 | 0 | 0 |
| 1 | 1 | 1 | 0 | 0 | 0 | 1 |

PIN DIAGRAM FOR IC 74150:

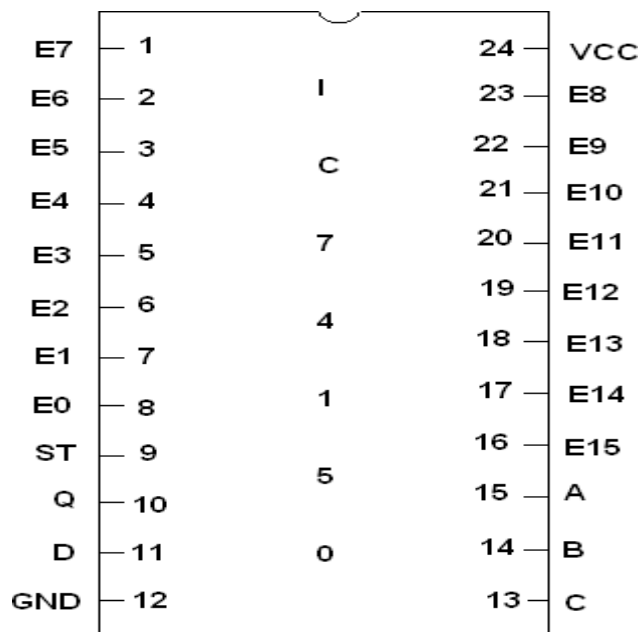

PIN DIAGRAM FOR IC 74154:

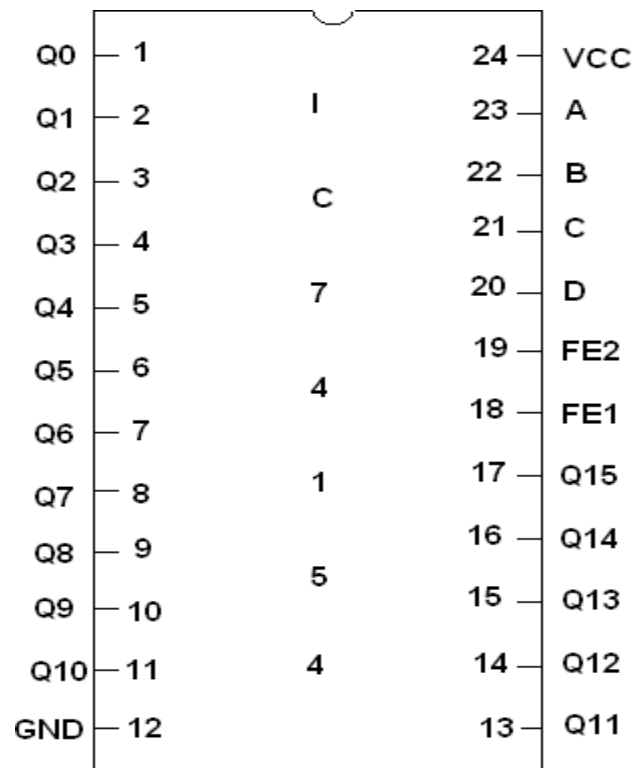

PROCEDURE:

- (i) Connections are given as per circuit diagram.
- (ii) Logical inputs are given as per circuit diagram.
- (iii) Observe the output and verify the truth table.

RESULT:

Thus the multiplexer and demultiplexer using logic gates are designed and implemented.

LOGIC DIAGRAM FOR ENCODER:

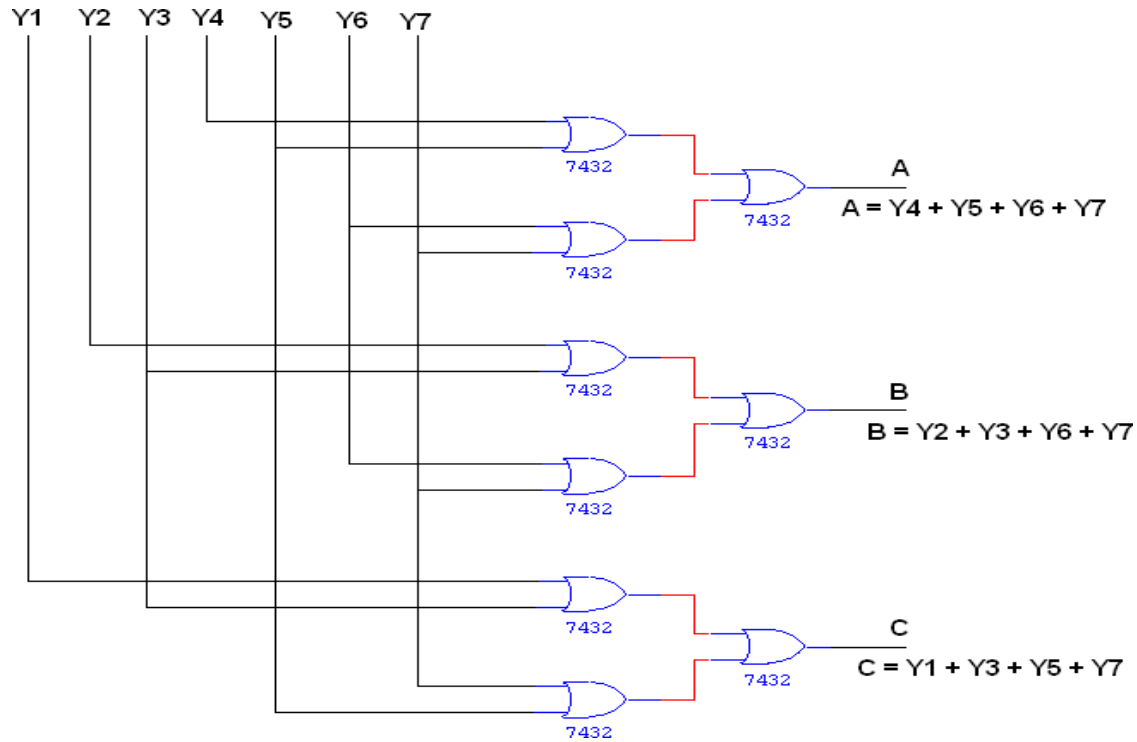

TRUTH TABLE:

| INPUT | | | | | | | OUTPUT | | |
|-------|----|----|----|----|----|----|--------|---|---|
| Y1 | Y2 | Y3 | Y4 | Y5 | Y6 | Y7 | A | B | C |
| 1 | 0 | 0 | 0 | 0 | 0 | 0 | 0 | 0 | 1 |
| 0 | 1 | 0 | 0 | 0 | 0 | 0 | 0 | 1 | 0 |
| 0 | 0 | 1 | 0 | 0 | 0 | 0 | 0 | 1 | 1 |
| 0 | 0 | 0 | 1 | 0 | 0 | 0 | 1 | 0 | 0 |
| 0 | 0 | 0 | 0 | 1 | 0 | 0 | 1 | 0 | 1 |
| 0 | 0 | 0 | 0 | 0 | 1 | 0 | 1 | 1 | 0 |
| 0 | 0 | 0 | 0 | 0 | 0 | 1 | 1 | 1 | 1 |

PIN DIAGRAM FOR IC 7445:

BCD TO DECIMAL DECODER:

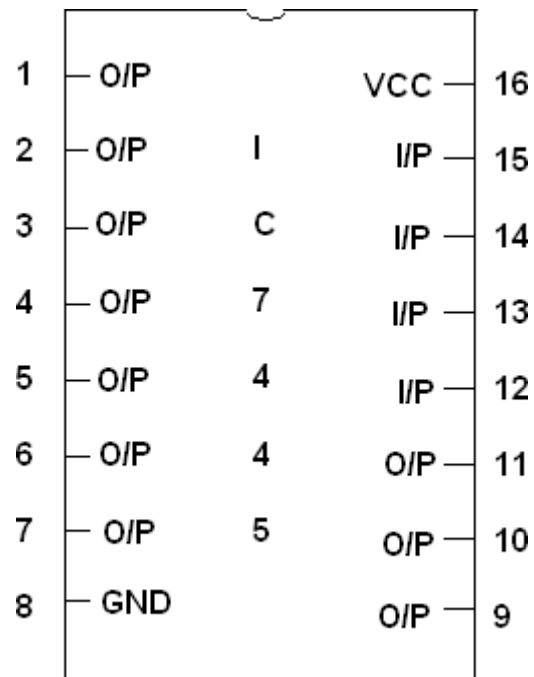

PIN DIAGRAM FOR IC 74147:

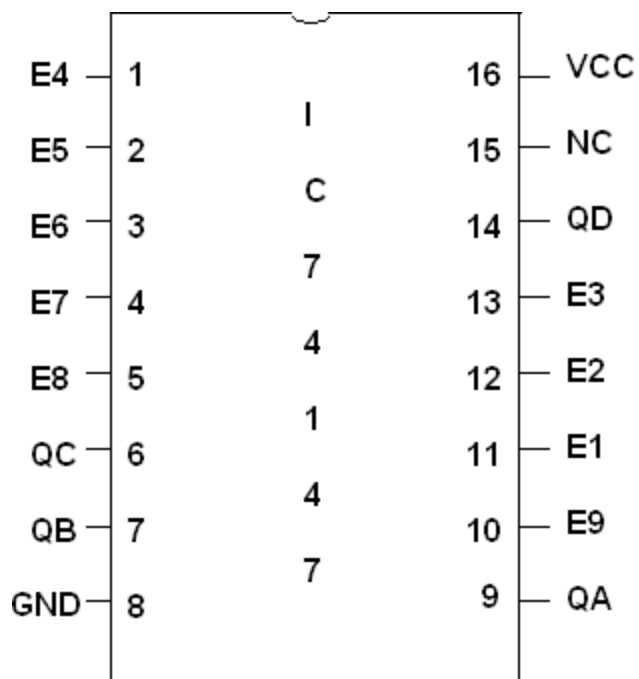

| | |
|-----------------|---|
| Exp. No: | DESIGN AND IMPLEMENTATION OF ENCODER AND DECODER |
| Date: | |

AIM:

To design and implement encoder and decoder using logic gates and study of IC 7445 and IC 74147.

APPARATUS REQUIRED:

| Sl.No. | COMPONENT | SPECIFICATION | QTY. |
|--------|-----------------|---------------|------|
| 1. | 3 I/P NAND GATE | IC 7410 | 2 |
| 2. | OR GATE | IC 7432 | 3 |
| 3. | NOT GATE | IC 7404 | 1 |
| 2. | IC TRAINER KIT | - | 1 |
| 3. | PATCH CORDS | - | 27 |

THEORY:

ENCODER:

An encoder is a digital circuit that perform inverse operation of a decoder. An encoder has 2^n input lines and n output lines. In encoder the output lines generates the binary code corresponding to the input value. In octal to binary encoder it has eight inputs, one for each octal digit and three output that generate the corresponding binary code. In encoder it is assumed that only one input has a value of one at any given time otherwise the circuit is meaningless. It has an ambiguala that when all inputs are zero the outputs are zero. The zero outputs can also be generated when $D_0 = 1$.

DECODER:

A decoder is a multiple input multiple output logic circuit which converts coded input into coded output where input and output codes are different. The input code generally has fewer bits than the output code. Each input code word produces a different output code word i.e there is one to one mapping can be expressed in truth table. In the block diagram of decoder circuit the encoded information is present as n input producing 2^n possible outputs. 2^n output values are from 0 through out $2^n - 1$.

LOGIC DIAGRAM FOR DECODER:

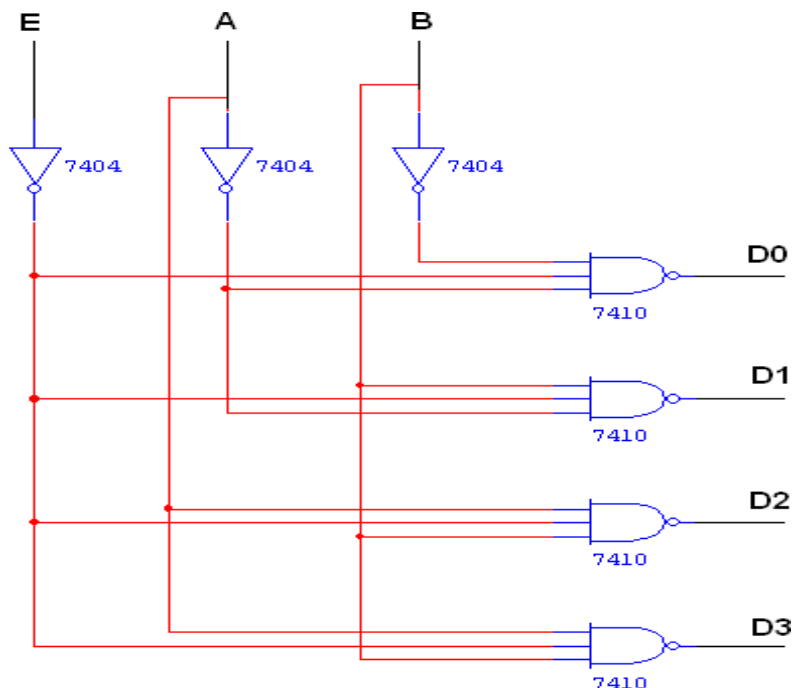

TRUTH TABLE:

| INPUT | | | OUTPUT | | | |
|-------|---|---|--------|----|----|----|
| E | A | B | D0 | D1 | D2 | D3 |
| 1 | 0 | 0 | 1 | 1 | 1 | 1 |
| 0 | 0 | 0 | 0 | 1 | 1 | 1 |
| 0 | 0 | 1 | 1 | 0 | 1 | 1 |
| 0 | 1 | 0 | 1 | 1 | 0 | 1 |
| 0 | 1 | 1 | 1 | 1 | 1 | 0 |

PROCEDURE:

- (i) Connections are given as per circuit diagram.
- (ii) Logical inputs are given as per circuit diagram.
- (iii) Observe the output and verify the truth table.

RESULT:

Thus the Encoder and decoder using logic gates are designed and implemented.

| | |
|-----------------|---|
| Exp. No: | DESIGN AND IMPLEMENTATION OF 3 BIT SYNCHRONOUS UP/DOWN COUNTER |
| Date: | |

AIM:

To design and implement 3 bit synchronous up/down counter.

APPARATUS REQUIRED:

| Sl.No. | COMPONENT | SPECIFICATION | QTY. |
|--------|----------------|---------------|------|
| 1. | JK FLIP FLOP | IC 7476 | 2 |
| 2. | 3 I/P AND GATE | IC 7411 | 1 |
| 3. | OR GATE | IC 7432 | 1 |
| 4. | XOR GATE | IC 7486 | 1 |
| 5. | NOT GATE | IC 7404 | 1 |
| 6. | IC TRAINER KIT | - | 1 |
| 7. | PATCH CORDS | - | 35 |

THEORY:

A counter is a register capable of counting number of clock pulse arriving at its clock input. Counter represents the number of clock pulses arrived. An up/down counter is one that is capable of progressing in increasing order or decreasing order through a certain sequence. An up/down counter is also called bidirectional counter. Usually up/down operation of the counter is controlled by up/down signal. When this signal is high counter goes through up sequence and when up/down signal is low counter follows reverse sequence.

K MAP

| | | | | |
|-------|-------|---|---|---|
| | QB QC | | | |
| UD QA | | | | |
| | 1 | 0 | 0 | 0 |
| | X | X | X | X |
| | X | X | X | X |
| | 0 | 0 | 1 | 0 |

$$JA = \bar{U}\bar{D}\bar{Q}B\bar{Q}C + UDQBQC$$

| | | | | |
|-------|-------|---|---|---|
| | QB QC | | | |
| UD QA | | | | |
| | X | X | X | X |
| | 1 | 0 | 0 | 0 |
| | 0 | 0 | 1 | 0 |
| | X | X | X | X |

$$KA = \bar{U}\bar{D}\bar{Q}B\bar{Q}C + UDQBQC$$

| | | | | |
|-------|-------|---|---|---|
| | QB QC | | | |
| UD QA | | | | |
| | 1 | X | X | 1 |
| | 1 | X | X | 1 |
| | 1 | X | X | 1 |
| | 1 | X | X | 1 |

$$JC = 1$$

| | | | | |
|-------|-------|---|---|---|
| | QB QC | | | |
| UD QA | | | | |
| | 1 | 0 | X | X |
| | 1 | 0 | X | X |
| | 0 | 1 | X | X |
| | 0 | 1 | X | X |

$$JB = UD \oplus QC$$

| | | | | |
|-------|-------|---|---|---|
| | QB QC | | | |
| UD QA | | | | |
| | X | X | 0 | 1 |
| | X | X | 0 | 1 |
| | X | X | 1 | 0 |
| | X | X | 1 | 0 |

$$KB = (UD \oplus QC)$$

| | | | | |
|-------|-------|---|---|---|
| | QB QC | | | |
| UD QA | | | | |
| | X | 1 | 1 | X |
| | X | 1 | 1 | X |
| | X | 1 | 1 | X |
| | X | 1 | 1 | X |

$$KC = 1$$

STATE DIAGRAM:

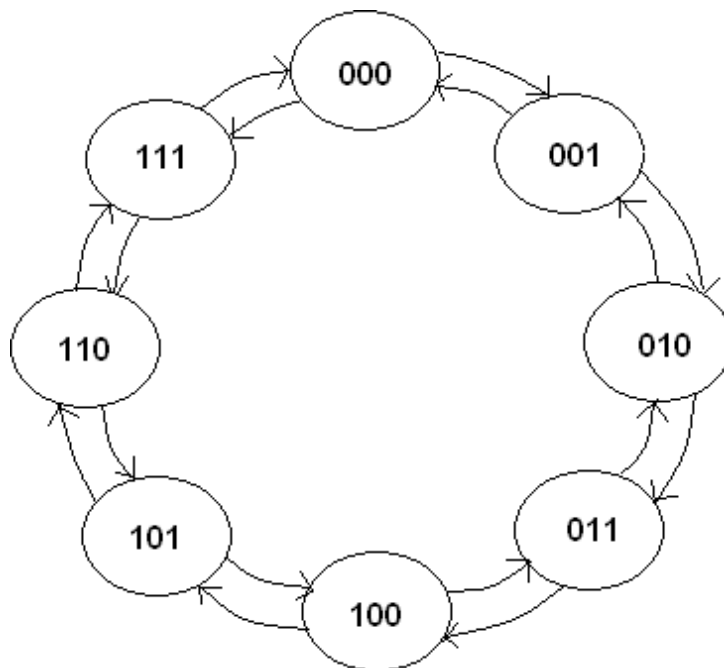

CHARACTERISTICS TABLE:

| Q | Q _{t+1} | J | K |
|---|------------------|---|---|
| 0 | 0 | 0 | X |
| 0 | 1 | 1 | X |
| 1 | 0 | X | 1 |
| 1 | 1 | X | 0 |

LOGIC DIAGRAM:

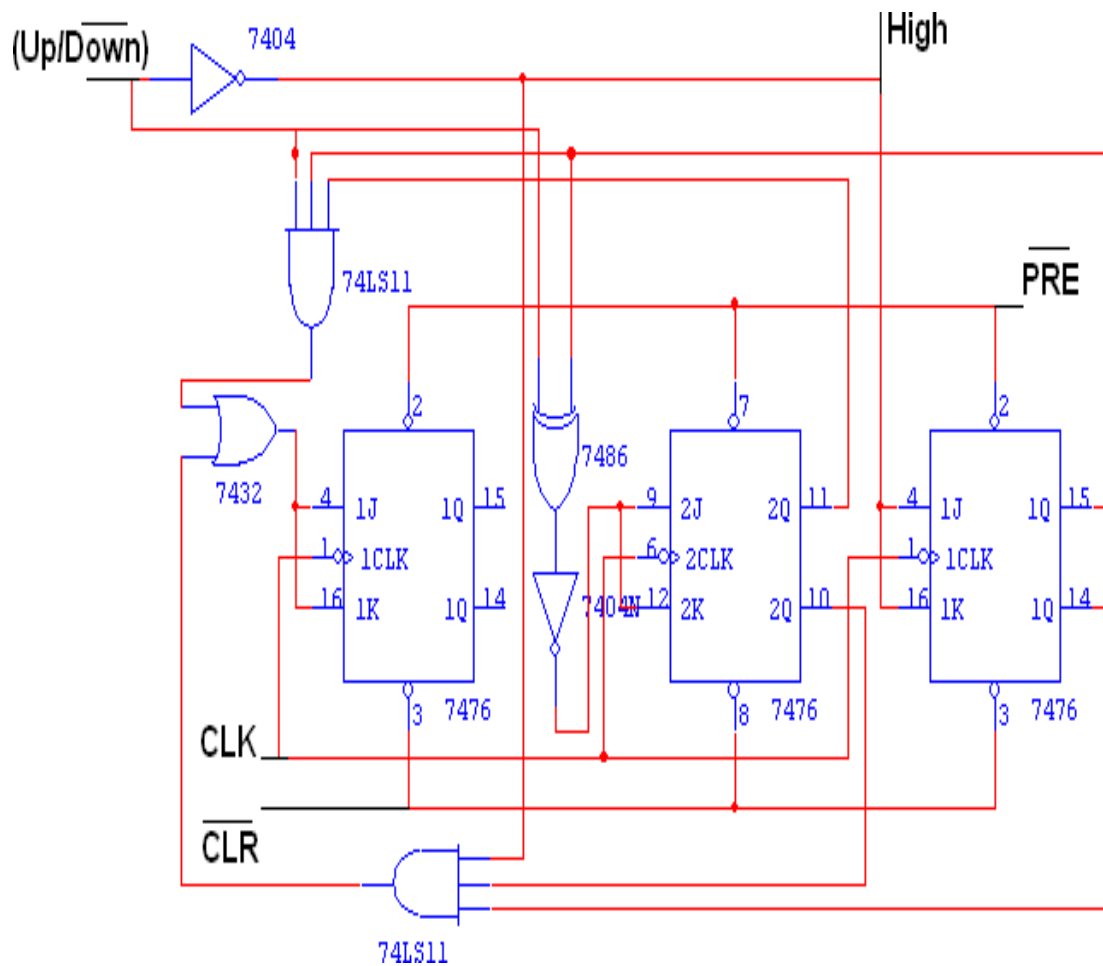

TRUTH TABLE:

| Input Up/Down | Present State | | | Next State Q_{A+1} | | | A | | B | | C | |
|------------------|---------------|-------|-------|----------------------|-----------|---|-------|-------|-------|-------|-------|-------|
| | Q_A | Q_B | Q_C | Q_{B+1} | Q_{C+1} | | J_A | K_A | J_B | K_B | J_C | K_C |
| 0 | 0 | 0 | 0 | 1 | 1 | 1 | 1 | X | 1 | X | 1 | X |
| 0 | 1 | 1 | 1 | 1 | 1 | 0 | X | 0 | X | 0 | X | 1 |
| 0 | 1 | 1 | 0 | 1 | 0 | 1 | X | 0 | X | 1 | 1 | X |
| 0 | 1 | 0 | 1 | 1 | 0 | 0 | X | 0 | 0 | X | X | 1 |
| 0 | 1 | 0 | 0 | 0 | 1 | 1 | X | 1 | 1 | X | 1 | X |
| 0 | 0 | 1 | 1 | 0 | 1 | 0 | 0 | X | X | 0 | X | 1 |
| 0 | 0 | 1 | 0 | 0 | 0 | 1 | 0 | X | X | 1 | 1 | X |
| 0 | 0 | 0 | 1 | 0 | 0 | 0 | 0 | X | 0 | X | X | 1 |
| 1 | 0 | 0 | 0 | 0 | 0 | 1 | 0 | X | 0 | X | 1 | X |
| 1 | 0 | 0 | 1 | 0 | 1 | 0 | 0 | X | 1 | X | X | 1 |
| 1 | 0 | 1 | 0 | 0 | 1 | 1 | 0 | X | X | 0 | 1 | X |
| 1 | 0 | 1 | 1 | 1 | 0 | 0 | 1 | X | X | 1 | X | 1 |
| 1 | 1 | 0 | 0 | 1 | 0 | 1 | X | 0 | 0 | X | 1 | X |
| 1 | 1 | 0 | 1 | 1 | 1 | 0 | X | 0 | 1 | X | X | 1 |
| 1 | 1 | 1 | 0 | 1 | 1 | 1 | X | 0 | X | 0 | 1 | X |
| 1 | 1 | 1 | 1 | 0 | 0 | 0 | X | 1 | X | 1 | X | 1 |

PROCEDURE:

- (i) Connections are given as per circuit diagram.
- (ii) Logical inputs are given as per circuit diagram.
- (iii) Observe the output and verify the truth table.

RESULT:

Thus the 3 bit synchronous up/down counter is designed and implemented

| | |
|-----------------|---|
| Exp. No: | DESIGN AND IMPLEMENTATION OF SHIFT REGISTERS |
| Date: | |

AIM:

To design and implement the following shift registers

- (i) Serial in serial out
- (ii) Serial in parallel out
- (iii) Parallel in serial out
- (iv) Parallel in parallel out

APPARATUS REQUIRED:

| SL.NO. | COMPONENT | SPECIFICATION | QTY. |
|--------|----------------|---------------|------|
| 1. | D FLIP FLOP | IC 7474 | 2 |
| 2. | OR GATE | IC 7432 | 1 |
| 3. | IC TRAINER KIT | - | 1 |
| 4. | PATCH CORDS | - | 35 |

THEORY:

A register is capable of shifting its binary information in one or both directions is known as shift register. The logical configuration of shift register consist of a D-Flip flop cascaded with output of one flip flop connected to input of next flip flop. All flip flops receive common clock pulses which causes the shift in the output of the flip flop. The simplest possible shift register is one that uses only flip flop. The output of a given flip flop is connected to the input of next flip flop of the register. Each clock pulse shifts the content of register one bit position to right.

PIN DIAGRAM OF IC 7474:

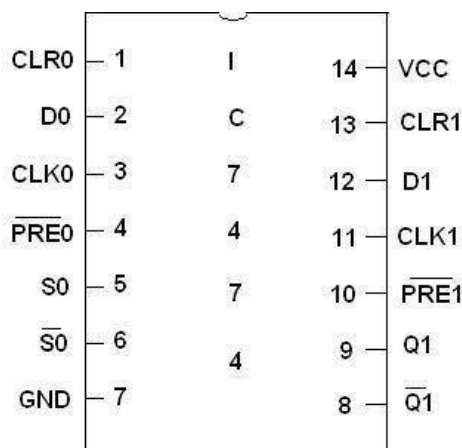

SERIAL IN SERIAL OUT

LOGIC DIAGRAM:

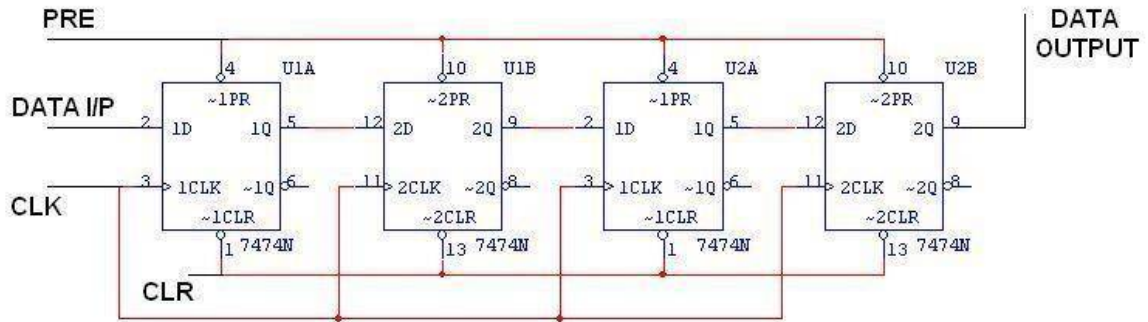

TRUTH TABLE:

| CLK | Serial In | Serial Out |
|-----|-----------|------------|
| 1 | 1 | 0 |
| 2 | 0 | 0 |
| 3 | 0 | 0 |
| 4 | 1 | 1 |
| 5 | X | 0 |
| 6 | X | 0 |
| 7 | X | 1 |

SERIAL IN PARALLEL OUT

LOGIC DIAGRAM:

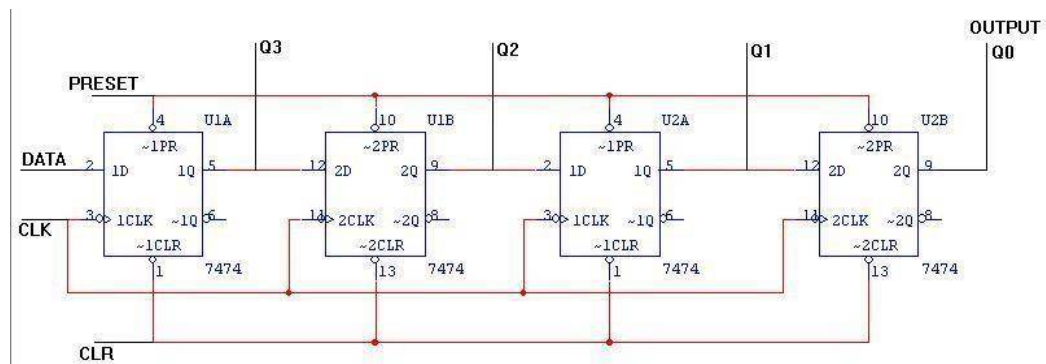

TRUTH TABLE:

| CLK | DATA | OUTPUT | | | |
|-----|------|----------------|----------------|----------------|----------------|
| | | Q _A | Q _B | Q _C | Q _D |
| 1 | 1 | 1 | 0 | 0 | 0 |
| 2 | 0 | 0 | 1 | 0 | 0 |
| 3 | 0 | 0 | 0 | 1 | 1 |
| 4 | 1 | 1 | 0 | 0 | 1 |

PARALLEL IN SERIAL OUT

LOGIC DIAGRAM:

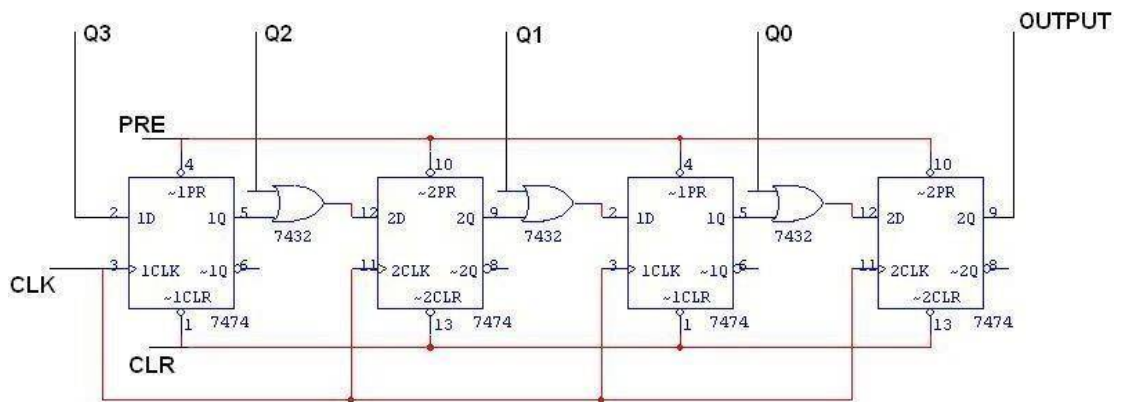

TRUTH TABLE:

| CLK | Q ₃ | Q ₂ | Q ₁ | Q ₀ | O/P |
|-----|----------------|----------------|----------------|----------------|-----|
| 0 | 1 | 0 | 0 | 1 | 1 |
| 1 | 0 | 0 | 0 | 0 | 0 |
| 2 | 0 | 0 | 0 | 0 | 0 |
| 3 | 0 | 0 | 0 | 0 | 1 |

PARALLEL IN PARALLEL OUT

LOGIC DIAGRAM:

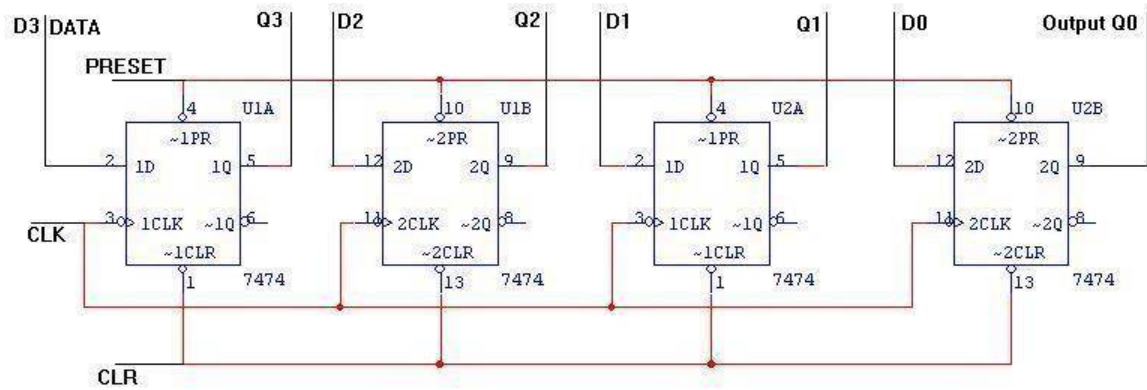

TRUTH TABLE:

| CLK | DATA INPUT | | | | OUTPUT | | | |
|-----|------------|----|----|----|--------|----|----|----|
| | DA | DB | DC | DD | QA | QB | QC | QD |
| 1 | 1 | 0 | 0 | 1 | 1 | 0 | 0 | 1 |
| 2 | 1 | 0 | 1 | 0 | 1 | 0 | 1 | 0 |

PROCEDURE:

- (i) Connections are given as per circuit diagram.
- (ii) Logical inputs are given as per circuit diagram.
- (iii) Observe the output and verify the truth table.

RESULT:

The Serial in serial out, Serial in parallel out, Parallel in serial out and Parallel in parallel out shift registers are designed and implemented.

| | |
|-----------------|---|
| Exp. No: | DESIGN OF 8 BIT MAGNITUDE COMPARATOR |
| Date: | |

AIM:

To design and implement the 8 bit magnitude comparator.

APPARATUS REQUIRED:

| SL.NO. | COMPONENT | SPECIFICATION | QTY. |
|--------|----------------------------|---------------|------|
| 1. | AND GATE | IC 7408 | 2 |
| 2. | X-OR GATE | IC 7486 | 1 |
| 3. | OR GATE | IC 7432 | 1 |
| 4. | NOT GATE | IC 7404 | 1 |
| 5. | 4-BIT MAGNITUDE COMPARATOR | IC 7485 | 2 |
| 6. | IC TRAINER KIT | - | 1 |
| 7. | PATCH CORDS | - | 30 |

THEORY:

The comparison of two numbers is an operator that determine one number is greater than, less than (or) equal to the other number. A magnitude comparator is a combinational circuit that compares two numbers A and B and determine their relative magnitude. The outcome of the comparator is specified by three binary variables that indicate whether $A > B$, $A = B$ (or) $A < B$.

$$A = A_3 A_2 A_1 A_0$$

$$B = B_3 B_2 B_1 B_0$$

The equality of the two numbers and B is displayed in a combinational circuit designated by the symbol $(A=B)$.

This indicates A greater than B, then inspect the relative magnitude of pairs of significant digits starting from most significant position. A is 0 and that of B is 0.

The same circuit can be used to compare the relative magnitude of two BCD digits. Where, $A = B$ is expanded as,

$$A = B = (A_3 + B_3) (A_2 + B_2) (A_1 + B_1) (A_0 + B_0)$$

⏏
⏏
⏏
⏏

X3
X2
X1
X0

PIN DIAGRAM FOR IC 7485:

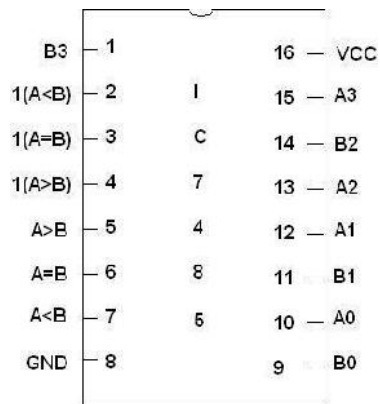

8-BIT MAGNITUDE COMPARATOR

LOGIC DIAGRAM:

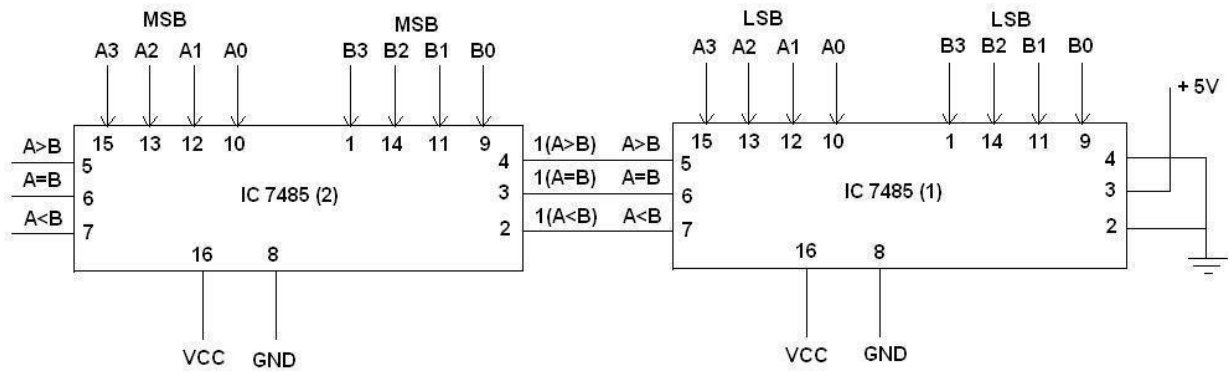

TRUTH TABLE:

| A | | B | | A>B | A=B | A<B |
|------|------|------|------|-----|-----|-----|
| 0000 | 0000 | 0000 | 0000 | 0 | 1 | 0 |
| 0001 | 0001 | 0000 | 0000 | 1 | 0 | 0 |
| 0000 | 0000 | 0001 | 0001 | 0 | 0 | 1 |

PROCEDURE:

- (i) Connections are given as per circuit diagram.
- (ii) Logical inputs are given as per circuit diagram.
- (iii) Observe the output and verify the truth table.

RESULT:

Thus the 8 bit magnitude comparator is designed and implemented.

| | | |
|----------|--|---|
| Exp. No. | | Design and implementation of 2 Bit Magnitude comparator using logic gates. |
| Date | | |

AIM:

To design and implement 2 – bit magnitude comparator using basic gates.

APPARATUS REQUIRED:

| Sl.No. | COMPONENT | SPECIFICATION | QTY. |
|--------|----------------------------|---------------|------|
| 1. | AND GATE | IC 7408 | 2 |
| 2. | X-OR GATE | IC 7486 | 1 |
| 3. | OR GATE | IC 7432 | 1 |
| 4. | NOT GATE | IC 7404 | 1 |
| 5. | 4-BIT MAGNITUDE COMPARATOR | IC 7485 | 2 |
| 6. | IC TRAINER KIT | - | 1 |
| 7. | PATCH CORDS | - | 30 |

THEORY:

The comparison of two numbers is an operator that determine one number is greater than, less than (or) equal to the other number. A magnitude comparator is a combinational circuit that compares two numbers.

A and B and determine their relative magnitude. The outcome of the comparator is specified by three binary variables that indicate whether $A > B$, $A = B$ (or) $A < B$.

$$A = A_3 A_2 A_1 A_0$$

$$B = B_3 B_2 B_1 B_0$$

The equality of the two numbers and B is displayed in a combinational circuit designated by the symbol $(A=B)$.

This indicates A greater than B, then inspect the relative magnitude of pairs of significant digits starting from most significant position. A is 0 and that of B is 0.

We have $A < B$, the sequential comparison can be expanded as

$$A > B = A_3 B_3^1 + X_3 A_2 B_2^1 + X_3 X_2 A_1 B_1^1 + X_3 X_2 X_1 A_0 B_0^1$$

$$A < B = A_3^1 B_3 + X_3 A_2^1 B_2 + X_3 X_2 A_1^1 B_1 + X_3 X_2 X_1 A_0^1 B_0$$

The same circuit can be used to compare the relative magnitude of two BCD digits.

Where, $A = B$ is expanded as,

$$A = B = (A_3 + B_3) (A_2 + B_2) (A_1 + B_1) (A_0 + B_0)$$

| | | | |
|-------|-------|-------|-------|
| ↓ | ↓ | ↓ | ↓ |
| x_3 | x_2 | x_1 | x_0 |

PROCEDURE:

- (i) Connections are given as per circuit diagram.
- (ii) Logical inputs are given as per circuit diagram.
- (iii) Observe the output and verify the truth table.

RESULT:

Thus the 2-bit magnitude comparator is designed and implemented.



EMBEDDED AND REAL TIME SYSTEMS

Edited by

BHARATHI.C



978-93-6255-425-3

EMBEDDED AND REAL TIME SYSTEMS Copyright @ 2023 by *Mrs. BHARATHI.C*

All rights reserved. No part of this book may be reproduced or transmitted in any form or by any means without written permission from the author.

ISBN: 978-93-6255-425-3

Publisher: PUBLICATIONS

TABLE OF CONTENTS

| CHAPTER | CONTENT | PAGE |
|----------------|--|-------------|
| | INTRODUCTION | 5 |
| 1 | BASICS OF REAL-TIME SYSTEMS A.AMUDHA | 13 |
| 2 | EMBEDDED SYSTEM ARCHITECTURE E. PRIYADHARSHINI | 28 |
| 3 | PROGRAMMING EMBEDDED SYSTEMS S.SARASWATHY | 49 |
| 4 | REAL-TIME OPERATING SYSTEMS (RTOS) R.SAVITHA | 64 |
| 5 | DESIGNING REAL-TIME SYSTEMS D.HARIKRISHNAN | 85 |
| | REFERENCES | 100 |

CHAPTER 1 BASICS OF REAL-TIME SYSTEMS

A.AMUDHA

*Assistant Professor, Department of ECE
Ponnaiyah Ramajayam Institute of Science and Technology, Tamil Nadu, India.*

Basics of Real-Time Systems

Real-Time Systems (RTS) are computing systems that must respond to inputs or events within a strict time frame. These systems are commonly used in scenarios where timing is critical, such as in embedded systems, industrial automation, medical devices, and avionics. The defining feature of a real-time system is not just correctness of the output, but the timeliness of the response.

1. Characteristics of Real-Time Systems

Time-Criticality

A real-time system must complete its tasks within predefined time constraints, often called deadlines.

Predictability

The behavior of real-time systems must be predictable. They are typically designed and tested to ensure that the system will meet its timing requirements in all expected conditions.

Concurrency

Real-time systems often handle multiple tasks or processes simultaneously. These concurrent tasks need to be scheduled and managed effectively to ensure timely execution.

Reliability

Real-time systems are often used in mission-critical applications where failures can result in significant consequences, such as safety hazards, financial loss, or damage to equipment.

Embedded Nature

Many real-time systems are embedded in larger mechanical or electrical systems, interacting directly with physical hardware (e.g., sensors, actuators, controllers). This integration with hardware requires efficient, real-time interaction with the external environment.

Types of Real-Time Systems

Real-time systems are broadly classified into two types based on the strictness of their timing constraints:

CHAPTER 2 EMBEDDED SYSTEM ARCHITECTURE

E. PRIYADHARSHINI

Assistant Professor, Department of ECE

Ponnaiyah Ramajayam Institute of Science and Technology, Tamil Nadu, India.

- Embedded System Architecture
- An Embedded System is a specialized computing system that is designed to perform dedicated tasks or functions within a larger mechanical or electrical system. Unlike general-purpose computers, embedded systems are typically designed for specific applications, where efficiency, low power consumption, and real-time operation are critical.
- The architecture of an embedded system is a combination of hardware and software components tailored for the intended application. The architecture must consider various factors such as performance, power efficiency, size, and cost.
- 1. Components of an Embedded System
- An embedded system typically consists of the following components:
 - 1.1 Hardware Components
 - The hardware of an embedded system is designed to meet the specific needs of the application and typically includes:
 - 1.1.1 Microcontroller (MCU) or Microprocessor (MPU)
 - Definition: The microcontroller or microprocessor is the "brain" of the embedded system. It executes the software and controls the system's overall functioning.
 - Microcontroller: Includes a CPU, memory, and peripheral interfaces on a single chip, ideal for simpler tasks (e.g., Arduino).
 - Microprocessor: A standalone CPU that requires external components like memory and peripherals, typically used in more complex systems (e.g., Raspberry Pi).
 - 1.1.2 Memory (RAM, ROM, Flash)
 - RAM (Random Access Memory): Temporary storage for data and program instructions currently being executed. It is volatile, meaning data is lost when power is turned off.
 - ROM (Read-Only Memory): Non-volatile memory that stores firmware or boot code that doesn't change frequently.
 - Flash Memory: Non-volatile memory used for storing program code, data, and updates. Often used for firmware storage.
 - 1.1.3 Input/Output (I/O) Interfaces
 - Definition: Embedded systems interact with the external world through input/output interfaces such as sensors, actuators, displays, and communication ports.
 - Examples: GPIO (General-Purpose Input/Output), ADC (Analog-to-Digital Converters), UART (Universal Asynchronous Receiver-Transmitter), I2C, SPI, etc.

CHAPTER 3 PROGRAMMING EMBEDDED SYSTEMS

S.SARASWATHY

Assistant Professor, Department of ECE

Ponnaiyah Ramajayam Institute of Science and Technology, Tamil Nadu, India.

Programming embedded systems involves writing software, known as firmware, that runs on embedded hardware to control specific functions. Embedded systems are usually resource-constrained, and they require efficient, real-time, and highly reliable code. Programming for embedded systems involves interacting closely with the hardware (sensors, actuators, communication interfaces), managing memory effectively, and often working under real-time constraints.

1. Programming Languages for Embedded Systems

Embedded system programming can be done using a variety of languages, depending on the system's complexity and resource constraints.

1.1 Assembly Language

Description: Assembly language is the most low-level programming language, allowing direct manipulation of hardware. It's often used for writing performance-critical sections of code.

1.2 C Description: C is the most popular language for embedded systems programming. It provides a good balance between low-level hardware control and high-level programming constructs..

1.3 C++

Description: C++ extends C by adding object-oriented programming (OOP) features. It is used in embedded systems where more complex software structures are required.

1.4 Python (MicroPython)

Description: Python, or its lightweight variant MicroPython, is sometimes used in higher-end embedded systems with more processing power and memory.

Advantages:

High-level, easy to learn and use.

Disadvantages:

Higher resource consumption compared to C or Assembly.

Use Case: Prototyping, IoT applications on microcontrollers like the ESP8266, and educational purposes.. 49

CHAPTER 4 REAL-TIME OPERATING SYSTEMS (RTOS)

R.SAVITHA

Assistant Professor, Department of ECE

Ponnaiyah Ramajayam Institute of Science and Technology, Tamil Nadu, India.

A Real-Time Operating System (RTOS) is a specialized operating system designed to manage hardware resources, run applications, and ensure that critical tasks are completed within specific time constraints. RTOS are commonly used in embedded systems where timing and reliability are paramount, such as automotive systems, medical devices, industrial automation, and telecommunications.

1. Key Characteristics of RTOS

1.1 Determinism

Definition: The ability to predict the maximum time a task will take to execute. An RTOS provides guaranteed response times for critical tasks.

Importance: Critical in applications where timely responses are necessary to avoid system failures or accidents.

1.2 Responsiveness

Definition: The RTOS must respond quickly to external events, often through interrupts.

Importance: The system's ability to react to stimuli within a specific time frame is crucial in applications like control systems.

1.3 Multi-threading

Definition: An RTOS can handle multiple tasks (threads) at the same time, enabling concurrent execution of applications.

Importance: Essential for managing different processes without interference, improving overall system efficiency.

1.4 Resource Management

Definition: Efficiently managing system resources (CPU, memory, I/O) to ensure that high-priority tasks receive the necessary resources.

Importance: Prevents resource starvation for critical tasks, ensuring system stability.

1.5 Inter-task Communication

Definition: Mechanisms (like semaphores, queues, and message passing) that allow tasks to communicate and synchronize with each other.
Importance: Facilitates cooperation between tasks in a multi-threaded environment

CHAPTER 5 DESIGNING REAL-TIME SYSTEMS

D.HARIKRISHNAN

Assistant Professor, Department of ECE

Ponnaiyah Ramajayam Institute of Science and Technology, Tamil Nadu, India.

Designing Real-Time Systems

Designing real-time systems involves creating applications that must respond to events or stimuli within strict timing constraints. These systems are prevalent in critical applications such as aerospace, automotive control systems, telecommunications, medical devices, and industrial automation. The design process requires careful consideration of timing, resource management, reliability, and safety.

1. Understanding Requirements

1.1 Functional Requirements

Define what the system should do, including specific tasks, inputs, outputs, and interactions with other systems.

1.2 Non-Functional Requirements

Timing Constraints: Specify deadlines for task execution (e.g., hard vs. soft deadlines).

Reliability: Define acceptable failure rates and recovery mechanisms.

Safety: Ensure the system operates without causing harm (e.g., in medical or automotive applications).

1.3 Performance Metrics

Determine key performance indicators such as response time, throughput, and resource utilization.

2. System Architecture

2.1 Modular Design

Break down the system into manageable components or modules, each responsible for specific tasks.

Benefits include improved maintainability, scalability, and testing.

SATELLITE COMMUNICATION

Edited by

DR.C.RAJINIKANTH



978-93-6255-250-1

SATELLITE COMMUNICATION

COPYRIGHT@2023BYDr.C.RAJINIKANTH

ALL RIGHTS RESERVED. NO PART OF THIS BOOK MAY BE REPRODUCED OR TRANSMITTED IN ANY FORM OR BY ANY MEANS WITHOUT WRITTEN PERMISSION FROM THE AUTHOR.

ISBN: 978-93-6255-250-1

PUBLISHER: Ponnaiyah Ramajayam Institute of Science and Technology (PRIST)

TABLE OF CONTENTS

| CHAPTER | CONTENT | PAGE |
|----------------|--|-------------|
| | INTRODUCTION | 5 |
| 1 | SATELLITE COMMUNICATION CONCEPTS | 13 |
| | Dr. SMITHA ELSA PETER | |
| 2 | SATELLITE ORBITS AND DYNAMICS | 30 |
| | Dr.S.AUDITHAN | |
| 3 | SATELLITE COMPONENTS AND ARCHITECTURE | 49 |
| | S.LILLYPET | |
| 4 | LINK BUDGET ANALYSIS | 64 |
| | S. MAHESWARAN | |
| 5 | MODULATION AND CODING TECHNIQUES | 85 |
| | T DIVYA MANOHARI | |
| | REFERENCES | 110 |

CHAPTER 1 SATELLITE COMMUNICATION CONCEPTS

Dr. SMITHA ELSA PETER

Professor, Department of ECE

Ponnaiyah Ramajayam Institute of Science and Technology, Tamil Nadu, India.

1. Definition: Satellite communication involves the transmission and reception of information via satellites orbiting Earth. This technology enables global and regional communication across vast distances, facilitating diverse applications from broadcasting to navigation.

2. Key Functions:

- **Transmission:** Data is sent from Earth to a satellite.
- **Reception:** Data is received from a satellite back to Earth.
- **Relay:** Satellites act as intermediaries, relaying signals between ground stations.

3. Types of Satellite Orbits:

- **Geostationary Orbit (GEO):**
 - **Altitude:** About 35,786 km above the equator.
 - **Characteristics:** Satellites appear stationary relative to a fixed point on Earth, ideal for continuous coverage.
 - **Applications:** Television broadcasting, weather monitoring, and communication.
- **Medium Earth Orbit (MEO):**
 - **Altitude:** Between 2,000 km and 35,786 km.
 - **Characteristics:** Satellites orbit more rapidly, offering broader coverage and higher revisit rates.
 - **Applications:** Navigation systems like GPS.
- **Low Earth Orbit (LEO):**
 - **Altitude:** Between 160 km and 2,000 km.
 - **Characteristics:** Shorter orbit period provides lower latency and higher-resolution observation.
 - **Applications:** Earth observation, remote sensing, and low-latency communication.

4. Satellite Components:

- **Space Segment:**
 - **Transponders:** Devices that receive, amplify, and retransmit signals.
 - **Antennas:** Used for sending and receiving signals.
 - **Power Systems:** Solar panels and batteries supply energy.
- **Ground Segment:**
 - **Ground Stations:** Facilities with large antennas and equipment for satellite interaction.
 - **Tracking Systems:** Monitor and control satellite position and health.
- **User Segment:**
 - **End-user Equipment:** Devices like satellite phones, TV receivers, and modems.

CHAPTER 2 SATELLITE ORBITS AND DYNAMICS

Dr.S.AUDITHAN

Associate Professor, Department of ECE

Ponnaiyah Ramajayam Institute of Science and Technology, Tamil Nadu, India.

1. Introduction to Satellite Orbits

- **Definition:** Satellite orbits are the paths that satellites follow as they circle Earth. The choice of orbit impacts the satellite's functionality, coverage area, and mission goals.

2. Types of Satellite Orbits

- **Geostationary Orbit (GEO):**
 - **Altitude:** Approximately 35,786 km above the equator.
 - **Characteristics:** Satellites in GEO appear stationary relative to a fixed point on Earth because their orbital period matches Earth's rotation.
 - **Applications:** Ideal for consistent coverage needed for communication, weather monitoring, and broadcasting.
- **Medium Earth Orbit (MEO):**
 - **Altitude:** Between 2,000 km and 35,786 km.
 - **Characteristics:** Satellites in MEO orbit Earth more rapidly than those in GEO, allowing for broader coverage and more frequent revisits.
 - **Applications:** Used for navigation systems like GPS and certain communication and scientific missions.
- **Low Earth Orbit (LEO):**
 - **Altitude:** Between 160 km and 2,000 km.
 - **Characteristics:** Satellites in LEO complete an orbit in about 90 to 120 minutes, providing low latency and high-resolution imaging.
 - **Applications:** Suitable for Earth observation, remote sensing, and communications requiring low latency.

3. Orbital Mechanics

- **Kepler's Laws:**
 - **First Law:** Satellites orbit Earth in elliptical paths with Earth at one focus.
 - **Second Law:** The line connecting the satellite to Earth sweeps out equal areas in equal times, indicating varying speed along the orbit.
 - **Third Law:** The square of a satellite's orbital period is proportional to the cube of its orbit's semi-major axis.
- **Orbital Elements:**
 - **Semi-Major Axis (a):** The average distance from the satellite to Earth.
 - **Eccentricity (e):** The degree of deviation of the orbit from a perfect circle.
 - **Longitude of Ascending Node (Ω):** The angle between the vernal equinox and the ascending node.

CHAPTER 3 SATELLITE COMPONENTS AND ARCHITECTURE

S.LILLYPET

*Associate Professor, Department of ECE
Ponnaiyah Ramajayam Institute of Science and Technology, Tamil Nadu, India.*

1. Space Segment

- **Transponders:**
 - **Function:** Receive, amplify, and retransmit signals between Earth and the satellite.
 - **Components:** Include a receiver, amplifier, and transmitter. Designed for specific frequency bands such as C-band, Ku-band, or Ka-band.
- **Antennas:**
 - **Receiving Antennas:** Capture signals from Earth, typically high gain with narrow beamwidth.
 - **Transmitting Antennas:** Send signals to Earth, focusing energy in specific directions.

2. Ground Segment

- **Ground Stations:**
 - **Function:** Facilitate communication between satellites and Earth.
 - **Components:** Large parabolic dish antennas, receivers, transmitters, and control systems.
- **Tracking Systems:**
 - **Function:** Monitor the satellite's position to ensure accurate data transmission.
 - **Components:** Radar and optical tracking systems.
- **Control Centers:**
 - **Function:** Manage satellite operations including scheduling, command, control, and troubleshooting.
 - **Components:** Workstations, software tools, and communication links to the satellite.

3. Satellite Architecture

- **System Architecture:**
 - **Design:** Integrates space, ground, and user segments for seamless operation.
 - **Considerations:** Coverage area, bandwidth, power requirements, and reliability.
- **Redundancy and Reliability:**
 - **Function:** Ensures continuous operation despite component failures.
 - **Components:** Includes redundant systems and failover mechanisms.
- **Mission Design:**
 - **Function:** Tailors architecture to meet specific mission objectives such as Earth observation, communication, or navigation.

CHAPTER 4 LINK BUDGET ANALYSIS

S.MAHESWARAN

*Assistant Professor, Department of ECE
Ponnaiyah Ramajayam Institute of Science and Technology, Tamil Nadu, India.*

Link budget analysis is vital in satellite communication for evaluating the performance of a communication link by calculating the total gain and loss in signal strength from the transmitter to the receiver. This ensures that the received signal is strong enough to be accurately decoded.

1. Basic Concept

The link budget represents the signal power loss or gain across the communication link. It factors in all gains and losses from the transmitter to the receiver.

2. Key Parameters

- **Transmitter Power (P_T):** The power output from the satellite or ground station's transmitter, typically measured in dBm (decibels relative to 1 milliwatt).
- **Antenna Gain (G_T):** The increase in signal strength due to the transmitting antenna, measured in dBi (decibels relative to an isotropic radiator).
- **Free-Space Path Loss (L_{FS}):** The loss of signal strength as it travels through space, calculated using the formula:

3. Link Budget Calculation

The basic link budget formula is:

$$P_R = P_T + G_T + G_R - L_{FS} - N$$

where:

- P_R = Received Signal Power
- P_T = Transmitter Power
- G_T = Transmitter Antenna Gain
- G_R = Receiver Antenna Gain
- L_{FS} = Free-Space Path Loss
- N = System Noise

4. Link Margin Analysis

The link margin is calculated as:

$$\text{Link Margin} = P_R - P_{R,\min}$$

CHAPTER 5 MODULATION AND CODING TECHNIQUES

T. DIVYA MANOHARI

Assistant Professor, Department of ECE

Ponnaiyah Ramajayam Institute of Science and Technology, Tamil Nadu, India.

Modulation and coding are essential for efficient and reliable satellite communication. These techniques ensure that data is properly adapted for transmission and that errors occurring during transmission are corrected. Here's a concise overview:

1. Modulation Techniques

Modulation adjusts a carrier signal's characteristics (amplitude, frequency, or phase) to encode information. Key techniques include:

- **Analog Modulation:**
 - **Amplitude Modulation (AM):** Varies the carrier wave's amplitude. While used in traditional broadcasting, it's less common in satellite systems due to noise susceptibility.
 - **Frequency Modulation (FM):** Alters the carrier wave's frequency, offering better noise resistance and occasional use in satellite communications.
- **Digital Modulation:**
 - **Phase Shift Keying (PSK):** Encodes data by varying the phase of the carrier. Variants include Binary PSK (BPSK) and Quadrature PSK (QPSK).
 - **Quadrature Amplitude Modulation (QAM):** Combines amplitude and phase modulation to transmit multiple bits per symbol, with higher-order QAM (e.g., 16-QAM, 64-QAM) supporting higher data rates.
 - **Frequency Shift Keying (FSK):** Changes the carrier frequency to encode data, useful for simpler systems or as a backup method.

2. Coding Techniques

Coding enhances data integrity and corrects transmission errors. Key methods include:

- **Error Detection Codes:**
 - **Parity Bits:** Simple method adding a bit for even or odd parity to detect single-bit errors.
 - **Checksums:** Summarize data values to identify errors, more complex than parity.
- **Error Correction Codes:**
 - **Forward Error Correction (FEC):** Adds redundant data to enable error correction without retransmission. Common FEC codes include:
 - **Hamming Codes:** Provide single-error correction and double-error detection.
 - **Reed-Solomon Codes:** Correct multiple errors and erasures, suitable for data storage and satellite communication.
 - **Convolutional Codes:** Encode data using a sliding window approach, often paired with Viterbi decoding for error correction.

DIGITAL SIGNAL PROCESSING

Edited by

DR.C.RAJINIKANTH



978-93-6255-655-4

DIGITAL SIGNAL PROCESSING

COPYRIGHT@2023BYDr.C.RAJINIKANTH

ALL RIGHTS RESERVED. NO PART OF THIS BOOK MAY BE REPRODUCED OR TRANSMITTED IN ANY FORM OR BY ANY MEANS WITHOUT WRITTEN PERMISSION FROM THE AUTHOR.

ISBN: 978-93-6255-655-4

PUBLISHER: Ponnaiyah Ramajayam Institute of Science and Technology (PRIST)

TABLE OF CONTENTS

| CHAPTER | CONTENT | PAGE |
|----------------|--|-------------|
| | INTRODUCTION | 5 |
| 1 | DISCRETE-TIME SIGNALS AND SYSTEMS | 13 |
| | R.SAVITHA | |
| 2 | DIGITAL FILTER DESIGN | 30 |
| | A.AMUDHA | |
| 3 | APPLICATIONS OF DIGITAL FILTERS | 49 |
| | S.SARASWATHY | |
| 4 | SAMPLING AND QUANTIZATION | 64 |
| | P.GEETHA | |
| 5 | APPLICATIONS OF DSP | 85 |
| | S. MAHESWARAN | |
| | REFERENCES | 110 |

CHAPTER 1 DISCRETE-TIME SIGNALS AND SYSTEMS

R.SAVITHA

Assistant Professor, Department of ECE

Ponnaiyah Ramajayam Institute of Science and Technology, Tamil Nadu, India.

Discrete-time signals and systems are fundamental concepts in the field of digital signal processing (DSP), which deals with signals that are represented as sequences of values at discrete time intervals. Understanding discrete-time signals and systems is crucial for digital communications, control systems, image processing, and various other fields where digital technology is applied.

Here's an overview of discrete-time signals and systems:

1. Discrete-Time Signals

A discrete-time signal is a sequence of values (or samples) taken at discrete time intervals. Unlike continuous signals, which vary over time without interruption, discrete-time signals are defined only at specific instances in time.

Graphical Representation: Discrete-time signals are plotted as sequences of points (samples) on a graph, where the horizontal axis represents time (discrete indices) and the vertical axis represents the amplitude.

1.2 Types of Discrete-Time Signals

Deterministic vs. Random:

Deterministic: The value of the signal is exactly known and can be described mathematically.

Random (or Stochastic): The signal's value cannot be exactly predicted and is described statistically.

Periodic vs. Aperiodic:

Periodic: A signal is periodic if it repeats after a certain interval

Aperiodic: The signal does not repeat itself.

Energy vs. Power Signals:

Energy Signal: If the total energy of the signal is finite.

Power Signal: If the average power of the signal is finite over an infinite time period.

Discrete-Time Systems

A discrete-time system processes or manipulates discrete-time signals. A system takes an input signal, processes it, and produces an output signal.

2.1 System Classification

Linear vs. Nonlinear Systems

Discrete-Time System Analysis

3.1 Difference Equations

Difference equations describe the relationship between the input and output of a discrete-time system.

3.2 Z-Transform

The Z-transform is a powerful tool used to analyze discrete-time signals and systems. It converts a discrete-time signal from the time domain to the Z-domain, simplifying the analysis of LTI systems.

Z-Transform Definition:

$$X(z) = \sum_{n=-\infty}^{\infty} x[n]z^{-n} \quad X(z) = \sum_{n=-\infty}^{\infty} x[n]z^{-n}$$

Region of Convergence (ROC): The Z-transform is valid for certain values of z , and the region where it converges is called the ROC.

3.3 Frequency Response

For LTI systems, the frequency response describes how the system responds to sinusoidal inputs at different frequencies. The frequency response

is obtained by evaluating the system's transfer function at specific frequency values:

CHAPTER 2 DIGITAL FILTER DESIGN

A.AMUDHA

Assistant Professor, Department of ECE

Ponnaiyah Ramajayam Institute of Science and Technology, Tamil Nadu, India

Digital filter design is a crucial aspect of digital signal processing (DSP), where the goal is to process a digital signal by removing or enhancing specific frequency components. Digital filters are essential in numerous applications such as audio and video processing, telecommunications, and biomedical signal analysis.

There are two main types of digital filters:

Finite Impulse Response (FIR) Filters

Infinite Impulse Response (IIR) Filters

Each type has its own advantages, challenges, and methods of design. Below is an overview of key concepts in digital filter design.

1. Types of Digital Filters

1.1 FIR (Finite Impulse Response) Filters

FIR filters have a finite number of nonzero terms in their impulse response. Their impulse response, $h[n]$

$h[n]$, is nonzero for only a finite number of points, which is why they are termed finite impulse response filters.

Characteristics:

Always stable since they don't have feedback (i.e., past outputs don't influence the future outputs).

Can be designed to have linear phase, which is critical for applications where phase distortion needs to be minimized.

Typically require a higher filter order compared to IIR filters to achieve the same sharpness in frequency response.

1.2 IIR (Infinite Impulse Response) Filters

IIR filters have an impulse response that theoretically continues indefinitely, though it may decay over time. These filters use feedback, meaning that the current output depends on previous outputs as well as current and previous inputs.

Characteristics:

Efficient in terms of computation since they typically require fewer coefficients than FIR filters to achieve a desired frequency response.

Can be unstable if not designed carefully, due to feedback.

Typically non-linear phase, which may introduce phase distortion in some applications.

2. Digital Filter Design Specifications

Digital filter design begins with a set of specifications based on the desired frequency response of the filter.

Typical specifications include:

Pass band: The range of frequencies that the filter allows to pass with minimal attenuation.

Stop band: The range of frequencies that the filter attenuates significantly.

Transition band: The frequency range between the pass band and stop band, where the signal is gradually attenuated.

CHAPTER 3 APPLICATIONS OF DIGITAL FILTERS

S.SARASWATHY

Associate Professor, Department of ECE

Ponnaiyah Ramajayam Institute of Science and Technology, Tamil Nadu, India.

Digital filters are widely used across many fields and industries due to their ability to process digital signals effectively and precisely. Their applications range from simple noise reduction in audio signals to complex operations in telecommunications and biomedical signal processing. Here's a detailed look at key applications of digital filters:

1. Audio Signal Processing

Digital filters are extensively used in the processing of audio signals for various purposes such as sound enhancement, noise reduction, and equalization.

1.1 Equalization

Audio equalizers use digital filters to adjust the balance of different frequency components in an audio signal. This is common in music production, mixing, and playback systems.

Example: Boosting the bass or treble in a music track.

1.2 Noise Reduction

Digital filters are used to remove background noise or unwanted sounds from audio recordings. For instance, low-pass filters can eliminate high-frequency noise, and band-stop filters can remove specific frequencies like hums or buzzes.

Example: Removing hiss noise from old audio recordings.

1.3 Echo and Reverb Cancellation

In communication systems, digital filters help in reducing unwanted echo and reverb, especially in teleconferencing systems.

Adaptive filters adjust their parameters based on the incoming signal to minimize the effect of echoes dynamically.

2. Image and Video Processing

In digital image and video processing, digital filters are crucial for enhancing image quality, noise reduction, and feature extraction.

2.1 Image Smoothing and Sharpening

Digital filters like low-pass filters (also called smoothing filters) are used to reduce noise and smooth images by averaging neighboring pixel values.

High-pass filters or sharpening filters highlight edges and fine details by enhancing differences between neighboring pixels.

2.2 Edge Detection

Filters such as Sobel, Prewitt, or Laplacian filters are used to detect edges in images by finding areas with rapid intensity changes, which helps in image segmentation and object recognition.

2.3 Compression

Digital filters are used in the compression of images and videos by eliminating redundant or less important information (e.g., in JPEG and MPEG compression algorithms). Wavelet transforms and Fourier transforms are common techniques that involve filtering.

CHAPTER 4 SAMPLING AND QUANTIZATION

P.GEETHA

*Assistant Professor, Department of ECE
Ponnaiyah Ramajayam Institute of Science and Technology, Tamil Nadu, India.*

Sampling and quantization are fundamental concepts in digital signal processing (DSP) that enable the conversion of continuous signals into digital form for processing by computers and other digital systems. They involve transforming a signal from its analog, continuous form into a digital, discrete-time representation while preserving important information about the signal.

1. Sampling

Sampling is the process of converting a continuous-time signal into a discrete-time signal by taking measurements (samples) of the signal at uniform time intervals.

1.1 Continuous vs. Discrete Signals

Continuous-time signal: A signal that is defined at every instant in time (e.g., an audio waveform, temperature over time).

Discrete-time signal: A signal that is defined only at specific time intervals, resulting from sampling the continuous-time signal (e.g., digital audio stored as discrete values).

1.2 Sampling Process

The sampling process takes the value of the continuous signal at regular intervals. These intervals are determined by the sampling rate or sampling frequency.

1.3 Nyquist Theorem (Nyquist-Shannon Sampling Theorem)

The Nyquist theorem provides a fundamental guideline for choosing the sampling rate to avoid information loss during sampling.

1.4 Aliasing

Aliasing occurs when a signal is sampled below the Nyquist rate, causing different frequency components to overlap and appear as lower frequencies in the sampled signal. This makes it impossible to correctly reconstruct the original signal.

Prevention of aliasing: To avoid aliasing, a low-pass filter is typically applied to the signal before sampling. This filter, called an anti-aliasing filter, removes high-frequency components above half the sampling rate.

Quantization

After sampling, the next step in converting an analog signal to a digital signal is quantization.

Quantization involves approximating the continuous amplitude values of the sampled signal to discrete levels.

2.1 Quantization Process

Each sampled value of the signal is rounded or mapped to the nearest value in a finite set of discrete amplitude levels, representing the signal with a finite number of bits.

Quantization levels: The number of discrete amplitude values that the sampled signal can be assigned to. These levels are determined by the bit depth or resolution of the system.

For example, in an 8-bit system, there are

2.2 Quantization Error

Quantization error (or quantization noise) is the difference between the actual continuous value of the sampled signal and its quantized value. This error arises because the continuous signal's amplitude is approximated to the nearest available quantization level.

CHAPTER 5 APPLICATIONS OF DSP

S.MAHESWARAN

Assistant Professor, Department of ECE

Ponnaiyah Ramajayam Institute of Science and Technology, Tamil Nadu, India.

Digital Signal Processing (DSP) has a wide range of applications across various fields due to its ability to process signals efficiently and accurately. Below are key applications of DSP in different domains:

1. Audio and Speech Processing

1.1 Audio Enhancement and Equalization

DSP techniques are used in audio equalizers to adjust different frequency bands (bass, mid, treble) for music production, playback systems, and personal audio devices.

DSP is also applied for noise reduction and sound enhancement in audio recordings, helping improve clarity by removing background noise or hiss.

1.2 Speech Compression

In communication systems, DSP is used for speech coding and compression, reducing the amount of data required to transmit voice signals. Techniques like Linear Predictive Coding (LPC) and Code-Excited Linear Prediction (CELP) are widely used in mobile phones and VoIP systems.

1.3 Voice Recognition and Synthesis

DSP is crucial in speech recognition systems for converting spoken words into text, as seen in voice assistants like Siri, Alexa, and Google Assistant.

It is also used in text-to-speech synthesis, enabling computers to "speak" by converting written text into speech.

2. Image and Video Processing

2.1 Image Enhancement

DSP algorithms are applied to enhance digital images by improving their quality through techniques like contrast adjustment, sharpening, and noise reduction. These techniques are common in photo editing software.

2.2 Image Compression

JPEG and MPEG are compression standards that use DSP techniques like the Discrete Cosine Transform (DCT) to reduce the size of images and videos for storage and transmission, while preserving visual quality.

2.3 Video Processing

DSP is essential in video streaming for encoding and compressing video files (e.g., MP4), making it feasible to stream over limited bandwidth without significant loss of quality.

DSP techniques like motion detection and frame interpolation are used in video surveillance and high-definition video playback to improve smoothness.

2.4 Object Recognition

DSP plays a role in object and face recognition systems used in security applications, autonomous vehicles, and smart cameras. Techniques like edge detection and pattern recognition are applied to detect and classify objects in digital images.

3. Telecommunications

3.1 Modulation and Demodulation

DSP is used for modulation and demodulation of signals in communication systems like mobile phones, Wi-Fi, and satellite communications. Techniques like Quadrature Amplitude Modulation (QAM) and Frequency Shift Keying (FSK) rely on DSP for efficient transmission of data.



LINEAR INTEGRATED CIRCUITS LABORATORY MANUAL

Edited by

S.LILLYPET



978-93-6255-286-0

LINEAR INTEGRATED CIRCUITS LABORATORY MANUAL

COPYRIGHT @ 2023 BY S.LILLYPET

ALL RIGHTS RESERVED. NO PART OF THIS BOOK MAY BE
REPRODUCED OR TRANSMITTED IN ANY FORM OR BY ANY MEANS
WITHOUT WRITTEN PERMISSION FROM THE AUTHOR.

ISBN: 978-93-6255-286-0

PUBLISHER: Ponnaiyah Ramajayam Institute of Science and Technology
(PRIST)

CONTENTS

| Sl. No. | Date | Name of the Experiment |
|---------|------|--|
| 1. | | AC and DC Amplifiers |
| 2. | | Op-Amp DC Applications |
| 3. | | Op-amp Integrator and Differentiator |
| 4. | | Butterworth low pass and high pass Filters |
| 5. | | Band pass and Band reject filters |
| 6. | | Schmitt Triggers |
| 7. | | Square wave & Triangular wave generator |
| 8. | | Astable Multivibrator using 555 timer |
| 9. | | Voltage Regulator using IC723 |
| 10. | | Simulation experiments: i. State variable and switched capacitor filter ii. Switching voltage regulator iii. Precision rectifiers iv. Instrumentation amplifiers v. Amplitude modulation using analog multiplier Note: Design and simulate the opamp applications using appropriate tools. |

Experiment – I

Design and testing of Op-amp AC and DC amplifiers

Aim: To design and test the following Op-Amp AC and DC amplifiers:

1. Inverting amplifier
2. Non-inverting amplifier
3. Voltage Follower

Components required:

| Sl.No | Components/Equipment's Required | Specifications | Quantity |
|-------|---------------------------------|-------------------|-------------|
| 1. | Op-amp | μ A741 | 1 |
| 2. | Resistors | As per the design | As required |
| 3. | Capacitors | As per the design | As required |
| 4. | DC regulated power supply | 0-15V | 1 |
| 5. | CRO | - | 1 |
| 6. | Signal generator | - | 1 |
| 7. | Breadboard | - | 1 |
| 8. | Connecting wires | - | As required |

Pre-requisites:

1. Op-amp basics.
2. Op-amp AC and DC amplifiers.
3. Pin details and power supply connection for μ A741.
4. Working of Op-amp as Zero Crossing Detector (ZCD).
5. Frequency response.
6. Mathematical relations for gain, input impedance and bandwidth.

Zero Crossing Detector(ZCD) circuit diagram:

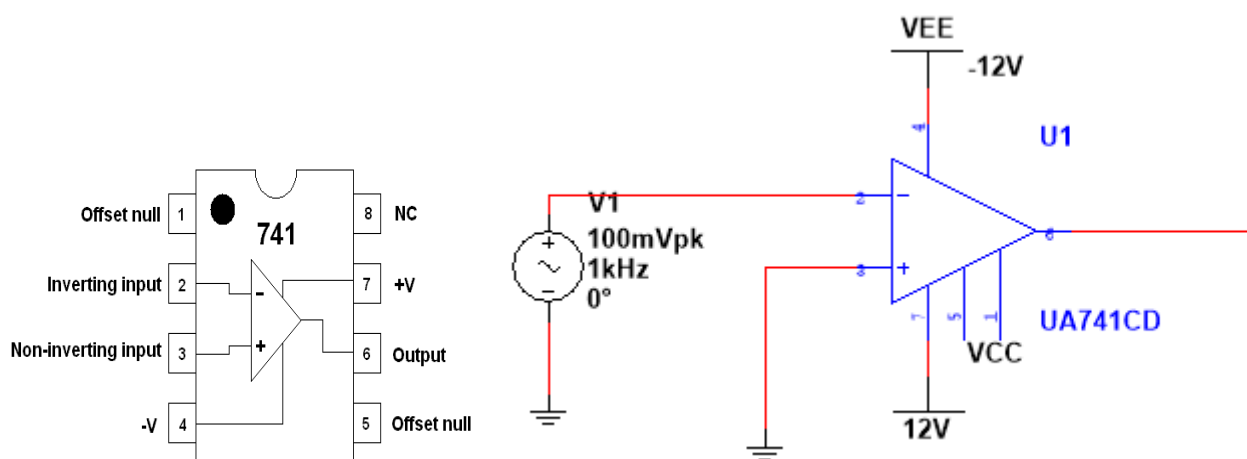

Figure 1.1(a) Pin diagram (b) Circuit for testing Op-amp as ZCD.

Procedure:

1. The circuit is set-up as shown in figure 1.1. The supply voltage $\pm V_{CC}$ is set at $\pm 14V$.
2. Apply the sinusoidal input signal with $100mV_{(p-p)}$ amplitude with 1kHz frequency to the inverting input terminal.
3. Observe the output at pin 6 of the $\mu A741$ opamp. We observe the square wave which has the amplitude equal to $\pm V_{sat}$.
4. Theoretical $\pm V_{sat}$ has to be calculated using $\pm V_{sat} = 90\%$ of V_{CC} .
5. The Op-amp circuit in figure 1.1 can be tested as non-inverting ZCD by interchanging the connections at the terminals pin 2 & 3.

Observations & Calculations:

1. Inverting Amplifiers

1.1 DC Amplifier

Circuit Design:

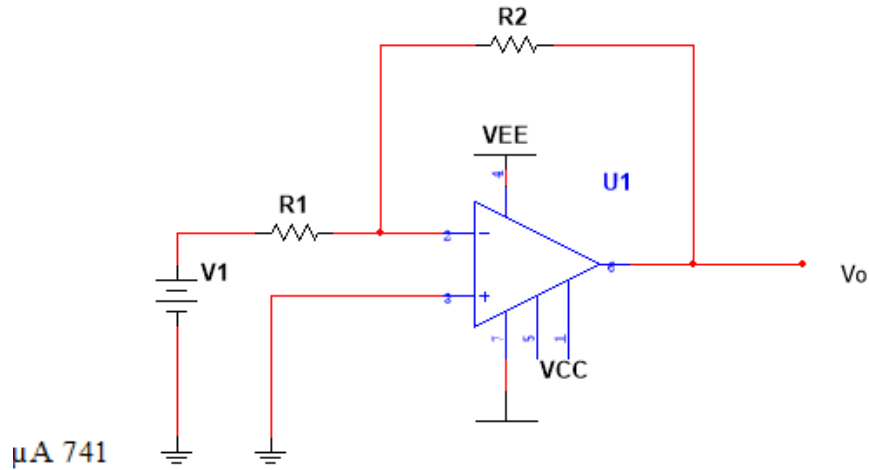

Fig 1.2: Inverting DC amplifier

Design Specifications:

$$A_F = -5$$

$$\text{Let } A_F = \frac{-R_f}{R} = -5$$

$$-5 = \frac{-R_f}{R}$$

Choose R_1 and calculate R_F

$$R_F =$$

$$R_1 =$$

Procedure:

1. The Op-amp is tested for ZCD.
2. The circuit is set-up as shown in figure 1.2. The supply voltage $\pm V_{CC}$ is set at $\pm 14V$.
3. For different value of DC regulated power supply voltage V_{in} , note down the corresponding output voltage.
4. Tabulated the readings and then compare with the calculated theoretical values.

Tabular Column:

Table 1.1: Op-amp as Inverting DC amplifier

| V_{in} in volts | $V_{o(th)}$ in volts | $V_{o(practical)}$ in volts |
|-------------------|----------------------|-----------------------------|
| | | |
| | | |
| | | |
| | | |
| | | |

Observations & Calculations:

2. Non-Inverting Amplifier

Circuit Design:

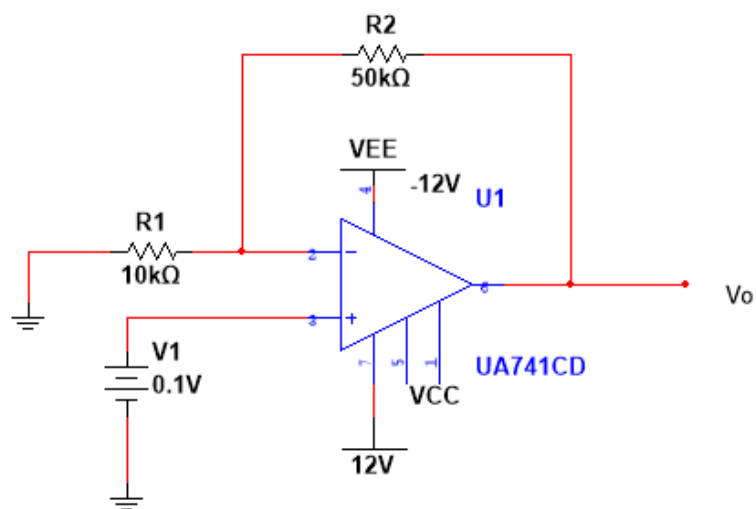

Fig 1.3: Op-amp as non-inverting DC amplifier

Design Specifications:

$A_F = 20$

Procedure:

1. The Op-amp is tested for ZCD.
2. The circuit is set-up as shown in figure 1.3. The supply voltage $\pm V_{CC}$ is set at $\pm 14V$.
3. For different value of DC regulated power supply voltage V_{in} , note down the corresponding output voltage.
4. Tabulate the readings, then compare with the calculated theoretical values.

Tabular Column:

Table 1.2: Op-amp as Non-Inverting DC amplifier

| V_{in} in volts | $V_{o(th)}$ in volts | $V_{o(practical)}$ in volts |
|-------------------|----------------------|-----------------------------|
| | | |
| | | |
| | | |
| | | |
| | | |

Observations & Calculations:

Voltage Follower

Circuit Design:

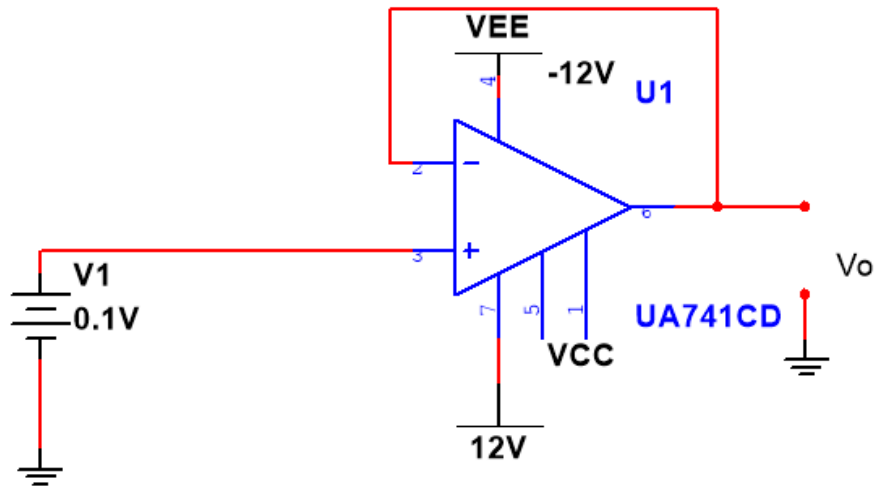

Fig 1.4: Op-amp Voltage follower

Procedure:

1. The Op-amp is tested for ZCD.
2. The circuit is set-up as shown in figure 1.4. The supply voltage $\pm V_{CC}$ is set at $\pm 14V$.
3. For different value of DC regulated power supply voltage V_{in} , note down the corresponding output voltage.
4. Tabulated the readings, then compare with the calculated theoretical values.

Observations & Calculations:

Table 1.3: Op-amp as Voltage follower

| V_{in} in volts | $V_{o(th)}$ in volts | $V_{o(practical)}$ in volts |
|-------------------|----------------------|-----------------------------|
| | | |
| | | |
| | | |
| | | |
| | | |

Observations & Calculations:

1.2 AC Amplifier

Inverting AC amplifier

Circuit Design:

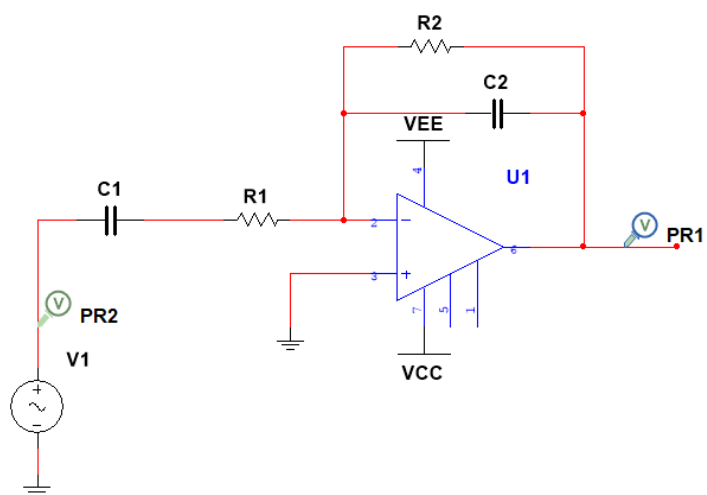

Fig 1.5: Op-amp Inverting AC amplifier

Design Specifications:

a) Without C_F :

$$\text{Let } |A_{vf}|_{(\text{mid})} = -10$$

$$Z_{if} = \underline{\hspace{2cm}}$$

$$F_L = \underline{\hspace{2cm}}$$

$$Z_{if} = R = \underline{\hspace{2cm}}$$

$$|A_{vf}|_{(\text{mid})} = -10 = \frac{-R_f}{R}$$

$$R_f = \underline{\hspace{2cm}}$$

$$F_L = \frac{1}{2\pi RC}, C = \underline{\hspace{2cm}}$$

$$F_H = \frac{10^6}{|A_{vf}|_{(\text{mid})}} = \underline{\hspace{2cm}}$$

b) With C_F :

$$\text{To fix } F_H = \underline{\hspace{2cm}}$$

$$F_H = \frac{1}{2\pi R_f C_F}$$

$$C_F = \underline{\hspace{2cm}}$$

Procedure:

1. The Op-amp is tested for ZCD.
2. The circuit is setup as shown in figure 1.5. The supply voltage ($\pm V_{CC}$) is set at $\pm 15V$. The input to the circuit is $1V_{(p-p)}$ AC supply.
3. Vary the frequency of the input ac voltage source and note down the corresponding output voltage reading ($V_{O(p-p)}$).
4. Tabulate the readings from the results obtained, plot the frequency response of the circuit.
5. After tabulation, measure the values of mid-band gain, input and output impedances and bandwidth. Then, compare the results with the corresponding theoretical values calculated.

Non-Inverting AC Amplifier

Circuit Diagram:

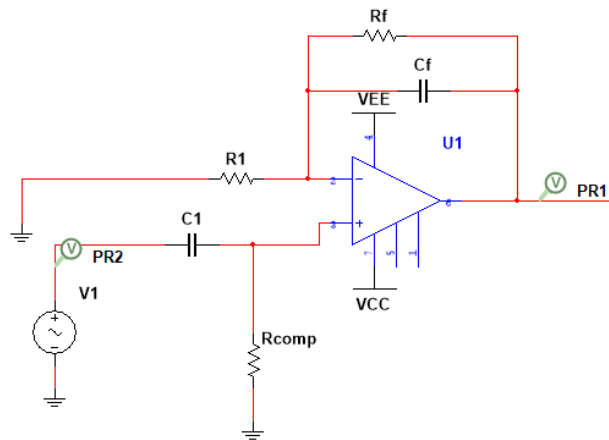

Fig 1.6: Op-Amp as Non-Inverting AC amplifier

Design:

a) Without C_F :

Let $|A_{Vf}|_{(mid)} = \underline{\hspace{2cm}}$

$Z_{if} = \underline{\hspace{2cm}}$

$F_L = \underline{\hspace{2cm}}$

$Z_{if} = R_{comp} = \underline{\hspace{2cm}}$

$R_{comp} = R_f || R$

$|A_{Vf}|_{(mid)} = \underline{\hspace{2cm}} = 1 + \frac{R_f}{R}$

$R_f = \underline{\hspace{2cm}}$

$R = \underline{\hspace{2cm}}$

$F_L = \frac{1}{2\pi RC}, C = \underline{\hspace{2cm}}$

$F_H = \frac{10^6}{|A_{Vf}|_{(mid)}} = \underline{\hspace{2cm}}$

b) With C_F :

To fix $F_H =$

$$F_H = \frac{1}{2\pi R_F C_F}$$

$C_F = \underline{\hspace{2cm}}$

Procedure:

1. The Op-amp is tested for ZCD.
2. The circuit is setup as shown in figure 1.6. The supply voltage ($\pm V_{CC}$) is set at $\pm 15V$. The input to the circuit is $1V_{(p-p)}$ AC supply.
3. Vary the frequency of the input ac voltage source and note down the corresponding output voltage reading ($V_{O(P-P)}$).
4. Tabulate the readings from the results obtained, plot the frequency response of the circuit.

AC Voltage follower

Circuit Diagram:

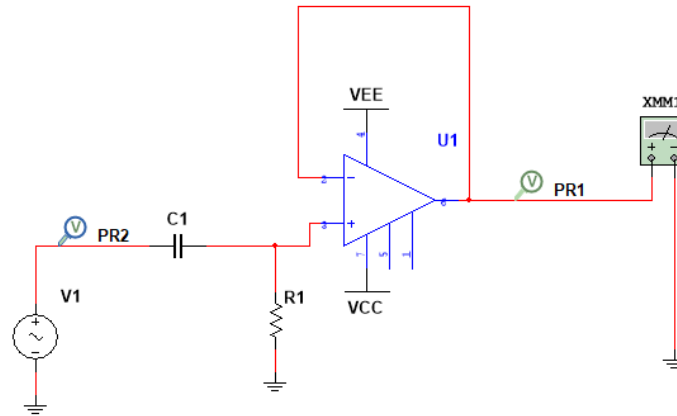

Fig 1.7: Op-Amp as AC voltage follower

Design:

$$\text{Set } F_L = \underline{\hspace{2cm}} = \frac{1}{2\pi RC}$$

$$\text{Let } C = \underline{\hspace{2cm}}$$

$$R = \underline{\hspace{2cm}}$$

$$F_H = \frac{10^6}{|A_{vf}(\text{mid})|} = \underline{\hspace{2cm}} \quad (\text{as } |A_{vf}| = 1)$$

Procedure:

1. The Op-amp is tested for ZCD.
2. The circuit is setup as shown in figure 1.7. The supply voltage ($\pm V_{CC}$) is set at $\pm 15V$. The input to the circuit is $1V_{(p-p)}$ AC supply.
3. Vary the frequency of the input ac voltage source and note down the corresponding output voltage reading ($V_{O(P-P)}$).
4. Tabulate the readings from the results obtained, plot the frequency response of the circuit.
5. After tabulation, measure the values of mid-band gain, input and output impedances and bandwidth. Then, compare the results with the corresponding theoretical values calculated.

Inference:

Advantages:

Applications:

Experiment – II

Design and testing of Op-amp DC Circuits

Aim:

To design and test the following Op-Amp DC circuits:

1. Inverting Adder circuit.
2. Inverting Averager
3. Inverting addition with scaling circuit
4. Non-inverting summer circuit
5. Non-inverting averager
6. Difference amplifier
7. Subtractor circuit

Components required:

| SL.NO | Components/Equipment's Required | Specifications | Quantity |
|-------|---------------------------------|-------------------|-------------|
| 1. | Op-amp | μ A741 | 1 |
| 2. | Resistors | As per the design | As required |
| 3. | DC regulated power supply | 0-15V | 1 |
| 4. | CRO | - | 1 |
| 5. | Signal generator | - | 1 |
| 6. | Breadboard | - | 1 |
| 7. | Connecting wires | - | As required |

Pre-requisites:

1. Op-amp basics.
2. Op-amp DC circuits.
3. Pin details and power supply connection for μ A741.
4. Working of Op-amp as ZCD.

Inverting Adder Circuit

Circuit Diagram:

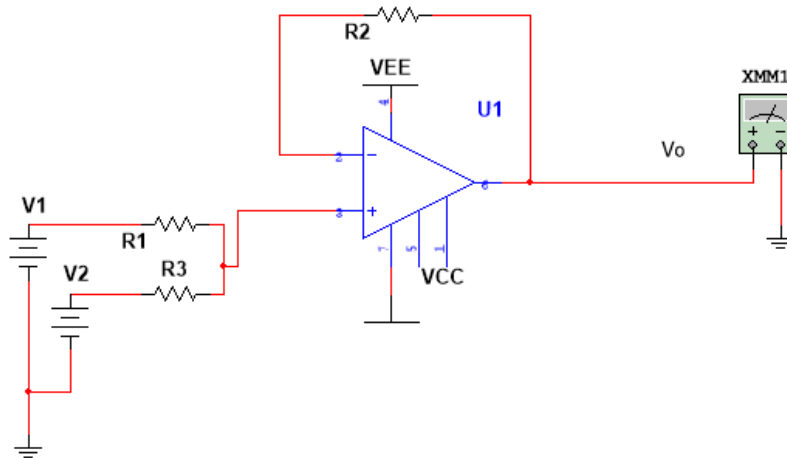

Fig 2.1: Op-amp as inverting Adder

Design:

We have $V_0 = -[aV_1 + bV_2]$

Where $a = \frac{R_f}{R_1}$, $b = \frac{R_f}{R_2}$

If we take $a = b = 1$

$V_0 = -[V_1 + V_2]$

Select R_1 , R_2 and R_F suitably.

$R_1 = \underline{\hspace{2cm}}$

$R_2 = \underline{\hspace{2cm}}$

$R_F = \underline{\hspace{2cm}}$

Procedure:

1. The Op-amp is tested for ZCD.
2. The circuit is set-up as shown in figure 2.1. The supply voltage $\pm V_{CC}$ is set at $\pm 12V$.
3. For different value of DC regulated power supply voltage V_{in} , note down the corresponding output voltage.
4. Tabulate the readings, then compare with the calculated theoretical values calculated using the formula $V_0 = -[V_1 + V_2]$.

Tabular Column:

Table 2.1: Op-amp as Inverting DC amplifier

| V_1 in volts | V_2 in volts | $V_{o(th)}$ in volts | $V_{o(practical)}$ in volts |
|----------------|----------------|----------------------|-----------------------------|
| | | | |
| | | | |
| | | | |
| | | | |
| | | | |

Observations & Calculations:

Inverting DC Averager

Circuit Diagram:

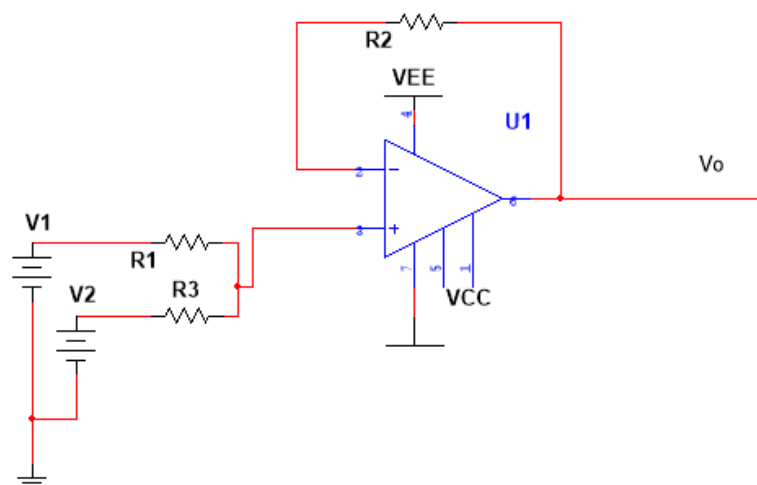

Fig 2.2: Op-amp as Inverting DC averager

Design:

We have $V_0 = -[aV_1 + bV_2]$

Where $a = \frac{R_f}{R_1}$, $b = \frac{R_f}{R_2}$

If we take $a = b = \frac{1}{2}$

$$V_0 = -\frac{1}{2} [V_1 + V_2]$$

Select R_1 , R_2 and R_F suitably.

$R_1 =$ _____

$R_2 =$ _____

$R_F =$ _____

Procedure:

1. The Op-amp is tested for ZCD.
2. The circuit is set-up as shown in figure 2.2. The supply voltage $\pm V_{CC}$ is set at $\pm 12V$.
3. For different value of DC regulated power supply voltage V_{in} , note down the corresponding output voltage.
4. Tabulate the readings, then compare with the calculated theoretical values calculated using the formula $V_0 = -\frac{1}{2} [V_1 + V_2]$.

Tabular Column:

Table 2.2: Op-amp as Inverting DC averager

| V_1 in volts | V_2 in volts | $V_{o(th)}$ in volts | $V_{o(practical)}$ in volts |
|----------------|----------------|----------------------|-----------------------------|
| | | | |
| | | | |
| | | | |
| | | | |
| | | | |

Observations & Calculations:

Inverting DC adder with scaling

Circuit Diagram:

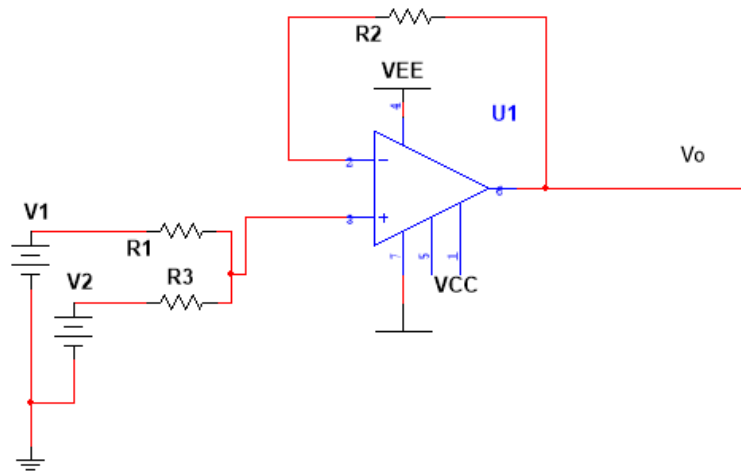

Fig 2.3: Op-amp as Inverting DC adder with scaling

Design:

We have $V_0 = -[aV_1 + bV_2]$

Where $a = \frac{R_f}{R_1}$, $b = \frac{R_f}{R_2}$

If we take $a = b =$

$V_0 = -2 [V_1 + V_2]$

Select R_1 , R_2 and R_F suitably.

$R_1 =$ _____

$R_2 =$ _____

$R_F =$ _____

Procedure:

1. The Op-amp is tested for ZCD.
2. The circuit is set-up as shown in figure 2.3. The supply voltage $\pm V_{CC}$ is set at $\pm 12V$.
3. For different value of DC regulated power supply voltage V_{in} , note down the corresponding output voltage.
4. Tabulate the readings, then compare with the calculated theoretical values calculated using the formula $V_0 = -2[V_1 + V_2]$.

Tabular Coulmn:

Table 2.3: Op-amp as Inverting DC adder with scaling

| V_1 in volts | V_2 in volts | $V_{o(th)}$ in volts | $V_{o(practical)}$ in volts |
|----------------|----------------|----------------------|-----------------------------|
| | | | |
| | | | |
| | | | |
| | | | |
| | | | |

Observations & Calculations:

Non-Inverting DC adder circuit

Circuit Diagram:

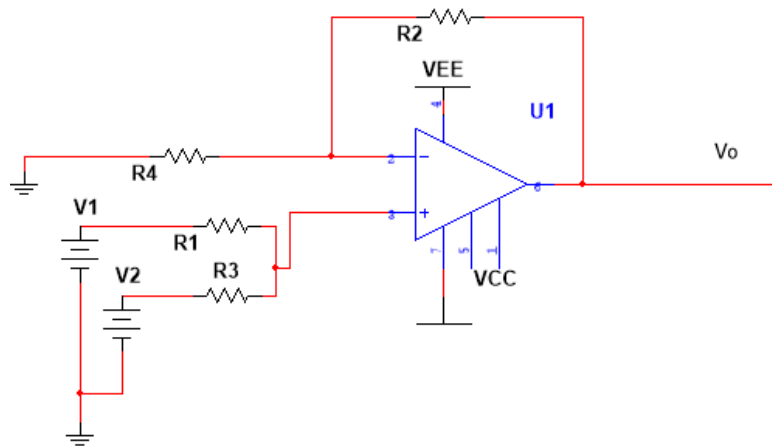

Fig 2.4: Non-inverting DC adder circuit

Design:

We have $V_0 = \frac{1}{2} [V_1 + V_2] (1 + \frac{R_f}{R_1})$

Where $(1 + \frac{R_f}{R_1}) = 2$

$V_0 = [V_1 + V_2]$

Select R_1 , R_2 and R_F suitably.

$R = \underline{\hspace{2cm}}$

$R_1 = \underline{\hspace{2cm}}$

$R_F = \underline{\hspace{2cm}}$

Procedure:

1. The Op-amp is tested for ZCD.
2. The circuit is set-up as shown in figure 2.4. The supply voltage $\pm V_{CC}$ is set at $\pm 12V$.
3. For different value of DC regulated power supply voltage V_{in} , note down the corresponding output voltage.
4. Tabulate the readings, then compare with the calculated theoretical values calculated using the formula $V_0 = [V_1 + V_2]$.

Tabular Column:

Table 2.4: Op-amp as Non-Inverting DC adder

| V_1 in volts | V_2 in volts | $V_{o(th)}$ in volts | $V_{o(practical)}$ in volts |
|----------------|----------------|----------------------|-----------------------------|
| | | | |
| | | | |
| | | | |
| | | | |
| | | | |

Observations & Calculations:

Non-Inverting DC average

Circuit Diagram:

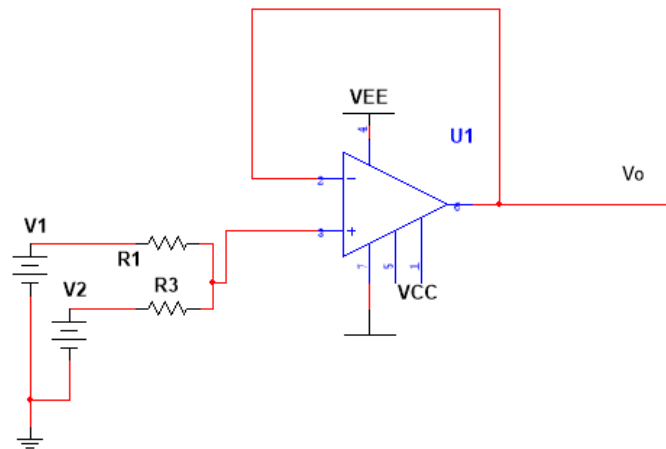

Fig 2.5: Op-amp as Non-inverting DC Averager

Design:

$$\text{We have } V_0 = \frac{1}{2} [V_1 + V_2] \left(1 + \frac{R_f}{R_1}\right)$$

$$\text{Where } \left(1 + \frac{R_f}{R_1}\right) = 1$$

$$V_0 = \frac{1}{2} [V_1 + V_2]$$

Select R, short Pin 2&6.

$$R = \underline{\hspace{2cm}}$$

Procedure:

1. The Op-amp is tested for ZCD.
2. The circuit is set-up as shown in figure 2.5. The supply voltage $\pm V_{CC}$ is set at $\pm 12V$.
3. For different value of DC regulated power supply voltage V_{in} , note down the corresponding output voltage.
4. Tabulate the readings, then compare with the calculated theoretical values calculated using the formula $V_0 = \frac{1}{2} [V_1 + V_2]$.

Tabular Column:

Table 2.5: Op-amp as Non-Inverting DC averager

| V_1 in volts | V_2 in volts | $V_{o(th)}$ in volts | $V_{o(practical)}$ in volts |
|----------------|----------------|----------------------|-----------------------------|
| | | | |
| | | | |
| | | | |
| | | | |
| | | | |

Observations & Calculations:

Difference Amplifier

Circuit Diagram:

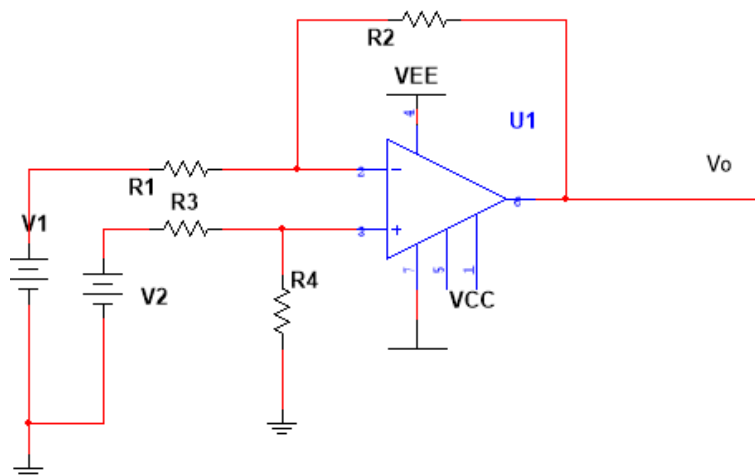

Fig 2.6: Op-amp as Difference amplifier

Design:

We have, $V_O = -\frac{R_f}{R_1}V_1 + \frac{R_3}{R_2}V_2$

If $\frac{R_f}{R_1} = \frac{R_3}{R_2}$

Then $V_O = \frac{R_f}{R_1}[V_2 - V_1] = A_d$

Choose R_F and R_1 for $A_d =$

$R_F =$ _____

$R_1 =$ _____

$R_2 =$ _____

$R_3 =$ _____

Procedure:

1. The Op-amp is tested for ZCD.
2. The circuit is set-up as shown in figure 2.6. The supply voltage $\pm V_{CC}$ is set at $\pm 12V$.
3. For different value of DC regulated power supply voltage V_{in} , note down the corresponding output voltage.
4. Tabulate the readings, then compare with the calculated theoretical values calculated using the formula $V_O = \frac{R_f}{R_1}[V_2 - V_1]$.

Tabular Column:

Table 2.6: Op-amp as Difference Amplifier

| V_1 in volts | V_2 in volts | $V_{o(th)}$ in volts | $V_{o(practical)}$ in volts |
|----------------|----------------|----------------------|-----------------------------|
| | | | |
| | | | |
| | | | |
| | | | |
| | | | |
| | | | |

Observations & Calculations:

Subtractor circuit

Circuit Diagram:

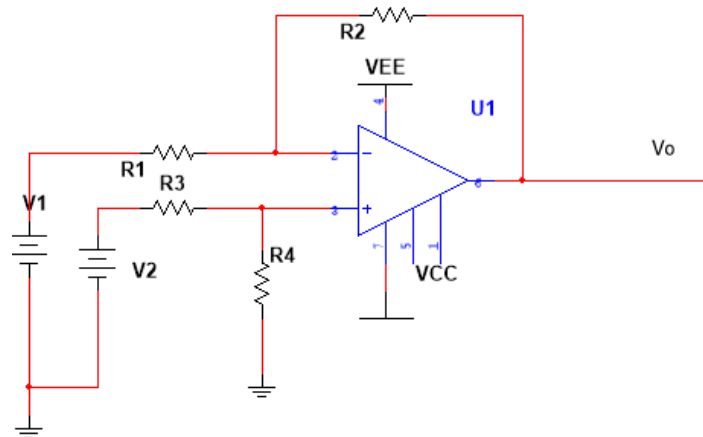

Fig 2.7: Subtractor circuit

Design:

We have, $V_O = -\frac{R_f}{R_1}V_1 + \frac{R_3}{R_2}V_2$

$$\text{If } \frac{R_f}{R_1} = \frac{R_3}{R_2}$$

Then $V_O = [V_2 - V_1] = A_d$

Choose R_F and R_1 for $A_d =$

$$R_F = \underline{\hspace{2cm}}$$

$$R_1 = \underline{\hspace{2cm}}$$

$$R_2 = \underline{\hspace{2cm}}$$

$$R_3 = \underline{\hspace{2cm}}$$

Procedure:

1. The Op-amp is tested for ZCD.
2. The circuit is set-up as shown in figure 2.7. The supply voltage $\pm V_{CC}$ is set at $\pm 12V$.
3. For different value of DC regulated power supply voltage V_{in} , note down the corresponding output voltage.
4. Tabulate the readings, then compare with the calculated theoretical values calculated using the formula $V_O = [V_2 - V_1]$.

Tabular Column:

Table 2.7: Op-amp as Difference Amplifier

| V_1 in volts | V_2 in volts | $V_{o(th)}$ in volts | $V_{o(practical)}$ in volts |
|----------------|----------------|----------------------|-----------------------------|
| | | | |
| | | | |
| | | | |
| | | | |
| | | | |

Observations & Calculations:

Inference:

Advantages:

Applications:

Experiment – III

Design and testing of Op-amp Integrator & Differentiator

Aim:

To design and test Op-amp Integrator & Differentiator

1. Obtain its frequency response.
2. Find salient frequencies f_1 & f_2 .
3. Find $|A_F(\omega)|$ and $\theta(\omega)$ at the frequencies $f < f_1$, $f = f_1$, $f > f_1$.

Components Required:

| SL.NO | Components/Equipment's Required | Specifications | Quantity |
|-------|---------------------------------|-------------------|-------------|
| 1. | Op-amp | $\mu A741$ | 1 |
| 2. | Resistors | As per the design | As required |
| 3. | Capacitors | As per the design | As required |
| 4. | DC regulated power supply | 0-15V | 1 |
| 5. | CRO | - | 1 |
| 6. | Signal generator | - | 1 |
| 7. | Breadboard | - | 1 |
| 8. | Connecting wires | - | As required |

Pre-requisites:

1. Operation of basic Op-amp Integrator, Differentiator and its drawbacks.
2. Operation of practical Integrator & Differentiator
3. Response of Integrator and Differentiator for square wave input.
4. Concept of poles and zeros.

Circuit Diagram:

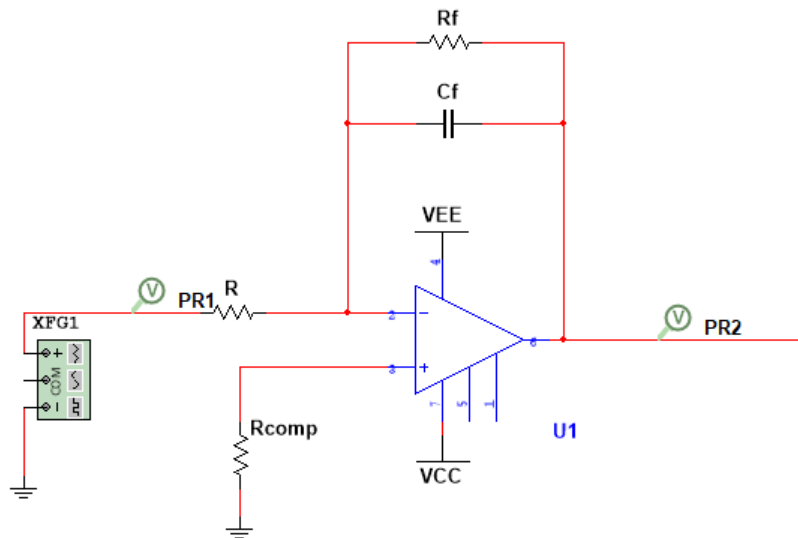

Fig 3.1: Op-amp Integrator

Design Specifications:

$|A_f| = \text{_____} = \text{DC gain}$

Choose, $C_f = \text{_____}$,

To integrate all frequencies $\geq 1\text{kHz}$

$R_f = \text{_____}$.

Design Procedure:

$|A_f| = \frac{R_f}{R} =$

Lowest frequency to be integrated, $f_{\min} = \text{_____}$

For proper integration, $f_1 < f_{\min}$

$R = \text{_____}$

Let $f_1 = \frac{f_{\min}}{10} = \text{_____}$

$R_{\text{COMP}} = R_1 || R_f$

$R_{\text{COMP}} = \text{_____}$

$f_1 = \frac{1}{2\pi R_f C_f} =$

$f_2 = \frac{1}{2\pi R C_f} = \text{_____}$

Procedure:

1. Test the Op-Amp as ZCD.
2. Setup the circuit as shown in figure 3.1.
3. Obtain frequency and phase responses.
4. Compute and compare the magnitude and phase values with the corresponding theoretical values for at least five frequencies.

Table 3.3: Comparison of Practical and theoretical values of $|A_V|$ and θ .

$$|A_V| = \frac{R_f/R_1}{\sqrt{1+(\frac{f}{f_1})^2}}$$

$$\theta_{(th)} = 180^\circ - \tan^{-1}(\frac{f}{f_1})$$

| Frequency | $\theta_{(practical)}$ | $\theta_{(theoretical)}$ | $ A_V _{(practical)}$ | $ A_V _{(theoretical)}$ |
|-----------|------------------------|--------------------------|-----------------------|-------------------------|
| | | | | |
| | | | | |
| | | | | |
| | | | | |
| | | | | |
| | | | | |
| | | | | |

Table 3.4: Response for Square wave input [$f < f_1$, $f = f_1$, $f > f_1$]

$$V_i = \underline{\hspace{2cm}}$$

$$V_{O (P-P) (theoretical)} = \frac{V}{4fRC_F}$$

| Frequency | $V_{o (p-p) (practical)}$ | $V_{o (p-p) (theoretical)}$ |
|-----------|---------------------------|-----------------------------|
| | | |
| | | |
| | | |
| | | |
| | | |
| | | |
| | | |

Table 3.5: Comparison of practical and theoretical values of f_1 & f_2 .

| SL.NO | Parameter | Theoretical values | Practical values |
|-------|----------------|--------------------|------------------|
| 1. | $ A_f _{(DC)}$ | | |
| 2. | f_1 | | |
| 3. | f_2 | | |

Lissajous patten for six different frequencies [$f < f_1$, $f = f_1$, $f > f_1$]

| | |
|----------|----------|
| 1. $f =$ | 2. $f =$ |
| 3. $f =$ | 4. $f =$ |
| 5. $f =$ | 6. $f =$ |

Square wave response for six different frequencies [Plot output waveforms super imposed on the input waveforms]

| | |
|----------|----------|
| 1. $f =$ | 2. $f =$ |
| 3. $f =$ | 4. $f =$ |
| 5. $f =$ | 6. $f =$ |

Observations & calculations:

3.2: Differentiator

Circuit Diagram:

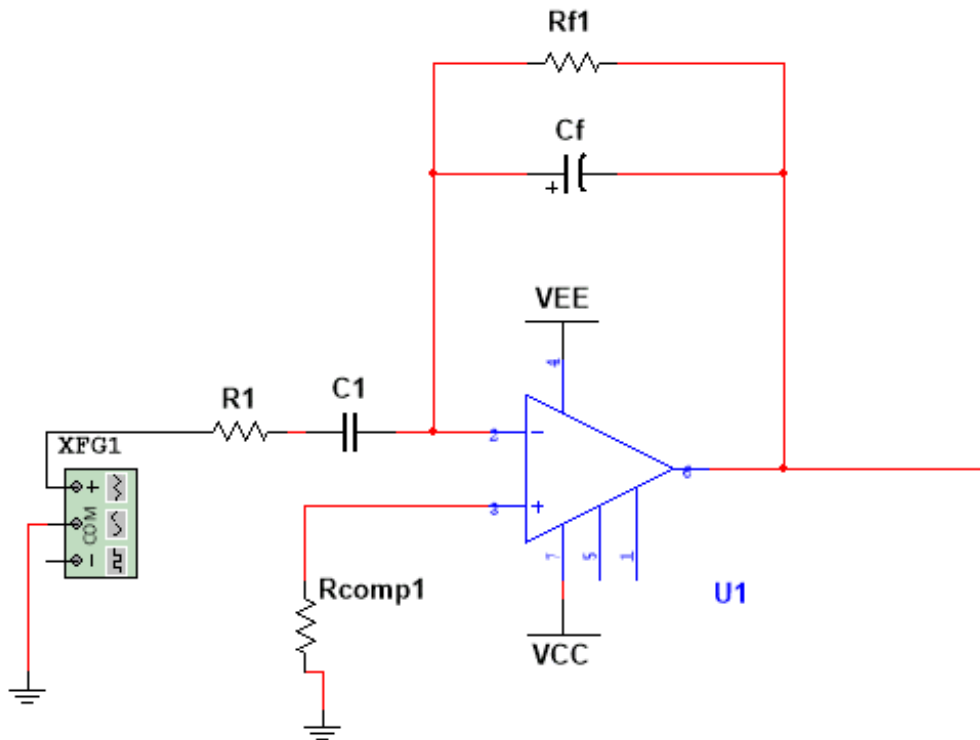

Fig 3.1: Op-amp as a Differentiator

Design Specifications:

To differentiate all frequencies $\leq 1\text{kHz}$

$$f_1 = \frac{1}{2\pi R_F C_1},$$

Let us keep $f_1 < f_{\max}$, Take $f_1 = \frac{f_{\max}}{5}$

Design Procedure:

Highest frequency to be differentiated, $f_{\max} = \underline{\hspace{2cm}}$

$$f_1 = \underline{\hspace{2cm}}$$

$$C_1 = \underline{\hspace{2cm}}$$

For proper differentiation, $f_{\max} < f_2$

Let $f_2 = 5 * f_{\max}$, $f_2 = \underline{\hspace{2cm}}$

$$f_2 = \frac{1}{2\pi R_F C_F} = \frac{1}{2\pi R_1 C_1}$$

W.k.t $R_f C_f = R_1 C_1$, $R_1 = \underline{\hspace{2cm}}$

$$R_{\text{COMP}} = R_1 || R_f$$

Choose, $C_f = \underline{\hspace{2cm}}$,

$$R_{\text{COMP}} = \underline{\hspace{2cm}}$$

$R_f = \underline{\hspace{2cm}}$.

Procedure:

1. The Op-amp is tested as ZCD.
2. Setup the circuit as shown in figure 3.1.
3. Obtain frequency and phase responses.
4. Compute and compare the magnitude and phase values with the corresponding theoretical values for at least five frequencies.
5. The output with square wave input is observed, compare the theoretical and practical voltage for at least five frequencies.

Observations & calculations:

Table 3.6: Frequency of Op-amp Differentiator $V_i = 1V_{(p-p)}$

| Frequency (Hz) | $V_{O(P-P)}$ (V) | Gain (V_O/V_i) | $ A_v = 20\log\frac{V_o}{V_i}$ in dB |
|----------------|------------------|--------------------|---------------------------------------|
| | | | |
| | | | |
| | | | |
| | | | |
| | | | |
| | | | |
| | | | |
| | | | |
| | | | |
| | | | |
| | | | |
| | | | |
| | | | |
| | | | |
| | | | |
| | | | |
| | | | |
| | | | |

Table 3.7: Phase response

$V_i = \underline{\hspace{2cm}}$

| Frequency (Hz) | Y-Intercept | H-Intercept | $\theta_{(practical)} = 180^\circ - \sin^{-1}(\frac{Y}{H})$ |
|----------------|-------------|-------------|---|
| | | | |
| | | | |
| | | | |
| | | | |
| | | | |
| | | | |

Table 3.8: Comparison of Practical and theoretical values of $|A_v|$ and θ .

$|A_v| = \omega R_F C_1$

$\theta_{(th)} = -90^\circ - 2\tan^{-1}(\frac{f}{f_2})$

| Frequency | $\theta_{(practical)}$ | $\theta_{(theoretical)}$ | $ A_v _{(practical)}$ | $ A_v _{(theoretical)}$ |
|-----------|------------------------|--------------------------|-----------------------|-------------------------|
| | | | | |
| | | | | |
| | | | | |
| | | | | |
| | | | | |
| | | | | |

Table 3.9: Response for Square wave input [$f < f_1$, $f = f_1$, $f_1 < f < f_2$]

$V_i = \underline{\hspace{2cm}}$

$V_O (P-P) (theoretical) = \underline{V_{sat}}$

| Frequency | $V_o (p-p) (practical)$ | $V_o (p-p) (theoretical)$ |
|-----------|-------------------------|---------------------------|
| | | |
| | | |
| | | |
| | | |
| | | |
| | | |

Table 3.10: Comparison of practical and theoretical values of f_1 & f_2 .

| SL.NO | Parameter | Theoretical values | Practical values |
|-------|-----------|--------------------|------------------|
| 1. | f_1 | | |
| 2. | f_2 | | |

Lissajous patter for six different frequencies [$f < f_1$, $f = f_1$, $f > f_1$]

| | |
|----------|----------|
| 1. $f =$ | 2. $f =$ |
| 3. $f =$ | 4. $f =$ |
| 5. $f =$ | 6. $f =$ |

Square wave response for six different frequencies [Plot output waveforms super imposed on the input waveform.]

| | |
|----------|----------|
| 1. $f =$ | 2. $f =$ |
| 3. $f =$ | 4. $f =$ |
| 5. $f =$ | 6. $f =$ |

Inference:

Advantages:

Disadvantages:

Application

Experiment – IV

Design and testing of Butterworth low pass and high pass filters

Aim:

To design and test Butterworth low pass and high pass filters,

1. Obtain their frequency response
2. Find the cut-off frequencies.
3. Find band pass gain.
4. Find the roll-off.

Components required:

| SL.NO | Components/Equipment's Required | Specifications | Quantity |
|-------|---------------------------------|-------------------|-------------|
| 1. | Op-amp | μ A741 | 1 |
| 2. | Resistors | As per the design | As required |
| 3. | Capacitors | As per the design | As required |
| 4. | DC regulated power supply | 0-15V | 1 |
| 5. | CRO | - | 1 |
| 6. | Signal generator | - | 1 |
| 7. | Breadboard | - | 1 |
| 8. | Connecting wires | - | As required |

Pre-requisites:

1. Advantages of active filters.
2. Poles of normalised Butterworth low pass and high pass filter.
3. Transfer function of low pass and high pass filters.
4. Relation between order of filter, Roll-off and number of poles.

Second order Butterworth low pass filter

Circuit Diagram:

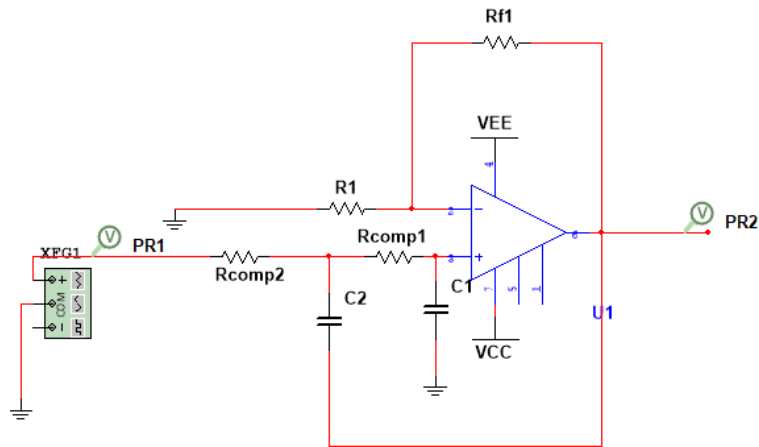

Fig 4.1: Second order Butterworth low pass filter

Design Specifications:

Cut-off frequency, $f_c = \underline{\hspace{2cm}}$

Design Procedure:

$$F_c = \frac{1}{2\pi RC}$$

Choose, $C = \underline{\hspace{2cm}}$,

$R = \underline{\hspace{2cm}}$

For second order Butterworth filter: $S_n^2 + 1.414S_n + 1$

$\alpha = \underline{\hspace{2cm}}$

$$A_0 = 1 + \frac{R_f}{R_1}$$

$\alpha = 3 - A_0$

$$\frac{R_f}{R_1} = \underline{\hspace{2cm}}$$

$A_0 = \underline{\hspace{2cm}}$

$R_f = \underline{\hspace{2cm}}$

$R_1 = \underline{\hspace{2cm}}$

$$H_{LPF}(S) = \frac{1.586}{S_n^2 + 1.414S_n + 1}$$

Observations & Calculations:

Table 4.1: Frequency response of Second order Butterworth low pass filter $V_i = \underline{\hspace{2cm}}$

| Frequency (Hz) | $V_{0\ (p-p)}$ (V) | Gain ($\frac{V_o}{V_i}$) | $ A_v = 20\log\frac{V_o}{V_i}$ in dB |
|----------------|--------------------|----------------------------|---------------------------------------|
| | | | |
| | | | |
| | | | |
| | | | |
| | | | |
| | | | |
| | | | |
| | | | |
| | | | |
| | | | |
| | | | |
| | | | |
| | | | |
| | | | |
| | | | |
| | | | |
| | | | |
| | | | |
| | | | |
| | | | |
| | | | |
| | | | |

Fourth order Butterworth low pass filter

Circuit Diagram:

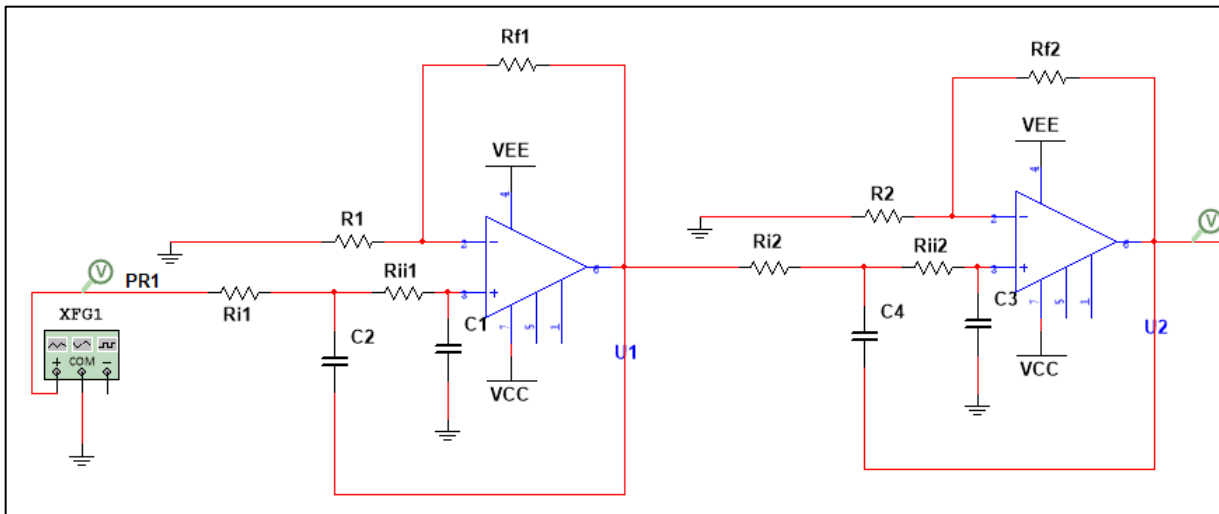

Fig 4.2: Fourth order Butterworth low pass filter

Design Specifications:

Cut-off frequency, $f_c = 4\text{kHz}$

Design Procedure:

$$F_c = \frac{1}{2\pi RC}$$

Choose, $C = \underline{\hspace{2cm}}$

$R = \underline{\hspace{2cm}}$

For fourth order Butterworth filter:

$$(S_n^2 + 0.765S_n + 1) (S_n^2 + 1.848S_n + 1)$$

$$\alpha_1 = \underline{\hspace{2cm}}$$

$$\alpha_2 = \underline{\hspace{2cm}}$$

$$\alpha = 3 - A_0$$

$$\alpha = 3 - A_0$$

$$A_0 = \underline{\hspace{2cm}}$$

$$A_0 = \underline{\hspace{2cm}}$$

$$\underline{A}_0 = 1 + \frac{Rf2}{R2}$$

$$\underline{A}_0 = 1 + \frac{Rf1}{R1}$$

$$\frac{Rf2}{R2} = \underline{\hspace{2cm}}$$

$$\frac{Rf1}{R1} = \underline{\hspace{2cm}}$$

$$Rf2 = \underline{\hspace{2cm}}$$

$$R2 = \underline{\hspace{2cm}}$$

$R_{f1} = \underline{\hspace{2cm}}$

$R_1 = \underline{\hspace{2cm}}$

$$H_{LPF}(s) = \frac{2.235}{s_n^2 + 0.765s_n + 1} \times \frac{1.152}{s_n^2 + 1.848s_n + 1}$$

Observations & Calculations:

Table 4.2: Frequency response of Fourth order Butterworth low pass filter $V_i = \underline{\hspace{2cm}}$

| Frequency (Hz) | V_0 (p-p) (V) | Gain ($\frac{V_o}{V_i}$) | $ A_v = 20 \log \frac{V_o}{V_i}$ in dB |
|----------------|-----------------|----------------------------|---|
| | | | |
| | | | |
| | | | |
| | | | |
| | | | |
| | | | |
| | | | |
| | | | |
| | | | |
| | | | |
| | | | |
| | | | |
| | | | |
| | | | |
| | | | |
| | | | |
| | | | |
| | | | |
| | | | |
| | | | |
| | | | |
| | | | |

Comparison of practical and theoretical values of cut-off frequency, pass band gain and roll-off for low pass filter:

| SL.NO | Parameter | Second order | | Fourth order | |
|-------|-------------------|--------------|-----------|--------------|-----------|
| | | Theoretical | Practical | Theoretical | Practical |
| 1. | Pass band gain | | | | |
| 2. | Cut-off frequency | | | | |
| 3. | Roll-off | | | | |

Second order Butterworth high pass filter

Circuit Diagram:

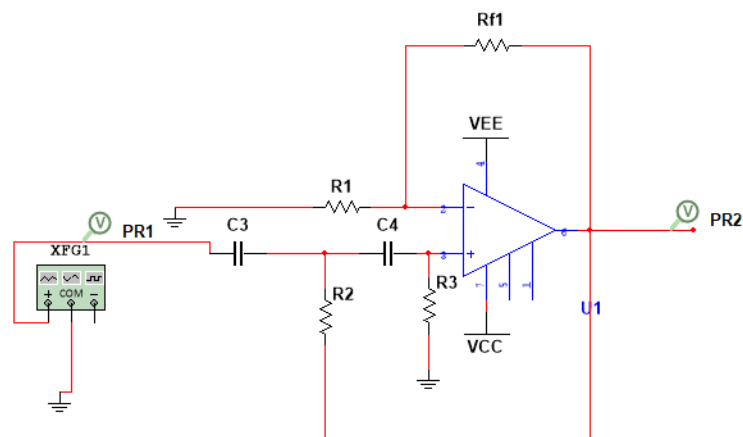

Fig 5.3: Second order Butterworth high pass filter

Design Specifications:

Cut-off frequency, $f_c = \text{_____}$

Design Procedure:

$$F_c = \frac{1}{2\pi RC}$$

Choose, $C = \text{_____}$,

$R = \text{_____}$

For second order Butterworth filter: $S_n^2 + 1.414S_n + 1$

$$\alpha = \underline{\hspace{2cm}}$$

$$\alpha = 3 - A_0$$

$$A_0 = \underline{\hspace{2cm}}$$

$$\underline{A}_0 = 1 + \frac{R_f}{R_1}$$

$$\frac{R_f}{R_1} = \underline{\hspace{2cm}}$$

$$R_f = \underline{\hspace{2cm}}$$

$$R_1 = \underline{\hspace{2cm}}$$

$$H_{LPF}(s) = \frac{1.586}{s_n^2 + 1.414s_n + 1}$$

Observations & Calculations:

Table 4.3: Frequency response of Second order Butterworth high pass filter $V_i = \underline{\hspace{2cm}}$

| Frequency (Hz) | V_0 (p-p) (V) | Gain ($\frac{V_o}{V_i}$) | $ A_v = 20\log\frac{V_o}{V_i}$ in dB |
|----------------|-----------------|----------------------------|---------------------------------------|
| | | | |
| | | | |
| | | | |
| | | | |
| | | | |
| | | | |
| | | | |
| | | | |
| | | | |
| | | | |
| | | | |
| | | | |
| | | | |
| | | | |
| | | | |
| | | | |
| | | | |
| | | | |
| | | | |
| | | | |

Third order Butterworth high pass filter

Circuit Diagram:

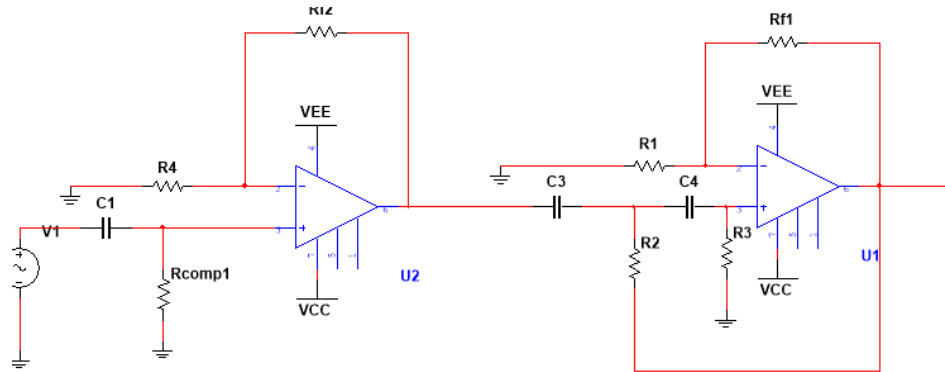

Fig 4.4: Third order Butterworth high pass filter

Design Specifications:

Cut-off frequency, $f_c = \underline{\hspace{2cm}}$

Design Procedure:

$$F_c = \frac{1}{2\pi RC}$$

Choose, $C = \underline{\hspace{2cm}}$

$R = \underline{\hspace{2cm}}$

For fourth order Butterworth filter:

$$(S_n^2 + 1)(S_n^2 + S_n + 1)$$

Total Gain = $\underline{\hspace{2cm}}$

Hence, for first order filter gain is $\underline{\hspace{2cm}}$

$A_0 = \underline{\hspace{2cm}}$

$$A_0 = 1 + \frac{Rf1}{R1}$$

$$\frac{Rf1}{R1} = \underline{\hspace{2cm}}$$

$Rf1 = \underline{\hspace{2cm}}$

$R1 = \underline{\hspace{2cm}}$

$$\alpha_2 = 1$$

$$\alpha = 3 - A_0$$

$$A_0 = \underline{\hspace{2cm}}$$

$$\underline{A_0} = 1 + \frac{Rf2}{R2}$$

$$\frac{Rf2}{R2} = \underline{\hspace{2cm}}$$

$$Rf2 = \underline{\hspace{2cm}}$$

$$R2 = \underline{\hspace{2cm}}$$

$$H_{LPF}(s) = \frac{5}{s_n + 1} \times \frac{2}{s_n^2 + s_n + 1}$$

Procedure:

1. Test the Op-Amp as ZCD.
2. Set up the circuits as shown in figure 4.1 to 4.4
3. Obtain the frequency response.
4. Compute the cut-off frequency, pass band gain and roll-off for each circuit and compare with the corresponding theoretical values.

Observations & Calculations:

Table 4.4: Frequency response of Third order Butterworth high pass filter $V_i = \underline{\hspace{2cm}}$

| Frequency (Hz) | V_0 (p-p) (V) | Gain ($\frac{V_o}{V_i}$) | $ A_v = 20\log\frac{V_o}{V_i}$ in dB |
|----------------|-----------------|----------------------------|---------------------------------------|
| | | | |
| | | | |
| | | | |
| | | | |
| | | | |
| | | | |
| | | | |
| | | | |
| | | | |
| | | | |
| | | | |
| | | | |
| | | | |
| | | | |
| | | | |
| | | | |
| | | | |
| | | | |
| | | | |
| | | | |
| | | | |

Comparison of practical and theoretical values of cut-off frequency, pass band gain and roll-off for high pass filter:

| SL.NO | Parameter | Second order | | Third order | |
|-------|-------------------|--------------|-----------|-------------|-----------|
| | | Theoretical | Practical | Theoretical | Practical |
| 1. | Pass band gain | | | | |
| 2. | Cut-off frequency | | | | |
| 3. | Roll-off | | | | |

Inference:

Advantages:

Disadvantages:

Applications:

Experiment – V

Design and testing of Narrow Band pass and Band elimination

Aim:

To design and test Narrow band pass and band elimination filters and

1. Obtain their Frequency response.
2. Find the cut-off frequencies and Bandwidth.
3. Find band pass gain.
4. Find the roll-off.

Components required:

| SL.NO | Components/Equipment's Required | Specifications | Quantity |
|-------|---------------------------------|-------------------|-------------|
| 1. | Op-amp | μ A741 | 1 |
| 2. | Resistors | As per the design | As required |
| 3. | Capacitors | As per the design | As required |
| 4. | DC regulated power supply | 0-15V | 1 |
| 5. | CRO | - | 1 |
| 6. | Signal generator | - | 1 |
| 7. | Breadboard | - | 1 |
| 8. | Connecting wires | - | As required |

Pre-requisites:

1. Operation of BPF and BEF.
2. Realization of BPF and BEF using LPF and HPF.
3. Difference between Narrow and Wide band pass filter.
4. Applications of BPF and BEF.

Second order Narrow Band pass filter

Circuit Diagram:

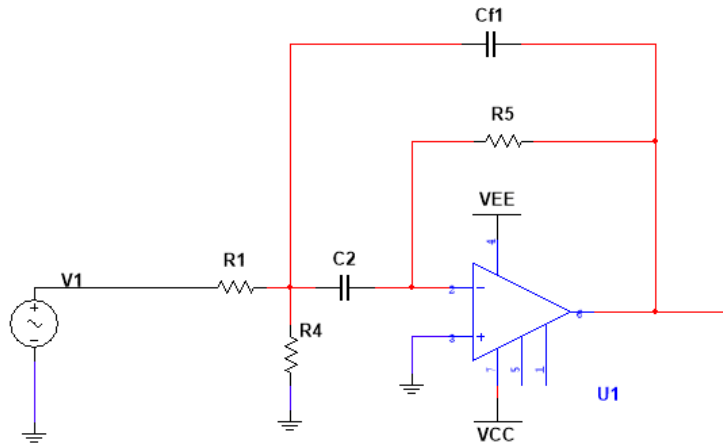

Fig 5.1: Second order Narrow band pass filter

Design Specifications:

Center frequency, $f_0 = \underline{\hspace{2cm}}$

Quality Factor, $Q_0 = \underline{\hspace{2cm}}$

Gain at resonance, $|A_0| = \underline{\hspace{2cm}}$

Design Procedure:

$$R_1 = \frac{Q_0}{\omega_0 C |A_0|} \text{ ----- 7.1}$$

Choose, $C = \underline{\hspace{2cm}}$

$$R_5 = \frac{2Q_0}{\omega_0 C} \text{ ----- 7.2}$$

$R_5 = \underline{\hspace{2cm}}$

$$R_4 = \frac{Q_0}{\omega_0 C [2Q_0 - |A_0|]} \text{ - 7.3}$$

Pass band gain, $A_0 = \underline{\hspace{2cm}}$

Calculate R_4 , Make sure that $2Q_0^2 > |A_0|$

$R_4 = \underline{\hspace{2cm}}$

Observations & Calculations:

Table 5.1: Frequency Response of the Narrow Band pass filter

$V_i =$ _____

| Frequency (Hz) | $V_{O(P-P)}$ (V) | Gain (V_o/V_i) | $ A_v = 20\log\frac{V_o}{V_i}$ in dB |
|----------------|------------------|--------------------|---------------------------------------|
| | | | |
| | | | |
| | | | |
| | | | |
| | | | |
| | | | |
| | | | |
| | | | |
| | | | |
| | | | |
| | | | |
| | | | |
| | | | |
| | | | |
| | | | |
| | | | |

Table 5.2: Comparison of practical and theoretical values for Narrow band pass filter

| SL.NO | Parameter | Theoretical | Practical |
|-------|--------------------------------|-------------|-----------|
| 1. | Gain at Resonance, $ A_0 $ | | |
| 2. | Center frequency, f_0 | | |
| 3. | Bandwidth, BW | | |
| 4. | Quality Factor, Q_0 | | |
| 5. | Lower cut-off frequency, f_L | | |
| 6. | Upper cut-off frequency, f_H | | |
| 7. | Roll-off | | |

Theoretical Equations in terms of circuit components:

$$Q_0 = \frac{\omega_0 C}{2 G_5}$$

$$BW = \frac{1}{\pi C R_5}$$

$$f_H = \frac{1}{2\pi C_1 R_1}$$

$$f_L = \frac{1}{2\pi C_2 R_2}$$

Narrow Band elimination filter (Notch filter)

Circuit Diagram:

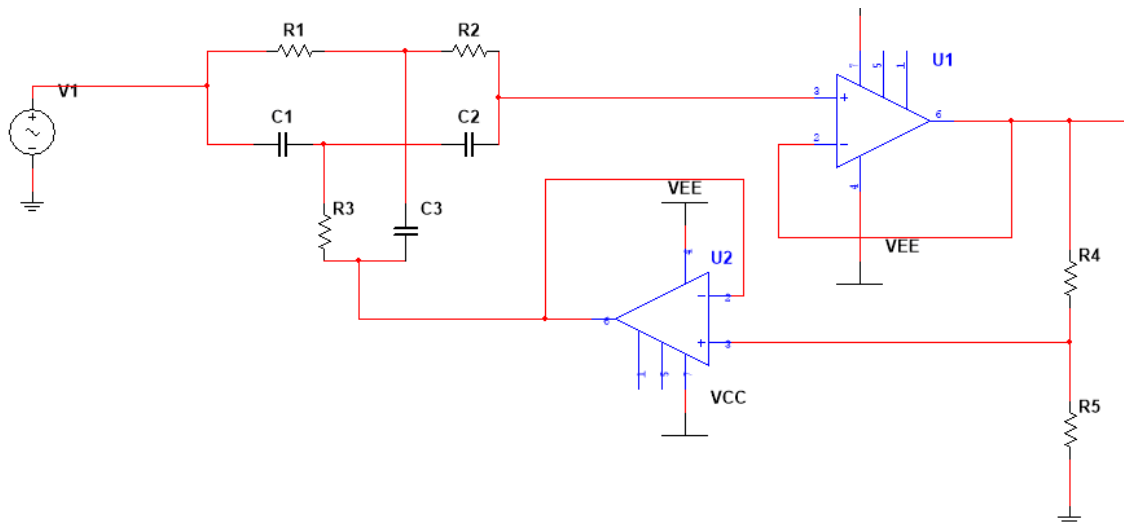

Fig 5.3: Narrow Band elimination filter (Notch filter)

Design Specifications:

Notch frequency, $f_N = \underline{\hspace{2cm}}$

Quality factor, $Q_0 = \underline{\hspace{2cm}}$

Design Procedure:

$$f_N = \frac{1}{2\pi RC}$$

Choose, C = _____

R = _____

$$Q_0 = \frac{1}{4(1-K)}$$

$$K = \frac{R_2}{R_1 + R_2}$$

Calculate R₁ and R₂

R₁ = _____

R₂ = _____

Procedure:

1. Test the Op-Amp as ZCD.
2. Setup the circuits as shown in figure 5.1 and 5.3
3. Obtain frequency response
4. Compute the frequencies ω_0 , ω_1 , ω_2 , Bandwidth, Quality factor and gain at resonance for each circuit and compare with the corresponding theoretical values.

Theoretical Equations in terms of circuit components:

$$Q_0 = \frac{1}{4(1-K)}$$

$$BW = 4(1-K)f_0$$

$$\omega_H = \omega_0 * [\sqrt{1 + 4(1 - k)^2} + 2(1-k)]$$

$$\omega_L = \omega_0 * [\sqrt{1 + 4(1 - k)^2} - 2(1-k)]$$

Inference:

Advantages:

Applications:

Experiment – VI

Design and testing of Inverting and Non-inverting Schmitt triggers

Aim:

To design and test Op-amp inverter and non-inverter, Schmitt trigger and

- i) Calculate the lower and upper trip point voltages.
- ii) Observe transfer characteristics and calculate the hysteresis.

Components required:

| SL.NO | Components/Equipment's Required | Specifications | Quantity |
|-------|---------------------------------|-------------------|-------------|
| 1. | Op-amp | μ A741 | 1 |
| 2. | Resistors | As per the design | As required |
| 3. | Zener Diode | 1N4733A | 2 |
| 4. | DC regulated power supply | 0-15V | 1 |
| 5. | CRO | - | 1 |
| 6. | Signal generator | - | 1 |
| 7. | Breadboard | - | 1 |
| 8. | Connecting wires | - | As required |

Pre-requisites:

1. Op-amp as comparator.
2. Problems with basic comparator.
3. Operation of inverting and non-inverting Schmitt triggers with relevant design equations.
4. Amplitude limiter in Schmitt trigger.
5. Applications of comparator circuit and Schmitt trigger.

Inverting Schmitt trigger

Circuit Diagram:

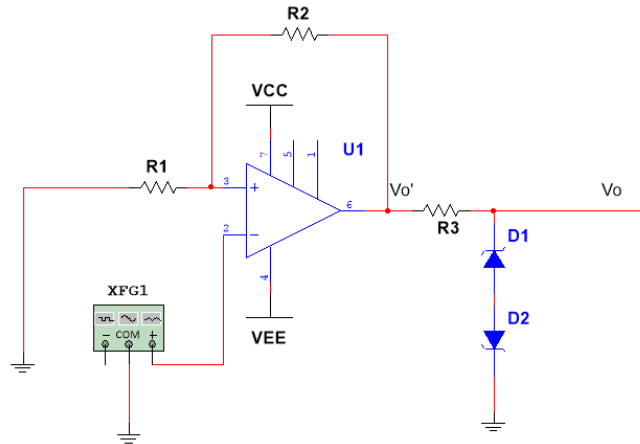

Fig 6.1: Inverting Schmitt trigger

Design Specifications:

$$V_{UTP} = \underline{\hspace{2cm}}$$

$$V_{LTP} = \underline{\hspace{2cm}}$$

Design Procedure:

$$V_{UTP} = \frac{V_R R_2}{R_1 + R_2} + \frac{V_{sat} R_1}{R_1 + R_2} \text{ ----- 7.1}$$

$$V_{LTP} = \frac{V_R R_2}{R_1 + R_2} - \frac{V_{sat} R_1}{R_1 + R_2} \text{ ----- 7.2}$$

$$V_H = \frac{2 V_{sat} R_1}{R_1 + R_2} \text{ ----- 7.3}$$

Using the given specifications, design the values of V_R , R_1 and R_2 .

$$R_1 = \underline{\hspace{2cm}}$$

$$R_1 = \underline{\hspace{2cm}}$$

$$V_R = \underline{\hspace{2cm}}$$

Amplitude limiting circuit:

Design amplitude limiter circuit for $V_0 = \underline{\hspace{2cm}}$

Procedure:

1. Test the Op-Amp as ZCD.
2. Setup the circuits as shown in Fig. 6.1 and 6.4.
3. Apply the sinusoidal input of frequency 1KHz and peak value, $V_m > \max \{ |V_{UTP}|, |V_{LTP}| \}$
4. The output waveform on CRO is observed, measure V_{UTP} V_{LTP} and V_H .
5. plot the transfer characteristics. Measure V_{UTP} V_{LTP} and V_H on transfer characteristics and cross check.
6. Repeat steps 3-5 with $V_R = 0$.
7. Also observe output waveform and input waveform with transistor.

Comparison of practical and theoretical values ($V_R \neq 0$)

| SL.NO | Quantity | Inverting Schmitt trigger | |
|-------|-----------|---------------------------|-----------|
| | | Theoretical | Practical |
| 1. | V_{UTP} | | |
| 2. | V_{LTP} | | |
| 3. | V_H | | |
| 4. | V_0 | | |
| 5. | V_0' | | |

Comparison of practical and theoretical values ($V_R = 0$)

| SL.NO | Quantity | Inverting Schmitt trigger | |
|-------|-----------|---------------------------|-----------|
| | | Theoretical | Practical |
| 1. | V_{UTP} | | |
| 2. | V_{LTP} | | |
| 3. | V_H | | |
| 4. | V_0 | | |
| 5. | V_0' | | |

Observed output waveforms and transfer characteristics for inverting Schmitt trigger ($V_R \neq 0$)

Observed output waveforms and transfer characteristics for inverting Schmitt trigger ($V_R = 0$)

Observed output waveforms and transfer characteristics for inverting Schmitt trigger with triangular waveform ($V_R \neq 0$)

Observed output waveforms and transfer characteristics for inverting Schmitt trigger with triangular waveform ($V_R = 0$)

Non-Inverting Schmitt trigger

Circuit Design:

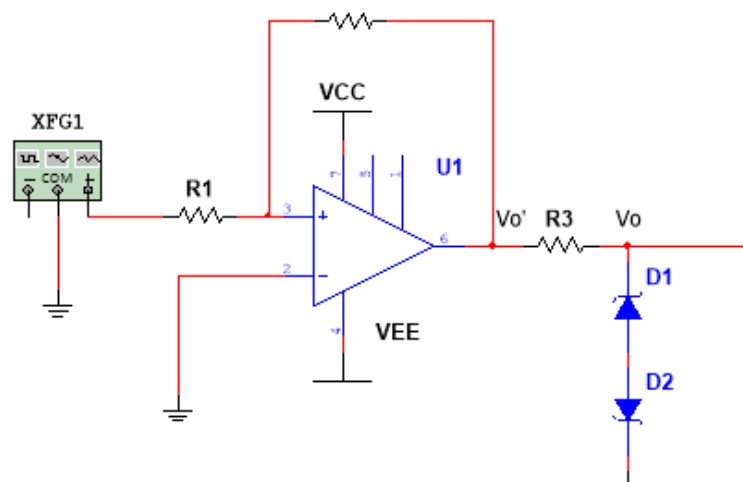

Fig 6.4: Non-inverting Schmitt trigger

Design Specifications:

$$V_{UTP} = \underline{\hspace{2cm}}$$

$$V_{LTP} = \underline{\hspace{2cm}}$$

Design Procedure:

$$V_{UTP} = \frac{V_R R_1 + R_2}{R_2} + \frac{V_{sat} R_1}{R_2} \text{ ----- 7.4}$$

$$V_{LTP} = \frac{V_R R_1 + R_2}{R_2} - \frac{V_{sat} R_1}{R_2} \text{ ----- 7.5}$$

$$V_H = \frac{2 V_{sat} R_1}{R_2} \text{ ----- 7.6}$$

Using the given specifications, design the values of V_R , R_1 and R_2 .

$R_1 =$ _____

$R_2 =$ _____

$V_R =$ _____

Amplitude limiting circuit:

Design amplitude limiter circuit for $V_0 =$

Comparison of practical and theoretical values ($V_R \neq 0$)

| SL.NO | Quantity | Non-Inverting Schmitt trigger | |
|-------|-----------|-------------------------------|-----------|
| | | Theoretical | Practical |
| 1. | V_{UTP} | | |
| 2. | V_{LTP} | | |
| 3. | V_H | | |
| 4. | V_0 | | |
| 5. | V_0' | | |

Comparison of practical and theoretical values ($V_R = 0$)

| SL.NO | Quantity | Non-Inverting Schmitt trigger | |
|-------|-----------|-------------------------------|-----------|
| | | Theoretical | Practical |
| 1. | V_{UTP} | | |
| 2. | V_{LTP} | | |
| 3. | V_H | | |
| 4. | V_0 | | |
| 5. | V_0' | | |

Observed output waveforms and transfer characteristics for Non-inverting Schmitt trigger ($V_R \neq 0$)

Observed output waveforms and transfer characteristics for Non-inverting Schmitt trigger ($V_R = 0$)

Observed output waveforms and transfer characteristics for Non-inverting Schmitt trigger with triangular waveform ($V_R \neq 0$)

Observed output waveforms and transfer characteristics for Non-inverting Schmitt trigger with triangular waveform ($V_R = 0$)

Inference:

Advantages:

Applications:

Experiment – VII

Design and testing of Op-Amp Square wave and Triangular Wave generator

Aim:

To design and test Op-amp square wave and triangular wave generator and

- i) Study variable Duty cycle operation at a constant frequency.
- ii) Study Variable frequency operation at a duty cycle.

Components Required:

| SL.NO | Components/Equipment's Required | Specifications | Quantity |
|-------|---------------------------------|-------------------|-------------|
| 1. | Op-amp | μ A741 | 1 |
| 2. | Resistors | As per the design | As required |
| 3. | Capacitors | As per the design | As required |
| 4. | DC regulated power supply | 0-15V | 1 |
| 5. | CRO | - | 1 |
| 6. | Signal generator | - | 1 |
| 7. | Breadboard | - | 1 |
| 8. | Connecting wires | - | As required |
| 9. | Diode | 1N3909 | 2 |

Pre-requisites:

1. Astable and Monostable multivibrators.
2. Operation of square wave generator.
3. Operation of triangular wave generator.
4. Variable duty cycle and variable frequency operation of square wave and triangular wave generators.

Circuit Diagram:

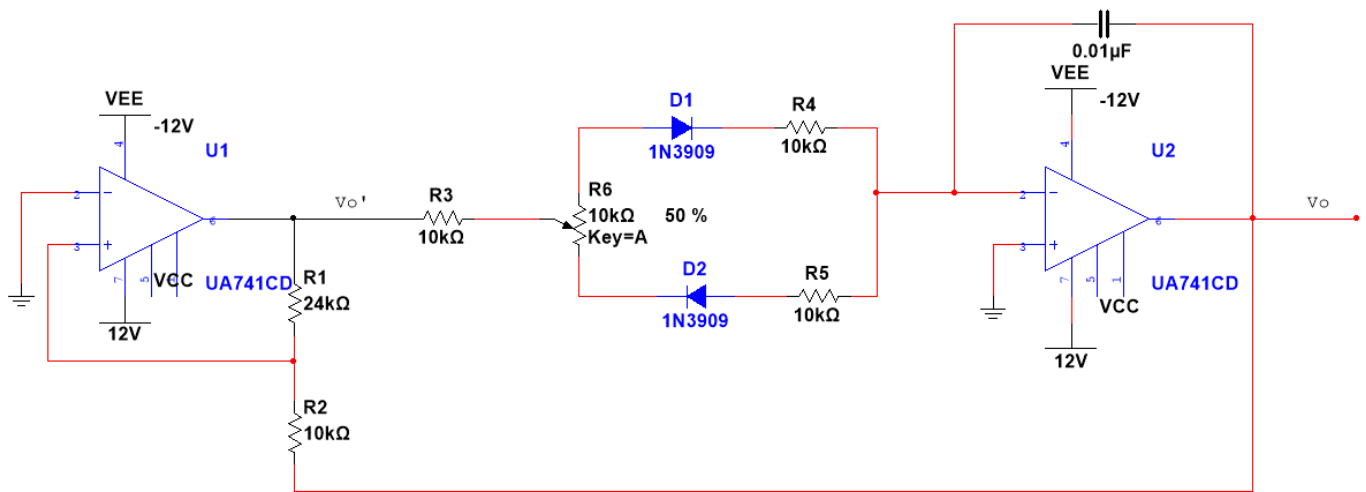

Fig 7.1: Op-Amp Square wave and triangular wave generator

Design Specifications:

Peak-to-peak value of triangular waveform : _____

Frequency Range : 200Hz to 2000Hz

Duty Cycle : 20% to 80%

$\pm V_{cc}$: $\pm 12V$

Design Procedure:

$$T_{ON} = (R_6 + R_{5a} + R_3)C \quad \text{-----} \quad 7.1$$

$$T_{OFF} = (R_6 + R_{5b} + R_3)C \quad \text{-----} \quad 7.2$$

$$T = (2R_6 + R_5 + 2R_3)C \quad \text{-----} \quad 7.3$$

$$D = \frac{T_{on}}{T} = \frac{R_6 + R_{5a} + R_3}{2R_6 + R_5 + 2R_3} \quad \text{-----} \quad 7.4$$

$$V_{0(p-p)} = \frac{2V_{sat}R_1}{R_2} \quad \text{-----} \quad 7.5$$

Using equations (7.1) to (7.5), design the component values for the given specifications.

Let $V_{0(p-p)} =$ _____

$V_{sat} =$ _____

Using equation 7.5,

$$R_1 = \underline{\hspace{2cm}} \quad ; \quad R_2 = \underline{\hspace{2cm}}$$

Let $f = 2\text{kHz}$, $T = 0.5\text{ms}$, $C = 0.01\mu\text{F}$

Using equation 8.3,

$$R_5 = \underline{\hspace{2cm}}$$

$$R_6 = \underline{\hspace{2cm}}$$

$$R_3 = \underline{\hspace{2cm}}$$

Expected waveforms of V_o and V_o' :

Fig 7.2: Expected Waveforms of V_o' and V_o
(Drawn on same time scale)

Procedure:

1. Setup the circuit as shown in Figure 7.1.
2. Set $R_6 = 0$, keep $R_{5a} = R_{5b} = R_5/2$
3. Observe the waveforms of V_o' and V_o . Measure frequency and duty cycle.
4. Vary R_5 to adjust duty cycle and record observations in Table 7.1.
5. Study variable frequency operation by adjusting R_6 and record observations in Table 7.2 to 7.4.

Observations & Calculations:

Table 7.1: Variable duty cycle operation ($R_6 = 0$)

| SL.N O | R_5 | D | | f | | $V_{o'}'_{(p-p)}$ | | $V_{o(p-p)}$ | |
|-----------|-------------------|-----------------|---------------|-----------------|---------------|-------------------|---------------|-----------------|---------------|
| | | Theoretic al | Practica l | Theoretica l | Practica l | Theoretica l | Practica l | Theoretic al | Practica l |
| 1. | $R_{5a} = 0$ | | | | | | | | |
| 2. | $R_{5a} = R_5/4$ | | | | | | | | |
| 3. | $R_{5a} = R_5/2$ | | | | | | | | |
| 4. | $R_{5a} = 3R_5/4$ | | | | | | | | |
| 5. | $R_{5a} = R_5$ | | | | | | | | |

Table 7.2: Variable duty cycle operation ($R_{5a} = R_5/2$)

| SL.N O | R_6 | D | | f | | $V_{o'}'_{(p-p)} (V)$ | | $V_{o(p-p)} (V)$ | |
|-----------|----------------|-----------------|---------------|-----------------|---------------|-----------------------|---------------|------------------|---------------|
| | | Theoretic al | Practica l | Theoretica l | Practica l | Theoretica l | Practica l | Theoretic al | Practica l |
| 1. | $R_6 = 0$ | | | | | | | | |
| 2. | $R_6 = R_6/4$ | | | | | | | | |
| 3. | $R_6 = R_6/2$ | | | | | | | | |
| 4. | $R_6 = 3R_6/4$ | | | | | | | | |
| 5. | $R_6 = R_6$ | | | | | | | | |

Waveforms for $V_{o'}$ and V_o for the observations in 7.1:

Waveforms for V_o' and V_o for the observations in 7.2:

Inference:

Advantages:

Applications:

Experiment – VIII

Design and testing of Astable Multi-vibrator using 555 Timer.

Aim:

To design Astable Multi-vibrator using 555 Timer and

- iii) Study variable Duty cycle operation.
- iv) Study Variable frequency operation.

Components Required:

| SL.NO | Components/Equipment's Required | Specifications | Quantity |
|-------|---------------------------------|-------------------|-------------|
| 1. | Timer | 555 | 1 |
| 2. | Resistors | As per the design | As required |
| 3. | Capacitors | As per the design | As required |
| 4. | DC regulated power supply | 0-15V | 1 |
| 5. | CRO | - | 1 |
| 6. | Signal generator | - | 1 |
| 7. | Breadboard | - | 1 |
| 8. | Connecting wires | - | As required |
| 9. | Diode | 1N3909 | 2 |
| 10. | Zener Diode | 1N4733A | 1 |
| 11. | Potentiometer | 12.025k Ω | 1 |

Pre-requisites:

1. Functional block of 555 timer.
2. Operation of 555 timer as Astable Multivibrator.
3. Variable frequency and Duty cycle operation.

Circuit Diagram:

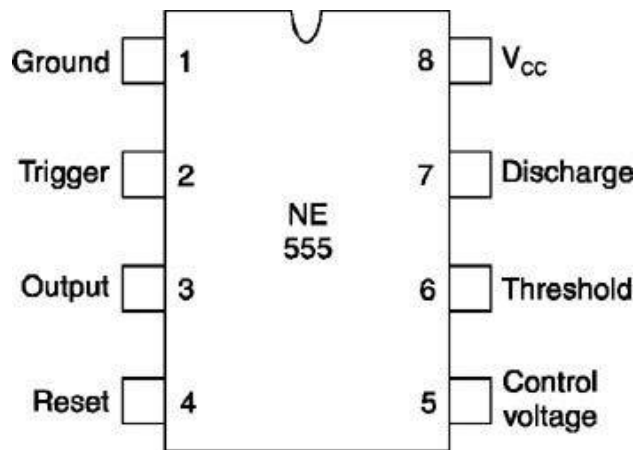

Fig 8.1: Pin Diagram of 555 timer.

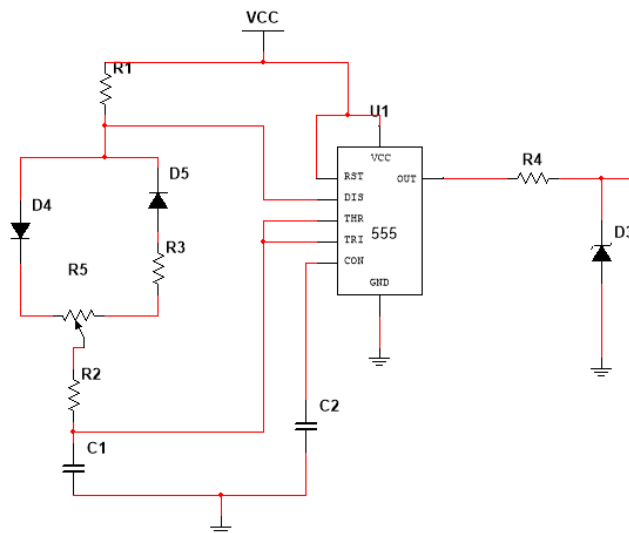

Fig 8.2: Astable Multivibrator using 555 timer.

1 . Design Specifications:

| | |
|------------------|-------------------|
| Output Amplitude | : _____ |
| Frequency Range | : 500Hz to 5000Hz |
| Duty Cycle | : 20% to 80% |
| $\pm V_{cc}$ | : $\pm 12V$ |

Design Equations:

$T_{ON} = (R_1 + R_{3a} + R_4)C$ -----8.1

$T_{OFF} = (R_1 + R_{3b} + R_4)C$ -----8.2

$T = (2R_1 + R_3 + 2R_4)C$ -----8.3

$$D = \frac{T_{on}}{T} = \frac{R_1 + R_{3a} + R_4}{2R_1 + R_3 + 2R_4} \quad \text{-----8.4}$$

Design Procedure:

Calculate the values of R_1 , R_3 , R_4 and C using the given specifications. Also design the limiting circuit.

Using equation 8.1,

$$R_1 = \underline{\hspace{2cm}}$$

$$R_4 = \underline{\hspace{2cm}}$$

Let $f = 2\text{kHz}$, $T = 0.5\text{ms}$, $C = 0.01\mu\text{F}$

$$R_3 = \underline{\hspace{2cm}}$$

Expected waveforms of V_o , V_o' , V_C :

Procedure:

1. Setup the circuit as shown in Figure 8.2.
2. Set $R_4 = 0$, keep $R_{3a} = R_{3b} = R_3/2$.
3. Observe the waveforms of V_o , V_o' and V_C . Measure frequency and duty cycle.
4. Vary R_5 to adjust duty cycle and record observations in Table 8.1.
5. Study variable frequency operation by adjusting R_6 and record observations in Table 8.2.

Table 8.1: Variable duty cycle operation ($R_4 = 0$)

| SL.N O | R_5 | D | | f | | $V_{o'(p-p)}$ (V) | | $V_{o(p-p)}$ (V) | |
|-----------|-------------------|-----------------|---------------|-----------------|---------------|-------------------|---------------|------------------|---------------|
| | | Theoretic al | Practica l | Theoretica l | Practica l | Theoretica l | Practica l | Theoretic al | Practica l |
| 1. | $R_{3a} = 0$ | | | | | | | | |
| 2. | $R_{3a} = R_3/4$ | | | | | | | | |
| 3. | $R_{3a} = R_3/2$ | | | | | | | | |
| 4. | $R_{3a} = 3R_3/4$ | | | | | | | | |
| 5. | $R_{3a} = R_3$ | | | | | | | | |

Table 8.2: Variable frequency operation ($R_{3a} = R_3/2$)

| SL.N O | R_4 | D | | f | | $V_{o'(p-p)}$ (V) | | $V_{o(p-p)}$ (V) | |
|-----------|----------------|-----------------|---------------|-----------------|---------------|-------------------|---------------|------------------|---------------|
| | | Theoretic al | Practica l | Theoretica l | Practica l | Theoretica l | Practica l | Theoretic al | Practica l |
| 1. | $R_4 = 0$ | | | | | | | | |
| 2. | $R_4 = R_4/4$ | | | | | | | | |
| 3. | $R_4 = R_4/2$ | | | | | | | | |
| 4. | $R_4 = 3R_4/4$ | | | | | | | | |
| 5. | $R_4 = R_4$ | | | | | | | | |

Table 8.3: Variable duty cycle operation ($R_4 = 0$)

| SL.N O | R_5 | $V_{C(p-p)}$ (V) | |
|-----------|-------------------|------------------|---------------|
| | | Theoretic al | Practica l |
| 1. | $R_{3a} = 0$ | | |
| 2. | $R_{3a} = R_3/4$ | | |
| 3. | $R_{3a} = R_3/2$ | | |
| 4. | $R_{3a} = 3R_3/4$ | | |
| 5. | $R_{3a} = R_3$ | | |

Table 8.4: Variable frequency operation ($R_{3a} = R_3/2$)

| SL.N O | R_4 | $V_{C(p-p)}$ (V) | |
|-----------|----------------|------------------|---------------|
| | | Theoretic al | Practica l |
| 1. | $R_4 = 0$ | | |
| 2. | $R_4 = R_4/4$ | | |
| 3. | $R_4 = R_4/2$ | | |
| 4. | $R_4 = 3R_4/4$ | | |
| 5. | $R_4 = R_4$ | | |

Waveforms for V_o' , V_o and V_C for the observations in 8.1 & 8.3:

Waveforms for V_o' , V_o and V_C for the observations in 8.2 & 8.4:

Inference:

Advantages:

Disadvantages:

Applications:

Experiment – IX

Design and testing of Voltage Regulator using 723

Aim:

1. To design low voltage regulator using 723 and obtain load & line regulations.
2. To design high voltage regulator using 723 and obtain load & line regulations.

Components Required:

| SL.NO | Components/Equipment's Required | Specifications | Quantity |
|-------|---------------------------------|-------------------|-------------|
| 1. | Voltage Regulator IC | IC 723 | 1 |
| 2. | Resistors | As per the design | As required |
| 3. | Capacitors | As per the design | As required |
| 4. | DC regulated power supply | 0-15V | 1 |
| 5. | CRO | - | 1 |
| 6. | Signal generator | - | 1 |
| 7. | Breadboard | - | 1 |
| 8. | Connecting wires | - | As required |
| 9. | Decade resistance box | - | 1 |

Pre-requisites:

4. Need for voltage regulator, load and line regulations.
5. Functional Block diagram of 723.
6. Low and high voltage regulators using 723.
7. Current limiting, current boosting, fold back current limiting.

Low Voltage Regulator

Circuit Diagram:

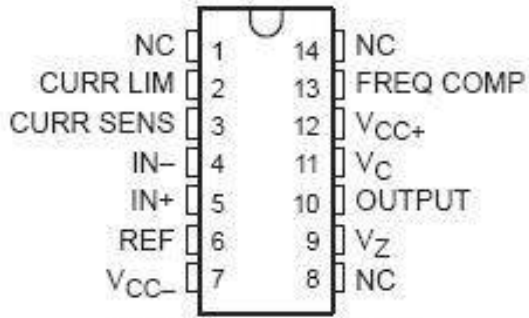

Fig 9.1: Pin Diagram of IC 723.

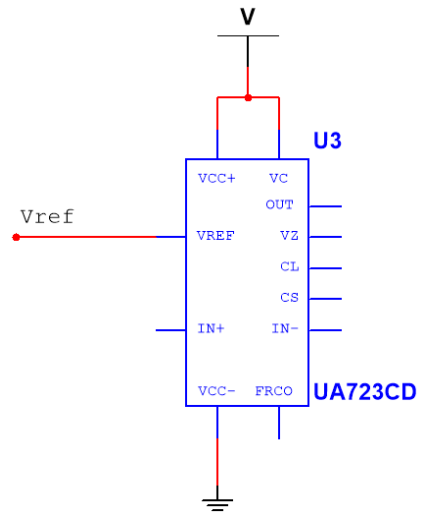

Fig 9.2: Circuit Connection for testing IC 723.

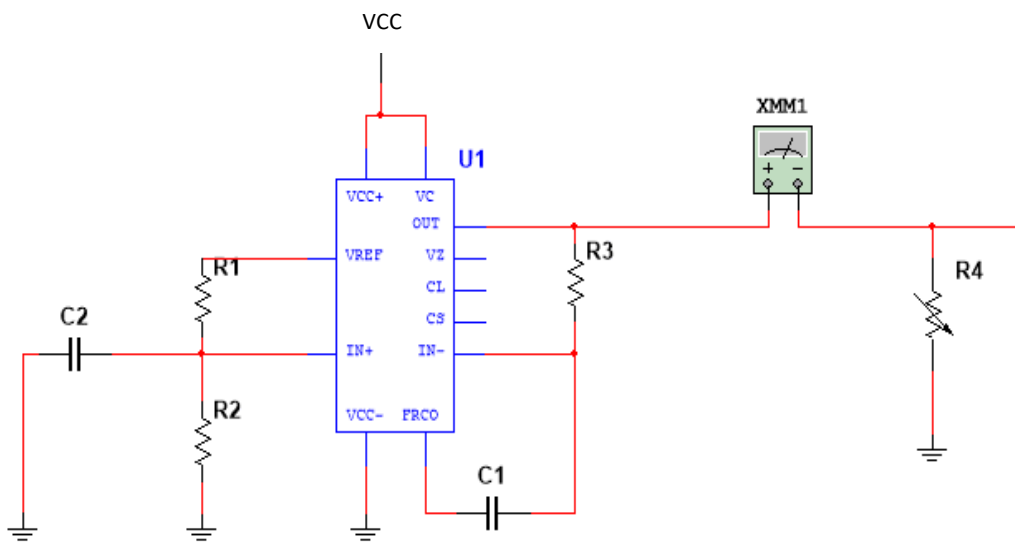

Fig 9.3: Low voltage Regulator using IC 723.

Design Specifications:

$$V_O = 15V$$

$$I_L = 100mA$$

$$V_{in} = 10V \pm 20\%$$

Design Procedure:

$$V_0 = V_{\text{ref}} \left[\frac{R_2}{R_1 + R_2} \right]$$

$$V_{\text{ref}} = \underline{\hspace{2cm}}$$

Assume R_1 and calculate R_2 .

$$R_1 = \underline{\hspace{2cm}}$$

$$R_2 = \underline{\hspace{2cm}}$$

$$R_3 = R_1 || R_2$$

$$R_3 = \underline{\hspace{2cm}}$$

$$R_{L(\text{min})} = \left[\frac{V_0}{I_{L(\text{max})}} \right]$$
$$= \left[\frac{5V}{100mA} \right]$$

$$= \underline{\hspace{2cm}}$$

Procedure:

1. Setup the circuit as shown in Figure 9.2. Apply DC voltage, $V = 10V (> V_{\text{ref}})$. Check voltage at pin 6. A voltage of 7.15V at this pin ensures that 723IC is intact.
2. Now connect the circuit as shown in Figure 9.3. Set the DC voltage V_{in} at 10V ($> V_{\text{ref}}$) and adjust the R_L at 1K Ω . Measure I_L & V_0 .
3. Vary R_L in suitable steps from 1k Ω to 50 Ω ($R_{L(\text{min})}$). At each step note down I_L and V_0 . Record observations in Table 9.1.
4. Set R_L for $I_{L(\text{MAX})}$, $\frac{1}{2} I_{L(\text{MAX})}$ and $\frac{1}{4} I_{L(\text{MAX})}$, and at each step note down the corresponding V_0 .
5. Now set R_L such that $I_L = \frac{1}{2} I_{L(\text{MAX})}$, with V_{in} unaltered at 10V. Then by varying V_{in} from 8V to 12V in suitable steps note down V_{in} and V_0 . Record observations in Table 9.2.
6. Now connect the circuit as shown in Figure 9.3. Set the DC voltage V_{in} at 20V ($> V_0$) and adjust the R_L at 1K Ω . Measure I_L and V_0 .
7. Repeat steps 3,4 and 5 and record observations in Table 9.3 and 9.4

Table 9.1: Load Regulation for low voltage regulator.

| SL.NO | R _L (Ω) | I _L (mA) | V _O (V) |
|-------|--------------------|---------------------|--------------------|
| 1. | | | |
| 2. | | | |
| 3. | | | |
| 4. | | | |
| 5. | | | |
| 6. | | | |
| 7. | | | |
| 8. | | | |
| 9. | | | |
| 10. | | | |
| 11. | | | |

$$\% \text{ load regulation} = \left[\frac{V_{NL} - V_{Load}}{V_{Load}} \right] \times 100.$$

$$V_{NL} = V_o \text{ when } R_L = \infty \text{ (} I_L = 0 \text{)}.$$

$$V_{Load} = V_O \text{ when } I_L = I_{L(MAX)} \text{ or } \frac{1}{2} I_{L(MAX)} \text{ or } \frac{1}{4} I_{L(MAX)}.$$

Calculate load regulation at each of these loads.

Calculation of % load regulation:

Table 9.2: Line Regulation for low voltage regulator.

| SL.NO | V _{in} (V) | V _o (V) |
|-------|---------------------|--------------------|
| 1. | | |
| 2. | | |
| 3. | | |
| 4. | | |
| 5. | | |
| 6. | | |
| 7. | | |
| 8. | | |
| 9. | | |

$$\% \text{ line regulation} = \left[\frac{\Delta V_o}{\Delta V_{in}} \right] \times 100.$$

Calculate line regulation for 3 sets of ΔV_o and ΔV_{in} .

High Voltage Regulator

Circuit Diagram:

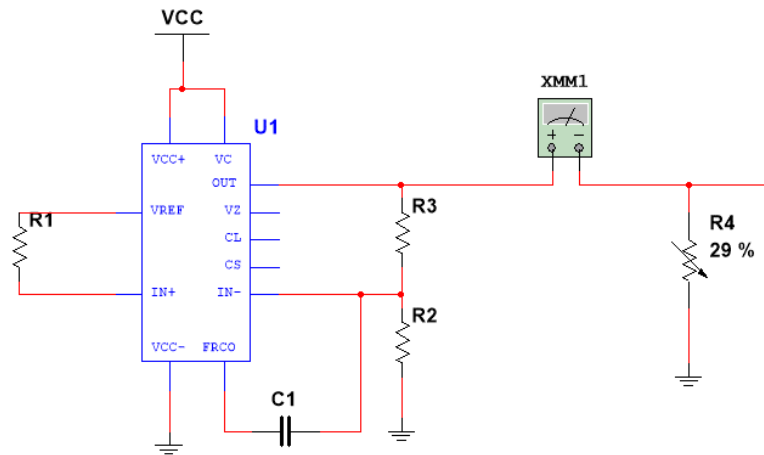

Fig 9.3: High Voltage Regulator using IC723.

Design Specifications:

$$V_O = 15V$$

$$I_L = 100mA$$

$$V_{in} = 20V \pm 20\%$$

Design Procedure:

$$V_O = V_{ref} \left[1 + \frac{R_1}{R_2} \right]$$

$$V_{ref} = \underline{\hspace{2cm}}$$

Assume R_1 and calculate R_2 .

$$R_1 = \underline{\hspace{2cm}}$$

$$R_2 = \underline{\hspace{2cm}}$$

$$R_3 = R_1 || R_2$$

$$R_3 = \underline{\hspace{2cm}}$$

$$R_{L(min)} = \left[\frac{V_O}{I_{L(max)}} \right]$$

$$= \left[\frac{15V}{100mA} \right]$$

$$= \underline{\hspace{2cm}}$$

Table 9.3: Load Regulation for high voltage regulator.

| SL.NO | $R_L(\Omega)$ | $I_L(\text{mA})$ | $V_O(\text{V})$ |
|-------|---------------|------------------|-----------------|
| 1. | | | |
| 2. | | | |
| 3. | | | |
| 4. | | | |
| 5. | | | |
| 6. | | | |
| 7. | | | |
| 8. | | | |
| 9. | | | |
| 10. | | | |

$$\% \text{ load regulation} = \left[\frac{V_{NL} - V_{Load}}{V_{Load}} \right] \times 100.$$

$$V_{NL} = V_o \text{ when } R_L = \infty (I_L = 0).$$

$$V_{Load} = V_O \text{ when } I_L = I_{L(\text{MAX})} \text{ or } \frac{1}{2} I_{L(\text{MAX})} \text{ or } \frac{1}{4} I_{L(\text{MAX})}.$$

Calculate load regulation at each of these loads.

Calculation of % load regulation:

Table 9.4: Line Regulation for low voltage regulator.

| SL.NO | V _{in} (V) | V _o (V) |
|-------|---------------------|--------------------|
| 1. | | |
| 2. | | |
| 3. | | |
| 4. | | |
| 5. | | |
| 6. | | |
| 7. | | |
| 8. | | |
| 9. | | |

$$\% \text{ line regulation} = \left[\frac{\Delta V_o}{\Delta V_{in}} \right] \times 100.$$

Calculate line regulation for 3 sets of ΔV_o and ΔV_{in} .

Inference:

Advantages:

Disadvantages:

Applications:

WIRELESS COMMUNICATION

EDITED BY

S.LILLYPET



978-93-6255-103-0

WIRELESS COMMUNICATION

COPYRIGHT @ 2023 BY S.LILLYPET

ALL RIGHTS RESERVED. NO PART OF THIS BOOK MAY BE REPRODUCED OR TRANSMITTED IN ANY FORM OR BY ANY MEANS WITHOUT WRITTEN PERMISSION FROM THE AUTHOR.

ISBN: 978-93-6255-103-0

PUBLISHER: Ponnaiyah Ramajayam Institute of Science and Technology (PRIST)

TABLE OF CONTENTS

| CHAPTER | CONTENT | PAGE |
|----------------|---|-------------|
| | INTRODUCTION | 5 |
| 1 | FUNDAMENTALS OF WIRELESS COMMUNICATION Dr. S.DEVI | 18 |
| 2 | MODULATION TECHNIQUES Dr.S.AUDITHAN | 35 |
| 3 | WIRELESS COMMUNICATION SYSTEMS D.HARIKRISHNAN | 56 |
| 4 | WIRELESS NETWORK ARCHITECTURES T.DIVYA MANOHARI | 70 |
| 5 | ADVANCED WIRELESS TECHNOLOGIES A.AARTHI | 85 |
| | REFERENCES | 115 |

CHAPTER 1 FUNDAMENTALS OF WIRELESS COMMUNICATION

Dr.S.DEVI

Professor, Department of ECE

Ponnaiyah Ramajayam Institute of Science and Technology, Tamil Nadu, India.

Wireless communication involves transmitting information over distances without wired connections. Here's a concise overview of its fundamental concepts:

1. Basic Concepts

- **Signal Transmission:** Utilizes electromagnetic waves generated by a transmitter and detected by a receiver to convey information.
- **Frequency:** Determines the wavelength and propagation characteristics of a signal. Common bands include radio frequencies (RF), microwave, and millimeter waves.
- **Modulation:** Alters a carrier wave to transmit information. Common techniques are Amplitude Modulation (AM), Frequency Modulation (FM), and Phase Modulation (PM).

2. Communication Models

- **Analog vs. Digital:** Analog signals are continuous, while digital signals are discrete (binary code). Digital is preferred for efficiency and noise resistance.
- **Cellular Networks:** Divide regions into cells, each served by a base station. This design allows frequency reuse and efficient spectrum management.
- **Spread Spectrum:** Spreads the signal over a wider bandwidth to enhance security and reduce interference. Types include Frequency Hopping Spread Spectrum (FHSS) and Direct Sequence Spread Spectrum (DSSS).

3. Key Components

- **Transmitter:** Converts information into a suitable signal for transmission, including a modulator, oscillator, and amplifier.
- **Receiver:** Detects and converts the signal back into information, including a demodulator, filter, and amplifier.
- **Antennas:** Convert electrical signals into electromagnetic waves and vice versa, affecting range, directionality, and signal quality.

4. Propagation and Channels

- **Propagation:** The way radio waves travel, influenced by free-space loss, reflection, diffraction, and scattering. Proper understanding is vital for effective system design.
- **Channels:** Mediums through which signals travel, impacted by noise and interference. Key parameters include bandwidth and signal-to-noise ratio (SNR).

CHAPTER 2 MODULATION TECHNIQUES

Dr.S.AUDITHAN

Associate Professor, Department of ECE

Ponnaiyah Ramajayam Institute of Science and Technology, Tamil Nadu, India.

Modulation is a key technique in communication systems that encodes information onto a carrier signal, enabling data transmission over various channels. Here's a concise overview of essential modulation techniques:

1. Amplitude Modulation (AM)

- **Principle:** Alters the amplitude (signal strength) of the carrier wave in proportion to the information signal.
- **Characteristics:** Simple to implement but susceptible to noise and interference affecting amplitude.
- **Applications:** AM radio broadcasting, some two-way radios.

2. Frequency Modulation (FM)

- **Principle:** Changes the frequency of the carrier wave according to the information signal while keeping the amplitude constant.
- **Characteristics:** More resistant to noise compared to AM; provides superior sound quality.
- **Applications:** FM radio broadcasting, television sound, some two-way radios.

3. Phase Modulation (PM)

- **Principle:** Modifies the phase of the carrier wave in response to the information signal, with amplitude and frequency unchanged.
- **Characteristics:** Similar noise resilience to FM; encodes information through phase changes.
- **Applications:** Digital signal processing, certain radio communications.

4. Quadrature Amplitude Modulation (QAM)

- **Principle:** Combines amplitude modulation of two carrier waves (in-phase and quadrature) to transmit two signals simultaneously.
- **Characteristics:** Facilitates higher data rates using both amplitude and phase variations.
- **Applications:** Digital TV, cable modems, high-speed data communications.

5. Frequency Shift Keying (FSK)

- **Principle:** Represents digital data by shifting the carrier signal's frequency to denote different data values (e.g., binary 0 and 1).
- **Characteristics:** Simple and robust against noise; variants include Binary FSK (BFSK) and Gaussian FSK (GFSK).
- **Applications:** Modems, telemetry systems.

CHAPTER 3 WIRELESS COMMUNICATION SYSTEMS

D.HARIKRISHNAN

Assistant Professor, Department of ECE

Ponnaiyah Ramajayam Institute of Science and Technology, Tamil Nadu, India.

Wireless communication systems are vital for modern connectivity, utilizing various technologies to transmit and receive data without physical connections. Here's an overview of their key components, types, challenges, and emerging technologies:

1. Components of Wireless Communication Systems

- **Transmitter:** Converts information into a signal for transmission, using a modulator, oscillator, and amplifier to generate and prepare the carrier signal.
- **Receiver:** Detects and decodes the transmitted signal back into its original form, consisting of a demodulator, filter, and amplifier.
- **Antennas:** Convert electrical signals into electromagnetic waves and vice versa, affecting the signal's range, directionality, and quality.
- **Channel:** The medium through which signals travel, influenced by factors like noise, interference, and environmental conditions.

2. Types of Wireless Communication Systems

- **Cellular Networks:**
 - **Structure:** Uses cells served by base stations for efficient frequency reuse and spectrum management.
 - **Generations:** Ranges from 1G (analog) to 5G (high-speed, low-latency), with each generation offering enhanced features.
 - **Applications:** Mobile phones, data services, and IoT devices.
- **Wi-Fi:**
 - **Technology:** Operates mainly in 2.4 GHz and 5 GHz bands for local area network (LAN) connectivity.
 - **Standards:** Includes 802.11n, 802.11ac, and 802.11ax (Wi-Fi 6) for improved capacity.
 - **Applications:** Internet access in homes, offices, and public areas.
- **Bluetooth:**
 - **Technology:** Provides short-range communication in the 2.4 GHz band.
 - **Versions:** From Bluetooth 1.0 to 5.4, offering improvements in data rate, range, and power efficiency.
 - **Applications:** Wireless headphones, keyboards, and device pairing.
- **Satellite Communication:**
 - **Technology:** Uses satellites in various orbits to relay signals over long distances.
 - **Applications:** Global communication, broadcasting, weather monitoring, and navigation.
- **Broadcasting Systems:**
 - **Types:** Includes AM, FM, and digital formats like Digital Audio Broadcasting (DAB) and (DVB).
 - **Applications:** Radio and television broadcasting to broad audiences.
- **Long Range Wide Area Networks (LoRaWAN):**
 - **Technology:** Utilizes low-power protocols for long-range, low-data-rate communication.

CHAPTER 4 WIRELESS NETWORK ARCHITECTURES

T.DIVYA MANOHARI

*Assistant Professor, Department of ECE
Ponnaiyah Ramajayam Institute of Science and Technology, Tamil Nadu, India.*

1. Cellular Network Architecture

- **Structure:** Divides the area into cells, each served by a base station (cell tower) for frequency reuse.
- **Components:**
 - **Base Stations:** Manage communication between mobile devices and the network.
 - **Mobile Switching Center (MSC):** Handles call routing and handovers.
 - **HLR and VLR:** Store subscriber data and manage location updates.
- **Applications:** Mobile phones, data services, IoT devices.

2. Wi-Fi Network Architecture

- **Structure:** Consists of access points (APs) that provide wireless connectivity and connect to a wired network.
- **Components:**
 - **Access Points (APs):** Enable devices to connect wirelessly.
 - **Router/Gateway:** Connects the Wi-Fi network to the internet and manages traffic.
- **Standards:** Includes IEEE 802.11n, 802.11ac, and 802.11ax (Wi-Fi 6) for various speeds and capacities.
- **Applications:** Local area networks (LANs) in homes, offices, and public areas.

3. Bluetooth Network Architecture

- **Structure:**
 - **Master-Slave:** One master device controls the network; other devices act as slaves.
 - **Piconets:** Small networks with one master and up to seven slaves.
 - **Scatternets:** Interconnected piconets allowing devices to join multiple networks.
- **Applications:** Short-range communication between devices like headphones and keyboards.

4. Satellite Network Architecture

- **Structure:** Uses satellites in various orbits to relay signals over long distances.
- **Components:**
 - **Satellites:** Provide global coverage.
 - **Ground Stations:** Interface between satellites and terrestrial networks.
 - **User Terminals:** Devices connecting to the satellite network.
- **Applications:** Global communication, television broadcasting, weather monitoring, navigation.

5. Zigbee Network Architecture

- **Structure:**
 - **Coordinator:** Manages network formation and security.
 - **Routers:** Extend network range by forwarding messages.
 - **End Devices:** Perform functions and communicate through routers or coordinators.

CHAPTER 5 ADVANCED WIRELESS TECHNOLOGIES

A.AARTHI

Assistant Professor, Department of ECE

Ponnaiyah Ramajayam Institute of Science and Technology, Tamil Nadu, India.

Advanced wireless technologies are transforming connectivity by boosting data rates, cutting latency, and enabling new applications. Here's a snapshot of key advancements:

1. 5G Technology

- **Overview:** The fifth generation of mobile networks, surpassing 4G in several ways.
 - **High Data Rates:** Speeds over 10 Gbps.
 - **Low Latency:** As low as 1 millisecond, ideal for real-time applications.
 - **Massive Connectivity:** Supports up to 1 million devices per square kilometer.
 - **Enhanced Reliability:** Improved coverage and network stability.
- **Applications:** Mobile broadband, IoT, autonomous vehicles, augmented reality (AR), and virtual reality (VR).

2. Millimeter-Wave Technology

- **Overview:** Uses high-frequency bands (24 GHz to 100 GHz) for communication.
 - **High Capacity:** Provides large bandwidth for extremely high data rates.
 - **Short Range:** Limited by atmospheric absorption, necessitating small cell networks.
- **Applications:** 5G networks, high-speed data transmission, and advanced wireless backhaul.

3. Terahertz Communication

- **Overview:** Explores terahertz (THz) frequencies (0.1 to 10 THz) for ultra-fast data transfer.
 - **Ultra-High Data Rates:** Capable of exceeding 100 Gbps.
 - **Short Range:** High atmospheric attenuation, suitable for short-range use.
- **Applications:** High-speed wireless networks, imaging systems, and secure data transmission.

4. Orthogonal Frequency Division Multiplexing (OFDM)

- **Overview:** Divides the spectrum into multiple orthogonal subcarriers for digital transmission.
 - **Efficient Spectrum Use:** Reduces interference and enhances data rates.
 - **Robustness:** Effective against multipath interference and signal degradation.
- **Applications:** Wi-Fi (802.11a/g/n/ac/ax), LTE, and 5G.

5. Massive MIMO (Multiple Input Multiple Output)

- **Overview:** Uses a large number of antennas at the base station to enhance network performance.
 - **Increased Capacity:** Supports numerous users with high data rates.
 - **Enhanced Beamforming:** Improves signal precision and quality.
- **Applications:** 5G networks and high-capacity wireless systems.

WIDE BAND GAP DEVICES

Edited by
S.LILYPET



978-93-6255-468-0

WIDE BAND GAP DEVICES

COPYRIGHT @ 2023 BY S.LILLYPET

ALL RIGHTS RESERVED. NO PART OF THIS BOOK MAY BE REPRODUCED OR TRANSMITTED IN ANY FORM OR BY ANY MEANS WITHOUT WRITTEN PERMISSION FROM THE AUTHOR.

ISBN: 9789362554680

PUBLISHER: Ponnaiyah Ramajayam Institute of Science and Technology (PRIST)

TABLE OF CONTENTS

| CHAPTER | CONTENT | PAGE |
|----------------|--|-------------|
| | INTRODUCTION | 5 |
| 1 | WIDE BANDGAP SEMICONDUCTORS S.LILLYPET | 20 |
| 2 | FUNDAMENTAL PROPERTIES OF WIDE BANDGAP DEVICES Dr. S. DEVI | 36 |
| 3 | SILICON CARBIDE (SIC) R.SARASWATHI | 54 |
| 4 | GALLIUM NITRIDE (GAN) S. MAHESWARAN | 64 |
| 5 | DIAMOND-BASED SEMICONDUCTORS T. DIVYA MANOHARI | 96 |
| 6 | COMPARISON AND SELECTION CRITERIA A.AMUDHA | 108 |
| 7 | MANUFACTURING AND INTEGRATION E. PRIYADHARSHINI | 132 |
| 8 | APPLICATIONS OF WIDE BANDGAP DEVICES S.SARASWATHY | 168 |
| 9 | FUTURE TRENDS OF WIDE BANDGAP DEVICES R.SAVITHA | 190 |
| 10 | EMERGING TECHNOLOGIES OF WIDE BANDGAP DEVICES D.HARIKRISHNAN | 210 |
| | REFERENCES | 227 |

CHAPTER 1 WIDE BANDGAP SEMICONDUCTORS

S.LILLYPET

*Associate Professor, Department of ECE
Ponnaiyah Ramajayam Institute of Science and Technology, Tamil Nadu, India.*

Wide bandgap semiconductors, characterized by a bandgap significantly greater than traditional materials like silicon, offer unique properties advantageous for high-performance and high-power applications. Their bandgap, typically exceeding 2 eV, provides several key benefits:

- **High Breakdown Voltage:** Capable of withstanding higher voltages without failure.
- **High Thermal Conductivity:** Efficient at dissipating heat.
- **High Electron Mobility:** Enables faster switching speeds and reduced conduction losses.
- **High Operating Temperature:** Functions reliably at elevated temperatures.

Major Wide Bandgap Materials

Silicon Carbide (SiC)

- **Bandgap:** ~2.9 eV
- **Advantages:**
 - High thermal conductivity (~3.7 W/cm·K)
 - High breakdown electric field (3-4 MV/cm)
 - Good thermal stability and radiation resistance
- **Applications:**
 - Power electronics (MOSFETs, Schottky diodes)
 - Electric vehicles and renewable energy

Gallium Nitride (GaN)

- **Bandgap:** ~3.4 eV
- **Advantages:**
 - High electron mobility (up to 2000 cm²/V·s)
 - High thermal stability and efficiency
- **Applications:**
 - RF and microwave components (HEMTs)
 - LEDs and laser diodes

Diamond

- **Bandgap:** ~5.5 eV
- **Advantages:**
 - Extremely high thermal conductivity (~22 W/cm·K)
 - Very high breakdown voltage
- **Applications:**
 - High-power and high-frequency electronics
 - Thermal management

CHAPTER 2 FUNDAMENTAL PROPERTIES OF WIDE BANDGAP DEVICES

Dr. S. DEVI

Professor, Department of ECE

Ponnaiyah Ramajayam Institute of Science and Technology, Tamil Nadu, India.

Wide bandgap devices are distinguished by their exceptional material properties, which enable superior performance in demanding applications. Here's a summary of the fundamental properties that set them apart:

1. Bandgap Energy

- **Definition:** The bandgap is the energy difference between the valence band and the conduction band of a semiconductor.
- **Wide Bandgap Characteristics:** Materials with a bandgap greater than 2 eV, such as those used in wide bandgap semiconductors, can handle higher voltages and temperatures compared to traditional materials like silicon.

2. High Breakdown Voltage

- **Definition:** Breakdown voltage is the maximum voltage a semiconductor can endure before electrical breakdown occurs.
- **Advantage:** Wide bandgap materials can withstand higher electric fields, making them ideal for high-voltage applications like power conversion and transmission systems.

3. High Thermal Conductivity

- **Definition:** Thermal conductivity measures a material's ability to conduct heat.
- **Advantage:** Wide bandgap materials often have high thermal conductivity, which aids in efficient heat dissipation. This is crucial for maintaining stability and reliability in high-power devices.

4. High Electron Mobility

- **Definition:** Electron mobility indicates how quickly electrons move through a semiconductor under an electric field.
- **Advantage:** The high electron mobility in wide bandgap semiconductors results in faster switching speeds and lower on-resistance, benefiting high-frequency and high-speed applications.

5. High Operating Temperature

- **Definition:** The operating temperature range is the spectrum within which a semiconductor device functions effectively.
- **Advantage:** These materials can operate at significantly higher temperatures without performance degradation, making them suitable for harsh environments, such as those found in aerospace and automotive applications.

CHAPTER 3 SILICON CARBIDE (SiC)

R.SARASWATHI

Assistant Professor, Department of ECE

Ponnaiyah Ramajayam Institute of Science and Technology, Tamil Nadu, India.

Silicon Carbide (SiC) is a wide bandgap semiconductor renowned for its exceptional properties, making it ideal for high-performance and high-power applications. Here's a concise overview:

1. Material Properties

- **Bandgap:** Approximately 2.9 eV. This wide bandgap enables SiC devices to operate at higher voltages and temperatures compared to silicon-based devices.
- **Thermal Conductivity:** Around 3.7 W/cm·K, significantly higher than silicon, which facilitates efficient heat dissipation and makes SiC suitable for high-power applications.
- **Breakdown Voltage:** Capable of withstanding high electric fields (~3-4 MV/cm), allowing it to handle high voltages without breakdown.

2. Advantages of SiC

- **High Power Density:** SiC's ability to operate at elevated temperatures and voltages allows for more compact and efficient designs, reducing the overall size and weight of devices.
- **Enhanced Efficiency:** SiC devices feature lower on-resistance and reduced conduction losses compared to silicon, leading to lower energy consumption and reduced heat generation.
- **Thermal Stability:** Can function effectively at temperatures up to 600°C, compared to silicon's limit of around 150°C, making it suitable for harsh and high-temperature environments.

3. Fabrication Techniques

- **Physical Vapor Transport (PVT):** Used for growing single-crystal SiC by sublimating SiC and depositing it onto a seed crystal.
- **Chemical Vapor Deposition (CVD):** Employed for growing thin films of SiC, providing high-quality, uniform layers on various substrates.

4. Applications

- **Power Electronics:** Widely used in power devices like MOSFETs, Schottky diodes, and IGBTs for applications such as power converters, inverters, and rectifiers in electric vehicles, renewable energy systems, and industrial equipment.
- **Electric Vehicles (EVs):** Improves the efficiency of EV powertrains by enabling faster switching and reducing energy losses, leading to longer driving ranges and better performance.
- **Renewable Energy Systems:** Enhances the efficiency and reliability of power conversion and management in photovoltaic systems and wind turbines.
- **High-Frequency and High-Voltage Applications:** Utilized in RF and microwave devices and high-voltage power supplies due to its capability to handle high power and frequency levels.

CHAPTER 4 GALLIUM NITRIDE (GAN)

S.MAHESWARAN

Assistant Professor, Department of ECE

Ponnaiyah Ramajayam Institute of Science and Technology, Tamil Nadu, India.

Gallium Nitride (GaN) is a wide bandgap semiconductor material renowned for its superior electrical and thermal properties, making it ideal for high-performance and high-power applications.

Here's an overview:

1. Material Properties

- **Bandgap:** Approximately 3.4 eV. This wide bandgap enables GaN devices to operate at higher voltages and temperatures than traditional silicon-based devices.
- **Thermal Conductivity:** About 1.3 W/cm·K, which, though lower than silicon carbide (SiC), still supports efficient heat dissipation in many applications.
- **Electron Mobility:** Up to 2000 cm²/V·s. High electron mobility in GaN contributes to faster switching speeds and reduced on-resistance.

2. Advantages of GaN

- **High Efficiency:** GaN devices offer low on-resistance and high switching speed, leading to reduced energy losses and improved performance in power electronics.
- **High Power Density:** GaN's capability to handle high frequencies and voltages allows for more compact and efficient designs in power converters and RF applications.
- **Thermal Stability:** GaN operates effectively at temperatures up to 200-300°C, making it suitable for harsh environments and high-temperature applications.

3. Fabrication Techniques

- **Metal-Organic Chemical Vapor Deposition (MOCVD):** The primary method for growing high-quality GaN films, involving metal-organic precursors and ammonia to deposit GaN onto substrates.
- **Hydride Vapor Phase Epitaxy (HVPE):** Used for bulk GaN growth by reacting gallium and nitrogen hydrides to produce GaN layers.

4. Applications

- **Power Electronics:** GaN is used in power MOSFETs and Schottky diodes, enhancing efficiency and performance in power converters, inverters, and power management systems.
- **RF and Microwave Devices:** Extensively employed in RF and microwave applications, including high-power amplifiers for communications, radar, and satellite technologies, due to its high-frequency and power handling capabilities.
- **Optoelectronics:** Utilized in LEDs and laser diodes, providing high brightness and efficiency for blue and ultraviolet light-emitting devices.
- **Power Conversion Systems:** Found in fast chargers, power adapters, and other compact systems that benefit from GaN's efficiency and size advantages.

CHAPTER 5 DIAMOND-BASED SEMICONDUCTORS

T. DIVYA MANOHARI

Assistant Professor, Department of ECE

Ponnaiyah Ramajayam Institute of Science and Technology, Tamil Nadu, India.

Diamond-Based Semiconductors are cutting-edge materials known for their remarkable properties, making them ideal for high-performance and high-power applications. Here's a streamlined overview:

1. Material Properties

- **Bandgap:** Approximately 5.5 eV. This wide bandgap enables diamond-based semiconductors to operate at very high voltages and temperatures, surpassing traditional semiconductors.
- **Thermal Conductivity:** About 22 W/cm·K, which is the highest among semiconductors. This exceptional thermal conductivity ensures efficient heat dissipation, crucial for managing power in high-performance devices.
- **Electrical Properties:** Diamond features high carrier mobility and a high breakdown voltage, making it suitable for high-power and high-frequency applications.

2. Advantages

- **High Power Handling:** Diamond's wide bandgap and superior thermal conductivity allow it to handle extremely high power densities and voltages without performance loss.
- **Radiation Resistance:** Diamond's hardness and stability make it highly resistant to radiation, benefiting applications in space and military environments.
- **Durability:** As one of the hardest materials, diamond provides exceptional durability and resistance to wear and damage, making it ideal for demanding applications.

3. Fabrication Techniques

- **Chemical Vapor Deposition (CVD):** The primary method for synthesizing synthetic diamond. CVD deposits carbon atoms onto a substrate from a gas phase to form a diamond film, allowing the production of high-quality, large-area diamond layers.
- **High-Pressure High-Temperature (HPHT):** Used to create natural or high-quality single crystal diamonds by mimicking the conditions under which diamonds naturally form in the Earth.

4. Applications

- **Power Electronics:** Used in high-power devices such as power transistors and diodes, diamond-based semiconductors handle high power densities and voltages, enhancing power conversion and management systems.
- **High-Frequency Devices:** Diamond's high breakdown voltage and carrier mobility make it advantageous for high-frequency and microwave devices, including amplifiers and oscillators.
- **Thermal Management:** Employed in thermal management applications, diamond helps dissipate heat effectively in high-performance electronic and optoelectronic devices.

CHAPTER 6 COMPARISON AND SELECTION CRITERIA

A.AMUDHA

Assistant Professor, Department of ECE

Ponnaiyah Ramajayam Institute of Science and Technology, Tamil Nadu, India

Comparison and Selection Criteria for Wide Bandgap Semiconductors

Wide bandgap semiconductors, including Silicon Carbide (SiC), Gallium Nitride (GaN), and Diamond-based materials, offer distinct properties suited to various high-performance applications.

1. Bandgap Energy

- **SiC:** ~2.9 eV
- **GaN:** ~3.4 eV
- **Diamond:** ~5.5 eV

2. Thermal Conductivity

- **SiC:** ~3.7 W/cm·K
- **GaN:** ~1.3 W/cm·K
- **Diamond:** ~22 W/cm·K

3. Breakdown Voltage

- **SiC:** ~3-4 MV/cm
- **GaN:** ~3-5 MV/cm (varies with device structure)
- **Diamond:** ~10-20 MV/cm

4. Electron Mobility

- **SiC:** ~100-200 cm²/V·s
- **GaN:** ~2000 cm²/V·s
- **Diamond:** ~2000 cm²/V·s

5. Operating Temperature

- **SiC:** Up to ~600°C
- **GaN:** Up to ~200-300°C
- **Diamond:** Up to ~1500°C

6. Cost and Fabrication

- **SiC:** Moderate cost, established fabrication techniques
- **GaN:** Moderate to high cost, advanced fabrication techniques
- **Diamond:** High cost, complex and expensive fabrication

CHAPTER 7 MANUFACTURING AND INTEGRATION

E. PRIYADHARSHINI

*Assistant Professor, Department of ECE
Ponnaiyah Ramajayam Institute of Science and Technology, Tamil Nadu, India.*

1. Silicon Carbide (SiC)

Manufacturing Techniques:

- **Physical Vapor Transport (PVT):** Grows single-crystal SiC by sublimating the material and depositing it onto a seed crystal, producing high-quality wafers.
- **Chemical Vapor Deposition (CVD):** Creates thin SiC films by depositing layers from gaseous precursors, yielding uniform and high-quality films.

Integration Challenges:

- **Substrate Costs:** High energy and precision in production make SiC substrates costly
- **Material Defects:** Defects in SiC wafers can impact device performance. Research aims to enhance substrate quality and minimize defects.

2. Gallium Nitride (GaN)

Manufacturing Techniques:

- **Metal-Organic Chemical Vapor Deposition (MOCVD):** Main method for producing high-quality GaN films using metal-organic precursors and ammonia.

Integration Challenges:

- **Substrate Issues:** GaN is typically grown on sapphire or SiC substrates, leading to lattice mismatches that can affect performance. Improved substrate technologies are being developed.
- **Cost:** GaN devices and substrates are relatively expensive.

3. Diamond-Based Semiconductors

Manufacturing Techniques:

- **Chemical Vapor Deposition (CVD):** The primary method for creating synthetic diamond films by depositing carbon atoms from a gas phase onto a substrate.
- **High-Pressure Temperature (HPHT):** Synthesizes natural or high-quality diamond crystals by replicating the conditions under which diamond forms naturally.

Integration Challenges:

- **Material Defects:** Synthetic diamond can contain defects impacting performance. Advances in fabrication are needed to enhance quality and reduce defects.

CHAPTER 8 APPLICATIONS OF WIDE BANDGAP DEVICES

S.SARASWATHY

Assistant Professor, Department of ECE

Ponnaiyah Ramajayam Institute of Science and Technology, Tamil Nadu, India.

Wide bandgap (WBG) devices, particularly silicon carbide (SiC) and gallium nitride (GaN) semiconductors, are revolutionizing various industries due to their exceptional performance in high-power and high-frequency applications. Here's an overview of their diverse applications:

1. Power Electronics

- **High-Voltage Power Switches:** SiC MOSFETs, with their high breakdown voltage and low on-resistance, are ideal for power inverters, motor drives, and industrial equipment. GaN HEMTs excel in high-speed, efficient switching, making them suitable for power supplies and RF amplifiers.
- **Power Conversion Systems:** DC-DC converters benefit from WBG devices' high efficiency and frequency, reducing size and weight. SiC-based AC-DC rectifiers improve efficiency and power density.
- **Thermal Management and Reliability:** WBG devices handle higher temperatures and power densities, leading to more compact and reliable power electronics.

2. High-Frequency and RF Applications

- **RF Power Amplifiers:** GaN RF Transistors are used in communication systems, including cellular base stations, satellites, and radar, due to their high power density and efficiency.
- **Communication Systems:** GaN amplifiers enhance signal strength and bandwidth in satellites and cellular networks.
- **Radar Systems:** GaN-based radars offer superior range and resolution for military and civilian use.

3. Automotive Applications

- **Electric Vehicles (EVs):** SiC devices enable faster and more efficient on-board charging and improve power density and efficiency in traction inverters, enhancing EV performance and range.
- **Advanced Driver Assistance Systems (ADAS):** GaN devices are utilized in LiDAR systems for high-resolution and high-speed imaging and sensing.

4. Renewable Energy Systems

- **Photovoltaic Systems:** SiC and GaN devices improve efficiency and reduce losses in solar inverters.
- **Wind Turbine Systems:** Power converters using WBG devices enhance efficiency and reliability in converting wind energy.

5. Industrial Applications

- **Motor Drives:** SiC MOSFETs in variable frequency drives (VFDs) provide high efficiency and compactness.
- **Uninterruptible Power Supplies (UPS):** WBG devices enhance reliability and efficiency in UPS systems.
- **Power Distribution Systems:** SiC devices improve performance in high-voltage and high-current distribution networks.

CHAPTER 9 FUTURE TRENDS OF WIDE BANDGAP DEVICES

R.SAVITHA

Assistant Professor, Department of ECE

Ponnaiyah Ramajayam Institute of Science and Technology, Tamil Nadu, India.

The future of wide bandgap (WBG) devices, such as those based on silicon carbide (SiC) and gallium nitride (GaN), is poised for significant advancements that will enhance their performance, expand their applications, and reduce costs. Key trends shaping this future include:

1. Enhanced Material Quality and Reliability

- **Improved Substrate Quality:** Advances in crystal growth and processing techniques will enhance SiC and GaN substrates, reducing defects and boosting device performance.
- **Reliability Improvements:** Ongoing research aims to improve the long-term reliability and thermal stability of WBG devices, addressing challenges like degradation and failure under extreme conditions.

2. Cost Reduction and Scalability

- **Manufacturing Innovations:** New production methods and scaling efficiencies will lower costs, making WBG devices more accessible for diverse applications.
- **Integration and Packaging:** Advances in packaging will facilitate more compact and cost-effective integration of WBG devices into various systems.

3. Higher Power and Frequency Capabilities

- **Increased Power Ratings:** Future developments will enable WBG devices to handle higher voltages and currents, expanding their use in high-power electronics.
- **Higher Frequency Operation:** Improved GaN technology will support higher frequency operations, enhancing RF and microwave applications.

4. Advanced Power Electronics Applications

- **Electric Vehicles (EVs):** Enhancements in SiC MOSFETs and GaN HEMTs will advance EV power systems, leading to more efficient traction inverters and faster charging solutions.
- **Renewable Energy Integration:** WBG devices will optimize energy conversion and management in solar and wind energy systems.

5. Emergence of New Applications

- **Quantum Computing:** Research into WBG materials for quantum computing could enable more efficient and stable processors.
- **5G and Beyond:** The need for high-speed RF components for 5G and future communication technologies will drive greater adoption of GaN devices.

CHAPTER 10 EMERGING TECHNOLOGIES OF WIDE BANDGAP DEVICES

D.HARIKRISHNAN

Assistant Professor, Department of ECE

Ponnaiyah Ramajayam Institute of Science and Technology, Tamil Nadu, India.

Emerging technologies in wide bandgap (WBG) devices, including silicon carbide (SiC) and gallium nitride (GaN), are driving innovation across various fields. Here are some of the most promising developments:

1. Advanced Materials and Structures

- **Diamond-Based Devices:** Diamond's exceptional thermal conductivity and wide bandgap make it a leading candidate for high-performance power electronics and high-frequency applications. Ongoing research aims to enhance fabrication techniques and integration methods for diamond-based WBG devices.
- **III-Nitride Materials Beyond GaN:** Exploration of other III-nitride materials, like aluminum nitride (AlN) and indium gallium nitride (InGaN), seeks to extend the performance capabilities of WBG devices for high-power and high-frequency uses.
- **Heterogeneous Integration:** Combining WBG materials or integrating them with silicon (Si) in hybrid structures can improve performance and reduce costs. For instance, integrating GaN on Si substrates is being developed to leverage existing silicon manufacturing infrastructure.

2. Next-Generation Power Electronics

- **High-Efficiency Power Converters:** Innovations in SiC and GaN technologies are leading to ultra-efficient DC-DC and AC-DC converters, resulting in smaller, lighter, and more efficient power supplies for a range of applications from consumer electronics to industrial systems.
- **Solid-State Circuit Breakers:** WBG devices are enabling the development of high-speed, reliable solid-state circuit breakers, which offer enhanced protection and fault isolation in power systems.

3. Quantum and High-Frequency Applications

- **Quantum Computing:** WBG materials are being investigated for their potential in quantum computing, where their low-temperature stability and performance could benefit quantum bits (qubits) and other components.
- **5G and Beyond RF Components:** GaN devices are enhancing RF components for 5G and future communication technologies, providing higher power density and efficiency for base stations, satellite communications, and radar systems.

4. Automotive and Transportation Innovations

- **On-Board Chargers for EVs:** Next-generation SiC-based chargers are being developed to support ultra-fast charging and improve efficiency in electric vehicles (EVs), including advances in wireless charging technologies.
- **Advanced Driver Assistance Systems (ADAS):** GaN devices are improving ADAS technologies, such as radar and LiDAR systems, by delivering higher resolution and faster data processing.



NETWORKS AND

SECURITY



EDITED BY
S.LILYPET



978-93-6255-331-7

NETWORK AND SECURITY

COPYRIGHT@2023BY S.LILLYPET

ALL RIGHTS RESERVED. NO PART OF THIS BOOK MAY BE REPRODUCED OR TRANSMITTED IN ANY FORM OR BY ANY MEANS WITHOUT WRITTEN PERMISSION FROM THE AUTHOR.

ISBN: 978-93-6255-331-7

PUBLISHER: Ponnaiyah Ramajayam Institute of Science and Technology (PRIST)

TABLE OF CONTENTS

| CHAPTER | CONTENT | PAGE |
|----------------|--|-------------|
| | INTRODUCTION | 5 |
| 1 | SECURITY POLICIES AND PROCEDURES | 13 |
| | R.SARASWATHI | |
| 2 | CRYPTOGRAPHY | 30 |
| | A.AMUDHA | |
| 3 | NETWORK SECURITY PROTOCOLS | 49 |
| | R.SAVITHA | |
| 4 | NETWORK SECURITY ARCHITECTURE | 64 |
| | S.SARASWATHY | |
| 5 | FIREWALLS AND INTRUSION DETECTION SYSTEMS | 85 |
| | E.PRIYADHARSHINI | |
| | REFERENCES | 110 |

CHAPTER 1 SECURITY POLICIES AND PROCEDURES

R.SARASWATHI

Assistant Professor, Department of ECE

Ponnaiyah Ramajayam Institute of Science and Technology, Tamil Nadu, India.

Security policies and procedures are critical components of an organization's information security framework. They establish guidelines for protecting the organization's information assets and help ensure compliance with relevant laws and regulations. Below is an overview of key elements involved in developing and implementing security policies and procedures.

1. Understanding Security Policies

1.1 Definition

Security Policy: A formal document that outlines an organization's security objectives, principles, and the rules governing the protection of its information assets. It serves as a high-level framework guiding all security-related activities.

1.2 Purpose of Security Policies

Establish a clear understanding of security requirements and responsibilities.

Protect sensitive information from unauthorized access, theft, or damage.

Ensure compliance with legal, regulatory, and contractual obligations.

Provide guidance on responding to security incidents and breaches.

2. Key Components of Security Policies

2.1 Information Security Policy

A comprehensive document outlining how an organization protects its information assets. It typically covers:

Data Classification: Categorizing information based on sensitivity and required protection levels.

Access Control: Guidelines for granting and managing access to sensitive information.

Data Encryption: Requirements for encrypting sensitive data in transit and at rest.

Acceptable Use Policy: Rules for appropriate use of organizational IT resources.

2.2 Incident Response Policy

Defines the processes for identifying, responding to, and recovering from security incidents. Key elements include:

Incident Detection: Procedures for identifying potential security incidents.

Incident Reporting: Guidelines for reporting incidents to the appropriate personnel.

Response Actions: Steps to contain, mitigate, and remediate security incidents.

Post-Incident Review: Processes for analyzing incidents and implementing improvements.

2.3 Data Protection Policy

Establishes guidelines for protecting sensitive data throughout its lifecycle. This includes:

Data Handling: Instructions for data collection, storage, transmission, and disposal.

Data Retention: Policies outlining how long data should be retained and when it should be securely deleted.

Backup and Recovery: Requirements for regularly backing up data and procedures for data restoration.

2.4 Access Control Policy

Outlines how access to information systems and data is managed. Key aspects include:

User Authentication: Requirements for verifying user identities (e.g., passwords, multi-factor authentication).

Role-Based Access Control (RBAC): Assigning access rights based on user roles and responsibilities.

Account Management: Processes for creating, modifying, and terminating user accounts.

CHAPTER 2 CRYPTOGRAPHY

A.AMUDHA

Assistant Professor, Department of ECE

Ponnaiyah Ramajayam Institute of Science and Technology, Tamil Nadu, India

Cryptography is the practice and study of techniques for securing communication and information through the use of codes. It is a fundamental aspect of information security, ensuring confidentiality, integrity, authentication, and non-repudiation of data. Here's a detailed overview of the key concepts, techniques, and applications of cryptography:

1. Basic Concepts of Cryptography

1.1 Definitions

Plaintext: The original, readable message or data that is to be protected.

Ciphertext: The encrypted version of the plaintext, which is unreadable without decryption.

Encryption: The process of converting plaintext into ciphertext using a specific algorithm and key.

Decryption: The process of converting ciphertext back into plaintext using the appropriate key.

1.2 Key Concepts

Key: A string of bits used by cryptographic algorithms to transform plaintext into ciphertext and vice versa. The security of the encryption relies heavily on the secrecy and strength of the key.

Algorithm: A mathematical procedure for performing encryption and decryption, defining how the transformation from plaintext to ciphertext and back occurs.

2. Types of Cryptography

2.1 Symmetric Cryptography

Description: Also known as secret-key cryptography, it uses the same key for both encryption and decryption.

Example Algorithms:

Advanced Encryption Standard (AES): A widely used symmetric encryption standard.

Data Encryption Standard (DES): An older standard that is now considered less secure due to its shorter key length.

Advantages: Faster than asymmetric cryptography and suitable for encrypting large amounts of data.

Disadvantages: Key management can be challenging, especially in scenarios involving multiple parties.

2.2 Asymmetric Cryptography

Description: Also known as public-key cryptography, it uses a pair of keys: a public key for encryption and a private key for decryption.

Example Algorithms:

RSA (Rivest-Shamir-Adleman): One of the first public-key cryptosystems, widely used for secure data transmission.

Elliptic Curve Cryptography (ECC): A more efficient form of public-key cryptography that offers similar security with shorter key lengths.

Advantages: Simplifies key distribution and management, as the public key can be shared openly.

Disadvantages: Slower than symmetric cryptography and less efficient for encrypting large amounts of data.

3. Cryptographic Techniques

3.1 Hash Functions

Description: A hash function takes an input (or message) and produces a fixed-size string of characters, which is typically a digest that uniquely represents the input.

Example Algorithms:

SHA-256 (Secure Hash Algorithm 256-bit): Commonly used in blockchain and digital signatures.

MD5 (Message Digest Algorithm 5): An older algorithm that is now considered insecure due to vulnerabilities.

Applications: Data integrity verification, password storage, and digital signatures..

CHAPTER 3 NETWORK SECURITY PROTOCOLS

R.SAVITHA

Assistant Professor, Department of ECE

Ponnaiyah Ramajayam Institute of Science and Technology, Tamil Nadu, India

Network security protocols are essential for protecting data integrity, confidentiality, and availability during transmission over networks. They define rules and procedures for secure communication between devices and users, helping to safeguard against threats such as unauthorized access, data breaches, and tampering. Below is an overview of key network security protocols, their functions, and applications.

1. Secure Socket Layer (SSL) / Transport Layer Security (TLS)

1.1 Description

SSL and its successor, TLS, are cryptographic protocols designed to provide secure communication over a computer network.

1.2 Key Features

Encryption: Protects data in transit by encrypting communication between clients and servers.

Authentication: Ensures that the parties involved in communication are who they claim to be, typically through digital certificates.

Integrity: Uses message authentication codes (MAC) to verify that data has not been altered during transmission.

1.3 Applications

Widely used in HTTPS (HyperText Transfer Protocol Secure) for secure web browsing, online transactions, and email security.

2. Internet Protocol Security (IPsec)

2.1 Description

IPsec is a suite of protocols designed to secure Internet Protocol (IP) communications by authenticating and encrypting each IP packet in a communication session.

2.2 Key Features

Encryption: Uses protocols like Encapsulating Security Payload (ESP) to encrypt data.

Authentication: Provides authentication through protocols like Authentication Header (AH).

Transport and Tunnel Modes: Can operate in transport mode (encrypting only the payload) or tunnel mode (encrypting the entire IP packet).

2.3 Applications

Commonly used in Virtual Private Networks (VPNs) to create secure tunnels for remote access to networks and secure communications over public networks.

3. Secure Hypertext Transfer Protocol (HTTPS)

3.1 Description

HTTPS is an extension of HTTP that uses SSL/TLS to provide a secure channel over a computer network.

3.2 Key Features

Data Encryption: Ensures that data exchanged between a user's browser and a web server is encrypted.

Authentication: Verifies the identity of the websites being accessed through SSL/TLS certificates.

Data Integrity: Protects against data modification during transmission.

3.3 Applications

Essential for secure online banking, e-commerce transactions, and any web applications that handle sensitive data.

4. Simple Network Management Protocol version 3 (SNMPv3)

4.1 Description

SNMP is used for network management and monitoring. SNMPv3 enhances security features over previous versions.

CHAPTER 4 NETWORK SECURITY ARCHITECTURE

S.SARASWATHY

Assistant Professor, Department of ECE

Ponnaiyah Ramajayam Institute of Science and Technology, Tamil Nadu, India.

Network security architecture refers to the design and structure of an organization's network security framework. It encompasses the policies, technologies, and controls implemented to protect the network and its assets from various threats. A well-defined security architecture helps ensure that an organization's information is kept secure while supporting business objectives and operations. Here's a detailed overview of network security architecture, its components, and best practices.

1. Key Concepts in Network Security Architecture

1.1 Defense-in-Depth

Description: A multi-layered approach to security that uses various protective measures at different levels of the network.

Purpose: Reduces the likelihood of a single point of failure and provides multiple barriers to potential threats.

1.2 Security Zones

Description: Dividing the network into segments or zones based on security requirements. Each zone has different access controls and security policies.

Common Zones:

DMZ (Demilitarized Zone): An intermediary network between the internal network and the internet, hosting public-facing services.

Internal Network: Contains sensitive data and resources, accessible only to authorized users.

Guest Network: A separate network for visitors, isolating them from internal resources.

2. Core Components of Network Security Architecture

2.1 Firewalls

Description: Devices or software that monitor and control incoming and outgoing network traffic based on predefined security rules.

Types:

Network Firewalls: Operate at the network layer to filter traffic between different networks.

Application Firewalls: Focus on inspecting and filtering traffic at the application layer.

2.2 Intrusion Detection and Prevention Systems (IDPS)

Description: Systems designed to detect and respond to potential security breaches by monitoring network traffic for suspicious activity.

Types:

Intrusion Detection System (IDS): Monitors and alerts on potential intrusions.

Intrusion Prevention System (IPS): Actively blocks or prevents identified threats.

2.3 Virtual Private Networks (VPNs)

Description: Secure connections that allow remote users to access the internal network securely over the internet.

Functionality: Encrypts data in transit, ensuring confidentiality and integrity while providing secure access to resources.

CHAPTER 5 FIREWALLS AND INTRUSION DETECTION SYSTEMS

E.PRIYADHARSHINI

Assistant Professor, Department of ECE

Ponnaiyah Ramajayam Institute of Science and Technology, Tamil Nadu, India.

NETWORK AND SECURITY (DSP) has a wide range of applications across various fields due to its ability to process signals efficiently and accurately. Below are key applications of DSP in different domains:

1. Audio and Speech Processing

1.1 Audio Enhancement and Equalization

DSP techniques are used in audio equalizers to adjust different frequency bands (bass, mid, treble) for music production, playback systems, and personal audio devices.

DSP is also applied for noise reduction and sound enhancement in audio recordings, helping improve clarity by removing background noise or hiss.

1.2 Speech Compression

In communication systems, DSP is used for speech coding and compression, reducing the amount of data required to transmit voice signals. Techniques like Linear Predictive Coding (LPC) and Code-Excited Linear Prediction (CELP) are widely used in mobile phones and VoIP systems.

1.3 Voice Recognition and Synthesis

DSP is crucial in speech recognition systems for converting spoken words into text, as seen in voice assistants like Siri, Alexa, and Google Assistant.

It is also used in text-to-speech synthesis, enabling computers to "speak" by converting written text into speech.

2. Image and Video Processing

2.1 Image Enhancement

DSP algorithms are applied to enhance digital images by improving their quality through techniques like contrast adjustment, sharpening, and noise reduction. These techniques are common in photo editing software.

2.2 Image Compression

JPEG and MPEG are compression standards that use DSP techniques like the Discrete Cosine Transform (DCT) to reduce the size of images and videos for storage and transmission, while preserving visual quality.

2.3 Video Processing

DSP is essential in video streaming for encoding and compressing video files (e.g., MP4), making it feasible to stream over limited bandwidth without significant loss of quality.

DSP techniques like motion detection and frame interpolation are used in video surveillance and high-definition video playback to improve smoothness.

2.4 Object Recognition

DSP plays a role in object and face recognition systems used in security applications, autonomous vehicles, and smart cameras. Techniques like edge detection and pattern recognition are applied to detect and classify objects in digital images.

3. Telecommunications

3.1 Modulation and Demodulation

DSP is used for modulation and demodulation of signals in communication systems like mobile phones, Wi-Fi, and satellite communications. Techniques like Quadrature Amplitude Modulation (QAM) and Frequency Shift Keying (FSK) rely on DSP for efficient transmission of data.



LINEAR INTEGRATED CIRCUITS

Edited by
S.LILLYPET



978-93-6255-988-1

LINEAR INTEGRATED CIRCUITS

COPYRIGHT@2023BY S.LILLYPET

ALL RIGHTS RESERVED. NO PART OF THIS BOOK MAY BE REPRODUCED OR TRANSMITTED IN ANY FORM OR BY ANY MEANS WITHOUT WRITTEN PERMISSION FROM THE AUTHOR.

ISBN: 978-93-6255-908-1

PUBLISHER: Ponnaiyah Ramajayam Institute of Science and Technology (PRIST)

TABLE OF CONTENTS

| CHAPTER | CONTENT | PAGE |
|----------------|--|-------------|
| | INTRODUCTION | 5 |
| 1 | BASIC OPERATIONAL AMPLIFIER (OP-AMP) CONCEPTS | 13 |
| | P.GEETHA | |
| 2 | OP-AMP APPLICATIONS | 30 |
| | R.SAVITHA | |
| 3 | VOLTAGE REGULATORS | 49 |
| | A. AARTHI | |
| 4 | PHASE-LOCKED LOOPS (PLLS) | 64 |
| | A.AMUDHA | |
| 5 | ANALOG MULTIPLIERS AND DIVIDERS | 85 |
| | R.SAVITHA | |
| | REFERENCES | 110 |

CHAPTER 1 BASIC OPERATIONAL AMPLIFIER (OP-AMP) CONCEPTS P.GEETHA

*Assistant Professor, Department of ECE
Ponnaiyah Ramajayam Institute of Science and Technology, Tamil Nadu, India.*

Operational amplifiers (op-amps) are versatile electronic components widely used in analog circuits. They serve as the building blocks for various applications, including amplification, filtering, integration, and signal processing. Below are the fundamental concepts related to operational amplifiers.

1. Definition of Operational Amplifier

An operational amplifier is a high-gain voltage amplifier with differential inputs (inverting and non-inverting) and typically a single-ended output. It is designed to amplify the difference between the voltages at its two input terminals.

2. Basic Characteristics of Op-Amps

High Input Impedance: Op-amps have a very high input impedance (often in the megaohm range), minimizing the current drawn from the input source and reducing loading effects.

Low Output Impedance: They possess low output impedance, allowing them to drive loads effectively without significant voltage drop.

High Gain: Op-amps typically have a high open-loop gain (often exceeding 100,000), meaning a small input voltage difference can produce a large output voltage.

Differential Input: Op-amps amplify the difference between the voltages at the non-inverting (+) and inverting (-) inputs.

3. Ideal Op-Amp Model

In theoretical discussions, op-amps are often treated as "ideal" components, possessing the following characteristics:

Infinite bandwidth (no frequency limitations)

Perfectly linear behavior (no distortion)

Zero offset voltage (the output is zero when the input is zero)

4. Op-Amp Configurations

Op-amps can be configured in various ways depending on the application. The two primary configurations are:

4.1 Inverting Amplifier

Configuration: The input signal is applied to the inverting terminal (-), and the non-inverting terminal (+) is grounded.

5. Feedback in Op-Amps

Feedback is a crucial concept in op-amp circuits, allowing for stable operation and controlled gain.

5.1 Negative Feedback

Involves feeding a portion of the output back to the inverting input. This stabilizes the gain and improves linearity and bandwidth.

Commonly used in most op-amp configurations to maintain consistent performance.

5.2 Positive Feedback

Involves feeding a portion of the output back to the non-inverting input. It can lead to increased gain and instability, often used in comparator circuits or oscillators.

CHAPTER 2 OP-AMP APPLICATIONS

R.SAVITHA

Assistant Professor, Department of ECE

Ponnaiyah Ramajayam Institute of Science and Technology, Tamil Nadu, India

Operational amplifiers (op-amps) are highly versatile components widely used in various electronic circuits and systems. Their ability to amplify signals, perform mathematical operations, and filter signals makes them essential in many applications. Below are some of the key applications of op-amps:

1. Amplifiers

Op-amps are commonly used to design various types of amplifiers, including:

Inverting Amplifier: Produces an output that is inversely proportional to the input. Commonly used in audio processing.

Non-Inverting Amplifier: Provides a positive gain and maintains the phase of the input signal. Ideal for signal conditioning.

Differential Amplifier: Amplifies the difference between two input signals while rejecting common-mode signals. Useful in sensor applications.

2. Active Filters

Op-amps are used to create active filters, which can filter out unwanted frequency components from a signal:

Low-Pass Filters: Allow signals below a certain cutoff frequency to pass while attenuating higher frequencies.

High-Pass Filters: Allow signals above a certain cutoff frequency to pass while attenuating lower frequencies.

Band-Pass Filters: Allow signals within a specific frequency range to pass, rejecting frequencies outside that range.

Notch Filters: Reject a narrow band of frequencies, useful for eliminating interference.

3. Signal Conditioning

Op-amps are used to prepare signals for further processing:

Voltage Followers (Buffer Amplifiers): Provide high input impedance and low output impedance, isolating stages of a circuit without amplifying the signal.

Instrumentation Amplifiers: Used in applications requiring high precision and low noise, such as medical instrumentation and sensor signal processing.

4. Comparators

Op-amps can be used as comparators to compare two voltages and produce a binary output:

Zero-Crossing Detectors: Detect when a signal crosses zero voltage, often used in phase-locked loops (PLLs).

CHAPTER 3 VOLTAGE REGULATORS

A. AARTHI

Assistant Professor, Department of ECE

Ponnaiyah Ramajayam Institute of Science and Technology, Tamil Nadu, India

Voltage regulators are essential components in electronic circuits that ensure a constant and stable output voltage, regardless of variations in input voltage, load conditions, or other external factors. They are commonly used in power supplies to provide steady voltages to microprocessors, sensors, and other sensitive electronic devices. Below is a comprehensive overview of voltage regulators, their types, and applications.

1. What is a Voltage Regulator?

A voltage regulator is an electrical device designed to automatically maintain a constant voltage level. It takes a variable or unregulated input voltage and converts it to a stable, predefined output voltage, thus protecting electronic devices from voltage fluctuations and ensuring proper operation.

2. Types of Voltage Regulators

Voltage regulators come in different types based on their design, functionality, and applications. The two main categories are linear voltage regulators and switching voltage regulators.

2.1 Linear Voltage Regulators

Linear regulators are simple devices that maintain a steady output voltage by dissipating excess power as heat. They are easy to use but are generally less efficient than switching regulators.

2.1.1 Fixed Output Regulators

Description: Provide a constant output voltage (e.g., 5V, 12V) regardless of input variations.

Examples: 7805 (5V), 7812 (12V) regulators.

2.1.2 Adjustable Output Regulators

Description: Allow for the output voltage to be adjusted using external resistors.

Examples: LM317, LM338, which allow users to select an output voltage within a specific range (e.g., 1.25V to 37V).

2.1.3 Low Dropout (LDO) Regulators

Description: A type of linear regulator that can maintain regulation with a very small difference between the input and output voltage (known as "dropout voltage").

Examples: LT1086, TPS7A4700.

Advantages: Ideal when input voltage is only slightly higher than the desired output, improving efficiency in low voltage applications.

2.2 Switching Voltage Regulators

Switching regulators use high-frequency switching techniques to regulate output voltage, making them far more efficient than linear regulators, especially in situations where there is a significant difference between input and output voltages.

. Voltage Regulator Parameters

Several important parameters define the performance of voltage regulators:

3.1 Output Voltage

The regulated voltage that the device outputs. For fixed regulators, this value is predefined (e.g., 5V, 12V). For adjustable regulators, this value can be set with external components.

3.2 Dropout Voltage

This is the minimum difference between the input voltage and the output voltage for the regulator to maintain proper regulation. LDO regulators have very low dropout voltages (typically less than 1V), while traditional linear regulators may require a 2-3V difference.

CHAPTER 4 PHASE-LOCKED LOOPS (PLLs)

A.AMUDHA

Assistant Professor, Department of ECE

Ponnaiyah Ramajayam Institute of Science and Technology, Tamil Nadu, India.

Phase-Locked Loops (PLLs) are crucial components in modern electronics, particularly in communications and signal processing. They are widely used for synchronizing signals and maintaining stable frequencies, making them invaluable in various applications such as radio, television, and computer systems. Here's a detailed overview of PLLs, their components, operation, applications, and advantages.

1. What is a Phase-Locked Loop (PLL)?

A Phase-Locked Loop (PLL) is a feedback control system that compares the phase of an input signal with the phase of a generated output signal. The primary goal of a PLL is to lock the output frequency and phase to that of the input signal. This allows the PLL to maintain a consistent output even in the presence of variations or disturbances in the input frequency.

2. Components of a PLL

A typical PLL consists of three main components:

Phase Detector (PD): Compares the phase of the input signal with the phase of the output signal. The PD generates an error signal proportional to the phase difference.

Low Pass Filter (LPF): Filters the output of the phase detector to remove high-frequency noise and provides a smooth control signal for the voltage-controlled oscillator (VCO).

Voltage-Controlled Oscillator (VCO): Generates a periodic signal (usually a sine or square wave) whose frequency is controlled by the voltage input from the low-pass filter. The VCO adjusts its frequency based on the error signal to align with the input signal.

3. How a PLL Works

The operation of a PLL can be broken down into the following steps:

Phase Comparison: The phase detector continuously compares the phase of the input signal with the phase of the output signal from the VCO. If there is a phase difference, the PD outputs a corresponding error signal.

Error Signal Filtering: The low-pass filter smooths the error signal, eliminating high-frequency components. This results in a steady control voltage that reflects the average phase difference.

Frequency Adjustment: The control voltage from the LPF is fed to the VCO, which adjusts its frequency according to the control voltage. If the input signal is leading, the VCO decreases its frequency; if the input signal is lagging, the VCO increases its frequency.

Locking: The system continues this feedback loop until the output frequency of the VCO is locked to the input frequency, meaning the phase difference is minimized to zero. At this point, the PLL is said to be in "lock."

4. Applications of PLLs

Phase-Locked Loops have a wide range of applications, including:

Frequency Synthesis: Generating precise frequencies for radio transmitters and receivers. PLLs are used to create stable carrier frequencies in communication systems.

CHAPTER 5 ANALOG MULTIPLIERS AND DIVIDERS

R.SAVITHA

Assistant Professor, Department of ECE

Ponnaiyah Ramajayam Institute of Science and Technology, Tamil Nadu, India.

Analog multipliers and dividers are essential components in analog signal processing systems, used for a variety of applications including modulation, demodulation, and signal mixing. Unlike their digital counterparts, which operate on discrete values, analog multipliers and dividers work directly with continuous signals, making them fundamental in various fields such as telecommunications, audio processing, and instrumentation. Here's an overview of their functions, types, and applications.

1.1 Applications of Analog Multipliers

Amplitude Modulation (AM): Used to modulate a carrier signal with an information signal. The multiplier produces an output that represents the product of the carrier and message signals.

Phase Detection: In phase-locked loops (PLLs) and other applications, analog multipliers are used to determine the phase difference between two signals.

Signal Mixing: Combining two signals for applications such as frequency mixing in RF communications.

Automatic Gain Control (AGC): Adjusting the gain of a signal based on the amplitude of another reference signal.

1.2 Types of Analog Multipliers

Four Quadrant Multiplier: Capable of handling both positive and negative input signals, producing outputs in all four quadrants of the plane.

Analog Multiplier ICs: Integrated circuits such as the AD533 and LM318 that implement multiplier functionality using internal op-amps and resistors.

2. Analog Dividers

Analog dividers perform the opposite function of multipliers; they divide one continuous signal by another. The mathematical representation can be expressed as:

$$V_{out} = V_1 / V_2$$
$$V_{out} = V_2 / V_1$$

where V_{out} is the output voltage, V_1 is the dividend, and V_2 is the divisor.

1 Applications of Analog Dividers

Signal Scaling: Adjusting the amplitude of a signal based on the input of another signal.

Feedback Control Systems: Used in systems where the output needs to be compared and adjusted based on the input signal.

Frequency Division: Dividing frequency signals for generating lower frequency outputs.

2.2 Types of Analog Dividers

Logarithmic Analog Dividers: Utilize logarithmic functions to achieve division. They convert the input signals into logarithmic form, subtract them, and then exponentiate the result.

Analog Divider ICs: Integrated circuits such as the AD734 that specifically perform analog division.

ADVANCED MANAGEMENT ACCOUNTING

Edited by
S.SIVAKUMAR



978-93-6255-870-1

ADVANCED MANAGEMENT ACCOUNTING
Copyright © 2023 by **S.SIVAKUMAR**

All rights reserved. No part of this book may be reproduced or transmitted in any form or by any means without written permission from the author.

ISBN: 978-93-6255-870-1

Publisher: Ponnaiyah Ramajayam Institute of Science and Technology (PRIST)

TABLE CONTENT

| | |
|---|------------|
| CHAPTER-1 Nature and scope of Management Accounting..... | 1 |
| K. SATHYA | |
| CHAPTER-2 Financial Statement Analysis..... | 10 |
| DR.R. RAJAVARDHINI | |
| CHAPTER-3 Working Capital management..... | 20 |
| DR.D. SILAMBARASAN | |
| CHAPTER-4 Marginal costing and differential cost analysis..... | 30 |
| DR.R. SELVARAJ | |
| CHAPTER-5 Capital budgeting..... | 40 |
| DR.S. KAMARAJU | |
| CHAPTER-6 Tools of Management Accounting..... | 50 |
| DR. ANAND | |
| CHAPTER-7 Strategic Role of Management Accountants..... | 60 |
| DR.V. SRIDEVI | |
| CHAPTER-8 Cost-benefit Analysis..... | 70 |
| DR.A. CHANDRASEKARAN | |
| CHAPTER-9 Non-financial measurement of performance..... | 80 |
| DR.D. SILAMBARASAN | |
| CHAPTER-10 CVP analysis and decision making..... | 90 |
| DR.R. SELVARAJ | |
| REFERENCE | 100 |

CHAPTER- 1
NATURE AND SCOPE OF MANAGEMENT ACCOUNTING
K. SATHYA
Department of Commerce
Ponnaiyah Ramajayam Institute of science and Technology(PRIST)

Management accounting is a vital component of organizational management, focusing on providing financial and non-financial information to help managers make informed decisions. It integrates accounting principles with strategic planning, emphasizing the need for data-driven insights in day-to-day operations and long-term strategy.

Nature of Management Accounting

Decision-Making Support: Management accounting provides relevant information that aids in making decisions related to budgeting, forecasting, and financial planning. **Internal Focus:** Unlike financial accounting, which caters to external stakeholders, management accounting is primarily concerned with internal processes, helping managers understand and improve organizational performance. **Future-Oriented:** Management accounting emphasizes projections and future trends rather than historical data, helping organizations anticipate challenges and opportunities. **Relevance Over Rigor:** The focus is on providing relevant information rather than adhering strictly to standardized formats, allowing for flexibility in analysis. **Integration with Other Disciplines:** Management accounting often intersects with finance, economics, and operational management, making it a multidisciplinary field.

Scope of Management Accounting

Cost Management: Involves analyzing and controlling costs to enhance profitability and efficiency. Techniques include cost-volume-profit analysis, budgeting, and standard costing. **Performance Measurement:** Involves assessing the performance of departments, products, and processes through key performance indicators (KPIs) and variance analysis. **Budgeting and Forecasting:** Management accountants prepare budgets that serve as financial plans for the organization, facilitating better resource allocation and financial control. **Financial Planning:** Involves long-term strategic planning, including investment analysis and capital budgeting decisions. **Strategic Management:** Provides insights that inform corporate strategy, helping organizations adapt to market changes and competitive pressures. **Risk Management:** Identifying, analyzing, and mitigating risks that can affect organizational objectives is crucial in management accounting. **Decision Analysis:** Employing various techniques, such as break-even analysis and sensitivity analysis, to evaluate the potential outcomes of different business scenarios. **Internal Control and Governance:** Establishing processes and systems to ensure accountability, compliance, and efficient use of resources.

CHAPTER- 2
FINANCIAL STATEMENT ANALYSIS
DR.R. RAJAVARDHINI
Department of Commerce
Ponnaiyah Ramajayam Institute of science and Technology(PRIST)

Financial statement analysis is the process of evaluating a company's financial statements to assess its performance, stability, and profitability. This analytical approach helps stakeholders—including management, investors, creditors, and analysts—make informed decisions regarding the organization.

Importance of Financial Statement Analysis

Performance Evaluation: Analyzing financial statements helps in understanding how well a company has performed over a specific period, identifying trends, and measuring against benchmarks. **Investment Decisions:** Investors use financial statement analysis to assess the potential for returns on investment, helping them make informed choices about buying, holding, or selling stock. **Credit Assessment:** Creditors analyze financial statements to evaluate the creditworthiness of a company, determining the risk involved in lending money or extending credit. **Strategic Planning:** Management relies on financial analysis to formulate strategies, allocate resources, and make decisions that align with organizational goals. **Compliance and Reporting:** Organizations must adhere to regulatory standards, and thorough financial analysis ensures accurate reporting and compliance with accounting principles.

Types of Financial Statements:

- **Income Statement:** Provides insights into revenue, expenses, and profits over a specific period.
- **Balance Sheet:** Offers a snapshot of a company's assets, liabilities, and equity at a given point in time.
- **Cash Flow Statement:** Tracks the flow of cash in and out of the business, highlighting liquidity and cash management.

Analysis Techniques:

- **Horizontal Analysis:** Compares financial data over multiple periods to identify trends.
- **Vertical Analysis:** Analyzes financial statement items as a percentage of a base figure, allowing for comparison within a single period.
- **Ratio Analysis:** Involves calculating financial ratios (e.g., liquidity ratios, profitability ratios, and solvency ratios) to evaluate financial health and performance.

CHAPTER- 3
WORKING CAPITAL MANAGEMENT
DR.D. SILAMBARASAN
Department of Commerce
Ponnaiyah Ramajayam Institute of science and Technology(PRIST)

Introduction to Working Capital Management

Working capital management is a crucial aspect of financial management that focuses on ensuring a company has sufficient liquidity to meet its short-term obligations and operational needs. It involves managing current assets and current liabilities efficiently to maintain a balance between profitability and risk.

Importance of Working Capital Management

- **Liquidity Maintenance:** Effective management ensures that the company can meet its short-term liabilities, preventing liquidity crises that can disrupt operations.
- **Operational Efficiency:** By managing working capital effectively, companies can optimize their cash flow, ensuring that resources are available for day-to-day operations without excess idle assets.
- **Cost Control:** Efficient working capital management minimizes costs related to borrowing and financing, as well as storage and inventory costs.
- **Risk Mitigation:** Proper management reduces the risk of insolvency and financial distress, enhancing the company's overall financial stability.
- **Profitability Enhancement:** Effective management can lead to improved cash flow, which can be reinvested into the business for growth and expansion.

Components of Working Capital

1. **Current Assets:** These include cash, accounts receivable, inventory, and other assets expected to be converted into cash or consumed within one year.
2. **Current Liabilities:** These consist of obligations the company needs to settle within one year, including accounts payable, short-term loans, and accrued expenses.
3. **Working Capital Formula:** The basic formula for working capital is

Working capital management is essential for maintaining a company's operational efficiency and financial health. By strategically managing current assets and liabilities, organizations can enhance liquidity, reduce costs, and ultimately drive profitability.

CHAPTER- 4
MARGINAL COSTING AND DIFFERENTIAL COST ANALYSIS
DR.R. SELVARAJ
Department of Commerce
Ponnaiyah Ramajayam Institute of science and Technology(PRIST)

Marginal Costing and Differential Cost Analysis

Marginal Costing and **Differential Cost Analysis** are two important concepts in managerial accounting that assist in decision-making, especially related to pricing, production, and profitability. Both approaches emphasize the behavior of costs and their impact on business decisions.

Marginal Costing

Definition: Marginal costing refers to the cost incurred to produce one additional unit of a product. It includes only variable costs—such as direct materials, direct labor, and variable overhead—while fixed costs are treated as period costs and are not allocated to individual units of production.

- Simplifies cost analysis and enhances clarity.
- Helps in understanding the impact of sales volume on profitability.
- Assists in break-even analysis and planning.

Definition: Differential cost analysis involves comparing the costs of two or more alternatives to determine the financial impact of choosing one option over another. It focuses on the changes in costs that will occur as a result of a specific decision.

Relevant Costs: Only the costs that differ between alternatives are considered, making it a useful tool for short-term decision-making.

Incremental Costs: Analyzes the additional or incremental costs associated with a decision, helping to identify the most financially viable option.

Application: Commonly used in make-or-buy decisions, product line decisions, and pricing strategies.

- Provides a clear framework for decision-making by focusing on relevant costs.
- Helps identify the best alternative among multiple options.
- Facilitates quick assessments in dynamic business environments.

Both marginal costing and differential cost analysis are valuable tools in managerial accounting. Marginal costing aids in understanding the behavior of costs concerning production levels, while differential cost analysis helps evaluate financial implications of different choices. Together, they enhance strategic decision-making and promote effective financial management in organizations.

CHAPTER- 5
CAPITAL BUDGETING
DR.S. KAMARAJU
Department of Commerce
Ponnaiyah Ramajayam Institute of science and Technology(PRIST)

Capital budgeting is a critical financial management process that organizations use to evaluate and prioritize investments in long-term assets. It involves assessing the potential profitability and risks associated with capital expenditures, ensuring that resources are allocated efficiently to projects that align with the company's strategic goals.

Long-Term Financial Planning: Capital budgeting helps organizations plan for long-term growth and sustainability by identifying projects that will contribute to future revenue and profitability.

Resource Allocation: It enables companies to allocate their limited resources effectively among competing investment opportunities, maximizing returns on investment.

Risk Assessment: Capital budgeting involves analyzing the risks associated with different projects, helping businesses make informed decisions that mitigate potential losses.

Performance Measurement: It establishes benchmarks for evaluating the performance of capital projects, facilitating accountability and continuous improvement.

Strategic Alignment: Capital budgeting ensures that investments are in line with the overall strategic objectives of the organization, fostering cohesive growth.

Identifying Investment Opportunities: This involves recognizing potential projects or asset acquisitions that require significant capital.

Cash Flow Projections: Estimating the future cash inflows and outflows associated with each project is essential for assessing feasibility and profitability.

Capital budgeting is essential for guiding organizations in making sound investment decisions that drive long-term growth and profitability. By systematically evaluating potential projects and their financial implications, businesses can ensure that their capital is employed effectively to achieve strategic objectives.

CHAPTER- 6
TOOLS OF MANAGEMENT ACCOUNTING
DR. ANAND
Department of Commerce
Ponnaiyah Ramajayam Institute of science and Technology(PRIST)

Management accounting provides a variety of tools and techniques that aid managers in making informed decisions, optimizing operations, and enhancing overall business performance. These tools focus on analyzing financial and non-financial data to support planning, control, and decision-making processes.

Tools of Management Accounting

Budgeting: Involves preparing detailed financial plans for future periods, guiding resource allocation and setting performance targets.

Variance Analysis: Compares actual performance against budgeted figures to identify discrepancies and understand their causes, aiding in corrective action.

Cost-Volume-Profit (CVP) Analysis: Examines the relationship between costs, sales volume, and profits, helping managers make decisions related to pricing and production levels.

Activity-Based Costing (ABC): Allocates overhead costs based on activities that drive costs, providing a more accurate picture of product profitability.

Financial Ratios: Analyzing ratios such as liquidity, profitability, and solvency helps assess a company's financial health and operational efficiency.

Key Performance Indicators (KPIs): Metrics that provide insights into critical aspects of performance, enabling managers to monitor progress and adjust strategies accordingly.

Balanced Scorecard: A strategic planning and management system that measures organizational performance across multiple perspectives—financial, customer, internal processes, and learning and growth.

Scenario Planning: Involves forecasting different future scenarios and analyzing their impact on business operations, facilitating proactive decision-making.

The tools of management accounting play a vital role in enhancing decision-making, performance evaluation, and strategic planning within organizations. By leveraging these tools, managers can gain valuable insights that drive efficiency, reduce costs, and promote long-term success.

CHAPTER- 7
STRATEGIC ROLE OF MANAGEMENT ACCOUNTANTS
DR.V. SRIDEVI
Department of Commerce
Ponnaiyah Ramajayam Institute of science and Technology(PRIST)

Management accountants play a pivotal role in the strategic planning and decision-making processes within organizations. Their expertise extends beyond traditional financial reporting, as they provide insights and analyses that help shape business strategies and drive organizational success.

Importance of the Strategic Role

Business Strategy Development: Management accountants contribute to the formulation of business strategies by analyzing financial data and market trends, ensuring that decisions are data-driven and aligned with organizational goals.

Performance Management: They design and implement performance measurement systems that monitor key performance indicators (KPIs), enabling organizations to evaluate progress and make necessary adjustments.

Risk Management: Management accountants assess financial risks and uncertainties, helping organizations identify potential threats and develop mitigation strategies.

Resource Allocation: By providing insights into cost structures and profitability, they assist in effective resource allocation, ensuring that investments align with strategic priorities.

Cross-Functional Collaboration: Management accountants work closely with various departments, fostering collaboration and ensuring that financial considerations are integrated into all aspects of the business.

Responsibilities of Management Accountants in Strategy

Financial Planning and Analysis (FP&A): They conduct comprehensive analyses of financial data to inform strategic decisions, budgeting, and forecasting.

Cost Management: Management accountants identify cost drivers and develop strategies to optimize costs while maintaining quality and efficiency.

Investment Appraisal: They evaluate potential investments and projects using techniques like net present value (NPV) and internal rate of return (IRR) to assess their viability and alignment with strategic goals.

Scenario Analysis and Modeling: Management accountants create financial models to simulate different business scenarios, helping leadership understand potential outcomes and make informed choices.

Communication of Financial Insights: They translate complex financial information into clear, actionable insights for non-financial managers, supporting effective decision-making across the organization.

The strategic role of management accountants is essential in today's dynamic business environment. By providing valuable financial insights and analyses, they support strategic planning, risk management, and performance evaluation, ultimately contributing to the long-term success and sustainability of the organization.

CHAPTER- 8
COST-BENEFIT ANALYSIS
DR.A. CHANDRASEKARAN
Department of Commerce
Ponnaiyah Ramajayam Institute of science and Technology(PRIST)

Cost-Benefit Analysis

Cost-Benefit Analysis (CBA) is a systematic approach used to evaluate the economic feasibility of a project or decision by comparing the total expected costs against the total expected benefits. This tool helps organizations make informed decisions by quantifying the trade-offs involved in various alternatives.

Importance of Cost-Benefit Analysis

Informed Decision-Making: CBA provides a clear framework for assessing the financial implications of different options, facilitating rational decision-making.

Resource Allocation: It helps prioritize projects or investments by identifying those that offer the greatest net benefits, ensuring efficient use of resources.

Risk Assessment: By quantifying potential costs and benefits, CBA allows organizations to evaluate risks associated with different decisions.

Transparency and Accountability: A well-documented CBA promotes transparency in decision-making processes and holds decision-makers accountable for their choices.

Communication Tool: CBA provides a clear narrative that can be communicated to stakeholders, helping them understand the rationale behind decisions.

Steps in Conducting Cost-Benefit Analysis

Define the Project or Decision: Clearly outline the scope and objectives of the project or decision to be analyzed.

Identify Costs and Benefits:

Costs: Include both direct costs (e.g., materials, labor) and indirect costs (e.g., overhead, opportunity costs).

Benefits: Consider both tangible benefits (e.g., increased revenue) and intangible benefits (e.g., improved customer satisfaction).

Quantify Costs and Benefits: Assign monetary values to all identified costs and benefits to facilitate comparison. This may involve market research, expert estimates, or historical data.

Discount Future Values: If the analysis covers multiple years, future costs and benefits should be discounted to present value using an appropriate discount rate.

CHAPTER- 9
NON-FINANCIAL MEASUREMENT OF PERFORMANCE
DR.D. SILAMBARASAN
Department of Commerce
Ponnaiyah Ramajayam Institute of science and Technology(PRIST)

Non-financial measurements of performance are essential for providing a holistic view of an organization's effectiveness and success. While financial metrics like profit and revenue are crucial, non-financial indicators help capture aspects such as customer satisfaction, employee engagement, operational efficiency, and innovation, which can significantly impact long-term success.

Importance of Non-Financial Performance Measurement

Comprehensive Performance Insight: Non-financial metrics complement financial data, providing a more complete picture of organizational performance and health.

Strategic Alignment: These measurements help ensure that organizational activities align with strategic goals, fostering a culture of accountability and continuous improvement.

Customer Focus: Metrics like customer satisfaction and retention rates highlight areas for improvement and help in building long-term relationships with clients.

Employee Engagement: Assessing factors like employee satisfaction and turnover rates can enhance workforce morale and productivity, ultimately benefiting the organization.

Operational Efficiency: Non-financial metrics such as process cycle times, quality measures, and resource utilization reveal operational strengths and weaknesses.

Customer Metrics:

Customer Satisfaction Score (CSAT): Measures how satisfied customers are with a product or service.

Net Promoter Score (NPS): Gauges customer loyalty and the likelihood of recommending the company to others.

Customer Retention Rate: Indicates the percentage of customers who continue to do business with the organization over a given period.

Non-financial measurements of performance provide valuable insights into various dimensions of an organization's operations. By focusing on customer satisfaction, employee engagement, operational efficiency, and innovation, organizations can foster a culture of continuous improvement that complements financial performance, ultimately driving long-term success and sustainability.

CHAPTER- 10
CVP ANALYSIS AND DECISION MAKING
DR.R. SELVARAJ
Department of Commerce
Ponnaiyah Ramajayam Institute of science and Technology(PRIST)

Cost-Volume-Profit (CVP) Analysis is a financial modeling tool that helps organizations understand the relationships between costs, sales volume, and profit. By analyzing how changes in cost and volume affect a company's operating income and net profit, CVP analysis supports strategic decision-making.

Importance of CVP Analysis

Profit Planning: CVP analysis assists in setting profit targets and developing budgets by identifying the sales volume needed to achieve desired profit levels.

Cost Structure Understanding: It provides insights into fixed and variable costs, enabling better cost management and pricing strategies.

Break-Even Analysis: CVP helps determine the break-even point—the level of sales at which total revenues equal total costs—allowing organizations to assess risk.

Decision Support: It aids in making informed decisions about pricing, product mix, market expansion, and discontinuation of unprofitable products.

Scenario Analysis: CVP analysis allows organizations to simulate different scenarios (e.g., changes in sales volume, costs, and prices) and assess their potential impacts on profitability.

Components of CVP Analysis

Fixed Costs: Costs that do not change with the level of production or sales (e.g., rent, salaries).

Variable Costs: Costs that vary directly with the level of production or sales (e.g., raw materials, direct labor).

Sales Price per Unit: The amount charged to customers for each unit sold.

Contribution Margin: The difference between sales revenue and variable costs. It indicates how much revenue contributes to covering fixed costs and generating profit:

Contribution Margin = Sales Price - Variable Cost

Contribution Margin = Sales Price - Variable Cost

Break-Even Point: Calculated using the formula:

Break-Even Point (in units) = Total Fixed Costs / Contribution Margin per Unit

Break-Even Point (in units) = Contribution Margin per Unit / Total Fixed Costs

TOTAL QUALITY MANAGEMENT

EDITED BY
P.SAMPATHKUMAR



978-93-6255-041-5

TOTAL QUALITY MANAGEMENT

Copyright © 2023 by **P.SAMPATHKUMAR**

All rights reserved. No part of this book may be reproduced or transmitted in any form or by any means without written permission from the author.

ISBN: 978-93-6255-041-5

Publisher: Ponnaiyah Ramajayam Institute of Science and Technology (PRIST)

TABLE CONTENTS

| | |
|--|--|
| CHAPTER-1 Introduction of Total Quality Management.....1 DR.S.RAJENDRAN | |
| CHAPTER-2 Total Quality Management and Leadership.....10 DR.S.KAMARAJU | |
| CHAPTER-3 Quality Management Tools for Business Applications.....20 DR.A.CHANDRASEKARAN | |
| CHAPTER-4 Quality Imperatives for Business Improvement.....30 DR.ANAND | |
| CHAPTER-5 TQM Implementation Strategies.....40 DR.G.KARTHIGA | |
| CHAPTER-6 Product Development.....50 DR.S.KAMARAJU | |
| CHAPTER-7 Statistical Process.....60 DR.V.SRIDEVI | |
| CHAPTER-8 Benchmarking.....70 DR.R .RAJAVARDHINI | |
| CHAPTER-9 Supplier partnership80 DR.V.SRIDEVI | |
| CHAPTER-10 Cost of Quality90 K.SATHYA | |
| REFERENCE.....100 | |

CHAPTER- 1
INTRODUCTION OF TOTAL QUALITY MANAGEMENT
DR.S.RAJENDRAN
Department of Commerce
Ponnaiyah Ramajayam Institute of science and Technology(PRIST)

Total Quality Management (TQM) is a comprehensive management approach aimed at improving organizational effectiveness by emphasizing quality in all aspects of operations. Rooted in the belief that continuous improvement is essential, TQM involves the participation of all employees, from top management to frontline workers.

The core principles of TQM include a strong focus on customer satisfaction, data-driven decision-making, and a commitment to continuous improvement. By fostering a culture of quality, organizations can enhance their products and services, reduce waste, and improve overall efficiency.

TQM integrates various quality management tools and methodologies, such as Six Sigma and the Plan-Do-Check-Act (PDCA) cycle, to achieve sustainable results. Ultimately, the goal of TQM is to create a high-performance organization that consistently meets or exceeds customer expectations while maintaining a competitive edge in the marketplace.

Enhanced Customer Satisfaction: TQM focuses on understanding and meeting customer needs, leading to improved customer loyalty and retention.

Continuous Improvement: TQM encourages a culture of ongoing enhancement in processes, products, and services, fostering innovation and adaptability.

Employee Engagement: By involving all employees in the quality management process, TQM promotes teamwork, accountability, and job satisfaction, resulting in higher morale.

Operational Efficiency: TQM helps identify and eliminate inefficiencies, reducing waste and optimizing resources, which leads to cost savings.

Competitive Advantage: Organizations implementing TQM can differentiate themselves in the market by consistently delivering high-quality products and services.

Data-Driven Decisions: TQM relies on statistical analysis and metrics to inform decisions, improving accuracy and effectiveness in problem-solving.

Better Risk Management: By focusing on quality processes, organizations can identify potential issues early, reducing the likelihood of costly errors and enhancing overall stability.

Increased Market Share: A strong reputation for quality can attract new customers and expand market presence, driving growth and profitability.

CHAPTER- 2
TOTAL QUALITY MANAGEMENT AND LEADERSHIP
DR.S.KAMARAJU
Department of Commerce
Ponnaiyah Ramajayam Institute of science and Technology(PRIST)

Total Quality Management (TQM) is an organizational philosophy centered on continuous improvement, customer satisfaction, and the involvement of all employees in enhancing processes, products, and services. Effective leadership plays a critical role in the successful implementation and sustainability of TQM principles.

Leaders set the tone for a quality-driven culture by promoting values such as collaboration, accountability, and innovation. They are responsible for creating an environment where employees feel empowered to contribute to quality initiatives and are motivated to pursue excellence.

In TQM, leadership is not limited to upper management; it extends to all levels of the organization. Effective leaders in a TQM framework foster open communication, provide necessary training and resources, and encourage cross-functional teamwork. They also emphasize the importance of data-driven decision-making and lead by example in the pursuit of quality.

Ultimately, the interplay between TQM and leadership is crucial for cultivating a culture of quality that can drive organizational success and adaptability in an ever-evolving marketplace.

Leadership is the art of influencing and guiding individuals or groups toward the achievement of common goals. It encompasses a range of skills, traits, and practices that enable leaders to inspire and motivate others, foster collaboration, and drive organizational success. Effective leadership is not confined to formal positions of authority; it can be exhibited by anyone in an organization, regardless of their role.

At its core, leadership involves setting a vision, communicating it clearly, and aligning team members to work collectively toward that vision. Successful leaders cultivate trust and respect, encourage innovation, and support the development of their team members. They also adapt their leadership style to meet the needs of their followers and the challenges of the environment.

In today's dynamic and complex world, strong leadership is essential for navigating change, fostering resilience, and achieving sustained growth. Whether in business, non-profits, or community organizations, the impact of effective leadership is profound, shaping cultures and influencing outcomes at every level.

CHAPTER- 3
QUALITY MANAGEMENT TOOLS FOR BUSINESS APPLICATIONS
DR.A.CHANDRASEKARAN
Department of Commerce
Ponnaiyah Ramajayam Institute of science and Technology(PRIST)

Quality management tools are essential for businesses to ensure that their products and services meet customer expectations and regulatory requirements. Here are some key tools and techniques widely used in quality management:

Total Quality Management (TQM)

A holistic approach focused on long-term success through customer satisfaction. Emphasizes continuous improvement and the involvement of all employees.

Six Sigma

A data-driven methodology aimed at reducing defects and improving process quality.

Utilizes statistical tools and techniques, like DMAIC (Define, Measure, Analyze, Improve, Control).

Kaizen

A Japanese term meaning "continuous improvement."

Focuses on small, incremental changes that lead to significant improvements over time.

Quality Control (QC) Tools

Control Charts: Monitor process stability and variability over time.

Pareto Analysis: Identifies the most significant factors in a dataset (80/20 rule).

Fishbone Diagram (Ishikawa): Identifies root causes of problems.

Quality Assurance (QA)

Involves systematic processes to ensure that quality requirements are met.

Includes audits and process evaluations.

ISO Standards

International standards (e.g., ISO 9001) that provide frameworks for quality management systems.

Help organizations ensure consistent quality in products and services.

Process Mapping

Visual representation of workflows to identify inefficiencies and areas for improvement.

Helps in understanding the sequence of activities and interactions.

Statistical Process Control (SPC)

Uses statistical methods to monitor and control processes.

Helps maintain process consistency and quality.

CHAPTER- 4
QUALITY IMPERATIVES FOR BUSINESS IMPROVEMENT
DR. ANAND
Department of Commerce
Ponnaiyah Ramajayam Institute of science and Technology(PRIST)

Quality imperatives are critical for driving business improvement and ensuring sustained success. Here are some key quality imperatives that organizations should focus on:

1. Customer Focus

- **Understand Needs:** Regularly gather and analyze customer feedback to understand expectations and preferences.
- **Enhance Satisfaction:** Deliver products and services that consistently meet or exceed customer expectations.

2. Leadership Commitment

- **Vision and Culture:** Establish a clear vision for quality and foster a culture that prioritizes quality at all levels of the organization.
- **Empower Employees:** Encourage leadership to support teams and provide the necessary resources for quality initiatives.

3. Continuous Improvement

- **Adopt Kaizen Principles:** Encourage a mindset of ongoing enhancement in processes, products, and services.
- **Set Improvement Goals:** Define measurable goals and regularly review progress.

4. Data-Driven Decision Making

- **Utilize Analytics:** Leverage data and metrics to identify trends, performance gaps, and areas for improvement.
- **Root Cause Analysis:** Implement systematic approaches to analyze problems and prevent recurrence.

5. Process Optimization

- **Map and Analyze Processes:** Clearly document and assess workflows to identify inefficiencies and bottlenecks.
- **Standardize Best Practices:** Establish standard operating procedures to ensure consistency and efficiency.

6. Employee Engagement and Training

- **Invest in Training:** Provide ongoing education and training on quality management principles and practices.
- **Encourage Involvement:** Involve employees in quality initiatives and empower them to suggest improvements.

CHAPTER- 5
TQM IMPLEMENTATION STRATEGIES
DR.G. KARTHIGA
Department of Commerce
Ponnaiyah Ramajayam Institute of science and Technology(PRIST)

Introduction to Total Quality Management (TQM)

Total Quality Management (TQM) is a comprehensive approach focused on improving organizational processes, products, and services through continuous quality enhancement. TQM integrates all members of an organization in the pursuit of quality improvement, emphasizing a customer-centric mindset, teamwork, and data-driven decision-making. The core philosophy of TQM revolves around the idea that every employee, at every level, plays a vital role in delivering quality.

TQM Implementation Strategies

To successfully implement TQM, organizations can adopt the following strategies:

1. Leadership Commitment

- Strong leadership is essential for TQM success. Leaders should promote a quality-driven culture, provide resources, and support quality initiatives.

2. Establish a Quality Vision

- Develop a clear vision for quality that aligns with the organization's overall mission. This vision should be communicated to all employees.

3. Employee Training and Development

- Invest in training programs to equip employees with the necessary skills and knowledge to contribute to quality improvement efforts.

4. Cross-Functional Teams

- Form teams comprising members from different departments to foster collaboration and address quality issues holistically.

5. Customer Focus

- Regularly gather and analyze customer feedback to ensure products and services meet their expectations and requirements.

6. Data Collection and Analysis

- Implement systems for collecting and analyzing data on quality metrics, enabling informed decision-making and process improvement.

CHAPTER- 6
PRODUCT DEVELOPMENT
DR.S.KAMARAJU

Department of Commerce
Ponnaiyah Ramajayam Institute of science and Technology(PRIST)

Introduction to Product Development

Product development is a crucial process that involves the creation, design, and introduction of new products or improvements to existing ones. It encompasses a wide range of activities, from ideation and concept development to market launch and post-launch evaluation. This process not only aims to meet customer needs but also to align with market trends and technological advancements.

Importance of Product Development

- **Meeting Customer Needs:** Effective product development ensures that products address the evolving needs and preferences of customers.
- **Competitive Advantage:** Organizations that innovate and introduce new products can differentiate themselves from competitors and capture market share.
- **Revenue Growth:** New products can open up additional revenue streams and contribute significantly to a company's overall growth.
- **Brand Strengthening:** Successful product development enhances brand reputation and loyalty by delivering quality and value to customers.
- **Adaptation to Market Trends:** Continuous product development helps businesses stay relevant in rapidly changing markets by adapting to new trends and technologies.

Components of Product Development

1. **Idea Generation**
 - The initial stage where ideas are brainstormed based on market research, customer feedback, and technological innovations.
2. **Concept Development**
 - Refining the best ideas into clear concepts that outline the product's purpose, features, and benefits.
3. **Feasibility Analysis**
 - Assessing the technical and economic viability of the product, including cost estimates and resource requirements.
4. **Design and Prototyping**
 - Creating detailed designs and prototypes to visualize the product and test its functionality.
5. **Testing and Validation**
 - Conducting tests to gather feedback, identify issues, and ensure the product meets quality standards and customer expectations.

CHAPTER- 7
STATISTICAL PROCESS
DR.V. SRIDEVI

Department of Commerce
Ponnaiyah Ramajayam Institute of science and Technology(PRIST)

Introduction to Statistical Process Control (SPC)

Statistical Process Control (SPC) is a methodology used to monitor, control, and improve processes through the use of statistical tools and techniques. It plays a critical role in quality management, helping organizations ensure that their processes operate efficiently and produce consistent, high-quality products and services.

Concepts of SPC

Variation in Processes

All processes exhibit variation, which can be categorized into two types: common cause variation (inherent to the process) and special cause variation (due to specific, identifiable factors). SPC aims to identify and manage these variations.

Control Charts

Control charts are one of the primary tools in SPC. They graphically display process data over time, allowing for the visualization of variations and the determination of whether a process is in control or if corrective action is needed.

Process Capability

This involves assessing a process's ability to produce outputs that meet specifications. Statistical measures like C_p and C_{pk} are used to quantify process capability.

Data Collection and Analysis

SPC relies on the systematic collection and analysis of data to make informed decisions. This includes identifying patterns, trends, and potential issues within processes.

Quality Improvement:

By identifying variations and their causes, SPC helps organizations implement corrective actions, leading to improved product quality.

Reduced Waste:

SPC minimizes waste and inefficiencies by ensuring processes remain stable and predictable.

Enhanced Decision-Making: Data-driven insights allow for better decision-making regarding process improvements and resource allocation.

Increased Customer Satisfaction:

Consistent quality and reliability in products enhance customer trust and satisfaction.

Compliance and Standards:

SPC helps organizations adhere to industry standards and regulatory requirements by maintaining control over processes.

CHAPTER- 8
BENCHMARKING
DR.R .RAJAVARDHINI
Department of Commerce

Ponnaiyah Ramajayam Institute of science and Technology(PRIST)

Introduction to Benchmarking

Benchmarking is a systematic process of comparing an organization's processes, performance metrics, and practices against those of industry leaders or competitors. This practice helps organizations identify areas for improvement, set performance standards, and adopt best practices to enhance efficiency and effectiveness.

Types of Benchmarking

Internal Benchmarking:

Comparison of processes within different departments or divisions of the same organization.

Competitive Benchmarking:

Evaluation against direct competitors to understand relative performance.

Functional Benchmarking:

Comparison with organizations in similar functions or industries, regardless of direct competition.

Generic Benchmarking:

Broad comparisons across industries to find innovative practices that can be adapted.

Importance of Benchmarking

- **Performance Improvement:**
Helps organizations identify performance gaps and implement best practices to enhance efficiency.
- **Goal Setting:**
Provides a clear understanding of industry standards, facilitating realistic and achievable goal setting.
- **Innovation:**
Exposure to new ideas and practices from other organizations can foster innovation and creative solutions.
- **Competitive Advantage:**
Organizations can gain insights that lead to improved products, services, and customer satisfaction.
- **Informed Decision-Making:**
Data-driven comparisons provide a solid foundation for strategic decisions and resource allocation.

CHAPTER- 9
SUPPLIER PARTNERSHIP
DR.V.SRIDEVI
Department of Commerce
Ponnaiyah Ramajayam Institute of science and Technology(PRIST)

Introduction to Supplier Partnership

Supplier partnership refers to a collaborative relationship between an organization and its suppliers, aimed at creating mutual value through shared goals, transparency, and long-term commitment. This strategic alliance enhances supply chain performance, fosters innovation, and contributes to overall business success.

Elements of Supplier Partnership

Mutual Trust and Respect

Building a foundation of trust encourages open communication and collaboration between organizations and their suppliers.

Shared Goals and Objectives

Aligning goals ensures that both parties work toward common outcomes, such as quality improvement, cost reduction, and market responsiveness.

Effective Communication

Ongoing dialogue fosters understanding and problem-solving, allowing for quick responses to challenges and changes in demand.

Continuous Improvement

Partners engage in joint efforts to enhance processes, products, and services, driving innovation and efficiency.

Risk Management

Collaborating on risk assessment and mitigation strategies strengthens the resilience of the supply chain.

Supplier partnerships are essential for organizations looking to optimize their supply chains and achieve competitive advantage. By fostering collaboration and commitment, businesses can enhance quality, drive innovation, and ensure long-term success in a dynamic marketplace.

CHAPTER- 10
COST OF QUALITY
K. SATHYA

Department of Commerce
Ponnaiyah Ramajayam Institute of science and Technology(PRIST)

Introduction to Cost of Quality (CoQ)

Cost of Quality (CoQ) refers to the total costs incurred by an organization to ensure that products and services meet quality standards. It encompasses the costs associated with preventing poor quality, appraising quality, and addressing defects. Understanding CoQ helps organizations identify areas for improvement, reduce waste, and enhance overall profitability.

Components of Cost of Quality

Prevention Costs

Expenses related to activities aimed at preventing defects and ensuring quality from the outset. This includes training, quality planning, and process improvement initiatives.

Appraisal Costs

Costs incurred to evaluate and measure the quality of products and services. This includes inspection, testing, and quality audits to ensure compliance with standards.

Internal Failure Costs

Costs associated with defects found before the product or service is delivered to the customer. This includes rework, scrap, and downtime due to quality issues.

External Failure Costs

Costs that arise when defects are discovered after delivery to the customer. This includes warranty claims, returns, and the costs of addressing customer complaints.

Improved Decision-Making:

Analyzing CoQ enables organizations to make informed decisions about quality investments and resource allocation.

Enhanced Profitability:

Reducing failure costs through better prevention and appraisal can lead to significant cost savings and improved margins.

Increased Customer Satisfaction:

By focusing on quality, organizations can enhance customer satisfaction, loyalty, and brand reputation.

Continuous Improvement:

Understanding CoQ highlights areas for improvement, driving continuous quality enhancement initiatives.

SMART GRID

Edited by

DR. B. KUNJITHAPATHAM



978-93-6255-447-5

Smart Grid
Copyright © 2023 by Dr. B. Kunjithapatham

All rights reserved. No part of this book may be reproduced or transmitted in any form or by any means without written permission from the author.

ISBN: 978-93-6255-447-5

Publisher: Ponnaiyah Ramajayam Institute of Science and Technology (PRIST)
Date of Publication : 12.10.23

TABLE OF CONTENTS

| | |
|--|------------|
| Introduction | 04 |
| CHAPTER 1 - Introduction to smart grid | 20 |
| Mrs.N.Prasannadevi | |
| CHAPTER 2 – Smart metering | 39 |
| Mr.R.Elangovan | |
| CHAPTER 3 - Smart grid technologies in Transmission | 63 |
| Dr.S.Ezhilarasan | |
| CHAPTER 4 – Smart grid technologies in Distribution | 125 |
| Mr.D.Hariharan | |
| CHAPTER 5 – Smart grid applications | 148 |
| Mr.M.Anand | |
| CHAPTER 6 – Protection and control | 156 |
| Mrs.N.Prasannadevi | |
| CHAPTER 7 – Basics of Micro grid | 162 |
| Mr.R.Elangovan | |
| CHAPTER 8 – Smart energy resources | 174 |
| Dr.S.Ezhilarasan | |
| CHAPTER 9 – Local Area Network | 186 |
| Mr.D.Hariharan | |
| CHAPTER 10 – Cyber Security for Smart Grid | 191 |
| Mr.M.Anand | |
| REFERENCES | 206 |

CHAPTER 1

Introduction to smart grid

Mrs.N.Prasannadevi

A smart grid is an advanced electrical grid system that uses digital communication and technology to enhance the efficiency, reliability, and sustainability of electricity distribution. It enables real-time monitoring and management of energy flows, integrates renewable energy sources, and allows for better demand response and grid resilience.

Key Features of a Smart Grid

- **Real-Time Monitoring:** Smart grids use sensors and advanced metering infrastructure to provide real-time data on electricity flow and grid conditions. This allows for immediate response to any issues or imbalances.
- **Advanced Communication Systems:** They incorporate digital communication networks that enable two-way interaction between utilities and consumers, as well as between different parts of the grid.
- **Automated Controls:** Smart grids use automated systems to manage and optimize the flow of electricity, enhance reliability, and reduce operational costs.
- **Integration of Renewable Energy:** They are designed to accommodate various renewable energy sources like solar, wind, and hydro, managing their intermittent nature and ensuring a stable energy supply.

Benefits of a Smart Grid

- **Increased Reliability and Resilience:** The ability to detect and address problems in real-time reduces the frequency and duration of power outages.
- **Enhanced Efficiency:** Smart grids optimize energy use and reduce losses through better management and control, leading to lower operational costs and environmental impact.
- **Consumer Engagement:** Provides detailed usage information and control options, empowering consumers to make informed decisions and manage their energy consumption more effectively.
- **Sustainability:** Facilitates the integration of clean energy sources and supports efforts to reduce greenhouse gas emissions and reliance on fossil fuels.

Challenges and Considerations

- **Cybersecurity:** The increased connectivity of the grid raises concerns about potential cyber threats and the need for robust security measures.
- **Cost:** Initial setup and integration of smart grid technology can be expensive, though the long-term benefits often justify the investment.
- **Complexity:** Managing a more sophisticated grid requires advanced technology and skilled personnel to handle the complexities and ensure smooth operation.

The Future of Smart Grids

As technology advances, smart grids are expected to become even more integrated and intelligent, incorporating innovations like artificial intelligence, machine learning, and more advanced renewable energy solutions. They are key to building a sustainable energy future, addressing both current and future challenges in electricity management.

Components of a Smart Grid:

- **Smart Meters:** Measure energy consumption in real-time and provide detailed data to both consumers and utilities.

CHAPTER 2

Smart metering

Mr.R.Elangovan

Smart metering is a critical component of the smart grid that involves the use of advanced digital meters to measure and record energy consumption in real-time. Unlike traditional analog meters, which only provide cumulative consumption data periodically (e.g., monthly), smart meters offer continuous, detailed, and precise readings of energy usage.

Key Features of Smart Metering

1. Real-Time Data Collection:

- **Instant Readings:** Smart meters provide up-to-date information on energy consumption, allowing for real-time monitoring and management.
- **Detailed Usage Information:** They can track consumption patterns at various times of the day, giving both consumers and utilities valuable insights into energy use.

2. Two-Way Communication:

- **Data Transmission:** Smart meters communicate usage data to utility companies automatically and securely, reducing the need for manual meter readings.
- **Remote Management:** Utilities can remotely manage and adjust settings on smart meters, including disconnecting or reconnecting service if necessary.

3. Enhanced Accuracy:

- **Precise Measurements:** Smart meters reduce human error and inaccuracies associated with manual readings, ensuring more accurate billing.

4. Consumer Access:

- **Energy Usage Insights:** Consumers often have access to detailed consumption data via online portals or mobile apps, enabling them to monitor and manage their energy use more effectively.
- **Alerts and Notifications:** Some smart meters can send alerts about unusual consumption patterns or potential issues, helping users to address problems promptly.

Benefits of Smart Metering

1. Improved Billing Accuracy:

- **No Estimated Bills:** Smart meters eliminate the need for estimated billing, as readings are precise and reflect actual consumption.
- **Reduced Disputes:** Accurate, real-time data helps resolve billing disputes more quickly and fairly.

2. Enhanced Energy Management:

- **Informed Decisions:** Consumers can make better energy choices based on detailed usage data, potentially leading to cost savings.
- **Demand Response:** Utilities can use data to manage peak demand more effectively and implement demand response programs that encourage consumers to shift usage to off-peak times.

3. Operational Efficiency:

- **Reduced Manual Labor:** Automated readings cut down on the need for manual meter reading, lowering operational costs.
- **Faster Issue Detection:** Utilities can quickly identify and address issues such as power outages or system faults through real-time data.

4. Support for Renewable Energy:

- **Integration:** Smart meters help manage and integrate distributed renewable energy sources by providing real-time data on both generation and consumption.

CHAPTER 3

Smart grid technologies in Transmission

Dr.S.Ezhilarasan

In the context of transmission, smart grid technologies enhance the efficiency, reliability, and management of electricity delivery from power plants to consumers. Here are some key technologies and their roles:

1. Advanced Sensors and Phasor Measurement Units (PMUs):

- **Real-Time Monitoring:** These devices measure electrical parameters such as voltage and current at various points in the transmission network. They provide data for real-time grid monitoring and fault detection.
- **Stability Analysis:** PMUs help in analyzing and maintaining grid stability by providing high-precision, time-synchronized measurements.

2. Automated Control Systems:

- **Dynamic Line Rating (DLR):** DLR systems adjust the capacity of transmission lines based on real-time weather and environmental conditions, optimizing line usage and reducing congestion.
- **Fault Detection and Isolation:** Automated systems quickly detect faults and isolate problematic sections of the grid, minimizing the impact on overall transmission and reducing outage durations.

3. High Voltage Direct Current (HVDC) Transmission:

- **Long-Distance Transmission:** HVDC technology is used for efficient long-distance transmission of electricity, particularly from remote renewable energy sources to urban centers.
- **Stability and Control:** HVDC systems enhance grid stability and control by allowing for better management of power flows between different regions or grids.

4. Energy Storage Integration:

- **Grid Stabilization:** Energy storage systems, such as batteries or pumped hydro, are integrated into the transmission network to store excess energy during low demand periods and release it during peak times, aiding in grid stability and load balancing.
- **Frequency Regulation:** Storage systems help regulate grid frequency by quickly responding to fluctuations in power supply and demand.

5. Smart Grid Communication Networks:

- **Data Exchange:** These networks facilitate real-time communication between various grid components, enabling effective monitoring, control, and coordination across the transmission network.
- **Cybersecurity:** Advanced communication networks include robust security measures to protect against cyber threats and ensure reliable data transmission.

6. Demand Response and Grid Management:

- **Load Management:** Smart grid technologies support demand response programs by adjusting energy consumption patterns based on grid conditions, helping to manage peak loads and prevent congestion.
- **Predictive Analytics:** Advanced analytics tools forecast demand and supply patterns, aiding in proactive grid management and planning.

7. Renewable Energy Integration:

- **Flexible Infrastructure:** Smart transmission technologies facilitate the integration of variable renewable energy sources, such as wind and solar, by managing their intermittent nature and ensuring reliable delivery.

CHAPTER 4

Smart grid technologies in Distribution

Mr.D.Hariharan

Smart grid technologies in the distribution sector focus on improving the efficiency, reliability, and responsiveness of electricity distribution from substations to end-users. Here's a detailed look at some key technologies used in the distribution grid:

1. Smart Meters:

- **Real-Time Consumption Data:** Smart meters provide detailed, real-time information on electricity usage, enabling both consumers and utilities to track and manage energy consumption more effectively.
- **Two-Way Communication:** They facilitate two-way communication between the grid and customers, allowing for remote meter reading, billing, and troubleshooting.

2. Advanced Distribution Management Systems (ADMS):

- **Real-Time Monitoring and Control:** ADMS integrates data from various sources to monitor and control the distribution network in real-time, enhancing operational efficiency and grid reliability.
- **Fault Detection and Isolation:** These systems quickly identify and isolate faults, reducing the duration and impact of outages.

3. Distribution Automation:

- **Automated Switching:** Technologies like automated circuit breakers and reclosers enable automated switching operations to reroute power and isolate faults, minimizing outages and improving service reliability.
- **Self-Healing Grids:** Distribution automation systems can automatically detect, isolate, and correct issues, allowing the grid to "self-heal" and maintain service continuity during disruptions.

4. Voltage Regulation and Power Quality:

- **Voltage Regulators:** Devices such as automatic voltage regulators and tap-changing transformers manage voltage levels to ensure stable power quality and protect equipment.
- **Reactive Power Compensation:** Technologies like capacitor banks and STATCOMs (Static Synchronous Compensators) help manage reactive power, maintain voltage stability, and improve power quality.

5. Demand Response and Load Management:

- **Dynamic Load Management:** Smart grid technologies enable real-time adjustments to electricity demand, helping to balance supply and demand, reduce peak loads, and prevent grid congestion.
- **Consumer Participation:** Demand response programs incentivize consumers to adjust their energy use during peak periods, contributing to overall grid stability and efficiency.

6. Energy Storage Systems:

- **Distributed Energy Storage:** Batteries and other energy storage systems are deployed at various points in the distribution network to store excess energy and release it when needed, aiding in load balancing and grid stability.
- **Grid Support:** Storage systems provide ancillary services such as frequency regulation and voltage support, enhancing the overall performance of the distribution network.

CHAPTER 5

Smart grid applications

Mr.M.Anand

Smart grid applications leverage advanced technologies and digital communication to enhance various aspects of electricity generation, distribution, and consumption. Here's an overview of key applications within a smart grid:

Real-Time Monitoring and Control

- **Grid Health Monitoring:** Sensors and Phasor Measurement Units (PMUs) provide real-time data on grid conditions, such as voltage, current, and frequency, allowing operators to monitor the health and stability of the grid.
- **Automated Control Systems:** Automated systems can adjust operations based on real-time data to optimize performance and respond to changing grid conditions.

Advanced Metering Infrastructure (AMI)

- **Smart Metering:** Smart meters measure and report energy usage in real-time, providing accurate billing and detailed consumption data to both utilities and consumers.
- **Remote Meter Reading:** Utilities can remotely read meters, reducing the need for manual readings and enabling more frequent and accurate data collection.

Demand Response Management

- **Dynamic Load Management:** Systems adjust electricity consumption based on real-time grid conditions, encouraging users to shift their usage to off-peak times or reduce consumption during peak periods.
- **Consumer Incentives:** Utilities offer incentives for customers to participate in demand response programs, helping to balance supply and demand and reduce grid stress.

Energy Storage Management

- **Battery Storage:** Energy storage systems, such as lithium-ion batteries, store excess energy during periods of low demand and release it during peak times, enhancing grid stability and load balancing.
- **Pumped Hydro Storage:** Large-scale storage systems that use excess energy to pump water to a higher elevation and release it to generate electricity when needed.

Renewable Energy Integration

- **Distributed Generation Management:** Systems manage the integration of distributed renewable energy sources (e.g., solar panels, wind turbines) into the grid, balancing their intermittent output with demand.
- **Microgrid Operation:** Microgrids can operate independently or in conjunction with the main grid, enhancing resilience and allowing for localized control of renewable resources.

Grid Resilience and Reliability

- **Fault Detection and Isolation:** Automated systems quickly detect and isolate faults in the grid, minimizing the impact of outages and improving overall reliability.
- **Self-Healing Grids:** Technologies enable the grid to automatically reconfigure and restore service after a fault, reducing outage times and improving service continuity.

Advanced Distribution Management Systems (ADMS)

- **Real-Time Optimization:** ADMS tools optimize the operation of the distribution network by analyzing data from various sources to improve efficiency, reduce losses, and enhance reliability.

CHAPTER 6

Protection and control

Mrs.N.Prasannadevi

Protection Systems

- **Fault Detection and Isolation:** Systems like relay protection and automated circuit breakers detect faults (short circuits, overloads) and isolate affected sections to minimize damage and prevent widespread outages.
- **Relay Coordination:** Protection relays are coordinated to ensure the appropriate response to faults, minimizing the impact on the overall grid while ensuring that only the affected areas are isolated.

Smart Relays

- **Digital Relays:** Modern digital relays offer advanced protection functions, real-time monitoring, and programmable settings to adapt to different grid conditions and operational requirements.
- **Communicating Relays:** These relays communicate with other devices in the grid, enhancing coordination and providing detailed fault analysis.

Substation Automation

- **SCADA Systems (Supervisory Control and Data Acquisition):** SCADA systems enable real-time monitoring and control of substations, integrating data from various sensors and devices for effective grid management.
- **Remote Control and Diagnostics:** Allows operators to remotely control substation equipment, perform diagnostics, and make adjustments without needing physical access.

Dynamic Line Rating (DLR)

- **Real-Time Capacity Monitoring:** DLR systems dynamically assess the capacity of transmission lines based on real-time conditions (temperature, weather) to optimize line usage and prevent overloads.

Voltage and Reactive Power Control

- **Automatic Voltage Regulators (AVRs):** AVRs adjust voltage levels to maintain stability and protect equipment from voltage fluctuations.
- **Reactive Power Compensation:** Devices like capacitors and STATCOMs (Static Synchronous Compensators) manage reactive power to maintain voltage stability and improve power quality.

Advanced Distribution Management Systems (ADMS)

- **Real-Time Grid Management:** ADMS provides real-time visibility and control over the distribution network, enabling quick response to issues and optimized grid performance.
- **Fault Location, Isolation, and Service Restoration (FLISR):** ADMS automates the process of detecting faults, isolating them, and restoring service, reducing outage times and improving reliability.

Self-Healing Grids

- **Automatic Reconfiguration:** The grid can automatically reconfigure itself to restore service after a fault, rerouting power around problem areas and reducing the impact of outages.
- **Adaptive Protection:** Protection systems adapt to changing grid conditions and configurations, enhancing resilience and reducing the likelihood of cascading failures.

Cybersecurity Measures

- **Secure Communications:** Encryption and other security protocols protect data transmitted between grid devices, safeguarding against cyber threats.

CHAPTER 7

Basics of Micro grid

Mr.R.Elangovan

A **microgrid** is a localized, small-scale energy system that can operate independently or in conjunction with the main electrical grid. It typically serves a specific geographic area, such as a neighborhood, campus, or industrial site. Here are the basics:

Components

- **Generation Sources:** Includes various energy sources such as solar panels, wind turbines, or diesel generators.
- **Energy Storage:** Batteries or other storage systems to store excess energy for use during peak times or outages.
- **Distribution Infrastructure:** Includes transformers, switches, and wiring to distribute electricity within the microgrid.
- **Control Systems:** Manage the generation, distribution, and consumption of energy within the microgrid, ensuring stable operation and efficiency.

Operation Modes

- **Grid-Connected Mode:** The microgrid operates in sync with the main grid, taking advantage of grid power when available and providing excess power back to the grid.
- **Islanded Mode:** The microgrid can disconnect from the main grid and operate independently during outages or other disruptions, using its local generation and storage resources.

Benefits

- **Enhanced Reliability:** Provides a backup power source during main grid outages, improving energy security and resilience.
- **Local Energy Management:** Enables more efficient use of local renewable resources and energy storage, reducing reliance on external power sources.
- **Reduced Energy Costs:** Can potentially lower energy costs by optimizing local generation and consumption and taking advantage of peak shaving and load management strategies.

Control and Automation

- **Microgrid Controllers:** Coordinate the operation of various components, managing energy flows, ensuring stability, and transitioning between grid-connected and islanded modes.
- **Advanced Management Systems:** Use real-time data and predictive analytics to optimize performance, balance supply and demand, and handle disturbances.

Integration with Distributed Energy Resources (DERs)

- **DER Management:** Integrates various distributed energy sources, such as renewable generation and combined heat and power (CHP) systems, into the microgrid.
- **Demand Response:** Adjusts local energy consumption based on availability and grid conditions to enhance efficiency and reduce costs.

Applications

- **Critical Facilities:** Used in hospitals, data centers, and military bases where continuous power supply is crucial.
- **Remote Areas:** Provides power to isolated regions that are not connected to the main grid.
- **Sustainable Communities:** Supports eco-friendly developments by integrating renewable energy and improving local energy efficiency.

CHAPTER 8

Smart energy resources

Dr.S.Ezhilarasan

Smart energy resources are advanced technologies and systems that improve the efficiency, reliability, and sustainability of energy generation, distribution, and consumption. Here's a look at key types of smart energy resources:

Smart Meters

- **Real-Time Data:** Measure and report energy usage in real-time, providing accurate billing and detailed consumption insights.
- **Two-Way Communication:** Facilitate remote meter reading and data exchange between consumers and utilities.

Energy Storage Systems

- **Batteries:** Lithium-ion, flow, and other types of batteries store excess energy for later use, balancing supply and demand and enhancing grid stability.
- **Pumped Hydro Storage:** Uses surplus energy to pump water to a higher elevation and releases it to generate power when needed.

Distributed Generation

- **Solar Panels:** Convert sunlight into electricity, reducing reliance on the central grid and supporting renewable energy goals.
- **Wind Turbines:** Generate power from wind, contributing to a diversified and sustainable energy mix.

Demand Response Technologies

- **Smart Thermostats:** Adjust heating and cooling based on real-time data and user preferences, helping to manage energy consumption and reduce peak loads.
- **Automated Load Control:** Systems that adjust or shift energy use in response to grid conditions, helping balance supply and demand.

Electric Vehicles (EVs)

- **Smart Charging:** Manages EV charging times and rates to avoid grid congestion and integrate with renewable energy sources.
- **Vehicle-to-Grid (V2G):** Enables EVs to return stored energy to the grid, providing additional storage and supporting grid stability.

Building Energy Management Systems (BEMS)

- **Energy Optimization:** Integrate with building systems (HVAC, lighting, etc.) to monitor and control energy use for greater efficiency and cost savings.
- **Real-Time Monitoring:** Provides insights into energy consumption patterns and helps identify opportunities for improvement.

Smart Appliances

- **Energy-Efficient Devices:** Appliances that use advanced technology to reduce energy consumption and can be controlled remotely or programmed for optimal use.
- **Grid-Responsive Features:** Capable of adjusting operations based on grid signals or demand response events.

CHAPTER 9

Local Area Network

Mr.D.Hariharan

A **Local Area Network (LAN)** is a network that connects computers and devices within a limited geographic area, such as a home, office, or campus. Here's a brief overview:

Components

- **Network Devices:** Includes routers, switches, hubs, and access points that facilitate communication between devices.
- **End Devices:** Computers, printers, smart phones, and other devices that connect to the network.
- **Cabling and Wireless:** Uses Ethernet cables or Wi-Fi for connectivity.

Types of LANs

- **Wired LAN:** Uses Ethernet cables to connect devices, offering high speed and reliability.
- **Wireless LAN (WLAN):** Utilizes Wi-Fi technology to connect devices wirelessly, providing flexibility and ease of installation.

Network Topologies

- **Star Topology:** All devices connect to a central hub or switch, which manages communication between them.
- **Bus Topology:** Devices are connected along a single central cable, with terminators at each end.
- **Ring Topology:** Devices are connected in a circular fashion, with each device connected to two others.

IP Addressing

- **Static IP:** Fixed IP addresses assigned manually to devices.
- **Dynamic IP:** IP addresses assigned automatically by a DHCP server, which manages address allocation.

Security Measures

- **Firewalls:** Protect the network from unauthorized access and threats.
- **Encryption:** Secures data transmitted over the network, especially in wireless LANs.
- **Access Control:** Ensures only authorized users and devices can access network resources.

Network Management

- **Monitoring Tools:** Track network performance, usage, and potential issues.
- **Configuration Management:** Involves setting up and maintaining network devices and settings.

Applications

- **File Sharing:** Allows users to share documents, images, and other files across devices.
- **Printers and Peripherals:** Enables multiple devices to use shared printers and other peripherals.
- **Internet Access:** Provides access to the internet through a shared connection.

Network Devices

1. **Routers:**
 - **Function:** Direct traffic between different networks (e.g., between a local network and the internet).
 - **Features:** Often include built-in firewalls, DHCP servers, and NAT (Network Address Translation) to manage IP addressing and security.
 - **Example:** Home routers that connect your home network to the internet.
2. **Switches:**
 - **Function:** Connect multiple devices within the same network and manage data traffic efficiently by using MAC addresses to forward data only to the intended device.
 - **Features:** Can be managed or unmanaged; managed switches offer more control over network traffic and performance.
 - **Example:** Office switches that connect computers, printers, and servers within a company.

CHAPTER 10

Cyber Security for Smart Grid

Mr.M.Anand

Cybersecurity for smart grids is crucial due to the increasing complexity and connectivity of modern electrical grids. Smart grids integrate various digital technologies, which, while enhancing efficiency and reliability, also introduce vulnerabilities that need to be addressed. Here's an overview of key aspects and strategies for ensuring cyber security in smart grids:

Understanding Smart Grid Vulnerabilities

- **Increased Attack Surface:** The integration of IT and OT (Operational Technology) systems, along with numerous connected devices, expands the potential points of attack.
- **Critical Infrastructure:** Smart grids are vital for national infrastructure, making them a high-value target for cyberattacks.
- **Legacy Systems:** Older components may not be designed with modern cybersecurity threats in mind, creating potential vulnerabilities.

Key Cybersecurity Strategies

1. **Network Segmentation:**
 - **Purpose:** Divide the network into segments to limit the spread of a potential attack and protect critical systems.
 - **Implementation:** Use firewalls, VLANs (Virtual Local Area Networks), and DMZs (Demilitarized Zones) to create isolated network segments.
2. **Access Control:**
 - **Authentication:** Implement strong authentication mechanisms, such as multi-factor authentication (MFA), to control access to network resources.
 - **Authorization:** Ensure users and devices have the appropriate level of access to perform their roles without exposing sensitive areas.
3. **Encryption:**
 - **Data-in-Transit:** Use encryption protocols (e.g., TLS/SSL) to secure data transmitted between devices and systems.
 - **Data-at-Rest:** Encrypt stored data to protect it from unauthorized access and breaches.
4. **Monitoring and Detection:**
 - **Intrusion Detection Systems (IDS):** Monitor network traffic for suspicious activity and potential threats.
 - **Security Information and Event Management (SIEM):** Aggregate and analyze security data from across the network to detect and respond to incidents.
5. **Incident Response:**
 - **Plan Development:** Create and regularly update an incident response plan to address potential cybersecurity incidents.
 - **Response Team:** Establish a dedicated team to manage and respond to cybersecurity incidents.
6. **Regular Updates and Patch Management:**
 - **Software Updates:** Keep all software and firmware up-to-date with the latest security patches.
 - **Vulnerability Management:** Regularly assess systems for vulnerabilities and apply patches or mitigations as needed.
7. **Threat Intelligence:**
 - **Information Sharing:** Participate in threat intelligence sharing platforms to stay informed about emerging threats and vulnerabilities.
 - **Threat Analysis:** Analyze threat data to understand potential risks and prepare defensive measures.



POWER ELECTRONICS

EDITED BY
DR. P. AVIRAJAMANJULA



978-93-6255-217-4

Power Electronics
Copyright © 2023 by Dr. P. Avirajamanjula

All rights reserved. No part of this book may be reproduced or transmitted in any form or by any means without written permission from the author.

ISBN: 978-93-6255-217-4

Publisher: Ponnaiyah Ramajayam Institute of Science and Technology (PRIST)
Date of Publication : 21.09.23

TABLE OF CONTENTS

| | |
|---|------------|
| Introduction | 03 |
| CHAPTER 1 - Switching power supplies | 18 |
| Dr. P. Avirajamanjula | |
| CHAPTER 2 – Inverters | 35 |
| Dr. P. Avirajamanjula | |
| CHAPTER 3 - Uncontrolled Rectifiers | 68 |
| Dr. P. Avirajamanjula | |
| CHAPTER 4 – Controlled Rectifiers | 115 |
| Dr. P. Avirajamanjula | |
| CHAPTER 5 – AC phase controllers | 138 |
| Dr. P. Avirajamanjula | |
| CHAPTER 6 – Driver and Snubber Circuits | 144 |
| Dr. P. Avirajamanjula | |
| CHAPTER 7 – Buck-Boost Converters | 159 |
| Dr. P. Avirajamanjula | |
| CHAPTER 8 – Resonant Converters | 172 |
| Dr. P. Avirajamanjula | |
| CHAPTER 9 – Voltage Doubler Circuit | 192 |
| Dr. P. Avirajamanjula | |
| CHAPTER 10 – Capacitor Filter for Low Power Rectifiers | 206 |
| Dr. P. Avirajamanjula | |
| REFERENCES | 215 |

CHAPTER 1

Switching power supplies

Dr. P. Avirajamanjula

Switching power supplies, also known as switch-mode power supplies (SMPS), are a type of power supply unit that efficiently converts electrical power from one form to another using electronic switching techniques. They are commonly used in various electronic devices due to their efficiency, compact size, and versatility.

Key Concepts of Switching Power Supplies

1. Basic Operation:

- **Switching:** The core of an SMPS is a high-frequency switching transistor that rapidly turns on and off. This switching action converts the input voltage to a different voltage level with high efficiency.
- **Transformer:** In many SMPS designs, a transformer is used to step up or step down the voltage and provide electrical isolation between the input and output.
- **Rectification and Filtering:** After switching, the AC voltage from the transformer is rectified (converted to DC) and filtered to smooth out the output voltage.

2. Components:

- **Switching Transistor:** The primary component that turns on and off to regulate power. Common types include MOSFETs and IGBTs.
- **Transformer:** Used to isolate and change voltage levels. It also helps in noise reduction and stabilization of the output.
- **Inductors and Capacitors:** Used for filtering and smoothing the voltage to reduce ripple and noise.
- **Control Circuitry:** Manages the switching transistor and ensures the output voltage remains stable despite variations in input voltage or load.

3. Types of Switching Power Supplies:

- **Buck Converter (Step-Down):** Converts a higher input voltage to a lower output voltage. Commonly used in battery-powered devices.
- **Boost Converter (Step-Up):** Converts a lower input voltage to a higher output voltage. Used in applications like LED drivers.
- **Buck-Boost Converter:** Can either step up or step down the input voltage. Useful for applications where the input voltage can vary above and below the desired output voltage.
- **Flyback Converter:** Provides electrical isolation and is commonly used in low-power applications like chargers and small power adapters.
- **Forward Converter:** Similar to the flyback but typically used for higher power applications.
- **Push-Pull Converter:** Uses two transistors in a push-pull arrangement to improve efficiency and power handling in medium to high-power applications.

4. Control Methods:

- **Voltage Mode Control:** Regulates the output voltage by adjusting the duty cycle of the switching transistor.
- **Current Mode Control:** Controls the output current as well as the voltage, providing better transient response and protection.
- **Digital Control:** Uses microcontrollers or digital signal processors (DSPs) to manage the power supply, allowing for more sophisticated control algorithms and monitoring.

CHAPTER 2

Inverters

Dr. P. Avirajamanjula

Inverters are devices that convert direct current (DC) into alternating current (AC). They play a crucial role in various applications, including renewable energy systems, power backup solutions, and industrial processes. Here's a detailed overview of inverters, their types, operation, and applications:

Basic Operation of Inverters

1. DC to AC Conversion:

- **Function:** The primary function of an inverter is to convert DC voltage (from sources like batteries, solar panels, or fuel cells) into AC voltage, which is typically required by most household appliances, industrial equipment, and the electrical grid.

2. Components:

- **Oscillator:** Generates a high-frequency signal to drive the switching transistors.
- **Switching Devices:** Transistors (such as MOSFETs or IGBTs) that switch the DC voltage on and off to create an AC waveform.
- **Transformer (optional):** Steps up or steps down the voltage as needed. It also provides electrical isolation.
- **Filter Circuit:** Smooths out the waveform to produce a cleaner sine wave, reducing harmonic distortion.

Types of Inverters

1. Square Wave Inverters:

- **Operation:** Produce a square waveform with abrupt transitions between positive and negative voltage.
- **Applications:** Mostly used in low-power or non-sensitive applications, as the square wave can cause inefficiencies and electrical noise.

2. Modified Sine Wave Inverters:

- **Operation:** Generate a stepped approximation of a sine wave, which is better suited for most appliances compared to a square wave.
- **Applications:** Common in household appliances and some industrial equipment where a pure sine wave is not required.

3. Pure Sine Wave Inverters:

- **Operation:** Produce a smooth, continuous sine wave that closely approximates the AC power from the electrical grid.
- **Applications:** Ideal for sensitive electronics, medical equipment, and high-performance appliances that require a clean and stable power source.

4. Microinverters:

- **Operation:** Small inverters attached to individual solar panels, converting DC to AC at the panel level.
- **Applications:** Used in solar power systems to optimize energy production and improve system reliability.

5. String Inverters:

- **Operation:** Convert DC to AC from multiple solar panels connected in series (a "string").
- **Applications:** Common in residential and commercial solar power systems, offering a balance between cost and performance.

6. Central Inverters:

- **Operation:** Large inverters that handle the DC to AC conversion for entire solar arrays.

CHAPTER 3

Uncontrolled Rectifiers

Dr. P. Avirajamanjula

Uncontrolled rectifiers are electronic devices that convert alternating current (AC) to direct current (DC) without the ability to control the output voltage or current. They use passive components like diodes to perform this conversion, and their operation is typically straightforward and inexpensive. Here's a detailed overview of uncontrolled rectifiers, including their types, operation, and applications:

Basic Operation of Uncontrolled Rectifiers

1. Conversion Process:

- **Function:** The primary function of uncontrolled rectifiers is to convert AC voltage into DC voltage. This process is achieved using diodes, which allow current to flow only in one direction, effectively blocking the negative half of the AC waveform and letting only the positive half pass through.

2. Key Components:

- **Diodes:** Semiconductor devices that allow current to flow in one direction only. In uncontrolled rectifiers, diodes are used to rectify the AC input by conducting during the positive half cycles and blocking during the negative half cycles.
- **Transformers (optional):** Used in some rectifier circuits to step up or step down the AC voltage before rectification. They also provide isolation between the input and output.

3. Output Characteristics:

- **Rectified Output:** The output of an uncontrolled rectifier is a pulsating DC voltage. The waveform is not smooth and contains a ripple, which can vary depending on the type of rectifier and the load.
- **Ripple Voltage:** The AC components that remain after rectification, which can be reduced using filtering components like capacitors.

Types of Uncontrolled Rectifiers

1. Half-Wave Rectifiers:

- **Operation:** Utilizes a single diode to rectify one half of the AC waveform. During the positive half-cycle of the AC input, the diode conducts and allows current to pass, while during the negative half-cycle, the diode blocks the current.
- **Output:** Produces a pulsating DC waveform with significant ripple. The average DC output voltage is approximately 0.318 times the peak AC voltage (V_{peak}/π).
- **Applications:** Suitable for low-power applications where cost and simplicity are prioritized over performance.

2. Full-Wave Rectifiers:

- **Operation:** Uses either two diodes (center-tap transformer configuration) or four diodes (bridge rectifier configuration) to rectify both halves of the AC waveform. The result is a smoother DC output compared to a half-wave rectifier.
- **Center-Tap Transformer Configuration:** Involves a center-tap transformer and two diodes. Each diode conducts during one half-cycle of the AC input, and the center tap provides a reference for the output.
- **Bridge Rectifier Configuration:** Uses four diodes arranged in a bridge circuit to rectify both halves of the AC waveform. This method does not require a center-tap transformer and provides a higher average DC output voltage.
- **Output:** Produces a smoother pulsating DC waveform with reduced ripple compared to a half-wave rectifier. The average DC output voltage is approximately 0.637 times the peak AC voltage ($V_{\text{peak}}/2\pi$).

3. Three-Phase Rectifiers:

- **Operation:** Uses six diodes arranged in a three-phase bridge configuration to rectify a three-phase AC input. This configuration provides a more continuous and smoother DC output compared to single-phase rectifiers.
- **Output:** The DC output is smoother with less ripple and is generally more suitable for higher power applications. The average DC output voltage is approximately 1.35 times the peak phase voltage.

CHAPTER 4

Controlled Rectifiers

Dr. P. Avirajamanjula

Controlled rectifiers, unlike uncontrolled rectifiers, offer the capability to regulate and control the output voltage by adjusting the conduction angle of the rectifying devices. This makes them valuable in applications where precise control over the DC output is required. Here's a detailed overview of controlled rectifiers, including their types, operation, and applications:

Basic Operation of Controlled Rectifiers

1. DC to DC Conversion with Control:

- **Function:** Controlled rectifiers convert AC voltage to DC voltage, with the added ability to control the timing of the rectification process. This allows for regulation of the output voltage and current by varying the conduction angle of the rectifying elements.

2. Key Components:

- **Thyristors (SCRs):** The primary devices used in controlled rectifiers. Thyristors are semiconductor devices that can be triggered into conduction by a gate signal. Once conducting, they remain on until the current through them drops below a certain threshold.
- **Triggering Circuit:** A circuit used to control the gate signals applied to the thyristors, enabling precise control over their conduction angle.
- **Transformer (optional):** Provides voltage step-up or step-down and electrical isolation, similar to uncontrolled rectifiers.

3. Output Characteristics:

- **Controlled Output:** The output DC voltage can be adjusted by changing the firing angle of the thyristors. This adjustment is typically achieved through phase control, where the thyristors are triggered at a specific point in the AC cycle.

Types of Controlled Rectifiers

1. Single-Phase Controlled Rectifiers:

• Half-Wave Controlled Rectifier:

- **Operation:** Utilizes a single thyristor to rectify one half of the AC waveform. By controlling the firing angle of the thyristor, the average DC output voltage can be adjusted.
- **Applications:** Used in low-power applications where simple control is required, such as small motor drives and lighting control.

• Full-Wave Controlled Rectifier:

- **Operation:** Uses either two thyristors in a center-tap transformer configuration or four thyristors in a bridge configuration to rectify both halves of the AC waveform. The firing angles of the thyristors can be controlled to adjust the average DC output voltage.
- **Applications:** Suitable for medium-power applications, including larger motor drives and industrial heating processes.

2. Three-Phase Controlled Rectifiers:

• Three-Phase Full-Wave Controlled Rectifier:

- **Operation:** Employs six thyristors arranged in a three-phase bridge configuration to rectify a three-phase AC input. The firing angles of the thyristors are controlled to adjust the DC output voltage.
- **Applications:** Used in high-power applications such as large motor drives, industrial processes, and power supplies for electric furnaces.

CHAPTER 5

AC phase controllers

Dr. P. Avirajamanjula

AC phase controllers are devices used to control the power delivered to an AC load by adjusting the phase angle of the AC supply. They are commonly used in applications requiring variable power control, such as in lighting dimmers, motor speed controllers, and heating elements. Here's an in-depth look at AC phase controllers, including their operation, types, and applications:

Basic Operation of AC Phase Controllers

1. Phase Angle Control:

- **Function:** AC phase controllers adjust the amount of power delivered to a load by altering the phase angle at which the AC supply is turned on. By delaying the conduction of the AC waveform, the average power supplied to the load is reduced.
- **Operation:** The phase controller triggers the switching devices (usually thyristors or TRIACs) at specific points in the AC cycle. This is done by delaying the firing angle relative to the zero crossing point of the AC waveform. The longer the delay, the lower the power delivered.

2. Key Components:

- **Triggering Circuit:** Generates gate signals for the switching devices to control their conduction timing. This circuit typically includes components such as phase-locked loops (PLLs), microcontrollers, or dedicated phase control ICs.
- **Switching Devices:** Thyristors (SCRs), TRIACs, or other semiconductor devices that control the flow of current through the load based on the gate signals.
- **Load:** The component or system that receives the controlled AC power, such as a lamp, motor, or heating element.

Types of AC Phase Controllers

1. Single-Phase AC Phase Controllers:

- **TRIAC-Based Controllers:**
 - **Operation:** TRIACs are semiconductor devices that can conduct current in both directions when triggered. In a TRIAC-based phase controller, the TRIAC is turned on at a specific phase angle, allowing part of the AC waveform to pass through to the load.
 - **Applications:** Commonly used in light dimmers, fan speed controllers, and small heating elements.
- **SCR-Based Controllers:**
 - **Operation:** Similar to TRIAC-based controllers but use thyristors (SCRs), which conduct in one direction only. SCR-based controllers can be used in more demanding applications.
 - **Applications:** Used in motor speed control, heating control, and power regulation.

2. Three-Phase AC Phase Controllers:

- **Three-Phase SCR Controllers:**
 - **Operation:** Utilize six SCRs arranged in a three-phase bridge configuration to control power in three-phase AC systems. The firing angles of the SCRs are adjusted to control the power delivered to the load.
 - **Applications:** Suitable for large industrial processes, high-power motor drives, and three-phase heating systems.

CHAPTER 6

Driver and Snubber Circuits

Dr. P. Avirajamanjula

Driver Circuits

Purpose: Driver circuits are used to control the operation of power devices, such as transistors, MOSFETs, or IGBTs, which switch higher power loads. They provide the necessary voltage and current to turn these power devices on and off effectively.

Key Functions:

1. **Signal Amplification:** Drivers take a low-current control signal and amplify it to a level capable of switching the power device.
2. **Voltage Level Shifting:** Drivers can shift voltage levels to match the requirements of the power device.
3. **Current Boosting:** They provide sufficient current to quickly charge and discharge the gate or base of the power device, improving switching speed and efficiency.

Types:

- **Transistor-Based Drivers:** Simple and common, these use transistors to switch the power device.
- **Integrated Circuit (IC) Drivers:** These are dedicated driver ICs that offer high performance and additional features such as protection and timing functions.

Snubber Circuits

Purpose: Snubber circuits are used to protect switching devices from voltage spikes and transients that occur during switching. They also help in controlling the rate of voltage and current changes to prevent damage and improve reliability.

Key Functions:

1. **Absorption of Transients:** Snubbers absorb and dissipate the energy from voltage spikes or current surges, preventing damage to the switching device.
2. **Damping Oscillations:** They reduce or eliminate oscillations that can occur due to the inductance and capacitance in the circuit.
3. **Protection:** They help in protecting the power devices from excessive stress and extend their lifespan.

Types:

- **RC Snubber:** Consists of a resistor and capacitor in series. It is widely used for absorbing transient energy and damping oscillations.
- **RL Snubber:** Composed of a resistor and an inductor. It's less common but can be useful in certain applications.
- **RCD Snubber:** A combination of resistor, capacitor, and diode, designed to handle specific transient characteristics.

Designing and Implementing Driver and Snubber Circuits

1. Driver Circuit Design:

- **Voltage and Current Ratings:** Ensure the driver can handle the required voltage and current levels.
- **Switching Speed:** Choose a driver with an appropriate switching speed to match the power device's requirements.
- **Thermal Management:** Consider heat dissipation to prevent overheating.

CHAPTER 7

Buck-Boost Converters

Dr. P. Avirajamanjula

Buck-boost converters are versatile DC-DC converters that can step up (boost) or step down (buck) an input voltage to a different output voltage. They are especially useful when the input voltage can be either above or below the desired output voltage.

Types and Operation

1. Basic Operation:

- **Buck Mode:** When the input voltage is higher than the output voltage, the converter operates as a buck converter, stepping down the voltage.
- **Boost Mode:** When the input voltage is lower than the output voltage, the converter operates as a boost converter, stepping up the voltage.

2. Inverting Buck-Boost Converter:

- This type provides an output voltage that is inverted relative to the input voltage. It's commonly used when a negative voltage is needed.

3. Non-Inverting Buck-Boost Converter:

- Provides an output voltage that can be higher or lower than the input voltage, but it maintains the same polarity.

Key Components

1. Inductor:

- Stores energy and smooths out the current. Its value affects the converter's performance, including efficiency and stability.

2. Switch (Transistor):

- Controls the energy transfer to and from the inductor. It alternates between on and off states to regulate the voltage.

3. Diode:

- Provides a path for the current when the switch is off and prevents reverse current flow.

4. Capacitor:

- Smooths the output voltage by filtering out ripples and stabilizing the voltage.

5. Control Circuit:

- Regulates the switching frequency and duty cycle to maintain the desired output voltage.

Advantages

1. Flexibility:

- Can handle both step-up and step-down voltage conversions, making them adaptable to various applications.

2. Wide Input Voltage Range:

- Suitable for applications where the input voltage fluctuates above and below the desired output voltage.

3. Compact Size:

- Provides efficient voltage conversion in a small package, useful for portable or space-constrained applications.

Applications

1. Battery-Powered Devices:

- Useful in devices where the battery voltage varies but a stable output voltage is needed.

CHAPTER 8

Resonant Converters

Dr. P. Avirajamanjula

Resonant converters are a type of DC-DC converter that uses resonant circuits to achieve efficient power conversion by leveraging the natural resonant frequency of inductors and capacitors. They are known for their high efficiency and reduced electromagnetic interference.

Key Concepts

1. Resonant Circuit:

- Utilizes inductors and capacitors to create a resonant frequency. At this frequency, the impedance of the circuit is minimized, allowing for efficient energy transfer.

2. Zero Voltage Switching (ZVS) and Zero Current Switching (ZCS):

- **ZVS:** The switch turns on when the voltage across it is zero, reducing switching losses.
- **ZCS:** The switch turns off when the current through it is zero, minimizing losses during switching transitions.

Types

1. Series Resonant Converter:

- Uses a series LC circuit (inductor and capacitor in series) to achieve resonance. It's effective for applications where high efficiency is crucial.

2. Parallel Resonant Converter:

- Utilizes a parallel LC circuit (inductor and capacitor in parallel). It is often used for applications requiring a constant output voltage with varying input voltage.

3. LLC Resonant Converter:

- Combines series and parallel resonant circuits (typically uses a series inductor and a parallel capacitor). It offers high efficiency and is commonly used in power supplies for servers and high-performance computing.

Advantages

1. High Efficiency:

- Minimizes switching losses and improves overall efficiency by operating at or near the resonant frequency.

2. Reduced Electromagnetic Interference (EMI):

- Smooth switching transitions reduce EMI compared to hard-switched converters.

3. Improved Thermal Management:

- Less heat is generated due to reduced switching losses, leading to better thermal performance.

Applications

1. Power Supplies:

- High-efficiency power supplies for servers, telecom, and high-performance computing.

2. Inductive Load Drivers:

- Used in applications driving inductive loads, such as motors and transformers.

3. High-Power Applications:

- Suitable for applications requiring high power with minimal losses.

Design Considerations

1. Resonant Frequency:

- Properly design the LC circuit to achieve the desired resonant frequency for optimal performance.

2. Component Selection:

CHAPTER 9

Voltage Doubler Circuit

Dr. P. Avirajamanjula

A voltage doubler circuit is a type of DC-DC converter that increases the input voltage to a level that is approximately twice the input voltage. It is commonly used in applications where a higher voltage is required from a lower voltage source. There are two main types of voltage doubler circuits: the capacitive voltage doubler and the transformer-based voltage doubler. Each has its specific uses and design considerations.

Capacitive Voltage Doubler

Operation:

- A capacitive voltage doubler uses capacitors and diodes to achieve voltage doubling. It operates in two phases: charging and adding the voltages of the capacitors.

Types:

1. Full-Wave Capacitive Voltage Doubler:

- **Components:**
 - Two diodes
 - Two capacitors
- **Operation:**
 - During one half of the AC cycle, one capacitor charges to the peak input voltage, and the other capacitor charges to the peak input voltage minus the voltage drop of the diode.
 - During the other half of the cycle, the capacitors combine their charges to provide a voltage approximately twice the input voltage.

2. Half-Wave Capacitive Voltage Doubler:

- **Components:**
 - One diode
 - Two capacitors
- **Operation:**
 - During each half-cycle of the input waveform, one capacitor charges to the peak input voltage while the other capacitor is charged to the sum of the input voltage and the previous charge.

Applications:

- **Low-Power Applications:** Used in low-power circuits where simple and inexpensive voltage doubling is needed.
- **Signal Processing:** Often used in analog circuits where signal level needs to be increased.

Advantages:

- Simple and cost-effective for low-power applications.
- No need for inductors or transformers, which simplifies the design.

Disadvantages:

- Limited to low currents due to the capacitor charging and discharging cycles.
- Efficiency can be affected by the resistance of components and the load.

Transformer-Based Voltage Doubler

Operation:

- A transformer-based voltage doubler uses a transformer and diodes to double the voltage. This circuit is often found in AC-DC conversion applications where isolation and voltage step-up are required.

Types:

1. Full-Wave Voltage Doubler:

- **Components:**
 - A center-tap transformer
 - Two diodes
 - Two capacitors

CHAPTER 10

Capacitor Filter for Low Power Rectifiers

Dr. P. Avirajamanjula

A capacitor filter for low-power rectifiers smooths the output of a rectifier circuit, reducing the ripple voltage and providing a more stable DC output. It's commonly used in low-power applications like small power supplies and electronic circuits.

Basic Operation

1. Rectification:

- The rectifier converts AC voltage to pulsating DC voltage. In a typical full-wave rectifier circuit, the output is a series of pulses corresponding to the AC waveform's peaks.

2. Filtering:

- The capacitor filter smooths these pulses into a more constant DC voltage by charging up when the rectified voltage is high and discharging when it drops. This action reduces voltage ripple.

Design Considerations

1. Capacitor Value:

- **Larger Capacitance:** A larger capacitor value provides better smoothing and reduces ripple. For low-power applications, values ranging from 10 μ F to 1000 μ F are common.
- **Voltage Rating:** The capacitor must be rated for a voltage higher than the peak rectified voltage to ensure reliability.

2. Ripple Voltage:

- Ripple voltage is the AC component that remains after rectification. It is inversely proportional to the capacitance and the load resistance

1. Capacitor Type:

- **Electrolytic Capacitors:** Common for their high capacitance and low cost. They are suitable for most low-power rectifier applications.
- **Ceramic Capacitors:** Used for filtering high-frequency noise but are typically less effective for smoothing low-frequency ripple on their own.

Typical Configurations

1. Single Capacitor Filter:

- A single capacitor placed across the output of the rectifier. It's simple and effective for many low-power applications.

2. π -Filter:

- Consists of a capacitor-inductor-capacitor (C-L-C) arrangement. It offers better filtering by providing additional attenuation of high-frequency noise.

Applications

1. Power Supplies:

- Used in small power supplies to convert AC mains to a smooth DC output.

2. Signal Conditioning:

- Provides a stable DC voltage for sensitive electronic circuits and components.

3. Battery Chargers:

- Smooths the rectified voltage to charge batteries effectively.

Advantages

1. Simplicity:

- Easy to design and implement with minimal components.

2. Cost-Effective:

- Capacitors are inexpensive and readily available.

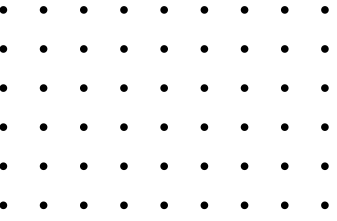

UTILIZATION AND CONSERVATION OF ELECTRICAL ENERGY

Edited by
N.MANGALESWARI



978-93-6255-165-8

Utilization and conservation of electrical energy
Copyright © 2023 by Mr.D. Hariharan

All rights reserved. No part of this book may be reproduced or transmitted in any form or by any means without written permission from the author.

ISBN: 978-93-6255-165-8

Publisher: Ponnaiyah Ramajayam Institute of Science and Technology (PRIST)
Date of Publication : 06.07.23

TABLE OF CONTENTS

| | |
|--|------------|
| Introduction | 03 |
| CHAPTER 1 - Electric drives and traction | 18 |
| Mr.D. Hariharan | |
| CHAPTER 2 - Illumination | 35 |
| Mr.D.Hariharan | |
| CHAPTER 3 - Heating and welding | 68 |
| Mr.D. Hariharan | |
| CHAPTER 4 – Energy Conservation and its importance | 115 |
| Mr.D. Hariharan | |
| CHAPTER 5 – Energy conservation of electrical energy | 138 |
| Mrs. R. Prasannadevi | |
| CHAPTER 6 – Modes of heat transfer | 142 |
| Mr.D. Hariharan | |
| CHAPTER 7 – Dielectric heating | 159 |
| Mr.D.Hariharan | |
| CHAPTER 8 – Induction heating | 164 |
| Mr.D. Hariharan | |
| CHAPTER 9 – Characteristic features of traction motor | 178 |
| Mr.D. Hariharan | |
| CHAPTER 10 – Electric braking | 194 |
| Mrs. R. Prasannadevi | |
| REFERENCES | 206 |

CHAPTER 1

Electric drives and traction

Mr.D. Hariharan

Electric Drives

Electric drives are systems used to control the operation of electric motors. They consist of an electric motor, a power supply, and a control system that regulates the motor's speed, torque, and direction. Electric drives are used in various applications, from industrial machinery to household appliances. Here's a breakdown of their components and how they work:

Components of Electric Drives:

1. Electric Motor:

- The motor converts electrical energy into mechanical energy. It can be an AC or DC motor, depending on the application.

2. Power Supply:

- Provides the electrical energy needed to drive the motor. This can be AC or DC power, and the drive system may include transformers, rectifiers, or inverters to adjust the power supply as needed.

3. Control System:

- Regulates the motor's performance by adjusting the input power. It includes:
 - **Controllers:** Manage the operation of the motor based on inputs from sensors or user settings.
 - **Feedback Systems:** Sensors (e.g., encoders, tachometers) provide real-time data on the motor's speed, position, and performance, allowing for precise control.

Types of Electric Drives:

1. DC Drives:

- **Operation:** Control the speed and torque of DC motors by varying the input voltage or current.
- **Applications:** Used in applications requiring variable speed control, such as electric vehicles and small machinery.

2. AC Drives:

- **Operation:** Control the speed and torque of AC motors by adjusting the frequency and voltage of the power supply.
- **Applications:** Common in industrial applications for controlling fans, pumps, and conveyors.

3. Variable Frequency Drives (VFDs):

- **Operation:** A type of AC drive that controls motor speed by varying the frequency of the AC power supplied to the motor.
- **Applications:** Widely used in HVAC systems, pumps, and other applications where variable speed is needed.

4. Servo Drives:

- **Operation:** Control servo motors to achieve precise position, speed, and torque control using feedback systems.
- **Applications:** Used in robotics, CNC machinery, and high-precision equipment.

5. Stepper Drives:

- **Operation:** Control stepper motors to achieve precise position control by sending pulses to the motor.
- **Applications:** Common in 3D printers, CNC machines, and automation systems.

Electric Traction

Electric traction refers to the use of electric motors to drive vehicles, typically trains, trams, or other rail vehicles. It involves the application of electric drives in transportation systems to improve efficiency, performance, and environmental impact.

CHAPTER 2

Illumination

Mr.D.Hariharan

Illumination refers to the provision of light to enhance visibility and aesthetics in various environments. It's a critical aspect of both indoor and outdoor settings, impacting safety, productivity, and ambiance. Here's an overview of the key concepts and types of illumination:

Key Concepts

- Luminous Flux (Lumens):**
 - Definition:** The total amount of visible light emitted by a source per unit of time.
 - Measurement:** Measured in lumens (lm).
- Illuminance (Lux):**
 - Definition:** The amount of light falling on a specific area. It indicates how well a surface is illuminated.
 - Measurement:** Measured in lux (lx), where 1 lux = 1 lumen/m².
- Luminance:**
 - Definition:** The intensity of light emitted from a surface in a given direction.
 - Measurement:** Measured in candelas per square meter (cd/m²).
- Color Temperature:**
 - Definition:** Describes the color appearance of light, ranging from warm (yellow) to cool (blue).
 - Measurement:** Measured in Kelvin (K). Common values include 2700K (warm white) and 6500K (daylight).
- Color Rendering Index (CRI):**
 - Definition:** Measures how accurately a light source displays colors compared to natural light.
 - Scale:** Ranges from 0 to 100, with higher values indicating better color rendering.
- Efficiency:**
 - Definition:** The effectiveness of a light source in converting electrical power into visible light.
 - Measurement:** Measured in lumens per watt (lm/W).

Types of Illumination

- General Lighting:**
 - Definition:** Provides overall illumination to a space, ensuring uniform light distribution.
 - Examples:** Ceiling-mounted fixtures, recessed lights, and LED panels.
- Task Lighting:**
 - Definition:** Focuses light on specific areas where tasks are performed to reduce eye strain and enhance visibility.
 - Examples:** Desk lamps, under-cabinet lighting in kitchens, and reading lamps.
- Accent Lighting:**
 - Definition:** Used to highlight specific objects or areas to create visual interest and emphasis.
 - Examples:** Spotlights, track lighting, and wall-mounted fixtures highlighting artwork or architectural features.
- Ambient Lighting:**
 - Definition:** Provides a base level of illumination to a space, contributing to the overall atmosphere and comfort.
 - Examples:** Overhead lights, diffused light sources, and natural daylight through windows.
- Outdoor Lighting:**
 - Definition:** Includes various lighting solutions designed for exterior environments to enhance security, aesthetics, and functionality.

CHAPTER 3

Heating and welding

Mr.D. Hariharan

Heating and welding are fundamental processes used in various industrial and manufacturing applications. Here's an overview of both:

Heating

Heating involves raising the temperature of a material to achieve a desired effect, such as altering its properties, preparing it for further processing, or ensuring proper operation. Common methods of heating include:

1. Electric Heating:

- **Resistive Heating:** Uses electrical resistance to generate heat. Commonly used in heating elements like toasters and industrial furnaces.
- **Induction Heating:** Uses electromagnetic induction to heat conductive materials. Common in metal processing and hardening.

2. Gas Heating:

- **Burners:** Combustion of gases like natural gas or propane generates heat. Used in industrial ovens, furnaces, and heating systems.

3. Infrared Heating:

- **Infrared Emitters:** Radiate heat directly to the object, warming it without heating the surrounding air. Used in drying, curing, and some heating applications.

4. Microwave Heating:

- **Microwave Ovens:** Use microwave radiation to heat materials. Common in cooking and industrial processes that require precise heating.

5. Hot Air Heating:

- **Air Heaters:** Use hot air blown over or around the material. Used in drying and some industrial applications.

Welding

Welding is a fabrication process used to join materials, usually metals or thermoplastics, by causing coalescence. This is typically achieved by melting the materials at the joining surfaces and often using a filler material. Here are some common welding methods:

1. Arc Welding:

- **Process:** Uses an electric arc to generate heat between an electrode and the workpiece. Common methods include:
 - **Shielded Metal Arc Welding (SMAW):** Uses a consumable electrode coated in flux to protect the weld pool from contamination.
 - **Gas Tungsten Arc Welding (GTAW/TIG):** Uses a tungsten electrode to produce the weld, with a separate filler material if needed.
 - **Gas Metal Arc Welding (GMAW/MIG):** Uses a continuous wire electrode and a shielding gas to protect the weld area.

2. Gas Welding:

- **Process:** Uses the heat of a gas flame, typically acetylene and oxygen, to melt the workpieces and fuse them together.
- **Applications:** Common in welding thin materials and for repair work.

3. Resistance Welding:

- **Process:** Applies pressure and passes an electric current through the workpieces to create heat at the interface. Methods include:
 - **Spot Welding:** Joins two or more overlapping metal sheets at specific points.
 - **Seam Welding:** Joins metal sheets in a continuous seam.

CHAPTER 4

Energy Conservation and its importance

Mr.D. Hariharan

Energy conservation refers to the practice of using less energy by implementing strategies that reduce energy consumption and increase efficiency. It involves adopting technologies and practices that lead to the more efficient use of energy resources, thereby minimizing waste. The importance of energy conservation can be understood from various perspectives:

Importance of Energy Conservation

1. Environmental Benefits:

- **Reduction in Greenhouse Gas Emissions:** Conserving energy reduces the amount of fuel needed for energy production, which decreases greenhouse gas emissions and helps mitigate climate change.
- **Lower Air Pollution:** Reduced energy consumption leads to decreased emissions of pollutants such as sulfur dioxide (SO₂) and nitrogen oxides (NO_x), which are harmful to human health and the environment.
- **Preservation of Natural Resources:** By using energy more efficiently, we decrease the demand for finite natural resources like fossil fuels, helping to preserve them for future generations.

2. Economic Benefits:

- **Cost Savings:** Implementing energy-efficient technologies and practices reduces energy bills for businesses and households. This can lead to significant financial savings over time.
- **Job Creation:** The energy conservation sector can create jobs related to energy audits, retrofitting buildings, and developing new technologies.
- **Economic Stability:** Reducing energy consumption can help stabilize energy prices by decreasing demand and mitigating the impact of energy price fluctuations.

3. Enhanced Energy Security:

- **Reduced Dependence on Imports:** Energy conservation decreases the need for imported fuels, which enhances national energy security and reduces vulnerability to geopolitical and economic uncertainties.
- **Improved Resilience:** By using energy more efficiently and diversifying energy sources, nations and organizations can better withstand energy supply disruptions.

4. Increased Efficiency:

- **Optimized Resource Use:** Energy conservation leads to more efficient use of energy resources, which can improve the overall performance and reliability of energy systems.
- **Extended Lifespan of Infrastructure:** Efficient use of energy can reduce wear and tear on infrastructure, extending the lifespan of energy systems and reducing maintenance costs.

5. Health and Comfort:

- **Improved Indoor Air Quality:** Energy-efficient building practices, such as proper insulation and ventilation, can improve indoor air quality and create healthier living and working environments.
- **Enhanced Comfort:** Efficient heating, cooling, and lighting systems can contribute to a more comfortable and pleasant living environment.

Strategies for Energy Conservation

1. Building and Home Efficiency:

- **Insulation and Weatherization:** Improve insulation and seal leaks to reduce heating and cooling needs.
- **Energy-Efficient Windows and Doors:** Install windows and doors with better insulating properties to minimize energy loss.
- **Smart Thermostats:** Use programmable or smart thermostats to optimize heating and cooling schedules.

CHAPTER 5

Energy conservation of electrical energy

Mrs. R. Prasannadevi

Energy conservation in the context of electrical energy focuses on reducing energy consumption and improving the efficiency of electrical systems and devices. By implementing various strategies, individuals, businesses, and organizations can lower their energy bills, reduce their environmental impact, and enhance the overall efficiency of electrical systems. Here's a comprehensive guide on how to achieve electrical energy conservation:

1. Energy-Efficient Lighting

- **Switch to LED Bulbs:**
 - **Benefits:** LEDs use up to 80% less energy compared to incandescent bulbs and have a longer lifespan.
 - **Application:** Replace incandescent and CFL bulbs with LED bulbs in homes, offices, and industrial settings.
- **Use Lighting Controls:**
 - **Dimmers:** Adjust light levels to reduce energy use when full brightness is not necessary.
 - **Timers and Sensors:** Install timers and motion sensors to ensure lights are only on when needed.
- **Maximize Natural Light:**
 - **Daylighting:** Use natural light by installing skylights, light tubes, or larger windows to reduce the need for artificial lighting.

2. Efficient Heating, Ventilation, and Air Conditioning (HVAC)

- **Upgrade to Energy-Efficient Systems:**
 - **HVAC Systems:** Choose high-efficiency HVAC systems with ENERGY STAR ratings to reduce energy consumption.
 - **Heat Pumps:** Consider using heat pumps for both heating and cooling, which can be more efficient than traditional systems.
- **Regular Maintenance:**
 - **Filters:** Replace or clean air filters regularly to ensure efficient operation.
 - **Inspections:** Schedule regular inspections and maintenance for HVAC systems to keep them running efficiently.
- **Programmable Thermostats:**
 - **Smart Thermostats:** Use programmable or smart thermostats to optimize heating and cooling schedules based on occupancy and usage patterns.

3. Efficient Appliances and Equipment

- **Energy-Efficient Appliances:**
 - **Energy Star Ratings:** Purchase appliances with ENERGY STAR ratings, which are designed to use less energy.
 - **Smart Appliances:** Use appliances with smart features that can be controlled remotely or programmed to run during off-peak hours.
- **Power Management:**
 - **Power Strips:** Use smart power strips to prevent energy waste from electronics that consume power even when turned off.
 - **Energy-Saving Modes:** Activate energy-saving modes on devices like computers, printers, and other office equipment.

CHAPTER 6

Modes of heat transfer

Mr.D. Hariharan

Heat transfer occurs through three primary modes: **conduction**, **convection**, and **radiation**. Each mode operates based on different principles and is applicable in various scenarios.

1. Conduction

Conduction is the transfer of heat through a solid material or between materials in direct contact. Heat moves from the hotter region to the cooler region due to the vibration and movement of particles.

- **Principle:** Heat is transferred through direct molecular interaction. High-energy (hot) molecules transfer their energy to adjacent lower-energy (cooler) molecules.
- **Examples:** Cooking with a metal pan on a stove, heat traveling through a metal rod.

Key Factors:

- **Thermal Conductivity:** Materials with high thermal conductivity (like metals) transfer heat more effectively than those with low thermal conductivity (like insulators).
- **Temperature Gradient:** The rate of heat transfer is proportional to the temperature difference between the two regions.

2. Convection

Convection is the transfer of heat between a surface and a fluid (liquid or gas) in motion. It involves the bulk movement of the fluid which carries heat with it.

- **Principle:** Heat is transferred by the movement of fluid molecules. Warmer fluid expands, becomes less dense, and rises, while cooler fluid descends, creating a convective current.
- **Examples:** Boiling water, atmospheric weather patterns, air heating in a room.

Types:

- **Natural Convection:** Occurs due to natural buoyancy forces (e.g., warm air rising naturally).
- **Forced Convection:** Occurs when an external force, such as a fan or pump, moves the fluid (e.g., a fan in a computer cooling system).

Key Factors:

- **Fluid Properties:** Density, viscosity, and thermal conductivity of the fluid affect convection.
- **Flow Rate:** Higher flow rates enhance heat transfer.

3. Radiation

Radiation is the transfer of heat through electromagnetic waves. It does not require a medium and can occur through a vacuum.

- **Principle:** Heat is transferred through electromagnetic radiation, typically infrared radiation. All objects emit radiation depending on their temperature.
- **Examples:** Sunlight warming the Earth, heat emitted from a fireplace.

Key Factors:

- **Temperature:** The amount of radiated heat increases with the temperature of the object.
- **Surface Characteristics:** Emissivity of the surface affects how well it radiates heat (e.g., shiny surfaces emit less radiation compared to dull, dark surfaces).
- **Distance:** The intensity of radiation decreases with the square of the distance from the source.

Summary

- **Conduction:** Heat transfer through direct contact within or between solids. Depends on material properties and temperature gradients.
- **Convection:** Heat transfer through fluid motion, either natural or forced. Depends on fluid properties and flow dynamics.
- **Radiation:** Heat transfer through electromagnetic waves. Does not require a medium and depends on the temperature and emissivity of the radiating surface.

CHAPTER 7

Dielectric heating

Mr.D.Hariharan

Dielectric heating is a process where heat is generated by the rapid oscillation of electric fields within a dielectric material. This process is commonly used in industrial and commercial applications for heating, drying, and processing materials.

Principle of Dielectric Heating

1. Electric Field Interaction:

- Dielectric heating involves applying an alternating electric field to a dielectric material (an insulating material that does not conduct electricity). The electric field causes the polarization of the material's molecules.

2. Molecular Vibration:

- As the electric field oscillates, it causes the dipole molecules within the dielectric material to align with the field, which results in frictional heating due to the continuous reorientation of these dipoles. This molecular friction generates heat within the material.

3. Energy Absorption:

- The dielectric material absorbs energy from the electric field, which is converted into heat. This heating occurs internally, allowing for uniform temperature distribution and efficient heating.

Applications of Dielectric Heating

1. Industrial Heating:

- **Microwave Heating:** Used in processes such as drying, curing, and heating materials like ceramics, plastics, and food products. Microwaves operate at frequencies typically around 2.45 GHz.
- **Radio Frequency Heating:** Used for processes like bonding, curing, and drying, especially in the textile and paper industries. Radio frequency heating operates at frequencies typically between 3 MHz and 300 MHz.

2. Food Processing:

- **Microwave Ovens:** Commonly used in households and commercial kitchens for cooking and reheating food. Microwaves generate dielectric heating by causing water molecules in the food to vibrate, generating heat.

3. Medical Treatments:

- **Diathermy:** Utilizes high-frequency electromagnetic fields to generate heat within tissues for therapeutic purposes, such as pain relief and muscle relaxation.

Advantages of Dielectric Heating

1. Uniform Heating:

- Provides uniform heating throughout the material due to internal heating, reducing temperature gradients and avoiding hot spots.

2. Energy Efficiency:

- High efficiency due to direct energy absorption by the material, resulting in faster heating compared to conventional methods.

3. Selective Heating:

- Can selectively heat certain materials based on their dielectric properties, allowing for precise control in processing.

4. Non-Contact Heating:

- Allows for heating without direct contact, reducing the risk of contamination and wear on heating elements.

CHAPTER 8

Induction heating

Mr.D. Hariharan

Induction heating is a process of heating electrically conductive materials by inducing electric currents within them using electromagnetic fields. This method is widely used in various industrial applications for its efficiency, precision, and control.

Principle of Induction Heating

1. Electromagnetic Induction:

- Induction heating relies on Faraday's Law of Induction, which states that a changing magnetic field induces an electric current in a conductor. When an alternating current (AC) passes through an induction coil (a conductive loop), it creates a rapidly changing magnetic field around it.

2. Induced Currents:

- This changing magnetic field penetrates the conductive material placed inside or near the coil, inducing eddy currents within the material. These eddy currents generate heat due to the material's electrical resistance, which raises its temperature.

3. Heating Effect:

- The heat is generated directly within the material, leading to efficient and localized heating. The depth of heating can be controlled by adjusting the frequency of the AC and the characteristics of the coil.

Components of an Induction Heating System

1. Induction Coil:

- The coil, also known as the inductor, is the component through which the AC passes to generate the alternating magnetic field. The shape and design of the coil are tailored to the specific application and the shape of the material being heated.

2. Power Supply:

- An induction heating system uses an alternating current power supply to create the magnetic field. The power supply converts the incoming electrical power to the frequency and voltage required for induction heating.

3. Workpiece:

- The material or object being heated. It must be electrically conductive for induction heating to be effective. The workpiece is placed within the induction coil where it experiences the magnetic field and induced currents.

Applications of Induction Heating

1. Metal Heating:

- **Hardening:** Induction heating is commonly used for hardening the surface of metals. The rapid heating followed by quick cooling increases the hardness of the metal surface.
- **Annealing:** This process involves heating a metal to a specific temperature and then cooling it slowly to relieve internal stresses and improve ductility.
- **Forging:** Induction heating is used to heat metal billets to a high temperature for forging operations.

2. Brazing and Soldering:

- **Brazing:** Induction heating is used to heat metal parts and filler materials to form a strong bond without melting the base metals.
- **Soldering:** Similar to brazing, but at lower temperatures, induction heating is used to join electronic components or metal parts.

CHAPTER 9

Characteristic features of traction motor

Mr.D. Hariharan

Traction motors are specialized electric motors used to drive the wheels of vehicles, such as trains, trams, and electric buses. They are designed to provide the necessary power and control for moving these vehicles efficiently. Here are the characteristic features of traction motors:

1. High Torque at Low Speeds

- **Key Feature:** Traction motors are designed to deliver high torque even at low speeds. This is essential for starting and accelerating heavy vehicles, such as trains or electric buses, from a standstill.
- **Why It Matters:** High torque at low speeds ensures effective traction and helps in overcoming the inertia of the vehicle.

2. Robust Construction

- **Key Feature:** Traction motors are built to withstand harsh operating conditions, including high mechanical stresses and environmental factors like dust, moisture, and temperature extremes.
- **Why It Matters:** Durability and reliability are crucial for the continuous and safe operation of transportation systems.

3. High Efficiency

- **Key Feature:** These motors are designed for high efficiency to maximize energy use and minimize losses. They often incorporate features like regenerative braking to recover energy during braking.
- **Why It Matters:** Efficient motors contribute to lower operating costs and better energy utilization.

4. Variable Speed Operation

- **Key Feature:** Traction motors can operate over a wide range of speeds, from very low to high speeds, allowing for smooth acceleration and deceleration.
- **Why It Matters:** Variable speed capability is important for the dynamic requirements of transportation systems, including starting, stopping, and maintaining cruising speeds.

5. Thermal Management

- **Key Feature:** Effective thermal management systems are integrated to handle the heat generated during operation, including cooling systems to maintain optimal operating temperatures.
- **Why It Matters:** Proper cooling prevents overheating and ensures consistent performance and longevity of the motor.

6. Control and Regeneration

- **Key Feature:** Traction motors often feature sophisticated control systems that allow for precise speed and torque control. Many systems also support regenerative braking, where the motor acts as a generator to convert kinetic energy back into electrical energy.
- **Why It Matters:** Advanced control and regeneration improve overall efficiency and performance, and help in energy recovery and management.

7. Adaptability to Different Power Sources

- **Key Feature:** Traction motors can be designed to operate with various power sources, including electric grids, batteries, or onboard power systems.
- **Why It Matters:** Adaptability allows for flexibility in different transportation applications, such as electric trains, hybrid vehicles, and battery-powered buses.

8. High Starting Capability

- **Key Feature:** The motor is capable of handling high starting currents and provides sufficient starting torque to initiate movement.
- **Why It Matters:** High starting capability is essential for getting heavy vehicles moving from a stationary position.

CHAPTER 10

Electric braking

Mrs. R. Prasannadevi

Electric braking is a method of slowing down or stopping an electric motor or vehicle using electrical means rather than mechanical systems. This technique is often used in electric and hybrid vehicles, trains, and other systems where precise control and energy efficiency are important. There are several types of electric braking, each with distinct mechanisms and advantages.

1. Regenerative Braking

Regenerative Braking converts the kinetic energy of the vehicle back into electrical energy during braking and stores it for future use.

- **Mechanism:** During braking, the electric motor reverses its role and acts as a generator. The kinetic energy of the vehicle is converted into electrical energy, which is then fed back into the battery or power supply.
- **Advantages:** Increases overall energy efficiency and extends the range of electric vehicles by recovering and reusing energy.
- **Applications:** Commonly used in electric vehicles, trains, and trams.

2. Dynamic Braking

Dynamic Braking involves converting the kinetic energy of the vehicle into heat by using resistors.

- **Mechanism:** When braking, the electric motor operates in generator mode, but instead of feeding the generated energy back into the battery, it is dissipated as heat through external resistors.
- **Advantages:** Provides effective braking without relying on mechanical components, and is simpler in systems where energy recovery is not needed.
- **Applications:** Often used in electric trains and some industrial applications.

3. Eddy Current Braking

Eddy Current Braking uses magnetic fields to create resistive forces that slow down the motion of a conductive material.

- **Mechanism:** A magnetic field is applied to a rotating conductive material, inducing eddy currents within it. These eddy currents generate resistive forces that oppose the rotation and produce braking.
- **Advantages:** Provides smooth, contactless braking with minimal wear and maintenance, and can be used in conjunction with other braking methods.
- **Applications:** Used in some high-speed trains, amusement park rides, and industrial machinery.

4. Electromagnetic Braking

Electromagnetic Braking involves using electromagnetic forces to create braking action.

- **Mechanism:** Electromagnets generate forces that act on a conductive or ferromagnetic material to create braking. This can be achieved through electromagnetic attraction or repulsion.
- **Advantages:** Provides reliable and precise braking control without physical contact, reducing wear and tear.
- **Applications:** Used in certain railways, elevators, and industrial systems.

5. Electric Motor Braking

Electric Motor Braking involves using the motor's electrical characteristics to provide braking force.

- **Mechanism:** By adjusting the motor's current or voltage, or by using methods such as field weakening, the braking force is created. For instance, in field-weakening braking, the motor's magnetic field is reduced to decrease its torque.
- **Advantages:** Provides smooth and controlled braking directly through the motor's control system.



ELECTRICAL MACHINES II

EDITED BY

R. PRASANNADEVI



978-93-6255-486-4

Electrical Machines II
Copyright © 2023 by Mrs. R. Prasannadevi

All rights reserved. No part of this book may be reproduced or transmitted in any form or by any means without written permission from the author.

ISBN: 978-93-6255-486-4

Publisher: Ponnaiyah Ramajayam Institute of Science and Technology (PRIST)
Date of Publication : 22.6.23

TABLE OF CONTENTS

| | |
|--|------------|
| Introduction | 07 |
| CHAPTER 1 - Synchronous generator | 21 |
| Mrs.R.Nagalakshmi | |
| CHAPTER 2 - Synchronous motor | 40 |
| Mrs.N.Mangaleswari | |
| CHAPTER 3 - Three phase induction motor | 81 |
| Mr.D.Hariharan | |
| CHAPTER 4 – Speed control of Induction motor | 125 |
| Mrs.R.Nagalakshmi | |
| CHAPTER 5 – Special machines and single phase motor | 148 |
| Mrs.R.Nagalakshmi | |
| CHAPTER 6 – Synchronous Condenser | 156 |
| Mrs.R.Nagalakshmi | |
| CHAPTER 7 – Single Phase Induction Motor | 167 |
| Mrs.N.Mangaleswari | |
| CHAPTER 8 – Synchronous Induction Motor | 182 |
| Mr.D.Hariharan | |
| CHAPTER 9 – Parallel Operation and Load Sharing | 197 |
| Mrs.R.Nagalakshmi | |
| CHAPTER 10 – Regulation of Salient Pole Alternators | 206 |
| Mrs.R.Nagalakshmi | |
| REFERENCES | 217 |

CHAPTER 1

Synchronous generator

Mrs.R.Nagalakshmi

Synchronous Generator

A synchronous generator, also known as an alternator, is a type of electrical machine that converts mechanical energy into electrical energy using electromagnetic induction. It operates at synchronous speed, which is directly related to the frequency of the generated AC voltage. Synchronous generators are widely used in power plants and industrial applications for their reliability and ability to maintain a constant frequency and voltage.

1. Principle of Operation

1.1 Electromagnetic Induction

A synchronous generator operates on the principle of electromagnetic induction. When a rotating magnetic field (produced by the rotor) passes through the stator windings, it induces an alternating voltage in the stator coils.

1.2 Synchronous Speed

The synchronous speed of a generator is the speed at which the rotating magnetic field (produced by the rotor) and the rotating magnetic field of the stator (induced by the rotor) synchronize. It is determined by the frequency of the AC power system and the number of poles in the generator.

Formula for Synchronous Speed (N_s): N_s

2. Construction

2.1 Rotor

The rotor is the rotating part of the generator and consists of a set of electromagnetic poles. It can be either:

- **Salient Pole Rotor:** Used in low-speed generators, characterized by protruding poles.
- **Cylindrical Rotor (Turbo Rotor):** Used in high-speed generators, characterized by a smooth, cylindrical surface.

2.2 Stator

The stator is the stationary part of the generator and contains the armature windings where the AC voltage is induced. The stator is made of laminated steel to reduce eddy current losses.

2.3 Field Windings

The rotor has field windings that are energized by a DC source, creating a magnetic field. This magnetic field rotates with the rotor and induces an AC voltage in the stator windings.

3. Operation and Performance

3.1 Excitation System

The excitation system provides the DC current to the rotor windings, creating the magnetic field necessary for inducing voltage in the stator windings. It can be:

- **Static Excitation:** Uses rectifiers to convert AC to DC for the rotor windings.
- **Rotating Exciter:** A small AC generator mounted on the same shaft as the main generator, providing DC excitation to the rotor.

3.2 Voltage Regulation

Synchronous generators are equipped with automatic voltage regulators (AVRs) to maintain a constant output voltage. The AVR adjusts the excitation current based on the load and system conditions.

CHAPTER 2

Synchronous motor

Mrs.N.Mangaleswari

Synchronous Motor

A synchronous motor is an AC motor that operates at synchronous speed, which is the speed at which the rotating magnetic field of the stator synchronizes with the rotational speed of the rotor. This synchronization allows the motor to maintain a constant speed regardless of the load, as long as the voltage and frequency remain stable.

1. Principle of Operation

1.1 Electromagnetic Induction

A synchronous motor operates on the principle of electromagnetic induction. It converts electrical energy into mechanical energy using a rotating magnetic field created by the stator and a magnetic field from the rotor.

1.2 Synchronous Speed

The synchronous speed (N_s) of the motor is the speed at which the rotating magnetic field of the stator and the rotor magnetic field are in sync.

2. Construction

2.1 Stator

- **Stator Windings:** The stator has three-phase windings, which are connected to the AC power supply. These windings create a rotating magnetic field.
- **Core:** The stator core is made of laminated sheets to reduce eddy current losses and is designed to enhance the efficiency of the magnetic field.

2.2 Rotor

- **Salient Pole Rotor:** Commonly used in low-speed applications, featuring projecting poles.
- **Cylindrical Rotor:** Used in high-speed applications, characterized by a smooth surface.
- **Field Windings:** The rotor contains windings that are energized with DC current, creating a magnetic field.

3. Operation

3.1 Starting

Synchronous motors require a separate starting mechanism because they cannot start on their own. Typical starting methods include:

- **Use of an Auxiliary Motor:** An external motor is used to bring the synchronous motor up to near synchronous speed.
- **Rotor Excitation:** In some designs, the rotor excitation is applied only after the motor has reached near synchronous speed.

3.2 Synchronization

Once the motor reaches synchronous speed, the DC excitation is applied to the rotor windings. The rotor's magnetic field aligns with the rotating magnetic field of the stator, and the motor runs synchronously with the supply frequency.

3.3 Power Factor Control

Synchronous motors can be used to improve the power factor of the power system. By adjusting the rotor excitation, the motor can operate with a leading or lagging power factor.

CHAPTER 3

Three phase induction motor

Mr.D.Hariharan

A three-phase induction motor is a type of electric motor that operates on a three-phase AC power supply. It is one of the most commonly used types of motors in industrial and commercial applications due to its simplicity, reliability, and efficiency. Here's a brief overview of its key components and operation:

Components:

1. Stator:

- The stator is the stationary part of the motor and contains the three-phase winding. When three-phase AC current flows through these windings, it creates a rotating magnetic field.

2. Rotor:

- The rotor is the rotating part inside the stator. There are two main types of rotors:
 - **Squirrel Cage Rotor:** This is the most common type and consists of a series of conductive bars shorted at both ends by end rings, resembling a squirrel cage.
 - **Wound Rotor:** This type has windings on the rotor itself, which are connected to external resistors or control systems.

3. Bearings:

- Bearings support the rotor and allow it to rotate smoothly within the stator.

4. End Bells:

- These are covers that protect the motor and house the bearings.

Operation:

1. Magnetic Field Creation:

- When three-phase AC power is applied to the stator windings, it creates a rotating magnetic field that travels around the stator.

2. Induction Process:

- The rotating magnetic field induces a current in the rotor due to electromagnetic induction. This induced current generates its own magnetic field, which interacts with the stator's magnetic field.

3. Torque Production:

- The interaction between the magnetic fields of the stator and rotor produces torque, causing the rotor to turn. The rotor tries to catch up with the rotating magnetic field, but it always lags behind, which is essential for producing torque.

4. Slip:

- The difference in speed between the rotating magnetic field (synchronous speed) and the rotor speed is known as "slip." Slip is necessary for torque generation.



CHAPTER 4

Speed control of Induction motor

Mrs.R.Nagalakshmi

Speed Control of Induction Motors

Induction motors are widely used in industrial and commercial applications due to their robustness, reliability, and cost-effectiveness. However, controlling their speed is essential for many applications, and various methods are available to achieve this. Speed control of induction motors can be broadly classified into methods that alter the stator voltage, frequency, or rotor resistance.

1. Speed Control Methods

1.1 Voltage Control

1.1.1 Variable Voltage Control

- **Description:** Adjusting the voltage supplied to the motor changes the torque produced, which indirectly affects the speed. Lowering the voltage reduces the motor's speed, while increasing the voltage raises the speed.
- **Application:** Suitable for applications where precise speed control is not critical. Typically used with induction motors running on constant load conditions.
- **Method:** Use of transformers or autotransformers to vary the input voltage.

1.1.2 Tap-Changer Transformers

- **Description:** Tap changers on transformers allow for the adjustment of the voltage supplied to the motor. This method is used for coarse speed control.
- **Application:** Used in situations where only a few speed settings are needed.

1.2 Frequency Control

1.2.1 Variable Frequency Drive (VFD)

- **Description:** A VFD adjusts the frequency of the AC supply to the motor, which directly changes the synchronous speed and, consequently, the speed of the induction motor. The relationship between speed and frequency is given by: $N = \frac{120 \cdot f}{P}$ Where N is the speed in RPM, f is the frequency, and P is the number of poles.
- **Application:** Provides precise speed control and is widely used in various applications such as fans, pumps, and conveyors.

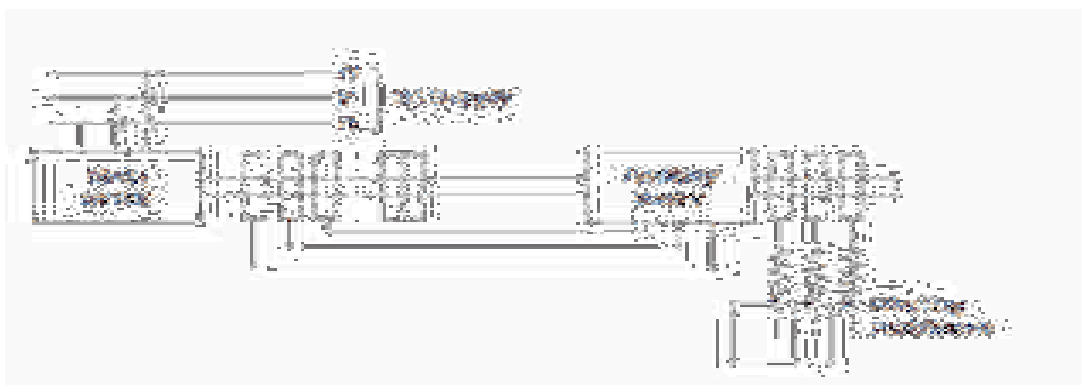

CHAPTER 5

Special machines and single phase motor

Mrs.R.Nagalakshmi

Special Machines

Special machines refer to types of electrical machines designed for specific applications that do not fit the standard categories of motors and generators. Here are a few notable examples:

1. Stepper Motors:

- **Operation:** Stepper motors divide a full rotation into a large number of steps, allowing for precise control of position. They are driven by pulse signals and can maintain their position without feedback systems.
- **Applications:** Used in applications requiring precise control, such as 3D printers, CNC machines, and robotics.

2. Servo Motors:

- **Operation:** Servo motors are designed for precise control of angular or linear position, velocity, and acceleration. They typically use a feedback system to ensure accurate performance.
- **Applications:** Commonly used in robotics, automation, and CNC machinery for high-precision tasks.

3. Linear Motors:

- **Operation:** Linear motors produce linear motion directly, rather than rotational motion. They have a flat, linear stator and rotor arrangement.
- **Applications:** Used in applications requiring linear motion, such as maglev trains, automated assembly lines, and actuators in various machines.

4. Universal Motors:

- **Operation:** Universal motors can operate on either AC or DC power and have a design that allows them to run efficiently on both types of current.
- **Applications:** Often found in household appliances like vacuum cleaners and power tools.

5. Hysteresis Motors:

- **Operation:** Hysteresis motors use the hysteresis effect of magnetic materials to create torque. They have a rotor made of a magnetic material that retains magnetization.
- **Applications:** Used in applications requiring smooth and quiet operation, such as clocks and small fans.

6. Reluctance Motors:

- **Operation:** Reluctance motors operate on the principle of reluctance, where the rotor moves to the position of minimum reluctance in the stator's magnetic field.
- **Applications:** Used in various industrial applications and in some high-performance drives.

Single-Phase Motors

Single-phase motors are designed to operate on single-phase AC power, which is common in residential and small commercial settings. Here are the main types of single-phase motors:

1. Split-Phase Motor:

- **Operation:** Uses two windings – a start winding and a run winding. The start winding is energized during startup to provide initial torque, while the run winding takes over once the motor reaches a certain speed.
- **Applications:** Suitable for small appliances and tools such as fans and small pumps.

2. Capacitor-Start Motor:

- **Operation:** Similar to the split-phase motor, but with the addition of a capacitor in series with the start winding. This provides a higher starting torque.
- **Applications:** Commonly used in applications requiring higher starting torque, such as compressors and some pumps.

CHAPTER 6

Synchronous Condenser

Mrs.R.Nagalakshmi

A **Synchronous Condenser** is a type of synchronous machine used primarily for reactive power compensation in electrical power systems. It operates similarly to a synchronous generator but is typically used to improve the power factor and stabilize the voltage in power grids rather than to generate power.

Key Characteristics and Functions

1. **Reactive Power Compensation:**

- A synchronous condenser can absorb or supply reactive power to the electrical grid. This ability helps in controlling voltage levels and improving the power factor of the system.
- When operating in overexcited mode, it supplies reactive power (acting as a capacitor). When operating in underexcited mode, it absorbs reactive power (acting as an inductor).

2. **Voltage Regulation:**

- It helps in maintaining voltage levels within desired limits by adjusting the reactive power provided to or absorbed from the system.

3. **Power Factor Correction:**

- It improves the power factor of the system by providing or absorbing reactive power, thus reducing the phase difference between the voltage and current.

4. **Stability Enhancement:**

- It enhances the stability of the power system by supporting the system during voltage dips or disturbances and helping in the restoration of voltage levels.

Operating Principle

1. **Synchronous Machine Operation:**

- A synchronous condenser is essentially a synchronous motor without a mechanical load. Its rotor is driven by an external source (often the grid itself) and runs at synchronous speed.
- The excitation of the machine (field current) determines whether it acts as a source or sink of reactive power.

2. **Excitation Control:**

- By adjusting the excitation current (field current) of the synchronous condenser, the machine can be operated in different modes:
 - **Overexcited Mode:** The machine supplies reactive power (acts as a capacitor).
 - **Underexcited Mode:** The machine absorbs reactive power (acts as an inductor).

Applications

1. **Voltage Support in Transmission Networks:**

- Synchronous condensers are used in transmission networks to provide voltage support and stabilize voltage levels over long transmission lines.

2. **Power Factor Correction:**

- They are employed in industrial plants and large electrical systems to correct the power factor and reduce the penalties associated with poor power factor.

3. **Dynamic Voltage Support:**

- They can provide dynamic voltage support during sudden changes in load or system disturbances, improving system reliability and stability.

Comparison with Capacitor Banks

- **Capacitor Banks:** Provide reactive power compensation through fixed or variable capacitor units. They are simpler and more cost-effective but lack the dynamic response capabilities of synchronous condensers.

CHAPTER 7

Single Phase Induction Motor

Mrs.N.Mangaleswari

A **Single-Phase Induction Motor** is a type of electric motor commonly used in household appliances, small machinery, and various other applications where a single-phase AC power supply is available. Unlike three-phase motors, which are more commonly used in industrial settings due to their efficiency and power, single-phase induction motors are designed to operate on single-phase AC power, which is typically used in residential and light commercial settings.

Key Characteristics

1. Single-Phase Operation:

- **Power Supply:** Operates on a single-phase AC supply. The single-phase power supply is typical in residential settings and many small commercial applications.
- **Starting Mechanism:** Unlike three-phase motors, single-phase induction motors require a mechanism to start, as a single-phase supply alone cannot create a rotating magnetic field.

2. Induction Principle:

- **Operation:** Single-phase induction motors operate on the principle of electromagnetic induction, where a rotating magnetic field is produced by the interaction of the stator windings and the rotor.
- **Stator and Rotor:** The stator consists of the primary windings connected to the AC power supply, while the rotor, typically a squirrel-cage type, is placed within the stator.

Types of Single-Phase Induction Motors

1. Split-Phase Motor:

- **Starting Mechanism:** Uses a starting winding and a centrifugal switch or relay to disconnect the starting winding once the motor reaches a certain speed.
- **Characteristics:** Provides good starting torque and is commonly used in applications such as fans and small pumps.
- **Advantages:** Simple construction and relatively low cost.
- **Disadvantages:** Lower efficiency compared to other types, and starting torque is limited.

2. Capacitor-Start Motor:

- **Starting Mechanism:** Uses a capacitor in series with the starting winding to improve starting torque. The capacitor is disconnected by a centrifugal switch once the motor reaches operating speed.
- **Characteristics:** Provides higher starting torque compared to split-phase motors and is used in applications requiring higher starting loads.
- **Advantages:** Better starting performance and higher efficiency compared to split-phase motors.
- **Disadvantages:** More complex construction and higher cost due to the inclusion of a capacitor.

3. Capacitor-Start, Capacitor-Run Motor:

- **Starting and Running Mechanism:** Uses capacitors for both starting and running, which helps improve performance over a wide range of speeds.
- **Characteristics:** Provides good starting torque and efficient operation throughout the running speed range.
- **Advantages:** High efficiency and good running performance.
- **Disadvantages:** More expensive and complex due to the additional capacitors.

CHAPTER 8

Synchronous Induction Motor

Mr.D.Hariharan

The term **Synchronous Induction Motor** might be confusing as it combines elements of both synchronous motors and induction motors, which are fundamentally different types of electrical machines. However, I'll clarify the concepts of synchronous motors and induction motors separately and explain if there is any overlap or confusion in terminology.

Synchronous Motor

A **synchronous motor** is an AC motor that operates at synchronous speed, which is the speed of the rotating magnetic field produced by the stator.

1. Operation Principle:

- **Synchronous Speed:** The rotor of a synchronous motor rotates at the same speed as the rotating magnetic field produced by the stator, which is determined by the frequency of the AC supply and the number of poles in the stator.
- **Magnetic Field:** The rotor is energized with DC current, creating a constant magnetic field that locks in with the rotating magnetic field of the stator.

2. Key Characteristics:

- **Constant Speed:** The motor runs at a constant speed regardless of the load.
- **Power Factor:** Can be adjusted to either lead or lag, helping in power factor correction.
- **No Slip:** Unlike induction motors, synchronous motors do not experience slip (the difference between synchronous speed and rotor speed).

3. Applications:

- Used in applications requiring precise speed control and power factor correction, such as large industrial drives and power factor correction equipment.

Induction Motor

An **induction motor** (or asynchronous motor) is the most common type of AC motor, widely used for various applications. It operates based on electromagnetic induction.

1. Operation Principle:

- **Slip:** The rotor of an induction motor rotates at a speed slightly less than the synchronous speed of the stator's magnetic field. The difference in speed (known as slip) is necessary for inducing current in the rotor and generating torque.
- **Starting:** Induction motors can start directly on line and do not require external excitation.

2. Key Characteristics:

- **Speed Variation:** The speed varies with load, and it operates at a speed slightly below synchronous speed.
- **Simple and Robust:** Simple construction with fewer parts compared to synchronous motors.
- **Power Factor:** Typically has a lagging power factor, which can be improved with capacitors.

3. Applications:

- Used in a wide range of applications from household appliances to industrial machinery due to their simplicity and robustness.

Combining Concepts: Synchronous Reluctance Motor

If the term **synchronous induction motor** is meant to describe a machine with elements of both synchronous and induction principles, it might refer to the **synchronous reluctance motor**. This is a type of synchronous motor but operates on different principles compared to conventional synchronous motors.

CHAPTER 9

Parallel Operation and Load Sharing

Mrs.R.Nagalakshmi

Parallel Operation and Load Sharing are crucial concepts in electrical power systems, especially when dealing with multiple generators, transformers, or power sources. The goal is to ensure that these devices work together efficiently and effectively, sharing the load and maintaining system stability.

Parallel Operation

Parallel operation refers to the practice of connecting two or more electrical devices, such as generators or transformers, to the same bus or load. This setup allows for increased capacity, redundancy, and reliability in power systems.

Key Considerations for Parallel Operation

1. Voltage Synchronization:

- **Generators:** For generators to operate in parallel, their terminal voltages must be synchronized in magnitude, phase, and frequency. This ensures that they share the load equally and do not cause circulating currents or system instability.
- **Transformers:** When transformers are operated in parallel, their voltages must be the same, and they must be connected to the same phase sequence. This is to avoid circulating currents and ensure effective load sharing.

2. Frequency and Phase Matching:

- **Generators:** Must have their outputs matched in frequency and phase to avoid damaging equipment and to ensure stable operation.
- **Control Systems:** Use synchronizing equipment to match frequency and phase angles before connecting generators to the grid.

3. Load Sharing:

- When multiple generators or transformers are operated in parallel, they should share the load proportionally based on their capacity. This prevents overloading and ensures efficient operation.

Load Sharing

Load sharing involves distributing the electrical load among parallel devices so that each one handles a proportionate share of the total load. This is important for maintaining system reliability, efficiency, and extending equipment life.

Principles of Load Sharing

1. Equal Loading:

- Ideally, each device should share the load in proportion to its rated capacity. For example, if two generators are operating in parallel, each should carry approximately 50% of the total load, assuming they are of equal capacity.

2. Automatic Load Sharing:

- **Generators:** Use load-sharing controllers or governors to automatically adjust the output of each generator based on the load demand. These controllers can be mechanical, hydraulic, or electronic.
- **Transformers:** Load-sharing is managed by ensuring that transformers are properly matched in terms of impedance and capacity. For parallel operation, transformers should ideally have the same voltage ratios and similar impedance characteristics.

3. Manual Load Sharing:

- In some systems, operators may manually adjust the load sharing by controlling the output of each generator or transformer. This is less common with modern systems that use automatic controls.

CHAPTER 10

Regulation of Salient Pole Alternators

Mrs.R.Nagalakshmi

Salient Pole Alternators are a type of synchronous machine used primarily in hydroelectric power plants and other applications where high torque and variable speed operation are common. Their rotor has projecting poles, which give them a distinctive appearance and affect their performance characteristics, particularly in terms of voltage regulation.

Salient Pole Alternators

Salient Pole Alternators are characterized by their rotor design, which features distinct pole projections. This design is suitable for low to medium-speed applications and provides high starting torque.

Key Features of Salient Pole Alternators:

1. **Pole Construction:** The rotor has salient (projecting) poles, which are often used in machines designed for lower speeds (e.g., hydro turbines).
2. **Rotor Design:** The rotor's construction helps in achieving high efficiency and stable operation at varying speeds.
3. **Field Winding:** The field winding is placed on the projecting poles, and the excitation current is supplied through slip rings.
- 4.

Regulation of Salient Pole Alternators

Voltage regulation is crucial for maintaining stable voltage output across varying load conditions. Here's how it is achieved in salient pole alternators:

1. Understanding Voltage Regulation

Voltage Regulation refers to the ability of an alternator to maintain a constant output voltage despite variations in load and power factor. It is defined as the difference between the no-load voltage and the full-load voltage, expressed as a percentage of the full-load voltage.

2. Factors Affecting Regulation

1. **Load Variation:**
 - **Load Increase:** As the load on the alternator increases, the terminal voltage tends to drop due to increased armature reaction and voltage drops in the internal impedance of the machine.
 - **Load Decrease:** When the load decreases, the voltage tends to rise.
2. **Power Factor:**
 - **Lagging Power Factor:** Causes a decrease in terminal voltage due to increased armature reactance.
 - **Leading Power Factor:** Can increase terminal voltage because of the compensating effect on the armature reactance.
3. **Excitation Control:**
 - Adjusting the excitation current (the current supplied to the rotor winding) is crucial for maintaining voltage regulation. Increasing the excitation increases the terminal voltage, while decreasing the excitation lowers it.

3. Methods of Voltage Regulation

1. **Automatic Voltage Regulator (AVR):**
 - **Function:** Automatically adjusts the excitation of the alternator to maintain a constant voltage output. The AVR senses the voltage at the terminals and adjusts the excitation current to correct any deviations.



ELECTRIC CIRCUIT ANALYSIS

EDITED BY

N.MANGALESWARI



978-93-6255-315-7

Electric Circuit Analysis
Copyright © 2023 by Mrs.N.Mangaleswari

All rights reserved. No part of this book may be reproduced or transmitted in any form or by any means without written permission from the author.

ISBN: 978-93-6255-315-7

Publisher: Ponnaiyah Ramajayam Institute of Science and Technology (PRIST)
Date of Publication : 24.1.23

TABLE OF CONTENTS

| | |
|--|------------|
| Introduction | 05 |
| CHAPTER 1 - Basic circuit analysis | 20 |
| Mrs.N.Mangaleswari | |
| CHAPTER 2 - Network Theorems | 38 |
| Mrs.N.Mangaleswari | |
| CHAPTER 3 - Transient response Analysis | 75 |
| Mrs.R.Nagalakshmi | |
| CHAPTER 4 – Resonance and coupled circuits | 145 |
| Mrs.R.Nagalakshmi | |
| CHAPTER 5 – Three phase circuits | 188 |
| Mrs. R. Prasannadevi | |
| CHAPTER 6 – Resistors in series and parallel circuits | 196 |
| Mrs.N.Mangaleswari | |
| CHAPTER 7 – Norton’s Theorem | 207 |
| Mrs.N.Mangaleswari | |
| CHAPTER 8 – Maximum power transfer theorem | 212 |
| Mrs.R.Nagalakshmi | |
| CHAPTER 9 – Frequency response | 223 |
| Mrs.R.Nagalakshmi | |
| CHAPTER 10 – A.C Circuits | 230 |
| Mrs. R. Prasannadevi | |
| REFERENCES | 235 |

CHAPTER 1

Basic circuit analysis

Mrs.N.Mangaleswari

Basic Circuit Analysis

Basic circuit analysis involves understanding and solving electrical circuits to determine voltages, currents, and resistances. It provides the foundation for designing and analyzing more complex electronic systems. Here, we'll cover fundamental principles and methods used in circuit analysis.

1. Ohm's Law

Definition: Ohm's Law states that the voltage across a conductor is directly proportional to the current flowing through it and inversely proportional to its resistance.

Formula: $V=I \cdot R$

2. Kirchhoff's Laws

2.1 Kirchhoff's Voltage Law (KVL)

Definition: The sum of all voltages around a closed loop in a circuit is zero. This is based on the principle of energy conservation.

2.2 Kirchhoff's Current Law (KCL)

Definition: The sum of currents entering a junction equals the sum of currents leaving the junction. This is based on the principle of charge conservation.

3. Series and Parallel Circuits

3.1 Series Circuits

Definition: In a series circuit, components are connected end-to-end, and the same current flows through each component.

3.2 Parallel Circuits

Definition: In a parallel circuit, components are connected across the same voltage source, and the voltage across each component is the same.

4. Thevenin's and Norton's Theorems

4.1 Thevenin's Theorem

Definition: Any linear circuit can be replaced by an equivalent circuit with a single voltage source in series with a resistor.

4.2 Norton's Theorem

Definition: Any linear circuit can be replaced by an equivalent circuit with a single current in parallel with a resistor.

5. Mesh and Nodal Analysis

5.1 Mesh Analysis

Definition: A method for analyzing planar circuits by writing KVL for each mesh (loop) in the circuit.

Steps:

1. Identify all meshes in the circuit.

CHAPTER 2

Network Theorems

Mrs.N.Mangaleswari

Network Theorems

Network theorems are essential tools for analyzing electrical circuits and systems. They simplify the process of solving complex networks by providing methods to reduce or transform circuits into more manageable forms. Here are the key network theorems commonly used in circuit analysis:

1. Ohm's Law

Definition: Ohm's Law states that the voltage across a conductor is directly proportional to the current flowing through it and inversely proportional to its resistance.

Formula: $V=I \cdot R$

2. Kirchhoff's Laws

2.1 Kirchhoff's Voltage Law (KVL)

Definition: The sum of all voltages around a closed loop in a circuit is zero. This is based on the principle of energy conservation.

2.2 Kirchhoff's Current Law (KCL)

Definition: The sum of currents entering a junction equals the sum of currents leaving the junction. This is based on the principle of charge conservation.

3. Thevenin's and Norton's Theorems

3.1 Thevenin's Theorem

Definition: Any linear circuit can be replaced by an equivalent circuit with a single voltage source in series with a resistor.

4.2 Norton's Theorem

Definition: Any linear circuit can be replaced by an equivalent circuit with a single current in parallel with a resistor.

4. Superposition Theorem

Definition: In a linear circuit with multiple independent sources, the total response (voltage or current) is the sum of the responses due to each independent source acting alone.

Steps:

1. **Deactivate All Sources Except One:** Replace all independent voltage sources with short circuits and current sources with open circuits.
2. **Analyze the Circuit:** Find the response due to the active source.
3. **Repeat:** Repeat the process for each source.
4. **Sum Responses:** Add the individual responses to obtain the total response.

5. Maximum Power Transfer Theorem

Definition: The maximum power is transferred to a load when the load resistance R_L equals the Thevenin resistance R_{th} of the network supplying the power.

Formula: $R_L=R_{th}$

Applications:

- Designing circuits to ensure efficient power transfer to the load.

CHAPTER 3

Transient response Analysis

Mrs.R.Nagalakshmi

Transient Response Analysis

Transient response analysis is a critical aspect of understanding how electrical circuits behave when subjected to sudden changes, such as the application or removal of a voltage or current source. This analysis helps engineers design circuits that respond predictably to these changes and ensures stability and performance in practical applications.

1. Introduction to Transients

Definition: A transient response is the temporary behavior of a circuit as it transitions from one steady-state condition to another in response to a sudden change in inputs or initial conditions.

Key Concepts:

- **Steady-State:** The long-term behavior of the circuit after transients have decayed.
- **Transient:** The short-term response that occurs before the circuit reaches a steady-state.

2. Types of Transient Response

2.1 First-Order Transient Response

Definition: A first-order circuit contains only one energy storage element (capacitor or inductor) and exhibits a transient response characterized by a single exponential term.

Second-Order Transient Response

Definition: A second-order circuit contains two energy storage elements (both capacitors and inductors) and exhibits a transient response characterized by two exponential terms or a combination of exponential and sinusoidal terms.

Analysis Techniques

Time Domain Analysis

Definition: Analyzing the circuit's response in the time domain by solving differential equations that describe the circuit's behavior.

Steps:

1. Write the differential equations based on Kirchhoff's laws.
2. Solve the differential equations to find the time-domain response.

4.2 Frequency Domain Analysis

Definition: Analyzing the circuit's response by transforming the time-domain equations into the frequency domain using Laplace Transforms.

Steps:

1. Convert the circuit elements into their s-domain equivalents
2. Solve the algebraic equations in the s-domain.
3. Use the inverse Laplace Transform to convert back to the time domain.

CHAPTER 4

Resonance and coupled circuits

Mrs.N.Mangaleswari

Resonance and Coupled Circuits

Resonance and coupled circuits are fundamental concepts in electrical engineering and electronics, particularly in the context of AC analysis and circuit design. These concepts are crucial for understanding the behavior of circuits with reactive components and for designing systems like filters and oscillators.

1. Resonance in Circuits

Definition: Resonance occurs in a circuit when the reactive effects of inductors and capacitors cancel each other out, resulting in maximum or minimum impedance at a particular frequency. At resonance, the circuit can oscillate with minimal external energy input.

Types of Resonance:

1.1 Series Resonance

Definition: In a series resonant circuit, an inductor (L) and capacitor (C) are connected in series with a resistor (R), and the circuit resonates at a specific frequency.

Parallel Resonance

Definition: In a parallel resonant circuit, an inductor and capacitor are connected in parallel with a resistor. The circuit resonates when the impedance of the parallel combination is maximized.

Coupled Circuits

Definition: Coupled circuits involve multiple inductors or transformers that are linked through mutual inductance. These circuits are analyzed to understand the interaction between the components and their combined effects.

2.1 Mutual Inductance

Definition: Mutual inductance (M) is a measure of the influence of one inductor on another due to their magnetic fields. It arises in coupled inductors and transformers.

Coupled Inductors

Definition: When two inductors are placed close to each other, their magnetic fields interact. This interaction can be described by mutual inductance, which affects the overall impedance and behavior of the circuit.

Resonance and Coupled Circuits in Practice

3.1 Applications of Resonance

- **Filters:** Resonant circuits are used in filter designs (low-pass, high-pass, band-pass, and band-stop filters) to allow or block specific frequencies.
- **Oscillators:** Resonance is fundamental in oscillator circuits, which generate periodic waveforms.
- **Tuning Circuits:** Used in radios and TVs to select specific frequencies from a broad spectrum.

3.2 Applications of Coupled Circuits

- **Transformers:** Used to step up or step down voltages in power supplies and signal processing.
- **Inductive Coupling:** Applied in wireless power transfer systems and communication systems.
- **Filter Design:** Coupled inductors are used in designing filters with specific frequency responses.

CHAPTER 5

Three phase circuits

Mr.D.Hariharan

Three-Phase Circuits

Three-phase circuits are a type of AC (Alternating Current) system widely used in power generation, transmission, and distribution due to their efficiency and balance. They are essential for powering large industrial motors, generating electricity, and delivering power over long distances.

1. Basic Concepts of Three-Phase Systems

1.1 Definition

A three-phase system consists of three AC voltages or currents that are equal in magnitude but are phase-shifted by 120 degrees from each other. This phase difference creates a balanced system with constant power delivery.

1.2 Phases

- **Phase:** Refers to the individual AC waveform in the system. In a three-phase system, there are three phases.
- **Phase Angle:** The angle by which each phase is shifted relative to the others. In a three-phase system, the phase angle between each pair of phases is 120 degrees.

1.3 Voltage and Current Types

- **Line Voltage (V_L):** The voltage measured between any two of the three-phase lines.
- **Phase Voltage (V_P):** The voltage measured between any one phase and the neutral point.
- **Line Current (I_L):** The current flowing through each of the three-phase lines.
- **Phase Current (I_P):** The current flowing through each load in a we-connected system.

Balanced and Unbalanced Loads

3.1 Balanced Load

Definition: A balanced load occurs when the impedances in all three phases are equal, and the system is symmetrical. This results in equal current and voltage magnitudes in each phase.

Analysis:

- **Balanced Load Currents:** Equal currents in all three phases.
- **Neutral Current:** Zero in a perfectly balanced system.

Unbalanced Load

Definition: An unbalanced load occurs when the impedances in the three phases are unequal, leading to unequal currents and voltages.

Analysis:

- **Phase Currents:** Unequal due to different impedances.
- **Neutral Current:** Non-zero, calculated by summing the phase currents.
- **Power Factor**
- **Definition:** The power factor is the cosine of the phase angle (ϕ) between the voltage and current.
- **Formula:** Power Factor = $\cos(\phi)$

CHAPTER 6

Resistors in series and parallel circuits

Mrs.N.Mangaleswari

Resistors in Series and Parallel Circuits are fundamental concepts in electrical and electronic circuits. Understanding how resistors combine in series and parallel configurations is crucial for analyzing and designing electrical circuits.

Resistors in Series

Series Configuration: When resistors are connected end-to-end, one after the other, they are said to be in series. The same current flows through each resistor in a series circuit.

Voltage Division: If the total voltage V_{total} across the series is 30V, the voltage drop across each resistor can be calculated using Ohm's law:

Resistors in Parallel

Parallel Configuration: When resistors are connected to the same pair of nodes, they are said to be in parallel. Each resistor experiences the same voltage across it, but the current divides among them.

Characteristics:

1. **Total Resistance:** The total resistance R_{total} in a parallel circuit is found using the reciprocal
Voltage: The voltage across each resistor in a parallel circuit is the same and equal to the total voltage across the parallel network.
Current Division: The total current I_{total} is the sum of the currents through each resistor:

Summary

- **Resistors in Series:**
 - **Total Resistance:** Sum of individual resistances.
 - **Current:** Same through all resistors.
 - **Voltage:** Divided among resistors according to their resistance values.
- **Resistors in Parallel:**
 - **Total Resistance:** Reciprocal of the sum of reciprocals of individual resistances.
 - **Voltage:** Same across all resistors.
 - **Current:** Divided among resistors according to their resistance values.

Basic Characteristics of Parallel Resistors

1. **Voltage Across Resistors:**
 - In a parallel circuit, the voltage across each resistor is the same. This is a key characteristic of parallel connections.
2. **Current Through Each Resistor:**
 - The current through each resistor is different and depends on its resistance, following Ohm's law. The total current entering the parallel network is the sum of the currents through each resistor.
3. **Total Resistance:**
 - The total or equivalent resistance R_{eq} of resistors in parallel is always less than the smallest individual resistor's resistance. This is because the total current is divided among the parallel branches, reducing the overall opposition to current flow.

CHAPTER 7

Norton's Theorem

Mrs.N.Mangaleswari

Norton's Theorem is a fundamental principle in electrical engineering used for simplifying complex linear electrical circuits. It provides a method to replace any linear circuit with a simpler equivalent circuit consisting of a current source in parallel with a resistor. This theorem is particularly useful for analyzing circuits with multiple sources and resistors.

Norton's Theorem Overview

Statement: Any linear electrical network with multiple voltage sources, current sources, and resistors can be simplified to an equivalent circuit that consists of a single current source I_{NI} in parallel with a single resistor R_{NR} . This equivalent circuit will have the same current and voltage characteristics at the terminals of interest as the original circuit.

Steps to Apply Norton's Theorem

1. **Find the Norton Current (I_{NI}):**

- **Norton Current (I_{NI}):** This is the current flowing through the terminals of the circuit when they are short-circuited.
- To find I_{NI} :
 - Short-circuit the output terminals where you want to find the equivalent.
 - Calculate the current flowing through the short circuit.

2. **Find the Norton Resistance (R_{NR}):**

- **Norton Resistance (R_{NR}):** This is the equivalent resistance of the network as seen from the terminals of interest when all independent voltage sources are replaced by short circuits and all independent current sources are replaced by open circuits.
- To find R_{NR} :
 - Turn off all independent sources in the circuit.
 - Calculate the resistance seen from the terminals.

3. **Construct the Norton Equivalent Circuit:**

- Replace the original circuit with a current source I_{NI} in parallel with a resistor R_{NR} .
- This equivalent circuit will be used to analyze the behavior of the circuit at the terminals of interest.

Norton's Theorem vs. Thevenin's Theorem

Norton's Theorem and Thevenin's Theorem are closely related. They both provide methods for simplifying complex linear circuits but use different approaches:

- **Norton's Theorem:** Represents the circuit with a current source I_{NI} in parallel with a resistor R_{NR} .
- **Thevenin's Theorem:** Represents the circuit with a voltage source V_{th} in series with a resistor R_{th} .

CHAPTER 8

Maximum power transfer theorem

Mrs.R.Nagalakshmi

The Maximum Power Transfer Theorem is a fundamental principle in electrical engineering that specifies the conditions under which a load receives the maximum possible power from a source. This theorem is widely used in circuit design and analysis to ensure efficient power delivery to loads.

Statement of the Maximum Power Transfer Theorem

The Maximum Power Transfer Theorem states that in order to maximize the power delivered to a load, the resistance of the load (R_L) must be equal to the resistance of the source network as seen from the load terminals (R_{th}), which is also known as the Thevenin resistance of the source network.

Mathematical Formulation

1. Maximum Power Delivered to Load:

- **Load Resistance (R_L):** The resistance of the load connected to the circuit.
- **Thevenin Resistance (R_{th}):** The equivalent resistance of the source network when viewed from the load terminals.

Proof of the Maximum Power Transfer Theorem

To derive the condition for maximum power transfer, consider a circuit with a voltage source V_{th} in series with a Thevenin resistance R_{th} and a load resistance R_L :

Applications and Considerations

1. Impedance Matching:

- In practical applications, such as in audio systems or communication networks, impedance matching is crucial to ensure maximum power transfer from the source to the load.

2. Efficiency:

- While the theorem ensures maximum power transfer, it does not necessarily imply maximum efficiency. In many cases, maximizing efficiency may require a different load impedance.

3. Load Variation:

- In real-world scenarios, the load may not always be adjustable to match R_{th} , so alternative methods such as using matching networks or transformers may be employed.

The Maximum Power Transfer Theorem provides a method for ensuring that a load receives the maximum power possible from a source by matching the load resistance to the source's Thevenin resistance. This principle is widely applied in circuit design and practical electronics to optimize power delivery and system performance.

CHAPTER 9

Frequency response

Mrs.R.Nagalakshmi

Frequency response is a key concept in signal processing and systems analysis that describes how a system reacts to different frequencies of input signals. It provides insight into the behavior of systems like filters, amplifiers, and communication channels, showing how the amplitude and phase of the output signal vary with frequency.

Understanding Frequency Response

The frequency response of a system can be analyzed by applying sinusoidal inputs at various frequencies and observing the system's output. It is often represented as a graph or a set of equations that describe how the system amplifies or attenuates signals of different frequencies.

Key Concepts

Magnitude Response:

- **Definition:** Shows how the amplitude (or magnitude) of the output signal changes with frequency.
- **Representation:** Often plotted as a Bode magnitude plot (in decibels) versus frequency.

Phase Response:

- **Definition:** Indicates how the phase of the output signal is shifted relative to the input signal at different frequencies.
- **Representation:** Often plotted as a Bode phase plot (in degrees) versus frequency.

Transfer Function:

- **Definition:** The transfer function $H(f)$ of a linear time-invariant (LTI) system is a complex function that describes the system's output-to-input ratio as a function of frequency.

Bode Plots:

- **Magnitude Plot:** Displays the magnitude of $H(f)$ in decibels (dB) versus frequency (usually on a logarithmic scale).
- **Phase Plot:** Shows the phase shift in degrees versus frequency (often on a logarithmic scale).

Logarithmic Scales:

- **Decibels (dB):** Magnitude is often expressed in decibels

Frequency Response of Common Systems

1. Low-Pass Filter:

- **Purpose:** Allows low frequencies to pass while attenuating higher frequencies.
- **Magnitude Response:** Flat at low frequencies, decreases after a cutoff frequency.
- **Phase Response:** Phase lag increases with frequency.

2. High-Pass Filter:

- **Purpose:** Allows high frequencies to pass while attenuating lower frequencies.
- **Magnitude Response:** Flat at high frequencies, decreases at low frequencies.
- **Phase Response:** Phase lag decreases with frequency.

3. Band-Pass Filter:

- **Purpose:** Allows frequencies within a certain range to pass while attenuating frequencies outside this range.
- **Magnitude Response:** Peaks within the passband and attenuates outside it.
- **Phase Response:** Phase shift varies across the passband.

CHAPTER 10

A.C Circuits

Mrs. R. Prasannadevi

Alternating Current (AC) Circuits are a fundamental aspect of electrical engineering and power systems. AC circuits use alternating current, which periodically reverses direction, unlike direct current (DC) circuits where the current flows in a single direction. AC circuits are used in almost all power distribution systems and many electronic devices.

Key Concepts of AC Circuits

1. Alternating Current (AC):

- **Definition:** AC is an electric current that reverses direction periodically. It is characterized by its sinusoidal waveform, though other waveforms such as square and triangular waves are also used.
- **Frequency:** The number of cycles the current completes in one second, measured in Hertz (Hz). For example, in most countries, the standard frequency is 50 Hz or 60 Hz.

2. Sinusoidal Waveform:

- **Amplitude (Peak Value):** The maximum value of the voltage or current.
- **Peak-to-Peak Value:** The total variation from the maximum positive to the maximum negative value.
- **RMS (Root Mean Square) Value:** Represents the effective value of AC and is used for calculating power. For a sinusoidal waveform, **Phase Angle:** The angle by which the waveform is shifted from a reference waveform, often used to describe the phase difference between voltage and current.

3. Impedance (Z):

- **Definition:** The total opposition a circuit presents to the flow of AC, combining resistance (R), inductive reactance (X_L), and capacitive reactance (X_C).
- **Units:** Ohms (Ω)

4. Reactance:

- **Inductive Reactance (X_L):** Opposition to AC due to inductors, **Capacitive Reactance (X_C):** Opposition to AC due to capacitors.

5. Phasors:

- **Definition:** Phasors are complex numbers used to represent AC voltages and currents. They simplify the analysis of AC circuits by converting differential equations into algebraic equations.
- **Representation:** A phasor is represented by a magnitude and a phase angle, which can be used to analyze the relationship between voltage and current in the circuit.

Types of AC Circuits

1. Resistive AC Circuit:

- **Components:** Contains only resistors.
- **Behavior:** The current and voltage are in phase, meaning the phase angle ϕ



ENGINEERING MECHANICS

EDITED BY

J.SANTHIYAA JENIFER



978-93-6255-326-3

Engineering Mechanics
Copyright © 2023 by J.Santhiyaa Jenifer

All rights reserved. No part of this book may be reproduced or transmitted in any form or by any means without written permission from the author.

ISBN: 978-93-6255-326-3

Publisher: Ponnaiyah Ramajayam Institute of Science and Technology (PRIST)

TABLE OF CONTENTS

| | | |
|--|---|-----|
| INTRODUCTION | - | 05 |
| CHAPTER 1 - Statics of Particles | - | 15 |
| Mrs.R.Devi | | |
| CHAPTER 2—Equilibrium of Rigid Bodies | - | 28 |
| Mr.D.Jeyakumar | | |
| CHAPTER 3 - Distributed Forces | - | 41 |
| D.AmalColins | | |
| CHAPTER 4—Friction | - | 62 |
| Mrs.K.Shanthi | | |
| CHAPTER 5 -Dynamics of Particles | - | 78 |
| Mrs.M.Karpagam | | |
| CHAPTER 6 -Strength of materials | - | 92 |
| Mrs.R.Devi | | |
| CHAPTER 7 -Applied mechanics | - | 120 |
| Mr.D.Jeyakumar | | |
| CHAPTER 8 -Solid mechanics | - | 135 |
| Mrs.K.Shanthi | | |
| CHAPTER 9 -Method of moments | - | 148 |
| Mrs.M.Karpagam | | |
| CHAPTER 10-Unit of measurement | - | 160 |
| Mr.D.AmalColins | | |
| REFERENCES | - | 180 |

CHAPTER 1

Statics of Particles

Mrs.R.Devi

Statics of particles is a fundamental concept in engineering and physics, focusing on the study of forces and their effects on particles (or bodies) that are in equilibrium. Here's a concise overview:

1. Equilibrium:

- For a particle to be in equilibrium, the net force acting on it must be zero. This is described by the equation: $\sum \vec{F} = 0$
- In two dimensions, this means that both the x-components and y-components of the forces must individually sum to zero: $\sum F_x = 0$ $\sum F_y = 0$
- In three dimensions, this extends to the z-component as well: $\sum F_z = 0$

2. Forces:

- **Contact Forces:** These include normal forces, frictional forces, and tension.
- **Non-Contact Forces:** These include gravitational forces and electrostatic forces.

3. Free-Body Diagrams (FBD):

- A crucial tool in statics, where you draw a simplified diagram of a particle or body showing all external forces acting on it. This helps in setting up equations based on equilibrium conditions.

4. Equilibrium Conditions:

- **Static Equilibrium:** The particle is at rest and not accelerating. The sum of all forces is zero.
- **Dynamic Equilibrium:** Even if a particle is moving with constant velocity, if no net force acts on it, it's considered in equilibrium.

5. Examples of Applications:

- Determining the forces in static structures like bridges and buildings.
- Analyzing the forces on components in machinery when they are not accelerating

CHAPTER 2

Equilibrium of Rigid Bodies

Mr.D.Jeyakumar

A rigid body in mechanics is an idealization of a solid body in which deformation is negligible and all particles of the body maintain a constant distance relative to each other. This simplification allows for a more straightforward analysis of forces and motions, especially in the context of equilibrium and dynamics. Here's a detailed look at the fundamental aspects of rigid bodies:

Key Concepts:

1. Definition and Properties:

- **Rigid Body:** A solid object that does not deform or change shape under the action of forces. The distances between any two points within the body remain constant.
- **Center of Mass (CM):** The point where the mass of the body can be considered to be concentrated for the purposes of analyzing translational motion. For a rigid body, this point is critical for simplifying the analysis of forces and torques.

2. Types of Motion:

- **Translational Motion:** The entire body moves in a straight line or along a curved path. In this motion, all points of the rigid body move parallel to each other.
- **Rotational Motion:** The body rotates about a fixed axis or point. Different points in the body move in circular paths around the axis.
- **General Motion:** A combination of translational and rotational motion.

3. Equilibrium of Rigid Bodies:

For a rigid body to be in equilibrium, it must satisfy both translational and rotational equilibrium conditions:

Translational Equilibrium:

- The sum of all external forces acting on the body must be zero: $\sum \vec{F} = 0$
- $\sum F = 0$ This ensures that there is no net force causing linear acceleration.

Rotational Equilibrium:

- The sum of all moments (torques) about any point must be zero: $\sum \vec{M} = 0$
- $\sum M = 0$ This ensures that there is no net torque causing angular acceleration.

4. Free-Body Diagrams (FBD):

A Free-Body Diagram is a simplified representation of a rigid body isolated from its surroundings, showing all external forces and moments acting on it. This helps in setting up and solving equilibrium equations.

5. Moments (Torques):

CHAPTER 3

Distributed Forces

Mr.D.AmalColins

Distributed forces, also known as distributed loads, are forces that are spread over an area, length, or volume, rather than being concentrated at a single point. They are commonly encountered in structural analysis and mechanics, particularly when dealing with beams, surfaces, and bodies subjected to various types of loading conditions.

Types of Distributed Forces:

1. Uniformly Distributed Load (UDL):

- A load that is evenly distributed along the length of a beam or across a surface.
- For a beam, it is often expressed as a force per unit length, w (e.g., N/m).
- For a surface, it is expressed as a force per unit area, q (e.g., N/m²).

2. Non-Uniformly Distributed Load:

- A load that varies along the length or area. It can be linear, parabolic, or follow other functional forms.
- For a beam, this might be represented as $w(x)$, where x is the position along the length.
- For a surface, this might be represented as $q(x,y)$, where x and y are coordinates on the surface.

Calculating Reactions and Effects of Distributed Loads:

1. Finding the Resultant Force:

- The resultant force of a distributed load is equivalent to the total force exerted by the distributed load and can be found by integrating the distribution function over the area or length.
- For a uniformly distributed load w over a length L : $F_{\text{resultant}}=w \cdot L$
- For a uniformly distributed load q over an area A : $F_{\text{resultant}}=q \cdot A$

2. Finding the Location of the Resultant Force:

- The resultant force of a distributed load acts at the centroid of the distribution. For a uniformly distributed load, this point is at the midpoint of the length or area.
- For a uniform distributed load w on a beam from $x=0$ to $x=L$, the resultant force acts at $L/2$ from either end.
- For non-uniformly distributed loads, the location of the resultant force is found by calculating the centroid of the load distribution.

Applications:

- **Structural Engineering:** Analysis of beams, slabs, and other structural elements subject to distributed loads.
- **Mechanical Engineering:** Design of components that experience distributed forces, such as rotating machinery.
- **Civil Engineering:** Analysis of loads on roads, pavements, and other civil structures. By accurately analyzing and calculating distributed forces, engineers can ensure that structures are designed to handle the loads they will encounter in service, maintaining safety and stability.

CHAPTER 4

Friction

Mrs.K.Shanthi

Friction is the force that opposes the relative motion or tendency of motion between two surfaces in contact. It plays a crucial role in a wide range of applications, from preventing slipping to enabling traction and stability in various mechanical systems.

Types of Friction:

1. Static Friction:

- **Definition:** The frictional force that prevents two surfaces from sliding past each other. It must be overcome to initiate motion.
- **Formula:** $F_s \leq \mu_s \cdot N$
- **Maximum Static Friction:** $F_{s,max} = \mu_s \cdot N$

Kinetic (Dynamic) Friction:

- **Definition:** The frictional force that opposes the relative motion of two surfaces already in motion.
- **Formula:** $F_k = \mu_k \cdot N$

Rolling Friction:

- **Definition:** The resistance to rolling motion between a rolling object and the surface it rolls on.
- **Formula:** $F_r = \mu_r \cdot N$

Fluid Friction (Drag):

- **Definition:** The resistance encountered by an object moving through a fluid (liquid or gas).
- **Formula:** $F_d = 1/2 \cdot \rho \cdot v^2 \cdot A \cdot C_d$

Factors Affecting Friction:

1. **Nature of the Surfaces:**
 - Rougher surfaces generally have higher coefficients of friction compared to smoother surfaces.
2. **Normal Force:**
 - Frictional force is directly proportional to the normal force acting between the surfaces.
3. **Presence of Lubricants:**
 - Lubricants can reduce friction by creating a thin layer between surfaces.
4. **Material Properties:**
 - The coefficients of friction vary with different materials and their interactions.

CHAPTER 5

Dynamics of Particles

Mrs.M.Karpagam

The dynamics of particles is a branch of classical mechanics that deals with the study of forces and motions of individual particles. It is concerned with understanding how forces influence the motion of particles and how to describe and predict their behavior using principles of mechanics.

Particle Definition

In physics, a particle is considered a point mass an idealization where the size and shape of the object are ignored, and only its mass and motion are taken into account. This simplification makes it easier to apply Newton's laws to predict its behavior.

Newton's Laws of Motion

The foundation of particle dynamics lies in **Newton's three laws of motion**:

- **First Law (Law of Inertia):** A particle will remain at rest or continue to move in a straight line with constant velocity unless acted upon by a net external force.
- **Second Law (Law of Acceleration):** The acceleration of a particle is proportional to the net force applied to it and inversely proportional to its mass, described by $F=ma$ where F is the force, m is the mass, and a is the acceleration.
- **Third Law (Action and Reaction):** For every action, there is an equal and opposite reaction.

Kinematics vs Dynamics

- **Kinematics:** Describes how particles move without regard to the forces causing the motion. It focuses on position, velocity, and acceleration as functions of time.
- **Dynamics:** In contrast, dynamics studies the relationship between motion and the forces that produce it.

Types of Forces Influencing Particle Dynamics

- **Gravitational Force:** The force of attraction between particles due to their masses.
- **Frictional Force:** The force that resists the motion of a particle when it moves relative to another object.
- **Tension, Normal, and Applied Forces:** These forces come into play depending on the particle's interaction with other objects (e.g., pulling by a rope or a normal force exerted by a surface).
- **Electromagnetic Forces:** Act on charged particles in an electromagnetic field.
- **Centripetal Force:** Required for circular motion, directed towards the center of the path.

Applications

The dynamics of particles have a broad range of applications:

- **Orbital mechanics:** Studying the motion of planets, satellites, and other celestial bodies.
- **Particle physics:** Describing the behavior of subatomic particles.
- **Classical mechanics:** Engineering applications, such as the design of mechanical systems like engines and vehicles.

CHAPTER 6

Strength of materials

Mrs.R.Devi

Strength of materials is a fundamental concept in engineering that deals with the ability of materials to withstand various types of forces and loads without failing. It encompasses the study of how materials deform and ultimately fail under different types of stress, which is critical for designing and analyzing structural components and systems.

Key Concepts in Strength of Materials

1. Stress and Strain

- **Stress:** The internal force per unit area within materials. It is calculated as:

$$\text{Stress}(\sigma) = \text{Force} / \text{Area}$$

Types of stress include:

- **Normal Stress:** Stress acting perpendicular to the cross-section (tensile or compressive).
- **Shear Stress:** Stress acting parallel to the cross-section.
- **Strain:** The measure of deformation representing the displacement between particles in a material. It is calculated as:

$$\text{Strain}(\epsilon) = \text{Change in Length} / \text{Original Length}$$

Types of strain include:

- **Normal Strain:** Change in length divided by the original length (tensile or compressive strain).
- **Shear Strain:** Change in angle between two lines divided by the original angle.

2. Elasticity and Plasticity

- **Elasticity:** The ability of a material to return to its original shape after the stress is removed. This behavior is described by Hooke's Law:
- **Plasticity:** The ability of a material to undergo permanent deformation without breaking. When the stress exceeds the material's yield strength, it deforms plastically.

3. Material Properties

- **Young's Modulus (E):** A measure of the stiffness of a material, representing the ratio of tensile stress to tensile strain in the elastic region.
- **Shear Modulus (G):** Describes the material's response to shear stress, representing the ratio of shear stress to shear strain.
- **Bulk Modulus (K):** Measures a material's resistance to uniform compression, representing the ratio of volumetric stress to volumetric strain.
- **Yield Strength:** The stress at which a material begins to deform plastically.
- **Ultimate Tensile Strength (UTS):** The maximum stress a material can withstand while being stretched or pulled before breaking.

CHAPTER 7

Applied mechanics

Mr.D.Jeyakumar

Applied mechanics is a branch of engineering that focuses on the practical application of mechanics principles to solve real-world problems involving forces, motion, and energy. It combines concepts from physics and mathematics to analyze and design systems and structures in various fields of engineering.

Key Areas of Applied Mechanics

1. Statics

Statics deals with the analysis of forces and moments on objects that are in a state of rest or moving at a constant velocity. The primary goal is to ensure that the forces and moments are balanced, resulting in equilibrium.

Equilibrium Conditions: For a body to be in static equilibrium, the sum of all forces and moments acting on it must be zero: $\sum F=0$ $\sum M=0$

- **Free-Body Diagrams:** Diagrams used to represent all the forces and moments acting on a body to analyze equilibrium conditions.
- **Support Reactions:** Calculating reactions at supports and connections in structures like beams and trusses.

2. Dynamics

Dynamics focuses on the study of forces and their effects on objects in motion. It includes the analysis of acceleration, velocity, and forces causing motion.

- **Newton's Laws of Motion:** Fundamental principles governing the relationship between forces and motion:
 - **First Law (Inertia):** An object will remain at rest or in uniform motion unless acted upon by an external force.
 - **Second Law ($F=ma$):** The acceleration of an object is directly proportional to the net force acting on it and inversely proportional to its mass.
 - **Third Law (Action and Reaction):** For every action, there is an equal and opposite reaction.
- **Kinematics:** Study of motion without considering forces, including displacement, velocity, and acceleration.
- **Kinetics:** Analysis of forces and moments causing motion, including work, energy, and power.

3. Mechanics of Materials

Mechanics of materials, also known as strength of materials, deals with the behavior of materials under various types of loading conditions. It includes:

- **Stress and Strain Analysis:** Evaluating how materials deform under applied forces, including tensile, compressive, and shear stresses.
- **Elasticity and Plasticity:** Studying material behavior within the elastic range and after yielding.
- **Failure Theories:** Predicting material failure based on stress and strain criteria, such as the Von Mises criterion and maximum shear stress theory.
- **Deflection and Deformation:** Calculating how structures bend or deform under loads.

CHAPTER 8

Applied mechanics

Mrs.K.Shanthi

Solid mechanics is a branch of applied mechanics that focuses on the behavior of solid materials under various types of loading and boundary conditions. It deals with how materials deform, fail, and respond to forces, moments, and other external factors. The goal is to understand and predict how materials and structures will behave under different conditions to ensure safety, reliability, and performance in engineering applications.

Key Concepts in Solid Mechanics

1. Stress and Strain

- **Stress:** The internal force per unit area within a material. It is a measure of the intensity of internal forces.
 - **Normal Stress:** Acts perpendicular to a surface, including tensile stress (stretching) and compressive stress (squeezing).
 - **Shear Stress:** Acts parallel to a surface, causing one part of a material to slide relative to another.
- **Strain:** The measure of deformation representing the displacement between particles in a material.
 - **Normal Strain:** The change in length divided by the original length, representing tensile or compressive deformation.
 - **Shear Strain:** The change in angle between two lines divided by the original angle, representing shear deformation.

2. Elasticity and Plasticity

- **Elasticity:** The property of a material to return to its original shape after the removal of applied stress. Elastic behavior is described by Hooke's Law:
- **Plasticity:** The ability of a material to undergo permanent deformation without breaking. Plastic behavior occurs when the stress exceeds the material's yield strength.

3. Material Properties

- **Young's Modulus (E):** Measures the stiffness of a material, representing the ratio of tensile stress to tensile strain in the elastic range.
- **Shear Modulus (G):** Represents the material's response to shear stress, defined as the ratio of shear stress to shear strain.
- **Bulk Modulus (K):** Measures the material's resistance to uniform compression, defined as the ratio of volumetric stress to volumetric strain.
- **Yield Strength:** The stress at which a material begins to deform plastically.
- **Ultimate Tensile Strength (UTS):** The maximum stress a material can withstand while being stretched or pulled before breaking.
- **Fracture Toughness:** The ability of a material to resist crack propagation and failure.

4. Stress-Strain Relationships

- **Uniaxial Tension/Compression:** Analyzing stress and strain in a material subjected to a single axis of force, useful for understanding fundamental material behavior.

CHAPTER 9

Method of moments

Mrs.M.Karpagam

The **Method of Moments (MoM)** is a mathematical technique used in various fields, including statistics, structural analysis, electromagnetics, and solid mechanics, to solve equations and model problems by expressing unknown parameters as moments. In engineering, it is particularly useful in analyzing structural systems, especially when determining forces and moments in statically indeterminate structures. Here's an explanation of its applications in different fields:

1. Method of Moments in Structural Analysis

In structural mechanics, the Method of Moments is often used to analyze **indeterminate beams and frames** where the number of reactions or internal forces exceeds the number of equilibrium equations available.

Key Concepts:

- **Moment Equilibrium:** The method involves writing moment equilibrium equations at specific points (nodes or supports) to relate unknown reactions and forces.

Application in Beams:

- When applied to beams, the method helps in determining bending moments and shear forces, especially in cases where the structure is statically indeterminate.

Steps in Structural Analysis:

1. **Assign Unknowns:** Identify unknown moments at supports or joints.
2. **Write Equilibrium Equations:** Use moment equilibrium and force equilibrium conditions for the entire structure or for segments of the structure.
3. **Apply Compatibility Conditions:** Ensure continuity in deflections and rotations across supports and joints by using the relationship between moments and deflections.
4. **Solve System of Equations:** Solve the resulting system of linear equations to determine the unknown moments and reactions.

For example, in a continuous beam, the Method of Moments is used to set up equations based on moment distribution at different points, considering factors like bending stiffness and span lengths.

2. Method of Moments in Electromagnetics

In electromagnetics, the Method of Moments (MoM) is a powerful tool for solving integral equations related to **antenna design, scattering problems**, and the behavior of electromagnetic fields.

Key Concepts:

- **Integral Equations:** MoM is used to convert integral equations (typically derived from Maxwell's equations) into a system of linear algebraic equations that can be solved numerically.

Steps:

1. **Discretization:** The continuous electromagnetic problem is divided into smaller elements or segments.

CHAPTER 10

Unit of measurement

Mr.D.Amal Colins

A **unit of measurement** is a standard quantity used to express a physical quantity. Units of measurement are essential for ensuring consistency and clarity in communication of measurements across various fields like science, engineering, commerce, and daily life.

Types of Units of Measurement

1. **Base Units:** These are the fundamental units from which other units are derived.
2. **Derived Units:** Units that are combinations of base units, used to measure more complex quantities.
3. **Supplementary Units:** Certain units that do not fit neatly into base or derived categories but are still widely used.

Standard Systems of Measurement

There are two main systems of measurement used worldwide:

1. International System of Units (SI Units)

The **SI system** is the modern form of the metric system and is the most widely used globally. It consists of seven base units and a number of derived units.

2. Imperial System

The **Imperial system** is used primarily in the United States and a few other countries, consisting of units like inches, feet, pounds, and gallons.

SI Base Units

The SI system includes seven **base units**, each corresponding to a fundamental physical quantity.

| Physical Quantity | Unit Name | Symbol |
|---------------------|-----------|--------|
| Length | Meter | m |
| Mass | Kilogram | kg |
| Time | Second | s |
| Electric Current | Ampere | A |
| Temperature | Kelvin | K |
| Amount of Substance | Mole | mol |
| Luminous Intensity | Candela | cd |

SI Derived Units

Derived units are combinations of base units. Some commonly used derived units include:

| Physical Quantity | Unit Name | Symbol | Base Unit Combination |
|-------------------|-----------|--------|---|
| Force | Newton | N | $\text{kg}\cdot\text{m}/\text{s}^2$ |
| Energy | Joule | J | $\text{N}\cdot\text{m}$ ($\text{kg}\cdot\text{m}^2/\text{s}^2$) |



TOTAL QUALITY MANAGEMENT



EDITED BY
P.VENKATESWARAN



978-93-6255-485-5

Total Quality Management
Copyright © 2023 by P.Venkateswaran

All rights reserved. No part of this book may be reproduced or transmitted in any form or by any means without written permission from the author.

ISBN: 978-93-6255-405-5

Publisher: PonnaiyahRamajayam Institute of Science and Technology (PRIST)

TABLE OF CONTENTS

| | |
|---|-------------|
| INTRODUCTION | -05 |
| CHAPTER 1 - TQM Principles Mrs.A.Belciya Mary | -13 |
| CHAPTER 2 -TQM Tools & Techniques I Mrs.K.Shanthi | -27 |
| CHAPTER 3 - TQM Tools & Techniques II Mr.D Jeyakumar | -41 |
| CHAPTER 4 - Quality Management System Mr.D.Amal Colins | -68 |
| CHAPTER 5 -Customer focus Mrs.R Devi | -75 |
| CHAPTER 6-System integration Mr.DJeyakumar | -88 |
| CHAPTER 7 -Base decisions on facts Mrs.A.Belciya Mary | - 112 |
| CHAPTER 8–Process approach Mr.S.Ramakrishnan | -137 |
| CHAPTER 9–Strategic and systematic approach Mr.D.AmalColins | -151 |
| CHAPTER 10-Employee involvement Mrs.R Devi | -162 |
| REFERENCES | -175 |

CHAPTER 1

TQM Principles

Mrs.A.Belciya Mary

Total Quality Management (TQM) is a holistic approach aimed at improving quality and performance in an organization. It emphasizes the importance of continuous improvement and customer satisfaction, involving all employees in the process. Here's a brief overview of its key components:

Key Concepts of TQM:

1. **Customer Orientation:** Prioritizing customer needs and expectations to enhance satisfaction.
2. **Employee Involvement:** Encouraging participation and input from all employees fosters a culture of quality and ownership.
3. **Process Improvement:** Focusing on refining processes to improve efficiency and quality.
4. **Data-Driven Decision Making:** Using facts and metrics to guide decisions and improvements.
5. **Integrated System:** Ensuring all departments work together toward common goals aligned with quality.
6. **Continuous Improvement:** Committing to ongoing enhancement of products, services, and processes.
7. **Leadership Commitment:** Strong leadership is essential for promoting and sustaining TQM practices.

Total Quality Management (TQM) is a comprehensive approach to improving organizational effectiveness through continuous quality improvement. Here are the key principles of TQM:

1. **Customer Focus:** Understanding and meeting customer needs is paramount. Organizations should prioritize customer satisfaction and feedback.
2. **Total Employee Involvement:** All employees should be engaged in the quality process. This includes fostering a culture of teamwork and encouraging input from all levels.
3. **Process-Centered Approach:** Focus on processes to improve efficiency and quality. This involves identifying, documenting, and standardizing processes.
4. **Integrated System:** Quality management should be integrated into all aspects of the organization, aligning goals and strategies across departments.
5. **Strategic and Systematic Approach:** TQM should be aligned with the organization's strategic objectives, promoting long-term success through a systematic approach to improvement.
6. **Continuous Improvement:** Organizations should strive for ongoing improvements in all areas. This can involve using tools like PDCA (Plan-Do-Check-Act) to facilitate iterative progress.
7. **Fact-Based Decision Making:** Decisions should be based on data and analysis rather than intuition alone. This involves using metrics to measure performance and inform strategies.
8. **Communication:** Open and transparent communication is essential for fostering a culture of quality and improvement. Sharing information helps align everyone towards common goals.
9. **Supplier Quality Management:** Building strong relationships with suppliers and ensuring they adhere to quality standards is critical to overall product quality.
10. **Leadership Commitment:** Leadership should actively support and participate in TQM efforts, demonstrating a commitment to quality at all levels.

CHAPTER 2

TQM Tools & Techniques I

Mrs.K. Shanthi

Total Quality Management (TQM) encompasses a range of tools and techniques aimed at improving organizational processes and ensuring customer satisfaction. Here are some key TQM tools and techniques:

1. PDCA Cycle (Plan-Do-Check-Act)

- **Plan:** Identify an opportunity for improvement and plan for change.
- **Do:** Implement the change on a small scale.
- **Check:** Use data to analyze the results of the change.
- **Act:** If successful, implement the change on a larger scale.

2. Kaizen

- Continuous improvement philosophy that encourages small, incremental changes rather than large-scale transformations.

3. Root Cause Analysis (RCA)

- Techniques like the **5 Whys** and **Fishbone Diagram** (Ishikawa) help identify the underlying causes of problems.

4. Benchmarking

- Comparing organizational processes and performance metrics to industry bests or best practices from other companies.

5. Quality Circles

- Small groups of employees who meet regularly to discuss and solve work-related problems, promoting collaboration and engagement.

6. Statistical Process Control (SPC)

- Utilizing statistical methods to monitor and control processes, helping to maintain consistent quality.

7. Flowcharts

- Visual representations of processes that help identify steps, potential bottlenecks, and areas for improvement.

8. Check Sheets

- Simple data collection tools that help identify patterns in defects or issues over time.
- Graphical tools used to determine if a process is in a state of control by analyzing variation.

CHAPTER 3

TQM Tools & Techniques II

Mr.D.Jeyakumar

Total Quality Management (TQM) emphasizes continuous improvement, customer satisfaction, and employee involvement. Here are some key tools and techniques often used in TQM:

1. Plan-Do-Check-Act (PDCA) Cycle

- **Plan:** Identify a goal or problem and develop a plan for improvement.
- **Do:** Implement the plan on a small scale.
- **Check:** Evaluate the results and compare them with the expected outcomes.
- **Act:** Standardize the successful processes or make adjustments based on findings.

2. Pareto Analysis

- A technique that focuses on identifying the most significant factors in a dataset. Often represented by the 80/20 rule, it helps prioritize issues to address.

3. Fishbone Diagram (Ishikawa)

- A visual tool that helps identify potential causes of a problem. It organizes causes into categories (e.g., people, processes, materials) for clearer analysis.

4. Flowcharts

- Used to visualize processes, making it easier to identify inefficiencies and areas for improvement.

5. Control Charts

- Statistical tools that track process performance over time. They help determine whether a process is stable and in control.

6. Root Cause Analysis (RCA)

- A method to identify the fundamental cause of problems. Techniques include the 5 Whys and Fault Tree Analysis.

7. Benchmarking

- Comparing processes and performance metrics to industry bests or best practices from other companies to identify areas for improvement.

8. Quality Audits

- Systematic examinations of a quality system to ensure compliance with standards and identify areas for enhancement.
- A data-driven approach that seeks to improve quality by identifying and removing causes of defects and minimizing variability in processes.

CHAPTER 4

Quality Management System

Mr. D.AmalColins

A Quality Management System (QMS) is a structured system that organizations use to manage and improve their processes, products, and services to ensure consistent quality and enhance customer satisfaction. Here are key components and principles of a QMS:

Key Components of a QMS

1. **Quality Policy**
 - A formal statement that outlines an organization's commitment to quality and provides a framework for setting quality objectives.
2. **Quality Objectives**
 - Specific, measurable goals that align with the quality policy and drive continuous improvement.
3. **Document Control**
 - Procedures for managing documents and records to ensure that current versions are available and obsolete documents are removed.
4. **Process Mapping**
 - Identification and mapping of key processes to ensure clarity and consistency in operations.
5. **Roles and Responsibilities**
 - Clear definition of roles, responsibilities, and authority for quality-related tasks within the organization.
6. **Training and Competence**
 - Ensuring employees are trained and competent in their roles, particularly in areas affecting product or service quality.
7. **Customer Feedback**
 - Mechanisms to gather and analyze customer feedback to drive improvements and enhance customer satisfaction.
8. **Internal Audits**
 - Regular assessments of the QMS to identify areas for improvement and ensure compliance with established standards.
9. **Management Review**
 - Periodic evaluations by top management of the QMS performance, including audits, feedback, and changes in the external environment.
10. **Corrective and Preventive Actions (CAPA)**
 - Processes for addressing non-conformities and preventing their recurrence through root cause analysis and action planning.

Principles of QMS

1. **Customer Focus**
 - Prioritizing customer needs and expectations to enhance satisfaction and loyalty.
2. **Leadership**
 - Establishing a clear vision and direction, fostering an environment where everyone is engaged in achieving quality objectives.
3. **Engagement of People**
 - Involving all employees in quality initiatives to leverage their skills and knowledge.
4. **Process Approach**
 - Understanding and managing interrelated processes to achieve consistent and predictable results.

CHAPTER 5

Customer focus

Mrs.R Devi

Customer focus is a core principle of Total Quality Management (TQM) and Quality Management Systems (QMS). It emphasizes understanding and meeting the needs and expectations of customers to enhance satisfaction and loyalty. Here are key aspects of customer focus:

Key Aspects of Customer Focus

- 1. Understanding Customer Needs**
 - Conducting market research, surveys, and feedback sessions to gather insights about customer preferences, expectations, and pain points.
- 2. Customer Segmentation**
 - Identifying different customer groups based on demographics, behaviors, and needs to tailor products and services accordingly.
- 3. Delivering Value**
 - Ensuring that products and services provide value that meets or exceeds customer expectations. This involves continuous improvement and innovation.
- 4. Effective Communication**
 - Establishing clear channels for communication with customers, including providing information about products, services, and any changes.
- 5. Responsive Service**
 - Ensuring that customer inquiries, complaints, and feedback are addressed promptly and effectively.
- 6. Building Relationships**
 - Fostering long-term relationships with customers through personalized service and engagement strategies.
- 7. Customer Feedback Loop**
 - Implementing systems to regularly collect, analyze, and act on customer feedback to drive improvements.
- 8. Empowering Employees**
 - Training and empowering employees to make decisions that enhance customer experience and satisfaction.
- 9. Measuring Satisfaction**
 - Using metrics such as Net Promoter Score (NPS), Customer Satisfaction Score (CSAT), and Customer Effort Score (CES) to gauge customer satisfaction and loyalty.
- 10. Continuous Improvement**
 - Adopting a mindset of ongoing improvement based on customer feedback and changing market conditions.

Benefits of Customer Focus

- **Increased Customer Loyalty:** Satisfied customers are more likely to return and recommend your products or services.
- **Competitive Advantage:** Understanding and meeting customer needs can differentiate your business in a crowded market.
- **Enhanced Reputation:** Companies known for customer focus often enjoy a stronger brand reputation.
- **Higher Revenue:** Satisfied customers can lead to increased sales through repeat business and referrals. Visualizing the customer experience from awareness to post-purchase to identify touchpoints for improvement.

CHAPTER 6

System integration

Mr. D Jeyakumar

System integration refers to the process of combining different subsystems or components into a single, unified system that functions cohesively. This is crucial for organizations looking to enhance efficiency, improve data flow, and streamline operations. Here's an overview of key concepts, benefits, and approaches to system integration:

Key Concepts

1. **Subsystems**
 - Independent systems or components that perform specific functions within an organization, such as CRM, ERP, and supply chain management systems.
2. **Interoperability**
 - The ability of different systems and organizations to work together and share data seamlessly.
3. **Data Flow**
 - Ensuring that data can move freely between integrated systems, enabling better decision-making and reporting.
4. **Unified Interface**
 - Providing users with a single interface to interact with multiple systems, simplifying processes and reducing training time.

Benefits of System Integration

1. **Improved Efficiency**
 - Streamlined processes reduce duplication of effort and minimize manual data entry.
2. **Enhanced Data Accuracy**
 - Integration reduces errors associated with transferring data between systems manually.
3. **Better Decision-Making**
 - Access to real-time data from integrated systems supports more informed and timely decisions.
4. **Cost Savings**
 - Increased efficiency and reduced errors can lead to significant cost reductions over time.
5. **Scalability**
 - A well-integrated system can easily adapt to changing business needs and accommodate growth.
6. **Enhanced Customer Experience**
 - Seamless access to information allows for better customer service and faster response times.

Approaches to System Integration

1. **Point-to-Point Integration**
 - Direct connections between individual systems. This is simple but can become complex and unmanageable as more systems are added.
2. **Middleware Solutions**
 - Software that acts as a bridge between different applications, facilitating communication and data exchange.
3. **Enterprise Service Bus (ESB)**
 - A more advanced middleware architecture that enables integration through a centralized hub, allowing various services to communicate efficiently.
4. **Application Programming Interfaces (APIs)** APIs allow different systems to communicate and share data, providing flexibility and scalability in integration.

CHAPTER 7

Base decisions on facts

Mrs.A.Belciya Mary

Basing decisions on facts is a critical principle in effective management and quality practices. This approach emphasizes the use of data and evidence to inform decision-making, leading to more reliable outcomes. Here are key elements of this principle:

Key Elements of Fact-Based Decision Making

- 1. Data Collection**
 - Gather relevant and accurate data from various sources, including customer feedback, operational metrics, market research, and performance indicators.
- 2. Data Analysis**
 - Use statistical tools and techniques to analyze the collected data, identifying trends, patterns, and insights that inform decision-making.
- 3. Objective Evaluation**
 - Assess options and potential outcomes objectively, minimizing biases and relying on evidence rather than intuition or assumptions.
- 4. Performance Metrics**
 - Establish clear metrics to evaluate success and performance. This could include KPIs (Key Performance Indicators) that align with organizational goals.
- 5. Scenario Planning**
 - Consider different scenarios and outcomes based on factual data, allowing for more robust decision-making and risk management.
- 6. Continuous Monitoring**
 - Regularly review data and outcomes to ensure decisions remain relevant and adjust strategies as needed based on new information.

Benefits of Fact-Based Decision Making

- 1. Increased Accuracy**
 - Decisions based on solid data are more likely to lead to successful outcomes, reducing the risk of errors.
- 2. Enhanced Accountability**
 - Using facts makes it easier to justify decisions to stakeholders, fostering transparency and trust.
- 3. Improved Efficiency**
 - Streamlined decision-making processes based on factual evidence can save time and resources.
- 4. Better Risk Management**
 - Understanding data and trends allows organizations to identify potential risks and mitigate them proactively.
- 5. Alignment with Goals**
 - Fact-based decisions help ensure that actions are aligned with strategic objectives and customer needs.

Tools and Techniques for Fact-Based Decision Making

Business Intelligence (BI) Tools

- Software that analyzes data and presents actionable information, enabling informed decision-making.

CHAPTER 8

Process approach

Mr.S.Ramakrishnan

The **process approach** is a key principle of quality management that emphasizes the importance of understanding and managing interrelated processes to achieve desired outcomes efficiently and effectively. Here's a deeper look into the process approach, its benefits, and how to implement it.

Key Concepts of the Process Approach

- 1. Definition of Processes**
 - A process is a set of interrelated or interacting activities that transforms inputs into outputs. Each process contributes to the overall performance of the organization.
- 2. Process Mapping**
 - Visualizing processes through flowcharts or diagrams to understand workflows, identify interactions, and spot inefficiencies.
- 3. Input-Output Model**
 - Recognizing that processes take inputs (resources, information) and produce outputs (products, services) that meet customer needs.
- 4. Process Interactions**
 - Understanding how different processes interact and affect one another, leading to a holistic view of operations.

Benefits of the Process Approach

- 1. Improved Efficiency**
 - By optimizing processes, organizations can eliminate waste, reduce cycle times, and lower costs.
- 2. Enhanced Quality**
 - A structured approach helps ensure consistency in processes, leading to higher quality products and services.
- 3. Greater Customer Satisfaction**
 - Efficient processes can improve response times and service delivery, enhancing customer experiences.
- 4. Clear Accountability**
 - Defining processes establishes clear roles and responsibilities, making it easier to manage performance.
- 5. Continuous Improvement**
 - The process approach fosters a culture of continuous improvement by regularly reviewing and optimizing processes.

Steps to Implement a Process Approach

- 1. Identify Core Processes**
 - Determine the key processes that are essential to achieving organizational objectives.
- 2. Map and Analyze Processes**
 - Create detailed process maps to visualize workflows, identify bottlenecks, and assess performance.
- 3. Define Objectives and Metrics**
 - Establish clear goals for each process and identify metrics to measure performance against these objectives.
- 4. Engage Employees** Involve employees at all levels in the mapping and improvement process, as they often have valuable insights into daily operations.

CHAPTER 9

Strategic and systematic approach

Mr.D.Amal Colins

A strategic and systematic approach involves clearly defining goals and objectives, analyzing the current situation, and creating a structured plan to achieve desired outcomes. Here's a breakdown of the process:

1. Define Objectives

- Set specific, measurable, achievable, relevant, and time-bound (SMART) goals.

2. Situation Analysis

- Conduct a SWOT analysis (Strengths, Weaknesses, Opportunities, Threats) to assess internal and external factors.

3. Develop Strategies

- Identify strategic options based on the analysis.
- Consider resource allocation, risk management, and potential impacts.

4. Create an Action Plan

- Outline detailed steps, timelines, and responsibilities.
- Ensure alignment with the overall strategy.

5. Implementation

- Execute the action plan with clear communication and support.
- Utilize project management tools to track progress.

6. Monitoring and Evaluation

- Regularly review performance against objectives.
- Adjust strategies and tactics as needed based on feedback and results.

7. Continuous Improvement

- Foster a culture of learning and adaptation to refine processes and strategies over time.

This structured approach helps ensure that efforts are coordinated, resources are optimized, and outcomes are effectively achieved. Would you like to delve into a specific area of this process.

CHAPTER 10

Employee involvement

Mrs. R.Devi

Employee involvement is crucial for fostering a positive workplace culture and enhancing organizational performance. Here are some effective strategies to encourage employee involvement:

1. Encourage Open Communication

- Foster a culture where employees feel safe sharing their ideas and concerns.
- Use regular check-ins, feedback sessions, and suggestion boxes.

2. Empower Decision-Making

- Involve employees in decision-making processes related to their work.
- Delegate authority where appropriate, allowing team members to take ownership of projects.

3. Provide Opportunities for Development

- Offer training, workshops, and mentorship programs to help employees grow.
- Encourage participation in cross-functional teams and projects.

4. Recognize and Reward Contributions

- Acknowledge individual and team achievements publicly.
- Implement incentive programs that align with company goals.

5. Solicit Feedback Regularly

- Conduct employee surveys to gauge satisfaction and gather input on policies and practices.
- Act on feedback to show that employee opinions matter.

6. Create Collaborative Work Environments

- Foster teamwork through collaborative tools and spaces.
- Encourage knowledge sharing and joint problem-solving.

7. Set Clear Goals and Expectations

- Ensure that employees understand how their roles contribute to organizational objectives.
- Align personal goals with the company's mission.

8. Involve Employees in Change Management

- Engage employees in discussions about changes and innovations.
- Include them in planning and implementing new initiatives.

9. Promote Work-Life Balance

- Encourage flexible work arrangements and support employee well-being.
- Respect personal time and boundaries to prevent burnout.



AIRPORTS AND HARBOURS

EDITED BY

J.SANTHIYAA JENIFER



978-93-6255-495-6

Airports and Harbours
Copyright © 2023 by J.Santhiyaa Jenifer

All rights reserved. No part of this book may be reproduced or transmitted in any form or by any means without written permission from the author.

ISBN: 978-93-6255-126-9

Publisher: PonnaiyahRamajayam Institute of Science and Technology (PRIST)

TABLE OF CONTENTS

| | |
|--|-------------|
| INTRODUCTION | -05 |
| CHAPTER 1 - Airport Planning Mrs.A.Belciya Mary | -13 |
| CHAPTER 2 -Airport Components Mrs.K.Shanthi | -27 |
| CHAPTER 3 - Airport Design Mr.D.Jeyakumar | -41 |
| CHAPTER 4 - Seaports Components and Construction Mr.D.AmalColins | -68 |
| CHAPTER 5 -Seaport Regulations and EIA Mrs.R Devi | -75 |
| CHAPTER 6-Harbor planning Mr.DJeyakumar | -88 |
| CHAPTER 7 -Technical visits Mrs.A.Belciya Mary | - 112 |
| CHAPTER 8–Ports Mr.S.Ramakrishnan | -137 |
| CHAPTER 9–Air Traffic Management Mr.D.AmalColins | -151 |
| CHAPTER 10-Harbor Operations Mrs.R Devi | -162 |
| REFERENCES | -180 |

CHAPTER 1

Airport Planning

Mrs.A.Belciya Mary

Airport planning is a complex process that involves various factors to ensure efficient, safe, and sustainable operations. Here are some key aspects of airport planning:

1. Site Selection

- **Geographical Considerations:** Proximity to urban areas, topography, and environmental impact.
- **Accessibility:** Connectivity to major roadways and public transport options.

2. Master Planning

- **Long-Term Vision:** Establishing a comprehensive plan that outlines future expansions and developments.
- **Zoning Regulations:** Compliance with local, state, and federal regulations.

3. Capacity Analysis

- **Passenger Demand Forecasting:** Estimating future air traffic and passenger volumes.
- **Runway and Taxiway Capacity:** Evaluating the current infrastructure against projected growth.

4. Design and Layout

- **Terminal Design:** Creating user-friendly spaces for passengers, including check-in, security, and boarding areas.
- **Runway Configuration:** Optimizing runway orientation for prevailing winds and safety.

5. Environmental Considerations

- **Impact Assessments:** Evaluating effects on local ecosystems and communities.
- **Sustainability Practices:** Implementing green technologies and noise abatement strategies.

6. Financial Planning

- **Funding Sources:** Identifying public and private funding opportunities.
- **Cost-Benefit Analysis:** Evaluating the economic feasibility of proposed projects.

7. Regulatory Compliance

- **FAA Regulations:** Adhering to Federal Aviation Administration standards and guidelines.
- **International Standards:** Following ICAO regulations for international airports.

8. Community Engagement

- **Public Consultations:** Engaging with local communities to address concerns and gather input.
- **Partnerships:** Collaborating with stakeholders, including airlines and government agencies.

CHAPTER 2

Airport Components

Mrs.K.Shanthi

Airport components can be categorized into several key areas that facilitate the operations, safety, and efficiency of air travel. Here's an overview of the main components of an airport:

1. Runways

- **Primary Function:** Takeoff and landing of aircraft.
- **Design Features:** Length, width, surface materials, and markings for safe operations.

2. Taxiways

- **Function:** Connect runways with terminals, hangars, and other facilities.
- **Layout Considerations:** Adequate width, signage, and lighting for safe navigation.

3. Terminals

- **Passenger Areas:** Check-in counters, security screening, boarding gates, and baggage claim.
- **Amenities:** Shops, restaurants, lounges, and services to enhance passenger experience.

4. Control Towers

- **Function:** Air traffic control and management.
- **Role:** Ensure safe takeoff, landing, and taxiing of aircraft.

5. Hangars

- **Purpose:** Storage and maintenance of aircraft.
- **Features:** Space for repairs, inspections, and servicing.

6. Cargo Facilities

- **Function:** Handling and processing of air cargo.
- **Components:** Warehousing, loading docks, and customs clearance areas.

7. Parking Areas

- **Types:** Short-term, long-term, and employee parking.
- **Design:** Efficient layout to accommodate different vehicle types.

8. Ground Support Equipment (GSE)

- **Types:** Baggage tugs, fuel trucks, pushback tractors, and maintenance vehicles.
- **Role:** Assist in loading/unloading and servicing aircraft.

9. Security Infrastructure

- **Components:** Screening areas, security checkpoints, and surveillance systems.
- **Function:** Ensure safety and compliance with regulations.

CHAPTER 3

Airport Design

Mr.D.Jeyakumar

Airport components can be categorized into several key areas that facilitate the operations, safety, and efficiency of air travel. Here's an overview of the main components of an airport:

1. Runways

- **Primary Function:** Takeoff and landing of aircraft.
- **Design Features:** Length, width, surface materials, and markings for safe operations.

2. Taxiways

- **Function:** Connect runways with terminals, hangars, and other facilities.
- **Layout Considerations:** Adequate width, signage, and lighting for safe navigation.

3. Terminals

- **Passenger Areas:** Check-in counters, security screening, boarding gates, and baggage claim.
- **Amenities:** Shops, restaurants, lounges, and services to enhance passenger experience.

4. Control Towers

- **Function:** Air traffic control and management.
- **Role:** Ensure safe takeoff, landing, and taxiing of aircraft.

5. Hangars

- **Purpose:** Storage and maintenance of aircraft.
- **Features:** Space for repairs, inspections, and servicing.

6. Cargo Facilities

- **Function:** Handling and processing of air cargo.
- **Components:** Warehousing, loading docks, and customs clearance areas.

7. Parking Areas

- **Types:** Short-term, long-term, and employee parking.
- **Design:** Efficient layout to accommodate different vehicle types.

8. Ground Support Equipment (GSE)

- **Types:** Baggage tugs, fuel trucks, pushback tractors, and maintenance vehicles.
- **Role:** Assist in loading/unloading and servicing aircraft.

9. Security Infrastructure

- **Components:** Screening areas, security checkpoints, and surveillance systems.
- **Function:** Ensure safety and compliance with regulations.

CHAPTER 4

Seaports Components and Construction

Mr. D.AmalColins

Seaports are complex facilities designed to facilitate maritime transportation, cargo handling, and passenger services. Here's a breakdown of the key components and considerations involved in seaport construction:

Key Components of Seaports

- Berths**
 - **Function:** Designated docking areas for vessels to load and unload cargo or passengers.
 - **Types:** Container, bulk, and roll-on/roll-off (RoRo) berths.
- Quays and Wharfs**
 - **Structure:** Platforms built along the waterfront where ships are moored.
 - **Design Considerations:** Must support the weight of cargo and withstand tidal changes.
- Cargo Handling Facilities**
 - **Containers:** Specialized facilities for containerized cargo, including cranes and stacking areas.
 - **Bulk Cargo:** Systems for handling bulk materials like grain, coal, or liquids, often with silos or tanks.
- Storage Areas**
 - **Warehousing:** Indoor storage for goods awaiting transportation or processing.
 - **Open Storage:** Outdoor areas for stacking containers or bulk materials.
- Access Roads and Transportation Links**
 - **Road Networks:** Connecting the port to highways and cities for efficient cargo movement.
 - **Rail Connections:** Integrating rail systems for intermodal transport of goods.
- Navigation Aids**
 - **Buoys and Markers:** Used to guide vessels safely into and out of the port.
 - **Traffic Control Systems:** Radar and communication systems to manage vessel movements.
- Security Infrastructure**
 - **Fencing and Access Control:** Ensuring only authorized personnel can enter sensitive areas.
 - **Surveillance Systems:** Cameras and monitoring systems for security and safety.
- Passenger Terminals**
 - **Cruise and Ferry Terminals:** Facilities designed for passengers, including waiting areas, ticketing, and amenities.
 - **Customs and Immigration:** Areas for processing international travelers.
- Emergency Services**
 - **Fire and Rescue Facilities:** Services equipped to handle maritime emergencies.
 - **Medical Services:** Access to medical care for crew and passengers.

Construction Considerations

- Site Selection**
 - **Geography:** Choosing locations with natural deep-water access to accommodate larger vessels.
 - **Environmental Impact:** Assessing potential effects on marine ecosystems and local communities.
- Design and Engineering**
 - **Hydraulic Engineering:** Designing structures to withstand water levels, tides, and wave action.
 - **Structural Integrity:** Ensuring all components can support the weight and stresses of cargo and vessels.

CHAPTER 5

Seaport Regulations and EIA

Mrs.R Devi

Seaports operate under a framework of regulations and environmental assessments to ensure safety, security, and environmental protection. Here's an overview of seaport regulations and the Environmental Impact Assessment (EIA) process:

Seaport Regulations

1. International Regulations

- **International Maritime Organization (IMO):** Sets global standards for the safety, security, and environmental performance of international shipping.
- **SOLAS (Safety of Life at Sea):** Establishes safety standards for ships, including construction, equipment, and operation.

2. National Regulations

- **Maritime Administration:** Governs port operations, vessel licensing, and safety regulations at the national level.
- **Coast Guard Regulations:** Enforce safety and security measures, including vessel inspections and emergency response protocols.

3. Environmental Regulations

- **Clean Water Act:** Regulates discharges into U.S. waters, requiring permits for activities that may impact water quality.
- **National Environmental Policy Act (NEPA):** Requires federal agencies to assess the environmental effects of their proposed actions, including port development.

4. Security Regulations

- **Transportation Security Administration (TSA):** Enforces security measures for passenger and cargo terminals.
- **MTSA (Maritime Transportation Security Act):** Mandates security plans for ports and vessels to mitigate potential threats.

5. Health and Safety Regulations

- **Occupational Safety and Health Administration (OSHA):** Establishes workplace safety standards for port employees.
- **Hazardous Materials Regulations:** Govern the handling, storage, and transportation of dangerous goods.

Environmental Impact Assessment (EIA)

1. Purpose of EIA

- **Assess Environmental Effects:** Evaluate the potential impacts of proposed projects on the environment, including air, water, land, and ecosystems.
- **Informed Decision-Making:** Provide information to decision-makers and the public about the environmental consequences of proposed activities.

2. EIA Process

- **Screening:** Determine whether a project requires a full EIA based on its potential impacts and regulatory requirements.
- **Scoping:** Identify key issues and concerns to be addressed in the assessment, often involving public consultations.
- **Impact Analysis:** Evaluate potential environmental impacts, including direct, indirect, and cumulative effects.
- **Mitigation Measures:** Propose measures to minimize or offset negative impacts on the environment.

CHAPTER 6

Harbor planning

-

Mr. D Jeyakumar

Harbor planning is a comprehensive process that involves the design, development, and management of harbor facilities to ensure safe and efficient maritime operations. Here are the key aspects of harbor planning:

1. Site Selection

- **Geographical Considerations:** Assessing natural features such as water depth, shoreline, and protection from severe weather.
- **Accessibility:** Evaluating proximity to shipping routes, land transport links, and urban areas.

2. Hydraulic and Structural Design

- **Breakwaters and Jetties:** Designing structures to protect the harbor from waves and currents.
- **Dredging Plans:** Establishing plans for maintaining adequate water depths for vessel navigation.

3. Layout and Infrastructure

- **Berths and Docks:** Designing docking facilities for various types of vessels (e.g., cargo ships, fishing boats, ferries).
- **Cargo Handling Facilities:** Planning areas for loading, unloading, and storing cargo, including cranes and warehouses.

4. Environmental Considerations

- **Impact Assessments:** Conducting Environmental Impact Assessments (EIAs) to evaluate potential effects on local ecosystems and communities.
- **Sustainability Practices:** Incorporating green technologies and practices to minimize environmental impact.

5. Transportation Links

- **Road and Rail Connections:** Planning access routes to facilitate the movement of goods to and from the harbor.
- **Public Transport Integration:** Ensuring connectivity for passengers traveling to and from the harbor.

6. Safety and Security Measures

- **Navigation Aids:** Implementing buoys, lights, and radar systems to assist vessels in navigating safely.
- **Security Infrastructure:** Establishing protocols and facilities for security screening and surveillance.

CHAPTER 7

Technical visits

Mrs.A.Belciya Mary

Technical visits are organized excursions to facilities, sites, or organizations related to specific fields of interest, such as engineering, transportation, or environmental management. They provide participants with practical insights, hands-on experiences, and the opportunity to observe real-world applications of theoretical concepts. Here's an overview of the key aspects and benefits of technical visits:

Key Aspects of Technical Visits

1. Purpose and Objectives

- **Learning Opportunity:** To enhance understanding of specific technologies, processes, or practices.
- **Networking:** To connect with industry professionals, experts, and peers.

2. Planning and Preparation

- **Site Selection:** Choosing locations relevant to the participants' field of study or professional interests (e.g., ports, airports, manufacturing facilities).
- **Logistics:** Organizing transportation, accommodation, and schedules for the visit.
- **Safety and Compliance:** Ensuring participants understand safety protocols and any necessary compliance regulations.

3. Guided Tours

- **Expert Guidance:** Providing knowledgeable guides or company representatives to explain processes and answer questions.
- **Structured Itinerary:** Designing a schedule that allows for comprehensive coverage of key areas or technologies.

4. Hands-On Activities

- **Demonstrations:** Opportunities to observe live demonstrations of equipment or processes.
- **Interactive Sessions:** Engaging participants in discussions or workshops to deepen their understanding.

5. Documentation and Feedback

- **Observation Reports:** Encouraging participants to take notes and document key learnings.
- **Feedback Sessions:** Facilitating discussions after the visit to reflect on insights gained and experiences shared.

Benefits of Technical Visits

1. Real-World Insight

- Participants gain firsthand knowledge of industry practices, technologies, and challenges.

2. Application of Theory

- Helps bridge the gap between academic learning and practical application in real-world scenarios.

3. Enhanced Learning Experience

- Visual and experiential learning can reinforce concepts taught in classrooms or training programs.

4. Networking Opportunities

- Provides a platform to meet industry professionals, fostering potential collaborations or mentorships.

5. Inspiration and Motivation

- Exposure to innovative practices and technologies can inspire participants to pursue their careers more passionately.

CHAPTER 8

Ports

Mr.S.Ramakrishnan

Ports are critical infrastructure facilities that serve as gateways for international trade, facilitating the movement of goods and passengers between land and sea. Here's a comprehensive overview of ports, including their functions, types, components, and significance:

Functions of Ports

- 1. Cargo Handling**
 - **Loading and Unloading:** Ports manage the transfer of cargo between ships and shore facilities.
 - **Storage:** Provide warehousing and open storage areas for goods.
- 2. Passenger Services**
 - **Cruise Terminals:** Facilitate passenger boarding and disembarkation for cruise ships.
 - **Ferry Services:** Operate routes for passenger and vehicle transportation.
- 3. Customs and Regulations**
 - **Customs Clearance:** Handle import and export documentation and inspections.
 - **Regulatory Compliance:** Ensure adherence to safety, security, and environmental standards.
- 4. Intermodal Transportation**
 - **Connectivity:** Serve as hubs connecting maritime transport with rail and road networks for seamless cargo movement.
- 5. Economic Development**
 - **Job Creation:** Support local economies through employment opportunities in logistics, shipping, and related industries.
 - **Trade Facilitation:** Enhance international trade by providing efficient transport links.

Types of Ports

- 1. Seaports**
 - **Commercial Ports:** Handle cargo and shipping activities for trade (e.g., container ports).
 - **Fishing Ports:** Support the fishing industry, providing facilities for docking and processing.
- 2. River Ports**
 - Located along rivers, these ports handle inland shipping and often serve as transfer points for goods moving to and from the sea.
- 3. Marinas**
 - Facilities designed for recreational boating, offering docking, maintenance, and services for private vessels.
- 4. Specialized Ports**
 - **Bulk Ports:** Focus on handling bulk cargo like coal, grain, and liquids.
 - **Ro-Ro Ports:** Specialized for roll-on/roll-off vessels that transport vehicles.

Key Components of Ports

- 1. Berths and Docks**
 - Areas where ships are moored for loading and unloading cargo or passengers.
- 2. Cargo Handling Facilities**
 - Cranes, conveyors, and other equipment used for efficient cargo transfer.
- 3. Storage Facilities**
 - Warehouses and open storage areas for temporary holding of goods.
- 4. Transportation Links**
 - Roads, rail lines, and other infrastructure that connect the port to inland destinations.

CHAPTER 9

Air Traffic Management

Mr.D.AmalColins

Air Traffic Management (ATM) is a crucial component of the aviation system, responsible for ensuring the safe, orderly, and efficient movement of aircraft in the airspace and at airports. Here's a comprehensive overview of air traffic management, its components, functions, and challenges:

Key Components of Air Traffic Management

- 1. Air Traffic Control (ATC)**
 - **En-route Control:** Manages aircraft flying between departure and destination airports, ensuring safe separation and efficient routing.
 - **Terminal Control:** Manages aircraft during the approach and departure phases around airports, including both arrival and departure air traffic control.
- 2. Flight Information Services (FIS)**
 - Provides pilots with essential information such as weather updates, airspace restrictions, and navigation aid status.
- 3. Airspace Management**
 - **Classification:** Divides airspace into various classes (e.g., Class A, B, C) based on the type of operations and levels of air traffic control required.
 - **Design:** Involves planning and organizing airspace structures to optimize traffic flow and safety.
- 4. Communication Systems**
 - **Radio Communication:** Facilitates communication between pilots and air traffic controllers using VHF radio frequencies.
 - **Data Communication:** Enhances communication capabilities through technologies like Automatic Dependent Surveillance–Broadcast (ADS-B) and Controller Pilot Data Link Communications (CPDLC).
- 5. Surveillance Systems**
 - **Radar Systems:** Used for tracking the position and movement of aircraft in real time.
 - **Satellite-Based Systems:** Offer more precise tracking and information, improving situational awareness.
- 6. Navigation Systems**
 - **Ground-Based Aids:** Includes VOR (VHF Omnidirectional Range) and NDB (Non-Directional Beacon) for aircraft navigation.
 - **Global Navigation Satellite Systems (GNSS):** Such as GPS, provide accurate positioning and navigation capabilities.
- 7. Traffic Flow Management (TFM)**
 - Ensures that air traffic is managed efficiently to prevent congestion and delays, particularly during peak periods.

Functions of Air Traffic Management

- 1. Safety Assurance**
 - Maintaining safe separation between aircraft to prevent collisions and incidents.
- 2. Efficient Routing**
 - Optimizing flight paths to minimize delays and fuel consumption, thereby reducing costs and environmental impact.
- 3. Crisis Management**
 - Implementing emergency procedures for unexpected events, such as severe weather or system failures.

CHAPTER 10

Harbor Operations

Mrs.R Devi

Harbor operations encompass a range of activities and processes involved in the efficient management of ports and harbors. These operations are critical for facilitating the movement of goods and passengers between land and sea. Here's a comprehensive overview of harbor operations, including their key components, functions, and challenges:

Key Components of Harbor Operations

1. Berthing and Mooring

- **Berths:** Designated spaces where vessels dock to load and unload cargo or passengers.
- **Mooring Systems:** Equipment (e.g., ropes, fenders, and mooring buoys) that secure vessels in place.

2. Cargo Handling

- **Loading and Unloading:** Operations involving cranes, forklifts, and conveyor systems to transfer goods between ships and shore facilities.
- **Types of Cargo:** Handling various cargo types, including containers, bulk materials, and roll-on/roll-off vehicles.

3. Storage Facilities

- **Warehouses:** Indoor spaces for temporary storage of goods.
- **Open Storage Areas:** Outdoor spaces for stacking containers or bulk materials.

4. Transportation Links

- **Road Networks:** Connecting the harbor to local and regional road systems for efficient cargo distribution.
- **Rail Connections:** Integrating rail transport for intermodal shipping.

5. Customs and Regulatory Compliance

- **Customs Clearance:** Processes for inspecting and clearing goods for import and export.
- **Regulatory Compliance:** Ensuring adherence to safety, environmental, and security regulations.

6. Safety and Security Measures

- **Surveillance Systems:** Monitoring equipment to enhance security and safety.
- **Emergency Response Plans:** Procedures for managing emergencies, such as spills or accidents.

Functions of Harbor Operations

1. Facilitating Trade

- Harbor operations are essential for the import and export of goods, supporting local and global economies.

2. Passenger Services

- Managing passenger terminals for cruise ships and ferries, providing ticketing, boarding, and amenities.

3. Efficient Traffic Management

- Coordinating vessel movements in and out of the harbor to minimize congestion and delays.

4. Maintenance of Infrastructure

- Regular upkeep of berths, docks, and cargo handling equipment to ensure operational efficiency and safety.

5. Environmental Management

- Implementing practices to minimize the environmental impact of harbor activities, such as pollution control and waste management.

-

HYDROLOGY AND WATER RESOURCE ENGINEERING

EDITED BY

DR.P.PARAMAGURU



978-93-6255-785-8

Hydrology and Water Resource Engineering
Copyright © 2023 by Dr.P.Paramaguru

All rights reserved. No part of this book may be reproduced or transmitted in any form or by any means without written permission from the author.

ISBN: 978-93-6255-785-8

Publisher: PonnaiyahRamajayam Institute of Science and Technology (PRIST)

TABLE OF CONTENTS

| | | |
|--|---|-----|
| INTRODUCTION | - | 05 |
| CHAPTER 1- Precipitation and Abstractions Mr.P.Venkateswaran | - | 12 |
| CHAPTER 2 -Runoff Mrs.J.Santhiyaa Jenifer | - | 27 |
| CHAPTER 3 -Hydrological Extremes Mrs.R.Devi | - | 34 |
| CHAPTER 4 -Reservoirs Mrs.Iraikarkuzhali | - | 52 |
| CHAPTER 5-Groundwater and Management Mr.D.Jeyakumar | - | 70 |
| CHAPTER 6-Management of water resources Mrs.M.Karpagam | - | 86 |
| CHAPTER 7-Groundwater Technology Mrs.K.Shanthi | - | 110 |
| CHAPTER 8-Storm water management Mrs.T.Vidhudhalai | - | 122 |
| CHAPTER 9-Water quality Mr.D.Amal Colins | - | 131 |
| CHAPTER 10-Sustainable water supply systems Mrs.R Devi | - | 150 |
| REFERENCES | | 170 |

CHAPTER 1

Precipitation and Abstractions

Mr.P.Venkateswaran

Precipitation and **abstractions** are key concepts in hydrology and water resource management, crucial for understanding the water cycle and managing water resources effectively. Here's a detailed look at both:

Precipitation

Precipitation refers to any form of water that falls from the atmosphere to the Earth's surface. It is a crucial component of the hydrological cycle and includes various forms:

Types of Precipitation:

- **Rain:** Liquid water droplets that fall when atmospheric conditions are warm enough.
- **Snow:** Ice crystals that form and fall when temperatures are below freezing.
- **Sleet:** Small pellets of ice that occur when rain falls through a layer of cold air and freezes.
- **Hail:** Hard, rounded pellets of ice that form in severe thunderstorms with strong updrafts.
- **Drizzle:** Fine droplets of water that fall slowly and are smaller than typical rain droplets.
- **Freezing Rain:** Rain that falls as liquid but freezes upon contact with cold surfaces.

Measurement and Analysis:

- **Rain Gauges:** Instruments used to measure the amount of precipitation over a specific period. Types include standard rain gauges, tipping bucket gauges, and radar-based systems.
- **Precipitation Intensity:** The rate at which precipitation occurs, typically measured in millimeters per hour (mm/hr) or inches per hour (in/hr).
- **Precipitation Duration and Frequency:** The length of time precipitation lasts and how often it occurs. These factors are important for designing drainage systems and understanding water supply.

Abstractions

Abstractions refer to the portion of precipitation that does not directly contribute to runoff or groundwater recharge. It encompasses various processes and losses that occur before the water reaches streams, rivers, or aquifers.

Types of Abstractions:

- **Evaporation:** The process by which water is converted from liquid to vapor and returns to the atmosphere. It includes:
 - **Soil Evaporation:** Water evaporating directly from the soil surface.
 - **Plant Transpiration:** Water vapor released by plants into the atmosphere through their leaves.
 - **Combined Evapotranspiration:** The total amount of water lost to the atmosphere from both evaporation and transpiration.
- **Infiltration:** The process by which water enters the soil and becomes part of the groundwater system. The rate of infiltration depends on soil properties, land use, and vegetation cover.

CHAPTER 2

Runoff

Mrs.J.Santhiyaa Jenifer

Runoff refers to the portion of precipitation that flows over the ground surface and eventually makes its way into streams, rivers, lakes, and oceans. It is a key component of the hydrological cycle and plays a critical role in water resource management, flood control, and environmental conservation.

Key Concepts of Runoff

1. Types of Runoff

- **Surface Runoff:** Water that flows over the ground surface directly into water bodies. It occurs when the precipitation rate exceeds the soil's infiltration capacity or when the ground is already saturated.
- **Subsurface Runoff:** Also known as **interflow**, this is water that moves through the soil layer above the groundwater table and eventually discharges into streams or rivers.
- **Baseflow:** The portion of runoff that comes from groundwater discharge into streams and rivers, providing a sustained flow even during dry periods.

2. Factors Influencing Runoff

- **Precipitation Intensity and Duration:** Higher intensity and longer duration of rainfall lead to increased runoff. Intense rainfall can exceed the soil's infiltration capacity, resulting in greater surface runoff.
- **Soil Characteristics:** Soil properties such as texture, structure, and permeability affect how much water infiltrates versus how much runs off. Sandy soils, for example, tend to have higher infiltration rates than clayey soils.
- **Land Use and Vegetation:** Vegetation and land cover significantly impact runoff. Vegetated areas and natural landscapes (like forests and grasslands) reduce runoff by increasing infiltration and interception. Urban areas with impervious surfaces (like roads and buildings) increase runoff.
- **Topography:** The slope and shape of the land affect runoff. Steeper slopes generally result in faster runoff, while flat areas allow more time for infiltration.
- **Soil Moisture:** Pre-existing soil moisture levels influence runoff. Saturated soils have reduced infiltration capacity, leading to increased runoff.
- **Land Management Practices:** Practices such as deforestation, urbanization, and agriculture can alter runoff patterns by changing the land surface and vegetation cover.

3. Runoff Measurement and Modeling

- **Measurement:** Runoff is typically measured using stream gauges, rain gauges, and other hydrological instruments. The volume and rate of runoff can be measured at various points in a watershed.
- **Hydrological Models:** Models are used to simulate runoff and predict how different factors (like land use changes or rainfall events) will affect runoff. Examples include:
 - **SCS-CN (Soil Conservation Service Curve Number) Method:** A commonly used method that estimates runoff based on rainfall, soil type, land use, and hydrologic conditions.
 - **HEC-HMS (Hydrologic Modeling System):** A comprehensive software developed by the U.S. Army Corps of Engineers for simulating the hydrological cycle and runoff.

CHAPTER 3

Hydrological Extremes

Mrs.R.Devi

Hydrological extremes refer to unusual and extreme events in the water cycle that deviate significantly from the norm. These extremes can have substantial impacts on water resources, ecosystems, infrastructure, and human activities. They are typically categorized into two main types: extreme wet events and extreme dry events.

Extreme Wet Events

Extreme wet events involve excessive precipitation, which can lead to significant hydrological consequences. Key examples include:

A. Floods

- **Flash Floods:** Sudden, intense floods that occur within minutes to hours of heavy rainfall, often in small, localized areas. They are characterized by rapid rises in water levels and can be triggered by intense storms, dam failures, or rapid snowmelt.
- **River Floods:** Occur when rivers overflow their banks due to prolonged heavy rainfall, snowmelt, or a combination of both. These floods can last for days or weeks and affect larger areas.
- **Coastal Floods:** Result from storm surges, high tides, or tsunamis impacting coastal areas. They can cause significant damage to coastal communities and infrastructure.
- **Urban Floods:** Occur in cities where impervious surfaces (like roads and buildings) prevent water from infiltrating, leading to rapid runoff and localized flooding.

B. Heavy Rainfall Events

- **Extreme Rainfall:** Refers to unusually high amounts of precipitation over a short period, such as in intense thunderstorms or hurricanes. These events can overwhelm drainage systems and lead to flooding.

C. Tropical Cyclones

- **Hurricanes, Typhoons, and Cyclones:** Large, powerful storm systems that bring heavy rain, strong winds, and storm surges. They can cause widespread flooding, damage infrastructure, and disrupt communities.

Extreme Dry Events

Extreme dry events involve conditions of insufficient precipitation, which can lead to water shortages and other related issues. Key examples include:

A. Droughts

- **Meteorological Drought:** Extended periods of below-average precipitation relative to historical norms.
- **Agricultural Drought:** Occurs when there is insufficient moisture to meet the needs of crops and livestock, leading to reduced agricultural yields.

CHAPTER 4

Reservoirs

Mrs.Iraikarkuzhali

Reservoirs are artificial or natural lakes created to store water for various purposes, including water supply, flood control, irrigation, hydropower generation, and recreational activities. They play a crucial role in water resource management and are integral to many modern water infrastructure systems.

Types of Reservoirs

1. Natural Reservoirs

- **Lakes:** Natural depressions that have accumulated water over time. Examples include Lake Superior and Lake Victoria.

2. Artificial Reservoirs

- **Impoundments:** Created by constructing a dam across a river or stream to hold back and store water. These are the most common type of artificial reservoirs.
- **Off-Stream Reservoirs:** Built by excavating a site and filling it with water from nearby sources rather than directly from a river.

Purposes of Reservoirs

1. Water Supply

- **Drinking Water:** Reservoirs provide a reliable source of potable water for communities, cities, and towns.
- **Industrial Use:** Provides water for industrial processes and cooling.

2. Flood Control

- **Regulation of Flow:** By storing excess water during heavy rainfall or snowmelt, reservoirs help reduce downstream flooding and manage river flow.

3. Irrigation

- **Agricultural Use:** Reservoirs store water for irrigation purposes, ensuring a stable supply for crops and reducing dependency on rainfall.

4. Hydropower Generation

- **Energy Production:** Reservoirs facilitate the generation of hydroelectric power by releasing stored water to drive turbines.

5. Recreation

- **Leisure Activities:** Reservoirs provide opportunities for recreational activities such as boating, fishing, swimming, and camping.

6. Environmental Benefits

- **Habitat Creation:** Reservoirs can create new habitats for wildlife and support biodiversity.

Components of a Reservoir

1. Dam

- **Structure:** A barrier built across a river or stream to impound water and create a reservoir. Dams can be made from earth, concrete, rock, or a combination of materials.
- **Types:** Includes gravity dams, arch dams, buttress dams, and earthfill dams, each designed based on the site conditions and engineering requirements.

2. Spillway

CHAPTER 5

Groundwater and Management

Mr.D.Jeyakumar

Groundwater refers to water located beneath the Earth's surface in soil pore spaces and rock formations. It plays a crucial role in the hydrological cycle, serving as a major source of fresh water for drinking, irrigation, and industrial uses. Effective management of groundwater is essential for sustaining water supplies, supporting ecosystems, and mitigating the impacts of overuse and contamination.

Key Concepts of Groundwater

1. Aquifers

- **Definition:** Underground layers of water-bearing rock or sediment that can store and transmit groundwater. Aquifers are classified into:
 - **Confined Aquifers:** Surrounded by impermeable layers, leading to pressure that can cause water to rise in wells.
 - **Unconfined Aquifers:** Directly exposed to the surface and recharged by rainfall or surface water.
- **Types:**
 - **Sandstone Aquifers:** Formed in porous sandstone formations.
 - **Limestone Aquifers:** Created in carbonate rock formations with significant porosity and permeability.
 - **Gravel Aquifers:** Composed of loose gravel and sand, often with high permeability.

2. Groundwater Flow

- **Hydraulic Gradient:** The slope of the water table or potentiometric surface, driving groundwater flow from areas of high pressure to low pressure.
- **Flow Pathways:** Groundwater moves through aquifers along flow paths that can be influenced by geological formations, recharge areas, and discharge points.

3. Recharge and Discharge

- **Recharge:** The process by which groundwater is replenished from surface water sources, such as rainfall, rivers, or artificial recharge techniques.
- **Discharge:** The process by which groundwater exits the aquifer system, occurring through springs, wells, or natural outflows into rivers and lakes.

4. Water Table

- **Definition:** The upper surface of the groundwater where the pressure is equal to atmospheric pressure. It separates the saturated zone (below) from the unsaturated zone (above).

Groundwater Management

1. Sustainable Use

- **Monitoring and Assessment:** Regular monitoring of groundwater levels, quality, and usage to ensure sustainable management. This includes assessing recharge rates, extraction rates, and potential impacts on aquifer health.
- **Water Conservation:** Implementing practices to reduce water use and increase efficiency, such as efficient irrigation techniques and water-saving technologies.

2. Contamination Control

CHAPTER 6

Management of water resources

Mrs.M.Karpagam

Management of water resources involves planning, developing, distributing, and managing the use of water resources in a sustainable manner. Effective water resource management is essential for ensuring the availability of water for various needs while protecting ecosystems and maintaining water quality. Here's a comprehensive overview of water resource management:

Key Objectives

1. **Sustainability:** Ensuring that water resources are available for future generations by managing them in a way that meets current needs without compromising the ability of future generations to meet their needs.
2. **Equity:** Providing fair and equitable access to water for all users, including marginalized and disadvantaged communities.
3. **Efficiency:** Using water resources efficiently to minimize waste and maximize benefits.
4. **Protection:** Safeguarding water quality and aquatic ecosystems from pollution and degradation.

Components of Water Resource Management

A. Water Allocation

- **Water Rights:** Establishing legal frameworks for the allocation of water rights among different users, including agricultural, industrial, and domestic users.
- **Priority Uses:** Setting priorities for water use, particularly during shortages, to ensure essential needs are met (e.g., drinking water and sanitation).

B. Water Quality Management

- **Monitoring and Assessment:** Regularly testing and assessing water quality to detect and address pollution sources and maintain safe drinking water standards.
- **Pollution Control:** Implementing measures to prevent and reduce water pollution from industrial discharges, agricultural runoff, and other sources.

C. Infrastructure Development

- **Supply Infrastructure:** Building and maintaining infrastructure for water supply, such as dams, reservoirs, pipelines, and treatment facilities.
- **Distribution Systems:** Designing and operating systems to deliver water efficiently to users, including urban and rural areas.
- **Wastewater Management:** Developing facilities for wastewater treatment and recycling to protect water bodies and reuse resources.

D. Demand Management

- **Water Conservation:** Promoting practices and technologies to reduce water use, such as efficient irrigation methods, water-saving fixtures, and public awareness campaigns.
- **Water Pricing:** Implementing pricing strategies to reflect the true cost of water and encourage efficient use.

E. Integrated Water Resources Management (IWRM)

CHAPTER 7

Groundwater Technology

Mrs.K.Shanthi

Groundwater technology encompasses a range of tools, techniques, and methods used to explore, extract, manage, and protect groundwater resources. These technologies are critical for ensuring efficient and sustainable use of groundwater, addressing challenges related to water scarcity, contamination, and resource management.

Key Areas of Groundwater Technology

1. Exploration and Assessment

1. Geophysical Methods

- **Seismic Refraction:** Uses seismic waves to determine the depth and characteristics of groundwater-bearing layers.
- **Electrical Resistivity:** Measures the resistance of subsurface materials to electric current, helping to identify aquifer boundaries and water quality.
- **Ground-Penetrating Radar (GPR):** Uses radar pulses to image the subsurface and detect variations in soil and rock properties.

2. Hydrogeological Surveys

- **Borehole Logging:** Involves drilling and examining boreholes to assess aquifer properties, water quality, and geological formations.
- **Aquifer Testing:** Includes pumping tests and slug tests to measure aquifer characteristics such as permeability, transmissivity, and storage capacity.

3. Remote Sensing

- **Satellite Imagery:** Provides data on land use, vegetation, and hydrological features that can be used to infer groundwater conditions and changes.
- **Aerial Surveys:** Includes the use of drones and aircraft to gather data on groundwater recharge areas and surface water interactions.

2. Extraction and Utilization

1. Well Construction and Design

- **Types of Wells:** Includes different types of wells such as observation wells, production wells, and monitoring wells, each designed for specific purposes.
- **Drilling Technologies:** Utilizes various drilling techniques, including rotary drilling, air drilling, and auger drilling, to access groundwater.

2. Pumping Technologies

- **Submersible Pumps:** Installed within the well to lift water from the aquifer to the surface.
- **Centrifugal Pumps:** Used for larger-scale groundwater extraction, often in agricultural or industrial applications.

3. Water Treatment

- **Filtration Systems:** Includes sand filters, activated carbon filters, and membrane filtration to remove impurities from groundwater.
- **Disinfection:** Uses methods such as chlorination, ultraviolet (UV) light, and ozone treatment to ensure safe drinking water quality.

3. Monitoring and Management

1. Groundwater Monitoring Systems

- **Monitoring Wells:** Installed to measure water levels, quality, and changes in groundwater over time.

CHAPTER 8

Storm water management

Mrs.T.Viduthalai

Stormwater management refers to the planning, design, and implementation of practices and infrastructure to manage the runoff from precipitation events such as rain and snow. Effective stormwater management is essential for preventing flooding, reducing water pollution, and protecting water quality and ecosystems.

Key Objectives of Stormwater Management

1. **Flood Prevention and Control:** Managing the volume and rate of stormwater runoff to reduce the risk of flooding in urban and rural areas.
2. **Water Quality Protection:** Treating stormwater to remove pollutants and prevent them from entering water bodies.
3. **Erosion Control:** Preventing soil erosion and sedimentation caused by stormwater runoff.
4. **Sustainable Development:** Integrating stormwater management into land use planning and development to promote environmental sustainability.

Components of Stormwater Management

1. Stormwater Management Practices

1. Structural Controls

- **Retention Basins:** Ponds or basins designed to capture and store stormwater, allowing it to slowly infiltrate or evaporate.
- **Detention Basins:** Temporary storage areas that hold stormwater and release it at a controlled rate to prevent downstream flooding.
- **Green Infrastructure:** Utilizes natural systems to manage stormwater, including:
 - **Green Roofs:** Vegetative layers on roofs that absorb and slow down stormwater runoff.
 - **Permeable Pavements:** Pavement materials that allow water to pass through and infiltrate into the ground.
 - **Rain Gardens:** Shallow, vegetated depressions designed to capture and treat runoff from impervious surfaces.

2. Non-Structural Controls

- **Land Use Planning:** Integrating stormwater management considerations into land use and development planning to reduce runoff and protect natural systems.
- **Best Management Practices (BMPs):** Practices such as minimizing impervious surfaces, maintaining vegetated areas, and incorporating stormwater management into site design.

2. Stormwater Infrastructure

1. Drainage Systems

- **Storm Drains:** Pipes and channels that collect and convey stormwater runoff from streets and other surfaces to drainage facilities or water bodies.
- **Catch Basins:** Grated structures that capture debris and sediment from stormwater before it enters the drainage system.

2. Water Quality Improvement

- **Oil and Grit Separators:** Devices that remove oil, grease, and sediment from stormwater runoff before it reaches water bodies.
- **Swales:** Shallow, vegetated channels that slow down and filter stormwater runoff.

3. Flood Control Infrastructure

CHAPTER 9

Water quality

Mr. D.AmalColins

Water quality refers to the physical, chemical, and biological characteristics of water, which determine its suitability for various uses and its impact on health and the environment. Ensuring high water quality is essential for public health, ecological balance, and sustainable development.

Key Aspects of Water Quality

1. Physical Characteristics

- **Turbidity:** Cloudiness or haziness caused by large numbers of individual particles, which can affect the aesthetic quality and treatment of water.
- **Color:** Can be influenced by natural substances like tannins and humic acids, or by contaminants such as dyes or metals.
- **Temperature:** Affects the solubility and reaction rates of chemicals and biological processes. Water temperature can influence the growth of microorganisms and aquatic life.
- **Odor and Taste:** Odors and tastes in water can indicate the presence of contaminants or pollutants.

2. Chemical Characteristics

- **pH:** Measures the acidity or alkalinity of water. Most natural waters have a pH between 6.5 and 8.5. Extreme pH levels can affect aquatic life and the effectiveness of treatment processes.
- **Dissolved Oxygen (DO):** The amount of oxygen available in water, crucial for the survival of aquatic organisms. Low DO levels can lead to hypoxia and affect aquatic ecosystems.
- **Nutrients:** Includes compounds like nitrogen (nitrate, nitrite, ammonia) and phosphorus. Excessive nutrients can lead to eutrophication, causing algal blooms and oxygen depletion.
- **Toxic Elements:** Includes heavy metals (e.g., lead, mercury, arsenic) and other harmful substances. These can have adverse health effects and environmental impacts.

3. Biological Characteristics

- **Microorganisms:** Includes bacteria, viruses, protozoa, and algae. Pathogenic microorganisms can cause waterborne diseases. Common indicators of microbial contamination include:
 - **Coliform Bacteria:** Used as an indicator of potential contamination by fecal matter.
 - **E. coli:** Specific type of coliform bacteria indicating fecal contamination and potential presence of pathogens.
- **Biological Oxygen Demand (BOD):** Measures the amount of oxygen required by microorganisms to decompose organic matter in water. High BOD can indicate pollution and low water quality.

Water Quality Standards and Guidelines

1. Drinking Water Standards

- **Regulatory Limits:** Set by agencies such as the Environmental Protection Agency (EPA) in the U.S., or the World Health Organization (WHO). These standards include limits on contaminants such as microorganisms, chemicals, and radionuclides.
- **Treatment Requirements:** Specifications for treatment processes to ensure safe drinking water, including filtration, disinfection, and chemical treatment.

2. Recreational Water Quality

- **Health Guidelines:** Standards for water used in recreational activities such as swimming, including limits on microbial contamination and chemical pollutants.

CHAPTER 10

Sustainable water supply systems

Mrs.R.Devi

Sustainable water supply systems are designed to provide reliable, safe, and equitable access to water while minimizing environmental impact and ensuring the long-term availability of water resources. The goal is to balance the needs of current users with the ability of future generations to meet their water needs, all while protecting ecosystems and reducing waste.

Key Principles of Sustainable Water Supply Systems

1. **Resource Efficiency:** Using water resources efficiently to reduce waste and ensure the maximum benefit from available water.
2. **Equitable Access:** Providing fair and equitable access to water for all users, including marginalized and underserved communities.
3. **Environmental Protection:** Minimizing the impact of water supply systems on ecosystems and natural water sources.
4. **Resilience:** Designing systems that can adapt to changes and withstand challenges such as climate change, population growth, and extreme weather events.

Components of Sustainable Water Supply Systems

1. Water Resource Management

1. **Integrated Water Resources Management (IWRM)**
 - **Holistic Approach:** Coordinating the management of water resources across sectors (e.g., agriculture, industry, domestic use) and scales (e.g., local, regional, national).
 - **Stakeholder Participation:** Engaging communities, governments, and other stakeholders in decision-making processes to address water management challenges.
2. **Water Conservation**
 - **Demand Management:** Implementing practices and policies to reduce water use and promote efficient water use, such as water-saving technologies and behavioral changes.
 - **Water Recycling and Reuse:** Treating and reusing wastewater for non-potable purposes (e.g., irrigation, industrial processes) to reduce the demand on freshwater resources.
3. **Sustainable Water Supply Planning**
 - **Long-Term Planning:** Developing water supply plans that consider future demand, climate change impacts, and potential resource constraints.
 - **Climate Adaptation:** Incorporating strategies to adapt to changing climate conditions, such as altering water supply sources or improving infrastructure resilience.

2. Water Infrastructure

1. **Efficient Distribution Systems**
 - **Leak Detection and Repair:** Implementing technologies and practices to detect and fix leaks in water distribution systems, reducing water loss.
 - **Smart Water Grids:** Using sensors and data analytics to optimize water distribution, monitor system performance, and improve efficiency.
2. **Sustainable Source Development**
 - **Alternative Water Sources:** Exploring and developing alternative sources of water, such as rainwater harvesting, desalination, and groundwater recharge.
 - **Protecting Source Water:** Ensuring the protection of natural water sources from contamination and over-extraction through conservation measures and land use planning.
3. **Green Infrastructure**



PREFABRICATED STRUCTURES

EDITED BY



A.BELCIYA MARY

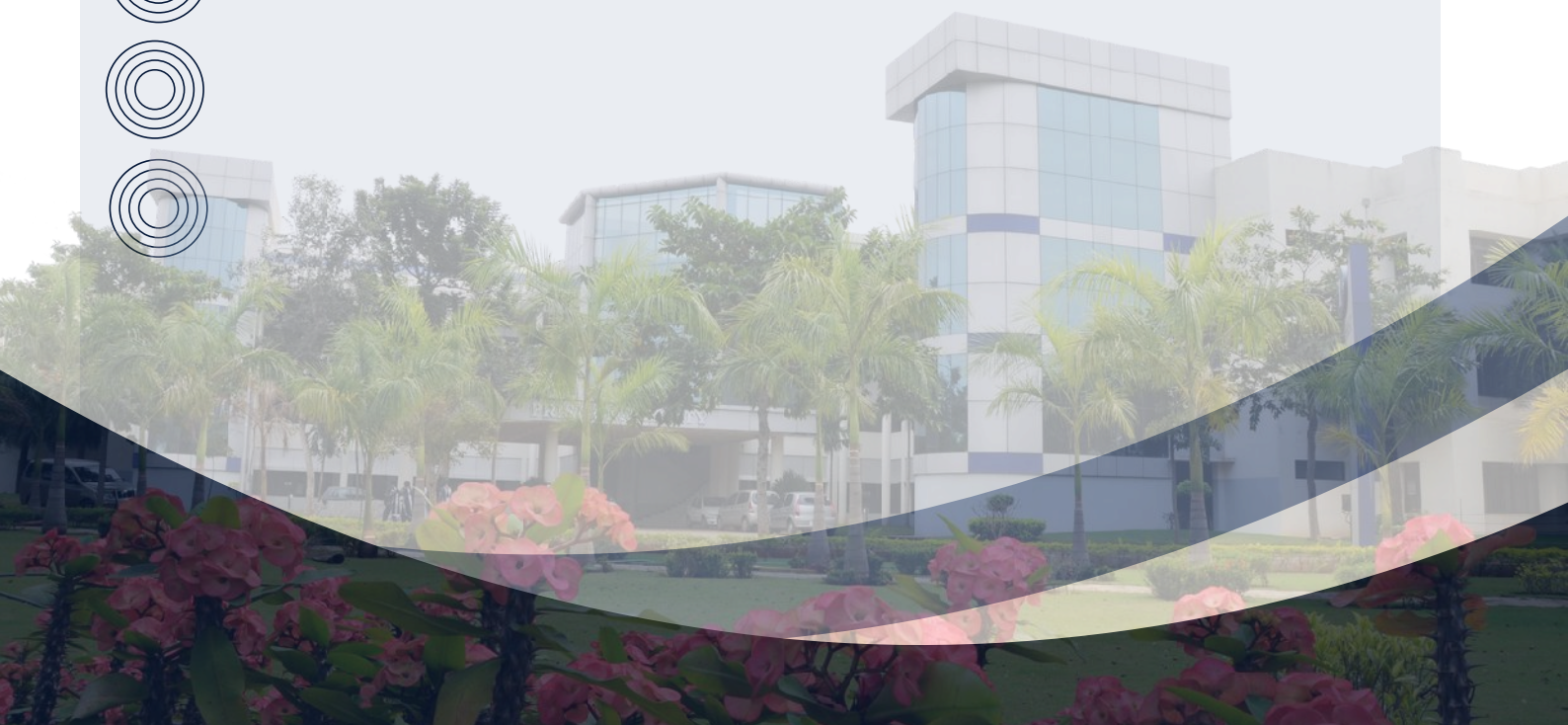

978-93-6255-396-6

Prefabricated Structures
Copyright © 2023 by Mrs.A.Belciya Mary

All rights reserved. No part of this book may be reproduced or transmitted in any form or by any means without written permission from the author.

ISBN: 978-93-6255-396-6

Publisher: PonnaiyahRamajayam Institute of Science and Technology (PRIST)

TABLE OF CONTENTS

| | |
|---|-------------|
| INTRODUCTION | -05 |
| CHAPTER 1 - Prefabricated Components Mrs.A.Belciya Mary | -14 |
| CHAPTER 2 -Design Principle Mrs.T.Vidudhalai | -28 |
| CHAPTER 3 - Joints and Connections in Structural Members Mr.D Jeyakumar | -43 |
| CHAPTER 4 - Design for Abnormal Loads Mr.D.AmalColins | -65 |
| CHAPTER 5 -Prefabrication Mrs.R Devi | -78 |
| CHAPTER 6-Modular construction Mr.DJeyakumar | -85 |
| CHAPTER 7 -Insulated precast concrete panels Mrs.A.Belciya Mary | - 103 |
| CHAPTER 8—Advantages of prefabricated structures Mr.S.Ramakrishnan | -121 |
| CHAPTER 9—Disadvantages of prefabricated structures Mr.D.AmalColins | -145 |
| CHAPTER 10-Off-site fabrication Mrs.R Devi | -160 |
| REFERENCES | -180 |

CHAPTER 1

Prefabricated Components

Mrs.A.Belciya Mary

Prefabricated components refer to building elements that are manufactured off-site in a controlled environment before being transported and assembled at the construction site. This approach offers several advantages and can be applied across various construction projects, from residential buildings to large infrastructure developments.

1. **Time Efficiency**
 - **Reduced Construction Time:** On-site construction time is significantly decreased, as components are prepared simultaneously with site work.
 - **Faster Assembly:** Pre-manufactured parts can be quickly assembled on-site.
2. **Cost Savings**
 - **Lower Labor Costs:** Less on-site labor is needed, reducing labor costs and mitigating scheduling conflicts.
 - **Bulk Purchasing:** Components can be produced in bulk, lowering material costs.
3. **Quality Control**
 - **Controlled Environment:** Components are made in a factory setting, allowing for better quality control and consistent standards.
 - **Reduced Waste:** Manufacturing processes are often more efficient, leading to less material waste.
4. **Design Flexibility**
 - **Customization:** Prefabricated components can be tailored to specific design requirements and can easily accommodate changes.
 - **Modular Systems:** Components can be designed as modular systems, facilitating future expansions or modifications.
5. **Sustainability**
 - **Reduced Site Impact:** Less disturbance to the construction site leads to less environmental impact.
 - **Energy Efficiency:** Prefabrication can include energy-efficient materials and designs, improving the overall sustainability of the building.

Common Types of Prefabricated Components

1. **Wall Panels**
 - Pre-assembled wall sections that include framing, insulation, and exterior finishes.
2. **Floor Systems**
 - Precast concrete slabs or modular flooring systems that can be quickly installed.
3. **Roof Trusses**
 - Engineered trusses that are fabricated off-site and easily transported.
4. **Bathroom Pods**
 - Fully fitted bathroom units that are manufactured and delivered for quick installation.
5. **Structural Components**
 - Beams, columns, and other structural elements made from materials like steel or concrete.

Applications

- **Residential Construction:** Homes built with prefabricated modules for faster occupancy.
- **Commercial Buildings:** Offices and retail spaces utilizing pre-manufactured walls and floors.
- **Infrastructure Projects:** Bridges, tunnels, and other infrastructure utilizing precast concrete components.

CHAPTER 2

Design Principle

Mrs.T.Vidudhalai

Design principles are fundamental guidelines that inform the creation of effective and aesthetically pleasing designs across various fields, including graphic design, architecture, product design, and more. Here are some key design principles:

1. Balance

- **Symmetrical Balance:** Equal visual weight on both sides.
- **Asymmetrical Balance:** Different elements balanced in visual weight for a dynamic feel.

2. Contrast

- Use differing elements (e.g., color, size, shape) to create visual interest and highlight important aspects.

3. Emphasis

- Focus on a central element to draw attention, often through contrast, placement, or size.

4. Movement

- Guide the viewer's eye through the design, using lines, shapes, or directional elements.

5. Pattern

- Repeating elements can create rhythm and unity, adding texture and interest.

6. Repetition

- Consistent use of colors, shapes, or styles helps create cohesion and reinforces brand identity.

7. Alignment

- Organizing elements to create a visual connection and structure, enhancing readability and clarity.

8. Proximity

- Grouping related items together helps organize information and improves the overall layout.

9. White Space (Negative Space)

- The use of empty space around elements enhances clarity and focus, preventing clutter.

10. Hierarchy

CHAPTER 3

Joints and Connections in Structural Members

Mr.D.Jeyakumar

Joints and connections in structural members are critical for ensuring the integrity, stability, and functionality of a structure. They determine how different components of a structure interact and bear loads. Here's an overview of common types, their purposes, and considerations:

Types of Joints and Connections

1. Bolted Connections

- **Description:** Use bolts to connect two or more structural members.
- **Applications:** Common in steel structures, allowing for easy assembly and disassembly.
- **Considerations:** Requires careful design to ensure shear and tensile strength.

2. Welded Connections

- **Description:** Metal pieces are fused together using heat.
- **Applications:** Common in steel and aluminum structures, providing strong, permanent connections.
- **Considerations:** Requires skilled labor and proper welding techniques to prevent defects.

3. Riveted Connections

- **Description:** Uses rivets to join metal pieces, historically popular in bridges and older structures.
- **Applications:** Still used in some applications, but largely replaced by welding and bolting.
- **Considerations:** Requires precise fitting and can be labor-intensive.

4. Pinned Connections

- **Description:** Utilize pins to connect members, allowing rotation.
- **Applications:** Common in trusses and bridges, providing flexibility and movement.
- **Considerations:** Must be designed to handle shear forces and accommodate movement.

5. Moment Connections

- **Description:** Designed to transfer bending moments between members, often through welding or bolting.
- **Applications:** Used in frames where stability is crucial, such as in buildings.
- **Considerations:** Requires careful design to manage forces and moments effectively.

6. Shear Connections

- **Description:** Designed primarily to transfer shear forces between members.
- **Applications:** Often used in beam-to-column connections in steel structures.
- **Considerations:** Should be detailed to accommodate potential slip and shear forces.

7. Composite Connections

- **Description:** Involves combining different materials (e.g., steel and concrete) to leverage their strengths.
- **Applications:** Common in modern construction, particularly in composite beams and slabs.
- **Considerations:** Must account for differing material properties and behaviors under load.

Design Considerations

1. Load Types

- Understand the types of loads (tension, compression, shear, moment) the connection will experience.

2. Material Properties

- Consider the strength, ductility, and behavior of materials under load and environmental conditions. **Fatigue and Durability** Design connections to withstand repeated loading and environmental factors that may lead to deterioration.

CHAPTER 4

Design for Abnormal Loads

Mr. D.AmalColins

Designing for abnormal loads involves considering unusual or extreme conditions that a structure might encounter beyond typical operational loads. These can include seismic events, wind loads, snow accumulation, blasts, impacts, and other unforeseen stresses. Here's an overview of how to approach this type of design:

Key Considerations

1. Load Identification

- **Seismic Loads:** Evaluate potential earthquake forces based on geographic location.
- **Wind Loads:** Consider extreme wind conditions, including gusts and tornadoes.
- **Snow Loads:** Assess potential snow accumulation based on local climate data.
- **Impact Loads:** Account for accidental impacts from vehicles, machinery, or debris.
- **Blast Loads:** Evaluate potential explosion forces, especially for critical infrastructure.

2. Regulatory Standards

- Follow relevant codes and standards, such as ASCE 7 (American Society of Civil Engineers) for load requirements or specific local regulations that address abnormal loading conditions.

3. Structural Analysis

- Use advanced analysis methods to simulate abnormal loading scenarios, such as finite element analysis (FEA) or dynamic analysis for seismic and wind loads.
- Consider both static and dynamic responses of structures.

4. Material Selection

- Choose materials with appropriate strength and ductility to withstand abnormal loads.
- Consider using high-performance materials or reinforcing existing materials to enhance resilience.

5. Safety Factors

- Apply increased safety factors for abnormal load scenarios, recognizing the uncertainty and potential for greater stress on structural components.

6. Redundancy and Robustness

- Design structures with redundancy to ensure that if one component fails, the load can be redistributed to other components.
- Consider the overall robustness of the design to withstand unexpected events without catastrophic failure.

7. Connections and Joints

- Ensure connections are designed to handle unexpected forces and maintain structural integrity under abnormal loads.
- Use moment and shear connections as needed to transfer loads effectively.

8. Maintenance and Inspection

- Plan for regular inspections and maintenance to identify potential weaknesses or damage that could be exacerbated by abnormal loads.

Specific Design Strategies

1. Ductility and Energy Dissipation

- Incorporate features that allow structures to deform without collapsing, particularly important for seismic design.

2. Stiffening Elements

Add bracing, shear walls, or other stiffening elements to enhance the structure's ability to resist lateral loads.

CHAPTER 5

Prefabrication

Mrs. R.Devi

Prefabrication is a construction method where components of a building are manufactured in a factory and then transported to the construction site for assembly. This approach can significantly speed up the building process, reduce waste, and often improve quality by using controlled manufacturing environments. Prefabricated elements can include walls, roofs, floors, and even entire modular units.

Benefits of Prefabrication:

1. **Time Efficiency:** Construction timelines are often shorter since many elements can be produced simultaneously with site preparation.
2. **Cost-Effectiveness:** Reduced labor costs and material waste can lead to lower overall project expenses.
3. **Quality Control:** Factory conditions allow for better monitoring and consistency in the manufacturing process.
4. **Less Site Disruption:** With fewer activities occurring on-site, there's less noise, dust, and disruption to the surrounding area.
5. **Sustainability:** Prefabrication can lead to less waste and energy consumption compared to traditional construction methods.

Types of Prefabrication:

1. **Modular Construction:** Entire sections of buildings are pre-constructed and then assembled on-site.
2. **Panelized Systems:** Wall panels, roof trusses, and other structural elements are pre-made and then put together on-site.
3. **3D Printing:** Innovative technology allowing for the creation of building components or even entire structures layer by layer.

Challenges:

1. **Transport Costs:** Moving large prefabricated sections can be expensive and logistically complex.
2. **Design Limitations:** There may be restrictions in customization due to the manufacturing process.
3. **Site-Specific Issues:** Variability in site conditions may complicate the assembly of prefabricated elements.

Overall, prefabrication is a growing trend in the construction industry, driven by the need for efficiency, sustainability, and quality.

CHAPTER 6

Modular construction

Mr. D Jeyakumar

Modular construction is a method where buildings are created from pre-fabricated sections, or modules, that are manufactured off-site and then transported to the construction site for assembly. This approach offers numerous advantages and is increasingly popular in various sectors, including residential, commercial, and industrial construction.

Key Features of Modular Construction:

1. **Pre-Fabricated Modules:** Each module can include walls, floors, ceilings, and sometimes even plumbing and electrical systems. These are built in a controlled factory environment.
2. **On-Site Assembly:** Once the modules are delivered to the site, they are assembled into the final structure, often in a fraction of the time required for traditional construction methods.
3. **Design Flexibility:** Modular buildings can be customized to meet specific needs, allowing for various layouts and sizes.

Benefits of Modular Construction:

1. **Time Savings:** Construction timelines are significantly reduced since site work and module production can occur simultaneously.
2. **Cost Efficiency:** Lower labor costs and reduced material waste can make modular construction more economical.
3. **Quality Control:** Factory conditions provide better oversight and consistency in the building process.
4. **Reduced Site Disruption:** With less construction activity happening on-site, there's less noise and disruption for the surrounding community.
5. **Sustainability:** Modular construction can lead to less waste and energy consumption, making it a more environmentally friendly option.

Applications:

- **Residential Buildings:** Homes and apartment complexes can be built quickly and efficiently.
- **Commercial Spaces:** Offices, schools, and retail spaces can benefit from modular construction.
- **Healthcare Facilities:** Hospitals and clinics can be expanded or constructed rapidly to meet urgent needs.

Challenges:

1. **Transport Logistics:** Moving large modules can be complex and costly, especially over long distances.
2. **Site Limitations:** The suitability of a site for modular construction can be impacted by access for delivery and assembly.
3. **Building Codes:** Compliance with local building regulations can be more complicated when modules are manufactured in different regions.

Modular construction represents a significant shift in the building industry, combining efficiency with quality and sustainability. As technology advances and the demand for faster, more economical building solutions grows, modular construction is likely to continue expanding in popularity.

CHAPTER 7

Insulated precast concrete panels

Mrs.A.Belciya Mary

Insulated precast concrete panels are a building material that combines the strength and durability of concrete with thermal insulation properties. These panels are manufactured in a factory setting and can be used for walls, roofs, and floors in various construction applications. Here's a closer look at their features, benefits, and applications.

Key Features:

1. **Insulation Core:** These panels typically consist of a layer of insulation sandwiched between two layers of concrete. Common insulation materials include polystyrene, polyurethane, or mineral wool.
2. **Manufacturing:** Panels are produced in controlled environments, ensuring high quality and consistency. They can be designed to specific dimensions and requirements.
3. **Modular Design:** Insulated precast panels can be custom-designed for various architectural needs, allowing for flexibility in building design.

Benefits:

1. **Energy Efficiency:** The insulation core helps reduce heat loss in winter and heat gain in summer, leading to lower energy costs for heating and cooling.
2. **Speed of Construction:** Panels can be quickly assembled on-site, significantly reducing construction time compared to traditional methods.
3. **Durability:** Concrete is resistant to weather, fire, and pests, making these panels long-lasting and low-maintenance.
4. **Acoustic Performance:** The mass of concrete provides excellent sound insulation, making these panels suitable for residential and commercial applications.
5. **Design Flexibility:** Panels can be produced in various sizes, shapes, and finishes, allowing for creative architectural designs.

Applications:

- **Commercial Buildings:** Often used in the construction of offices, retail spaces, and warehouses.
- **Residential Projects:** Increasingly popular for single-family homes and multi-family units.
- **Industrial Facilities:** Ideal for manufacturing plants, storage facilities, and distribution centers.
- **Institutional Buildings:** Used in schools, hospitals, and government buildings for their energy efficiency and durability.

Challenges:

1. **Transport and Handling:** The size and weight of precast panels can make transportation and installation challenging, requiring specialized equipment.
2. **Initial Costs:** While they can save money in the long run, the upfront costs for materials and transportation can be higher compared to traditional methods.
3. **Site Preparation:** Proper foundation and site preparation are crucial for the successful installation of precast panels.

CHAPTER 8

Advantages of prefabricated structures

Mr.S.Ramakrishnan

Prefabricated structures offer a variety of advantages that make them an attractive option for many construction projects. Here are some key benefits:

1. Speed of Construction

- **Reduced Timeline:** Many components are manufactured simultaneously with site preparation, allowing for quicker assembly.
- **Fast Turnaround:** Projects can be completed in a fraction of the time compared to traditional construction methods.

2. Cost Efficiency

- **Lower Labor Costs:** Streamlined processes in a factory setting can reduce the number of labor hours needed on-site.
- **Less Material Waste:** Factory production minimizes excess materials, leading to cost savings.

3. Quality Control

- **Consistent Standards:** Controlled manufacturing environments ensure higher quality and uniformity of components.
- **Fewer Defects:** Enhanced oversight during production leads to fewer issues compared to on-site construction.

4. Design Flexibility

- **Customization:** Prefabricated components can be designed to meet specific architectural and functional requirements.
- **Modularity:** Structures can be easily expanded or modified with additional modules.

5. Reduced Site Disruption

- **Less Noise and Traffic:** With fewer activities occurring on-site, there's reduced disruption for neighboring areas.
- **Shorter Construction Duration:** The quicker assembly means less prolonged construction impacts.

6. Sustainability

- **Lower Carbon Footprint:** Efficient use of materials and reduced waste contribute to a smaller environmental impact.
- **Energy Efficiency:** Prefabricated structures can incorporate advanced insulation and energy-efficient systems.

7. Improved Safety

- **Controlled Environment:** Factory production reduces on-site hazards and the risks associated with weather delays.
- **Less On-Site Work:** Fewer workers on-site mean lower chances of accidents during construction.

CHAPTER 9

Disadvantages of prefabricated structures

Mr.D.AmalColins

A strategic and systematic approach involves clearly defining goals and objectives, analyzing the current while prefabricated structures offer many advantages, there are also several disadvantages to consider. Here are some key challenges associated with prefabrication:

1. Transport and Logistics

- **Transportation Costs:** Moving large prefabricated components to the construction site can be expensive, especially over long distances.
- **Handling and Installation:** Requires specialized equipment and skilled labor for safe transport and assembly, which can complicate logistics.

2. Site Limitations

- **Foundation Requirements:** Precise site preparation is needed to ensure the foundation is compatible with prefabricated components, which can be time-consuming and costly.
- **Accessibility:** Difficult access to the site can hinder the delivery and assembly of large panels or modules.

3. Design Constraints

- **Customization Limits:** While many prefabricated systems allow for some customization, there may be restrictions based on manufacturing capabilities.
- **Standardization:** The need for standard sizes and shapes can limit creative architectural design compared to traditional methods.

4. Initial Costs

- **Higher Upfront Investment:** The cost of prefabricated components and transportation can be higher than traditional building materials initially.
- **Potential for Increased Costs:** Custom designs or modifications can lead to unexpected expenses.

5. Building Codes and Regulations

- **Compliance Challenges:** Ensuring that prefabricated components meet local building codes can be complicated, especially if manufactured in different regions.
- **Zoning Restrictions:** Local regulations may affect the use of prefabricated structures, limiting their application in certain areas.

6. Quality Variability

- **Manufacturer Dependency:** The quality of prefabricated components can vary significantly between manufacturers, affecting overall project quality.
- **Potential for Defects:** Although quality control is generally better, defects can still occur during manufacturing or transport.

7. Limited Control Over Construction

- **Less On-Site Supervision:** With much of the work happening off-site, there may be less oversight and direct control during the construction process.

CHAPTER 10

Off-site fabrication

Mrs. R.Devi

Off-site fabrication refers to the process of manufacturing building components in a controlled environment away from the final construction site. This approach encompasses various methods, including prefabrication, modular construction, and panelization, and has become increasingly popular in modern construction due to its numerous advantages.

Key Features of Off-Site Fabrication:

1. **Controlled Environment:** Components are produced in a factory setting, minimizing the impact of weather and site conditions.
2. **Standardization:** Many off-site fabrication processes involve standardized components, which can streamline production and assembly.
3. **Integration of Systems:** Off-site fabrication allows for the integration of mechanical, electrical, and plumbing systems into the components before they arrive on-site.

Advantages:

1. **Speed of Construction:** Parallel processing—manufacturing while site work is underway—can significantly reduce overall project timelines.
2. **Cost Savings:** Reduced labor costs and minimized material waste can lead to lower overall expenses.
3. **Quality Assurance:** Factory conditions provide better quality control, reducing defects and enhancing consistency.
4. **Safety:** Off-site fabrication reduces on-site labor, lowering the risk of accidents and injuries.
5. **Sustainability:** Efficient use of materials and energy in a factory setting can contribute to more sustainable construction practices.
6. **Flexibility and Customization:** While many components are standardized, there is also the potential for customization to meet specific design needs.

Applications:

- **Residential Buildings:** Homes and multi-family units can be built using off-site fabricated components.
- **Commercial Spaces:** Offices, schools, and retail spaces benefit from quicker construction timelines and lower costs.
- **Industrial Facilities:** Factories and warehouses often utilize off-site fabrication for speed and efficiency.

Challenges:

1. **Transportation Logistics:** Moving large components from the factory to the site can be complex and costly.
2. **Site Preparation:** Proper foundation and site readiness are crucial for successful installation of fabricated components.
3. **Design Limitations:** There may be constraints on customization and architectural flexibility compared to traditional construction methods.
4. **Initial Costs:** While often cost-effective in the long run, initial investments for off-site fabrication can be higher.

PROJECT PLANNING AND CONTROL

Edited by

DR T J JAYASHOLAN



978-93-6255-158-0

Project Planning and Control

Copyright © 2023 by DR. T. J. JAYASHOLAN

All rights reserved. No part of this book may be reproduced or transmitted in any form or by any means without written permission from the author.

ISBN: 978-93-6255-158-0

Publisher: Ponnaiyah Ramajayam Institute of Science and Technology (PRIST)

TABLE OF CONTENTS

| | |
|---|------------|
| CHAPTER-I..... | 1 |
| Introduction to planning Dr. M. Balamurugan | |
| CHAPTER –II..... | 12 |
| Steps for project planning Dr T J Jayasholan | |
| CHAPTER –III..... | 30 |
| Introduction to project management Dr. S. Venkatesh | |
| CHAPTER –IV..... | 41 |
| Project lifecycle Dr K G Selvan | |
| CHAPTER -V | 56 |
| Classification of project management Dr. S. Venkatesh | |
| CHAPTER -VI | 62 |
| Cost Schedule Integration and Productivity Analysis K.Sasikumar | |
| CHAPTER –VII..... | 73 |
| Advanced Scheduling Techniques – Linear Scheduling Dr K G Selvan | |
| CHAPTER -VIII | 83 |
| Change Management Dr T J Jayasholan | |
| CHAPTER -IX | 98 |
| Network Modeling and Analysis K. Sasikumar | |
| CHAPTER –X..... | 110 |
| Focuses on the development of financial and operational plans K. Sasikumar | |
| REFERENCES | 120 |

CHAPTER -I
Introduction to planning
Dr. M. Balamurugan, Department of Management,
Ponnaiyah Ramajayam Institute of Science and Technology(PRIST)

Meaning of planning

Planning is the most basic of all managerial functions which involves establishing goals, setting out objectives and defining the methods by which these goals and objectives are to be attained. It is, therefore, a rational approach to achieving pre-selected objectives.

Importance of Planning

The importance of planning as the major constituent in the management process is universally accepted. Planning not only brings stability and certainty to business, it also brings in a unified sense of direction and purpose for the achievement of certain well-defined objectives.

The basic reasons supporting systematic planning by managers are –

- **Sense of Direction** – Planning provides a unity of purpose. It brings together all resources towards achieving common goals. Without plans and goals, organizations will respond to everyday events in an ad-hoc manner without considering long-term possibilities.
- **Resource Paucity** – Resource crunch is a major challenge for organizations today. Managements are confronted with the task of optimizing outputs with limited human, material, and financial resources through intelligent planning; otherwise, wasteful inefficiencies would lead to higher prices and severe shortages.
- **Uncertainty** – Uncertainty is a major challenge even to the most intelligent planner. Organizations continually face micro and macro-economic uncertainty in the course of accomplishing their tasks. Planning helps managers anticipate such changes and meet these challenges.

Besides the above, there are several practical reasons for formulating plans.

- To focus organizational activity on a set of consciously created objectives.
- To provide a systematic guide for future activities.
- To increase organizational outcome through efficient operation.
- To encourage systematic thinking. Planning facilitates effective delegation of authority, removes communication gaps, and thereby raises overall efficiency.

CHAPTER -II
Steps for project planning
Dr T J Jayasholan, Department of Management,
Ponnaiyah Ramajayam Institute of Science and Technology(PRIST)

1. Determine the project goals and objectives

The first step in the project planning phase is to define the goals and objectives of your project. Project goals and objectives help you decide if the project should be prioritized (or even undertaken—essentially you need to use a proof of concept).

2. Determine the project scope

Stakeholders often request extra tasks or significant changes in direction (sometimes several of them) during a project that could derail it. Your project scope protects you from unrealistic expectations, conflicting interests, and unattainable demands as the project progresses.

3. Build your work breakdown structure (WBS)

At this stage, start determining which tasks, subtasks, and deliverables must be carried out to complete the project. You can do this by referring to your scope and creating a work breakdown structure—a structured decomposition of tasks needed to complete a project. A WBS is often accompanied by a resource breakdown structure (RBS), where both represent what activities the project team needs to complete and what resources are necessary for each work package.

4. Set timelines

Now that you have individual tasks created, you can set timelines for each activity. Project timelines help you estimate the completion date and keep things on track. Timelines are usually plotted on a Gantt chart or in a resource management tool like Float.

- Determine the skills/criteria you need
- Confirm future availability of resources
- Identify costs of resources, e.g., hourly rates
- Find out about special requirements

6. Estimate costs

One of the challenges in the project planning process is balancing your budget with your stakeholders' desire to save money. However, if you underestimate costs, you might find yourself without funds in the middle of the project. To approximate the cost of the project, you can use:

Choose your method and establish an initial cost baseline. Make sure to include details about the contact person and processes for releasing the funds. For example, the team lead could approve spending for limited amounts, while larger amounts must be approved by the finance department.

7. Determine risks and constraints

No project exists without risks or constraints. The key to avoiding a project failure is identifying the potential pitfalls and creating an action plan to handle them.

8. Plan out communication

Creating a communication blueprint is essential in developing a project plan. "No matter what role you're playing on a project, if you're not making a strong effort to communicate with your team, you will likely fail," says Harned.

CHAPTER -III
Introduction to project management
Dr. S. Venkatesh, Department of Management,
Ponnaiyah Ramajayam Institute of Science and Technology(PRIST)

Features of project management

A project has a lifecycle, underpinned by a plan, which is the path and sequence through the various activities defined to produce its products. Project management is a controlled implementation of the project plan under the direction of the organisation's senior management.

Traditionally, a successful project is one that has delivered its products or services according to the project plan, meeting overall business objectives. Project success is now seen more and more in terms of delivering projected business benefits or the capability required for benefits delivery within the business.

A properly managed project will usually have:

- senior level sponsorship from within the organisation
- strong leadership, accountability, and governance arrangements
- a dedicated project manager
- a project plan and adequate resources to implement the plan
- clear processes for the management of risks, issues, stakeholders, communications, and benefits
- effective project assurance arrangements
- well defined reporting structures and a clearly understood project scope

Some of the key documents usually associated with a properly managed project are:

- a business case justifying the investment and proposed changes
- a project initiation document setting out the project objectives and the means for achieving them
- a project plan setting out the main products or services and all associated resources and activities
- standards for reporting progress and highlighting issues
- registers for recording risks and issues and managing their escalation
- end project and lessons learned reports
- a post project review report, independent of the project, reporting estimates against eventual outturns including the extent to which projected benefits have been realized.

CHAPTER -IV
Project lifecycle
Dr K G Selvan, Department of Management,
Ponnaiyah Ramajayam Institute of Science and Technology(PRIST)

The Project Lifecycle consists of seven phases intake, initiation, planning, product selection, execution, monitoring & control, and closure. These phases make up the path that takes your project from start to finish.

Intake Life Cycle

Project Intake is a process of reviewing and evaluating a proposed project during the initiation phase. The purpose is to confirm that the project is feasible and aims to address the stated problem. The process is also intended to review the organizational structure of the proposed project to define whether allocated human resources are sufficient and available for doing the project and producing desired deliverables.

Initiation

This process helps in the visualization of what is to be accomplished. This is where the project is formally approved by the sponsor/client, initial scope defined, and stakeholders identified.

Planning

The planning stage is where the project plans are documented, the project deliverables and requirements are defined, and the project schedule is created. It involves creating a set of plans to help guide your team through the implementation and closure phases of the project.

Product Selection

This process refers to the selection, evaluation, and procurement of IT software that will be used and consumed in the project delivery.

Execution - Implementation

This process is also known as the implementation phase, in which the plan designed in the previous phase of the project activity cycle is put into action. The intent of the execution phase of the project activity cycle is to bring about the project's expected results. Normally, this is the longest phase of the project management life cycle, where most resources are applied.

Monitoring and Control

This process oversees all the tasks and metrics needed to guarantee that the agreed and approved project that is undertaken is within scope, on time and within budget so that the project proceeds with minimum risk.

Close

This is considered to be the last process of the project activity cycle. In this stage, the project is formally closed and then a report is produced to the project sponsor/client on the overall level of success of the completed project.

CHAPTER -V
Classification of project management
Dr. S. Venkatesh, Department of Management,
Ponnaiyah Ramajayam Institute of Science and Technology(PRIST)

Importance of Categorizing Projects in Management

- **Strategic Planning:** Understanding different project types allows organizations to align their projects with their strategic goals. By categorizing projects based on their nature, scope, and purpose, management can better allocate resources and prioritize initiatives that align with the overall organizational objectives.
- **Resource Allocation:** Different projects require varying resources in terms of finances, human resources, time, and expertise. Moreover, it ensures that the right resources are applied to each project in accordance with its specific needs when categorizing them.
- **Risk Management:** Categorizing projects enables the identification of potential risks associated with each type of project. By recognizing the common risks linked to specific project types, management can proactively plan risk mitigation strategies and allocate contingency resources accordingly.
- **Specialized Management Approaches:** Different projects often call for technical management approaches. Understanding the categories helps select and implement the most suitable project management methodologies and techniques, ensuring better project outcomes.
- **Performance Evaluation and Learning:** Categorizing projects facilitates better evaluation and learning from past experiences. As a result of grouping similar projects, management can analyze their successes, failures, and best practices for improving project performance.
- **Client and Stakeholder Expectations:** Categorizing projects helps manage and set appropriate expectations for clients and stakeholders. Each project type may have unique deliverables and timelines, which, when categorized and communicated effectively, result in more explicit expectations and satisfaction among stakeholders.

In conclusion, categorizing projects in management is pivotal for effective planning, resource allocation, risk management, specialized approaches, learning from experiences, and meeting stakeholder expectations. This classification assists in understanding the diverse nature of projects and guides the application of suitable strategies for successful project execution.

CHAPTER -VI

Cost Schedule Integration and Productivity Analysis

K.Sasikumar, Department of Management,

Ponnaiyah Ramajayam Institute of Science and Technology(PRIST)

A majority of industry (large) capital projects use a cost and schedule risk analysis to estimate the amount of cost and schedule contingency needed to center the base estimates and deterministic schedule. IPA defines cost contingency as an amount added to an estimate to allow for items, conditions, or events for which the state, occurrence, or effect is uncertain and that experience shows will likely result, in aggregate, in additional costs. It is meant to cover inadequacies in complete project scope definition, estimating methods, and estimating data. Contingency excludes scope changes, extraordinary events (e.g., strikes and disasters), management reserves, and escalation/currency effects. Essentially, contingency funds are expected to be spent during the project, but the project team is not sure what item will consume the cost in actuality.

Similarly, for schedule, most large projects conduct a Monte Carlo schedule risk analysis, which is an AACEI Recommended Practice[1], and traditionally accepted to be Best Practice for schedule target setting. IPA research[2] has shown that while most owner companies expect a ± 10 percent accuracy for their authorization estimates prepared at the end of FEL 3, Industry has, on average, observed a $-17/+42$ percent accuracy on their completed projects; that is, 80 percent of completed projects had cost growth between -17 and $+42$ percent from their planned cost estimate (including contingency) at the end of FEL 3. Similarly, if we look at capital projects with costs greater than \$10 million (²⁰²²US\$) that were completed over the past decade, 80 percent of those projects observed schedule slip between -4 and $+55$ percent.

RISK ANALYSIS CHALLENGES

IPA has seen significant variability in the level of maturity across owner companies in terms of implementation of these cost and schedule risk analysis Best Practices. For example, we see project teams conduct purely qualitative risk analysis on schedule, basic quantitative analysis that includes the traditional activity range estimating, modern quantitative analysis that includes risk drivers specified by probability and effect and assigned to all activities they affect, and finally the advanced integrated cost-schedule risk analysis.

Getting any of these methods to work is hard. For example, one of the challenges in getting a Monte Carlo schedule analysis to work is estimating correlations between activity durations in an effective fashion. Similarly, Monte Carlo-based methods for cost contingency setting fail because, while they focus on individual cost element distributions, cost estimates overrun because the scope was not all defined and not because the distribution around the individual elements was incorrect. Most industry projects use fabricated distributions, which are not based on historically observed and unbiased distributions of outcomes. Additionally, these analyses assume orthogonality of the distributions, which denies the reality of projects that most things are intimately connected.

CHAPTER -VII

Advanced Scheduling Techniques – Linear Scheduling

Dr K G Selvan, Department of Management,

Ponnaiyah Ramajayam Institute of Science and Technology (PRIST)

1 Use of Advanced Scheduling Techniques

Construction project scheduling is a topic that has received extensive research over a number of decades. The previous chapter described the fundamental scheduling techniques widely used and supported by numerous commercial scheduling systems. A variety of special techniques have also been developed to address specific circumstances or problems. With the availability of more powerful computers and software, the use of advanced scheduling techniques is becoming easier and of greater relevance to practice.

2 Scheduling with Uncertain Durations

Section 10.3 described the application of *critical path scheduling* for the situation in which activity durations are fixed and known. Unfortunately, activity durations are estimates of the actual time required, and there is liable to be a significant amount of uncertainty associated with the actual durations. During the preliminary planning stages for a project, the uncertainty in activity durations is particularly large since the scope and obstacles to the project are still undefined. Activities that are outside of the control of the owner are likely to be more uncertain. For example, the time required to gain regulatory approval for projects may vary tremendously. Other external events such as adverse weather, trench collapses, or labor strikes make duration estimates particularly uncertain.

3 Calculations for Monte Carlo Schedule Simulation

In this section, we outline the procedures required to perform Monte Carlo simulation for the purpose of schedule analysis. These procedures presume that the various steps involved in forming a network plan and estimating the characteristics of the probability distributions for the various activities have been completed. Given a plan and the activity duration distributions, the heart of the Monte Carlo simulation procedure is the derivation of a *realization* or synthetic outcome of the relevant activity durations. Once these realizations are generated, standard scheduling techniques can be applied. We shall present the formulas associated with the generation of normally distributed activity durations, and then comment on the requirements for other distributions in an example.

4 Crashing and Time/Cost Tradeoffs

The previous sections discussed the duration of activities as either fixed or random numbers with known characteristics. However, activity durations can often vary depending upon the type and amount of resources that are applied. Assigning more workers to a particular activity will normally result in a shorter duration. Greater speed may result in higher costs and lower quality, however. In this section, we shall consider the impacts of time, cost and quality tradeoffs in activity durations. In this process, we shall discuss the procedure of *project crashing* as described below.

5 Scheduling in Poorly Structured Problems

The previous discussion of activity scheduling suggested that the general structure of the construction plan was known in advance.

CHAPTER -VIII
Change Management
Dr T J Jayasholan, Department of Management,
Ponnaiyah Ramajayam Institute of Science and Technology(PRIST)

Change Management for Project Management

Because each change request must get reviewed for its influence on the project, change management is critical in project management. Project managers, or senior executives in charge of change control, must consider how a change in one area of the project may affect others and the impact that changes may have on the whole project. Change control professionals should give special attention to the following project areas:

1. Scope

Change requests must get reviewed to determine their impact on the project scope.

2. Schedule

Change requests must get evaluated to determine how they will affect the project's timeline.

3. Costs

Change requests must get assessed to determine their impact on project expenses. Labor is often the most expensive component of a project, so delays in executing project activities can quickly cause changes in project costs.

4. Quality

Change requests must get examined to determine how they will impact the overall quality of the project.

5. Human Capital

Requests for changes must get examined to see whether additional or specialist labor is required. When the project timetable changes, the project manager may have to delegate critical resources to other tasks.

6. Communications

Change requests that get approved must get conveyed to the right stakeholders at the appropriate time.

7. Risk

Change requests must get assessed to determine the risks they entail. Minor modifications might have a cascading effect on the project, introducing logistical, financial, and security problems.

8. Procurement

Changes to the project may impact material procurement and contract labor. When an incremental change is authorized, the project manager documents it in one of four change control systems to ensure that all thoughts and insights get included with the change request. Defects are changes that do not get entered into a control system. When a modification request gets denied, it gets documented and saved in the project archives.

CHAPTER -IX
Network Modeling and Analysis
K. Sasikumar, Department of Management,
Ponnaiyah Ramajayam Institute of Science and Technology(PRIST)

The 20th century witnessed a crucial paradigm shift in social and behavioral sciences, which can be described as “moving from the description of social bodies to dynamic problems of changing group life” (Lewin, 1947). Unlike individualistic approaches, focused on individual choices and interests of social actors, the emerging theories dealt with structural properties of social groups, organizations and movements, focusing on social relations (or ties) among their members.

A breakthrough in the analysis of social groups was enabled by introducing a quantitative method for describing social relations, later called *sociometry* (Moreno, 1934, Moreno, 1951). The pioneering work Moreno (1934) introduced an important graphical tool of *sociogram*, that is, “a graph that visualizes the underlying structure of a group and the position each individual has within it” (Moreno, 1934). The works Moreno (1934); 1951) also broadly used the term “network”, meaning a group of individuals that are “bound together” by some long-term relationships. Later, the term *social network* was coined, which denotes a structure, constituted by *social actors* (individuals or organizations) and *social ties* among them. Sociometry has given birth to the interdisciplinary science of Social Network Analysis (SNA) (Freeman, 2004, Scott, 2000, Scott, Carrington, 2011, Wasserman, Faust, 1994), extensively using mathematical methods and algorithmic tools to study structural properties of social networks and social movements (Diani & McAdam, 2003). SNA is closely related to economics (Easley, Kleinberg, 2010, Jackson, 2008), political studies (Knoke, 1993), medicine and health care (O’Malley & Marsden, 2008). The development of SNA has inspired many important concepts of modern network theory (Newman, 2003a, Newman, Barabasi, Watts, 2006, Strogatz, 2001) such as e.g. cliques and communities, centrality measures, small-world network, graph’s density and clustering coefficient.

On a parallel line of research, Norbert Wiener introduced the general science of Cybernetics (Wiener, 1948, Wiener, 1954) with the objective to unify systems, control and information theory. Wiener believed that this new science should become a powerful tool in studying social processes, arguing that “society can only be understood through a study of the messages and communication facilities which belong to it” (Wiener, 1954). Confirming Wiener’s ideas, the development of social sciences in the 20th century has given birth to a new chapter of sociology, called “sociocybernetics” (Geyer, 1995) and led to the increasing comprehension that “the foundational problem of sociology is the coordination and control of social systems” (Friedkin, 2015). However, the realm of social systems has remained almost untouched by modern control theory in spite of the tremendous progress in control of complex large-scale systems (Annaswamy, Chai, Engell, Hara, Isaksson, Khargonekar, Lamnabhi-Lagarrigue, Murray, Nijmeijer, Samad, Tilbury, den Hof, 2017, Murray, 2003, Samad, Annaswamy, 2011).

CHAPTER -X

Focuses on the development of financial and operational plans

K. Sasikumar, Department of Management,

Ponnaiyah Ramajayam Institute of Science and Technology(PRIST)

What does operational planning mean? Operational planning is a process that involves creating a detailed roadmap to align with a strategic plan.

The operational plan itself is a document that outlines timelines, action items, and critical milestones for executing the strategic plan. This document defines the organization's objectives and goals and clarifies how to achieve them.

An operational planning process involves examining how a business operates and laying out who's responsible for what and when.

Remember, every company approaches this differently, and annual operational plans are constantly updated or changed. The key to making it work? Clear and collaborative communication.

The timeframe to execute a plan typically depends on an organization's velocity. For example, creating an annual operational plan is a fluid, changing process.

A well-conceived business operational plan keeps team members collaborating smoothly, ensures everyone knows what needs to be done and what their part is, and guides critical decisions about long-term strategy.

Critical steps of operational planning

Clearly define the goal or vision for the operational plan.

Analyze and identify essential business stakeholders, team members, budgets, and resources.

1. Clearly define the goal or vision for the operational plan.
2. Analyze and identify essential business stakeholders, team members, budgets, and resources.
3. Accurately plan for risk.
4. Consistently track performance.
5. Communicate to team members and stakeholders about progress.
6. Adapt the operational plan to broader company goals as needed.

Examples of operational planning:

- A manufacturing company is developing a plan to boost revenue by 30%.
- Finance collaborating with sales, marketing, operations management, and other vital areas to align strategies supporting revenue growth and achieving business goals.
- A brand planning to launch a new product involves market research, R&D, manufacturing, supply chain, logistics, distribution, sales, marketing, and customer support.

INTERNATIONAL BUSINESS

EDITED BY

DR. M BALAMURUGAN



978-93-6255-733-9

International Business

Copyright © 2023 by DR. M. BALAMURUGAN

All rights reserved. No part of this book may be reproduced or transmitted in any form or by any means without written permission from the author.

ISBN: 978-93-6255-733-9

Publisher: Ponnaiyah Ramajayam Institute of Science and Technology (PRIST)

TABLE OF CONTENTS

| | |
|---|-----|
| CHAPTER-I | 1 |
| Stages of internationalisation Dr K G Selvan | |
| CHAPTER -II | 09 |
| factors of international business environment MRS. P. UMA ESWARI | |
| CHAPTER -III | 21 |
| decision factors Dr.S.Saranya | |
| CHAPTER -IV | 36 |
| Advantages of internationalisation Dr. S. Venkatesh | |
| CHAPTER -V | 50 |
| Forms of Exporting Dr K G Selvan | |
| CHAPTER -VI | 62 |
| Theories of international trade Dr. M. Balamurugan | |
| CHAPTER -VII | 73 |
| Merit of contract manufacturing K.Sasikumar | |
| CHAPTER -VIII | 83 |
| Basic issues in international licensing Dr K G Selvan | |
| CHAPTER -IX | 95 |
| Political environment concept Dr T J Jayasholan | |
| CHAPTER -X | 111 |
| Impact of technology on globalisation Dr. S. Venkatesh | |
| REFERENCES | 119 |

CHAPTER -I

Stages of internationalisation

Dr K G Selvan, Department of Management,

Ponnaiyah Ramajayam Institute of Science and Technology(PRIST)

Stage 1 : Domestic Operations - The Firm is said to have a domestic market if it purely confines its operation in the home country. Most of the international firms initiate their operations as domestic firms. Most of the international firms originated initially as domestic firms. Domestic firms usually have ethnocentric orientation because at the very initial stage they do not consider going international as an option for its growth. The firm continues with its national model of operation for some time and when the growth gets stagnated, it expands and diversifies to new markets within the home country instead of focusing on the international markets. However the diminishing prospects in the domestic market and increased opportunities in the international markets encourage the firm to redevelop and fine tune its strategies to explore international market opportunities and the firm moves to the next level in the evolution and market its products to foreign markets through suitable internationalization technique viz., direct exports, franchise and licensing.

Stage 2 : Foreign Operations (Export) – In this stage the firm expands its market through sales efforts and the production done in the domestic market. Firm expands its market to other countries through sales effort and retains the production facilities in the domestic market. For examples Indian firms export nuts spices textiles, Jute and Rice all around the world. Domestic firms being ethnocentric start its internationalization by initially involving in just exporting goods to the foreign countries which has high demand.

Stage 3 : Joint Ventures or Subsidiaries - Subsidiaries or joint ventures are the business agreements in which firm physically transfers some of its operations out of its home country and establishes in a foreign country. The firm in this agreement goes for a mutual cost and profit sharing and management involved with a firm which is existing in the host country. Firm then moves from international operations being in the home country to investment expansions in the foreign country moves to a stage from international to Multinational and Transnational firms.

Stage 4 : Multinational Operations - In this stage a firm becomes a fullfledged multinational corporation (MNC) with multiple production facilities established across the several locations in the world. An International firm demands a greater degree of decentralization in decision making though important decision in this system is always taken at corporate head quarter. These firms operate worldwide and the orientation of the firm shifts from ethnocentric to polycentric. A multinational firm decides to respond to market differences vis a vis social, cultural and legal requirements and evolve as a stage three MNC which pursues a multi domestic strategy. In 113 MNCs each foreign subsidiary is managed as an independent entity. The Internationalization Process subsidiaries are a part of regional structure in which every country has its own organization and reports to world headquarters.

Stage 5 : Transnational Operations -Firms which achieve global efficiency and local responsiveness are called as transnational firms. These firms are highly decentralized in terms of decision making. Every transnational business unit has freedom to take its decision with very minimal control from corporate headquarters. However, there is no pure transnational firm and these firms satisfy the characteristics of the global corporation. Table 6.1 gives a brief about the firm attributes at different levels.

CHAPTER -II
Factors of international business environment
MRS. P. UMA ESWARI, Department of Management,
Ponnaiyah Ramajayam Institute of Science and Technology(PRIST)

Step 1: Conducting a SWOT Analysis

The first step in the business planning process is to conduct a SWOT analysis. SWOT stands for Strengths, Weaknesses, Opportunities, and Threats. This analysis will help you understand your business's internal and external environment, and it can help you identify areas of improvement and growth.

Strengths and weaknesses refer to internal factors such as the company's resources, capabilities, and culture. Opportunities and threats are external factors such as market trends, competition, and regulations.

Step 2: Defining Your Business Objectives

Once you have conducted a SWOT analysis, the next step is to define your business objectives. Business objectives are specific, measurable, achievable, relevant, and time-bound (SMART) goals that align with your business's mission and vision.

Step 3: Conducting Market Research

Market research should always be a part of your strategic business planning. This step gathers information about your target audience, competitors, and industry trends. This information can help you make informed decisions about your product or service offerings, pricing strategy, and marketing campaigns.

Step 4: Identifying Your Target Audience

Identifying your target audience is essential in the business planning process. Your target audience is the group of people who are most likely to buy your product or service. Understanding their needs, preferences, and behaviors can help you create effective marketing campaigns and improve customer satisfaction.

Step 5: Developing a Marketing Plan

A marketing plan is a strategic roadmap that outlines your marketing objectives, strategies, tactics, and budget. Your marketing plan should align with your business objectives and target audience and include a mix of online and offline marketing channels.

Step 6: Creating a Financial Plan

A financial plan is a detailed document that outlines your business's financial projections, budget, and cash flow. Your financial plan should include a balance sheet, income statement, and cash flow statement, and it should be based on realistic assumptions and market trends.

Step 7: Writing Your Business Plan

The final step in the business planning process is to write your business plan. A business plan is a comprehensive document that outlines your business's mission, vision, objectives, strategies, and financial projections.

CHAPTER -III

Decision factors

**Dr.S.Saranya, Department of Management,
Ponnaiyah Ramajayam Institute of Science and Technology(PRIST)**

The decision makers

Different people approach decision making in different ways. Individuals are unique in terms of their personalities, abilities, beliefs and values. They also each have traditions of understanding out of which they think and act. Even when the same data is apparently available to all, people will interpret and assimilate the data in different ways and at different speeds. Some people are very confident about weighing up a situation and making decisions, others less so. Some like to take more risks than others. Competences, such as the ability to listen to other people, also vary. Social pressures affect everyone to varying degrees and the approval or disapproval of friends and colleagues may be more important to the decision maker than being 'right' every time. Political beliefs also vary and people will rank differently, for example, individual and social gains from a situation.

2 The decision situation

The garbage-can approach to decision making showed that the decision situation is often messy and complex and that apparently unrelated events can affect decision outcomes, depending on what else is going on at the time the decision is taken. For any individual or group there will be both 'knowns' and 'unknowns' in a decision situation. In the examples so far, in the text and in the answer to **Activity 1**, the unknowns range from prices and models of computers to weather conditions and availability of people. It is not always easy to work out which aspects of a decision situation are relevant.

Elements of change, risk and uncertainty are common in decision situations and recognising and making sense of these elements are two of the main challenges that decision makers face. Risk implies that we know what the possible outcomes of a decision may be and that we know, or can work out, the probability of each outcome. Uncertainty, on the other hand, implies that there are unknowns and that we can at best guess at possible outcomes and their probabilities or consider a range of imagined scenarios. There are ways of reducing some of these unknowns by using relevant data, techniques (for example, 'what if' modelling) and the experience of participants.

3 Thinking in terms of a problem or an opportunity

A potential problem can often be turned around by thinking about it differently. For example, Shields Environmental in the UK has developed a business that provides two specialist services – reuse/recycling of mobile phones and reuse/recycling of telecommunications network equipment. Fonebak was one scheme they have developed. It was the world's first mobile phone recycling scheme to comply with all legislation. Over 18 million phones each year were being replaced in the UK around 2000 and without opportunities for reuse and recycling would have probably gone as potentially hazardous waste to landfill. In Fonebak's first two years of operation (2002– 04) the company processed 3.5 million mobile phones for reuse and recycling, from 10,000 collection points across Europe.

CHAPTER -IV
Advantages of internationalisation
Dr. S. Venkatesh, Department of Management,
Ponnaiyah Ramajayam Institute of Science and Technology(PRIST)

Introduction

The internationalisation of a company is a strategic step that can bring numerous benefits and opportunities. When a company expands its operations to international markets, it can experience significant growth, increased revenue and brand strengthening. In this article, we'll discuss the four main benefits of internationalisation and how this process can boost a company's success.

1. Increased Market Potential

By internationalising its business, a company has the opportunity to access a much larger potential market. This means that it will be able to reach a greater number of customers around the world, which can result in a significant increase in sales and revenue. By expanding into new markets, the company also reduces its dependence on a single market, making it more resilient to economic fluctuations and political instability.

2. Revenue Diversification

Internationalisation allows a company to diversify its sources of income. By entering new markets, the company can capitalise on unique opportunities and tap into different customer segments. This helps mitigate the risks associated with relying on just one market or product. Furthermore, by offering its products or services in different currencies, the company can also protect itself against currency fluctuations and economic volatility in its home market.

3. Strengthening the Brand and Credibility

When a company expands internationally, it has the opportunity to strengthen its brand globally. By gaining the trust of consumers in different countries, the company increases its reputation and credibility in the international market. This can open doors to strategic partnerships, collaborations and future growth opportunities. What's more, a well-established international brand is more likely to attract investors and expand its customer base.

4. Innovation and learning

By venturing into new markets, companies are exposed to different cultures, business practices and consumer needs. This stimulates innovation and continuous learning within the company.

Internationalisation promotes the exchange of ideas and knowledge between multidisciplinary teams, which can lead to the development of improved products or services. Furthermore, by competing in international markets, the company is encouraged to adapt to changes and keep up to date with the latest trends and technologies.

CHAPTER V

Forms of Exporting

*Dr K G Selvan, Department of Management,
Ponnaiyah Ramajayam Institute of Science and Technology (PRIST)*

1. Starting the market expansion

Companies planning an export must first set up a market expansion program. Leaders should be assigned their tasks, and the organization should establish an export team. They must also define actions that need to be taken to expand into the desired market. The business will also determine a long-term financial plan with its objectives and review and assess the results to make changes if needed.

2. Selecting products with export potential

Marketers must then select the products with the most potential of thriving abroad from their product line. After determining the products, it is crucial to identify and form good relationships with the export promotion organizations. Marketers then collect information and screen the market to examine its potential. The collected information is then analyzed, and the best-suited markets are selected. The company then evaluates this information further and changes its product and market selection if its previous decisions were incorrect.

3. Developing market-expansion plans

This step focuses on building market expansion plans. Marketers review the different entry modes, and the best-fitted strategy is selected.

After selecting the markets, the organization identifies the most effective distribution channels. The company will then have to find distribution channel partners. The next crucial step is identifying direct and indirect competitors in the new market and understanding their products and customers.

4. Developing an export organization

The next step includes determining an export organization. Here, marketers should:

- Develop and adjust the export policies for increased efficiency,
- Set up export teams throughout the company,
- Hire the necessary staff and provide the required training,
- Select the most suitable export service organization,
- Identify necessary approvals.

5. Designing a distribution network

The following step includes designing a distribution network. For this stage to be successful, marketers must:

1. Find and recruit distribution partners,
2. Filter and process all the potential distribution partners,
3. Select partners that can match the company's budget and scale,
4. Discuss terms and agreements with the partners and reach an agreement,
5. Evaluate the terms and sign a contract after consideration.

6. Starting the Export

It is now finally time to start exporting! During this last stage, marketers should:

- Implement the export strategies designed in the earlier stages,
- Respond to sale inquiries and finalize the deals,
- Discuss the quantity and pricing strategies that work for both companies,

CHAPTER -VI
Theories of international trade
Dr. M. Balamurugan, Department of Management,
Ponnaiyah Ramajayam Institute of Science and Technology(PRIST)

Classical Theory of International Trade

The details of the theory are stated below.

- The absolute advantage theory states that a nation should specialize in and export the goods with an absolute cost advantage over other nations.
- A nation has an absolute advantage in making a good if it can make that good at a lower absolute cost reached to other nations.

Comparative Advantage Theory of International Trade

The details of the comparative advantage theory on international trade have been stated below.

- The comparative advantage theory of trade was propounded by David Ricardo.
- It is also called the Ricardian theory of international trade, comparative cost theory of international trade, the law of comparative advantage, relative cost theory, the principle of comparative advantage and opportunity cost theory of international trade theory.
- It states that a nation should focus on creating and exporting the goods for which it has a lower opportunity cost than its trading partners, even if it has an absolute penalty.

Pure Theory of International Trade

The details of the pure theory of international trade are mentioned below.

- It was developed in the early 19th century as part of David Ricardo's work, making it one of the earliest trade theories.
- It focuses on comparative costs of production and factor endowments as the main determinants of trade, in line with other classical theories.
- It relies on beliefs that depict classical trade theories, like perfect competition, freely mobile factors of production and no trade barriers.

Heckscher Ohlin Theory of International Trade

The details of the theory are stated below.

- The factor proportion theory, also known as the Heckscher-Ohlin theory, states that international trade patterns are determined by the relative abundance of factors of production in different countries.
- It is also called the factor endowment theory of international trade.
- The factors of production are land, capital, labour and entrepreneurship. Nations will have several levels of plenty of these factors.

Mercantilism Theory of International Trade

The details of Mercantilism have been stated below.

- Mercantilism was an economic theory that dominated Western European nations among the 16th and 18th centuries.
- It held that a nation's wealth and power came from the assembly of gold and silver. A "favourable" trade balance was seen as crucial to gaining gold and silver.
- Mercantilist thinking enabled colonialism and the acquisition of new markets for domestic goods. Colonies were seen as a source of raw materials and a captive market for finished goods.

CHAPTER -VII
Merit of contract manufacturing
K.Sasikumar, Department of Management,
Ponnaiyah Ramajayam Institute of Science and Technology(PRIST)

Meaning

Contract manufacturers are not just the supply chain vendors. The right contract manufacturer can provide insight and guidance to optimize the organization's product design for manufacturing, end-user satisfaction, and sometimes even keep assembly projects on track.

Below are some of the key benefits of Contract Manufacturing,

Cost Reduction:

Contract Manufacturing helps companies to save on their capital costs. Companies do not need to pay for production facilities and equipment. Different cost heads like labor, wages, training, and other benefits can reduce to a greater extent.

Business Assurance:

A contract between two organizations may last several years. With contract manufacturing, the manufacturer can have the assurance to get a steady flow of business at least until the contract expires.

Advanced Skills:

Companies can take advantage of skills that they may not possess, but the contract manufacturer does. As an expert, the contract manufacturer is likely to have advanced skills and efficient techniques for production.

Economies of Scale:

Contract Manufacturers have multiple customers and multiple product portfolios. As they are servicing multiple customers, they can offer reduced costs in acquiring raw materials by getting an advantage from economies of scale.

End-to-End Options:

Contract manufacturing facilitates companies to concentrate on their core competencies and business management. Several contract manufacturers offer end-to-end services, meaning that they handle the entire process from start to finish. It helps to keep the entire process under one roof and reduces costs and other complexities.

CHAPTER -VIII
Basic issues in international licensing
Dr K G Selvan, Department of Management,
Ponnaiyah Ramajayam Institute of Science and Technology(PRIST)

Licensing

Licensing is a business arrangement in which one company gives another company permission to manufacture its product for a specified payment. Licensing is defined as the granting of permission by the licensor to the licensee to use intellectual property rights, such as trademarks, patents, brand names, or technology, under defined conditions. The possibility of licensing makes for a flatter world, because it creates a legal vehicle for taking a product or service delivered in one country and providing a nearly identical version of that product or service in another country. Under a licensing agreement, the multinational firm grants rights on its intangible property to a foreign company for a specified period of time. The licensor is normally paid a royalty on each unit produced and sold. Although the multinational firm usually has no ownership interests, it often provides ongoing support and advice. Most companies consider this market-entry option of licensing to be a low-risk option because there's typically no up-front investment.

For a multinational firm, the advantage of licensing is that the company's products will be manufactured and made available for sale in the foreign country (or countries) where the product or service is licensed. The multinational firm doesn't have to expend its own resources to manufacture, market, or distribute the goods. This low cost, of course, is coupled with lower potential returns, because the revenues are shared between the parties.

Licensing generally involves allowing another company to use patents, trademarks, copyrights, designs, and other intellectual in exchange for a percentage of revenue or a fee. It's a fast way to generate income and grow a business, as there is no manufacturing or sales involved. Instead, licensing usually means taking advantage of an existing company's pipeline and infrastructure in exchange for a small percentage of revenue.

An international licensing agreement allows foreign firms, either exclusively or non-exclusively, to manufacture a proprietor's product for a fixed term in a specific market.

To summarize, in this foreign market entry mode, a licensor in the home country makes limited rights or resources available to the licensee in the host country. The rights or resources may include patents, trademarks, managerial skills, technology, and others that can make it possible for the licensee to manufacture and sell in the host country a similar product to the one the licensor has already been producing and selling in the home country without requiring the licensor to open a new operation overseas. The licensor's earnings usually take the form of one-time payments, technical fees, and royalty payments, usually calculated as a percentage of sales.

CHAPTER -IX
Political environment concept
Dr T J Jayasholan, Department of Management,
Ponnaiyah Ramajayam Institute of Science and Technology(PRIST)

Environmental politics designate both the politics about the environment and an academic field of study focused on three core components:

- The study of political theories and ideas related to the environment;
- The examination of the environmental stances of both mainstream political parties and environmental social movements; and
- The analysis of public policymaking and implementation affecting the environment, at multiple geo-political levels.

Neil Carter, in his foundational text *Politics of the Environment* (2009), suggests that *environmental* politics is distinct in at least two ways: first, "it has a primary concern with the relationship between human society and the natural world" (page 3); and second, "unlike most other single issues, it comes replete with its own ideology and political movement" (page 5, drawing on Michael Jacobs, ed., *Greening the Millenium?*,1997).

Further, he distinguishes between modern and earlier forms of environmental politics, in particular conservationism and preservationism. Contemporary environmental politics "was driven by the idea of a global ecological crisis that threatened the very existence of humanity." And "modern environmentalism was a political and activist mass movement which demanded a radical transformation in the values and structures of society."

Environmental concerns were rooted in the vast social changes that took place in the United States after World War II. Although environmentalism can be identified in earlier years, only after the war did it become a widely shared social priority. This began with outdoor recreation in the 1950s, extended into the wider field of the protection of natural environments, and then became infused with attempts to cope with air and water pollution and still later with toxic chemical pollutants. After World War II, environmental politics became a major public concern. The Post-war era resulted in the 'Great Acceleration', which saw a dramatic increase in industrialization, agriculture, and consumption of resources leading to a new geological era of environmental deficit. The development of environmentalism in the United Kingdom emerged in this period following the great London smog of 1952 and the Torrey Canyon oil spill of 1967. This is reflected by the emergence of Green politics in the Western world beginning in the 1970s. Notably, the 1972 United Nations Conference on the Human Environment in Stockholm marked the entry of environmental politics into the international agenda, giving rise to new environmental political thought and its incorporation into policymaking. Since then, environmentalism has taken shape as its own political ideology and has had numerous variations, from more radical theories like 'deep ecology' which seeks to prioritize environmental needs to more reformist ideologies which view environmental damage as an externality.

CHAPTER -X
Impact of technology on globalisation
Dr. S. Venkatesh, Department of Management,
Ponnaiyah Ramajayam Institute of Science and Technology(PRIST)

Impact of technology on globalisation

Advancements in technology have considerably facilitated globalization. In fact technological progress has been one of the main forces driving globalization. Technological breakthroughs compel business enterprises to become global by increasing the economies of scale and the market size needed to break even.

Technological advancements reduce costs of transportation and communication across nations and thereby facilitate global sourcing of raw materials and other inputs. Patented technology encourages globalization as the firm owning the patent can exploit foreign markets without much competition.

Information technology has led to the emergence of the global village. For example, the world wide web has reduced the barriers of time and place in business dealings. Buyers and sellers can now make transactions at any time and any part of the globe. Technological change also affects investments.

Earlier, high technology production was limited to rich countries with high wages. Now technology is easily transferable to developing countries where high tech production can be combined with low wages. A large number of firms in advanced countries are now outsourcing labour intensive services from developing countries like India.

Technological progress is a key driver of improvements in incomes and standards of living. But new knowledge and technologies do not necessarily develop everywhere and at the same time. Therefore, the way technology spreads across countries is central to how global growth is generated and shared across countries.

Indeed, during 1995–2014, the United States, Japan, Germany, France, and the United Kingdom (the G5) produced three-fourths of all patented innovations globally. Other large countries—notably China and Korea—have started to make significant contributions to the global stock of knowledge in recent years, joining the top five leaders in a number of sectors. While this suggests that in the future they too will be important sources of new technology, during the period under study, the G5 constituted the bulk of the technology frontier.

To trace knowledge flows, our study uses the extent to which countries cite patented innovations from the technology leaders as prior knowledge in their own patent applications. The chart below gives a representation of these cross-country knowledge links. Two features stand out. First, while in 1995 the United States, Europe, and Japan were dominating global patent citations, China and Korea (depicted together as “other Asia”) have made increasingly large use of the global knowledge stock as measured by

CUSTOMER RELATIONSHIP MANAGEMENT

Edited by

M.N.KASTHURIPRIYA



978-93-6255-917-3

Customer Relationship Management

Copyright © 2023 by M.N. KASTHURIPRIYA

All rights reserved. No part of this book may be reproduced or transmitted in any form or by any means without written permission from the author.

ISBN: 978-93-6255-917-3

Publisher: Ponnaiyah Ramajayam Institute of Science and Technology (PRIST)

TABLE OF CONTENTS

| | |
|--|-----|
| CHAPTER-I | 1 |
| Features of E- CRM Dr. P. Balasubramanian | |
| CHAPTER –II | 14 |
| Enterprise Marketing Automation Dr. K. Rajalakshmi | |
| CHAPTER –III | 23 |
| Principles of CRM M.N.Kasthuripriya | |
| CHAPTER –IV | 30 |
| Software application in CRM. Mrs. P. Uma Eswari | |
| CHAPTER -V | 49 |
| Customer Centric Approach: Dr. T. J. Jayasholan | |
| CHAPTER -VI | 60 |
| Challenges and Best practices Dr. K. G. Selvan | |
| CHAPTER –VII | 69 |
| Cost Benefit Analysis of CRM K.Sasikumar | |
| CHAPTER -VIII | 83 |
| Introduction to Database Management, DR. P. Balasubramanian | |
| CHAPTER -IX | 95 |
| Levels of Data Abstraction, Dr T J Jayasholan | |
| CHAPTER –X | 105 |
| CRM Process in Marketing and Service Organization. Dr. S. Venkatesh | |
| REFERENCES | 109 |

CHAPTER -I
Features of E- CRM
Dr. P. Balasubramanian, Department of Management,
Ponnaiyah Ramajayam Institute of Science and Technology(PRIST)

1. Contact Management

Contact management, an element of CRM that sometimes goes by customer management software, is one of the most important CRM functions. It allows users to segment their contacts into groups to organize and better cater to them.

With this CRM capability, you'll be able to gather crucial customer data and bolster your marketing strategies when introducing new products. It also improves the personalization of all contacts with customers, making them feel important and catered to. This is a key factor in customer satisfaction!

2. Sales Team and Customer Opportunity Management

Quantifying the opportunities that your sales team has with customers is a relatively basic feature of CRM. Referred to as lead scoring, it allows users to identify the customers that are most likely to convert. This helps streamline sales/marketing teams, improve efficiency and optimize your sales process.

3. Lead Management

No CRM feature list would be complete without mentioning lead management. This technology allows a business to determine the best customers to follow up with based on demographic and psychographic factors. Like lead scoring, it improves the efficiency and productivity of your sales team by helping them focus on the right leads at the right time.

4. Reports and Dashboards

Once relegated to business intelligence tools, BI, reporting and dashboards have become some of the top CRM functions. Users can view statistics in a highly visual, engaging perspective using customized reports and dashboards.

They offer real-time data updates and a platform that can be accessed from various portals, improving ease of access for a variety of personnel. Management can use these reports to make data-driven decisions — an investment in CRM BI is an investment in the future of your business.

5. Sales Analytics

On the subject of reporting, sales analytics is one of the most valuable features of CRMs. Users can create better sales campaigns in the future by analyzing the hard data of past campaigns. CRM helps you collect data from social media, polls and website traffic, and then analyze it — all with the same software.

6. Mobile CRM

Everyone has a smartphone these days, so it makes sense to utilize the amazing technology inside them to benefit your business. Take customer relationship management remotely mobile CRM programs and apps. Staff can view data and receive valuable alerts about campaigns on a mobile device.

7. Sales Force Automation

Another of the many features of CRM is the ability to automate certain aspects of your sales process. This includes outgoing calls and follow-up campaigns, as well as data organization for more effective future campaigns. Automating these repetitive tasks allows your employees to devote their time and focus to more complex tasks.

CHAPTER -II
Enterprise Marketing Automation
Dr. K. Rajalakshmi, Department of Management,
Ponnaiyah Ramajayam Institute of Science and Technology(PRIST)

Functions of Enterprise Marketing Automation

Automation is a familiar word to every industry, and knowing the actual definition of enterprise marketing automation and its functions becomes extremely important to use the technology and software optimally.

Automated Email Marketing

A statistical report states automated emails yield 320% more revenue than manually executed marketing emails. With enterprise marketing platforms such as HubSpot, you can step ahead to scale up your across-the-board marketing efforts. There is no need to jump profoundly and put much effort when automation can help to facilitate triggered emails, scheduled messages, personalized communication, email group segmentation, and performance tracking processes.

Automated Lead Management

Lead management is as crucial as lead generation, and HubSpot's marketing automation platform can help you effectively manage all business leads and prevent them from falling through a time gap. Giving a boost to your communication, the automation platform helps streamline different steps in the lead management process, lead information consolidation, and lead analytics improvement.

Interface and Integration

Getting an app with a highly intuitive interface and easy setup aligns with the best ways to make efficient workflows and reduce staff training time. Additionally, businesses can easily sync their essential data from other marketing tools and third-party integration processes for easy organizational task management.

Multi-Channel Campaign Management

There are many channels to communicate with customers and clients. Businesses are reaching out to their customers through different tools like CRM, social platforms, and the QR code generator, to name a few. With enterprise marketing automation, it becomes easy to seamlessly orchestrate several campaigns across social media, emails, and websites.

Automated Segmentation

Lead segmentation is a necessary process that directly impacts the time and financial resource management to increase business ROI. Businesses leveraging automation to trigger and segment leads have been effectively promoting personalized communication and a significant increase in lead conversions.

Advanced Analytics

Enterprise marketing automation has robust analytics capabilities that provide valuable insights into engagement patterns, customer behaviour, and marketing campaign performance. With the analytical and data-driven approach, companies can significantly focus on refining strategies to increase ROI to a great extent.

Customization

When it comes to personalization or setting up preferences, there is no match for enterprise automation which enables businesses to generate highly targeted and personalized content based on customer behavior, preferences, and demographics.

CHAPTER -III

Principles of CRM

***M.N .Kasthuripriya, Department of Management,
Ponnaiyah Ramajayam Institute of Science and Technology(PRIST)***

A customer relationship is a connection between a customer and a company measured in the long-term value of the relationship. To have a successful relationship with a customer, companies must have a strategy in place that encompasses the following four principles:

- Understanding the Customer's Needs
- Listening to What the Customer is Saying
- Understanding the Company's Needs
- Integrating Marketing and Relationship Strategies

Understanding the Customer's Needs

Customer Relationship Management is a win-win process and depends on meeting the company's and the customer's needs. To have a positive relationship with a customer, companies must understand what the customer values in their product or service.

Listening to What the Customer is Saying

Customer Relationship Management is based on two-way communication. Companies must listen to their customers as much as possible. By listening to what the customer says, companies can gain valuable insight into what prospects need, want, and expect from their products and services.

Companies can also gauge how satisfied current customers are with their experience with the company. Listening to what customers are saying can lead to greater awareness of how well your company meets the needs of your target audience. This enables you to improve your product or service offerings and better meet customer needs.

Understanding the Company's Needs

A business's success depends on its ability to manage customer relationships. You can address these issues more effectively when your company has clear objectives and strategies.

So, it will ultimately lead to increased profitability.

For this strategy to be successful, you must understand the needs of your business at all times so you can address these issues effectively. You should also consider any external factors affecting your ability to meet these goals.

Integrating Marketing and Relationship Strategies

For your business to be successful, the way you manage your customers needs to be strategic.

In this sense, the key principle of customer relationship management is integration. You need to integrate marketing and relationship strategies to achieve your business goals and maintain a positive relationship with your customers.

CHAPTER -IV
Software application in CRM.
Mrs. P. Uma Eswari, Department of Management,
Ponnaiyah Ramajayam Institute of Science and Technology(PRIST)

Application 1: Tracking Customers and Contact Management

A good CRM software helps you understand your market and the needs of your customers. As you attract more customers, a CRM makes two things clear: *who* is interested in what you have to offer, and *what* is most important to them.

When it comes to winning more customers, a CRM helps you make smarter decisions than your competition and offer people what they truly want. And if customers leave or your sales stagnate, you can see common threads and change the process accordingly, to better meet their needs and retain them.

Application 2: Collecting Data for Marketing

When you're tangled in spreadsheets and endless email chains, capturing a comprehensive view of vital data on current and future customers becomes a daunting task. Incorporating a CRM system streamlines this process by securely storing crucial data in detailed customer and contact lists. This integration not only simplifies accessing and organizing information but also enhances marketing automation and campaigns.

Application 3: Improving Interactions and Communications

When your list of customers is short, it's easy to keep up with everyone. However, as your business grows and that list becomes longer, it's more likely that sales opportunities and current customers may fall through the cracks. A good CRM helps you maintain great customer relationships with all your clients and let them know what your products and services can do for them.

Application 4: Streamlining Internal Sales Processes

Because every salesperson operates differently, inefficiencies can quickly arise, complicating the sales pipeline and extending the sales cycle. A good CRM system not only helps streamline your internal sales processes for consistency and quality across your sales teams but also aids in keeping track of crucial customer interactions and automate processes. This centralization is the secret to how companies can promise, and consistently deliver, exceptional customer service. Having one repository for all customer information, supported by streamlined processes, ensures that every sales interaction is informed and efficient.

Application 5: Planning Your Operations.

A good customer relationship management tool will help you understand your current capacity and the demand customers are likely to have for your products and services.

This means you will see trends and be informed faster as things grow and change. A CRM helps you know when it's time to hire more people, alter internal processes, or invest resources into more production, before growing pains and panic sets in.

Implementing an operational CRM platform means choosing to break through the ceiling of your sales potential.

CHAPTER -V
Customer Centric Approach
Dr. T. J. Jayasholan, Department of Management,
Ponnaiyah Ramajayam Institute of Science and Technology(PRIST)

1. Empower frontline employees

To ensure that customers receive immediate support and care, it is important to empower frontline employees. This means delegating the necessary power, knowledge, and ability to make the right decisions on time instead of always escalating concerns to the next-level team or manager. To achieve this, companies should provide ways for employees to build customer relationships and interact with them directly at every touchpoint

2. Democratize customer insights

In a customer-centric culture, it is important to share customer insights and sales analytics with employees. By doing so, they can understand their responsibilities and focus better on building rapport and relationships with customers. This is more effective than keeping the data secure in the manager's custody.

To create a customer-centric culture, organizations should regularly discuss and evaluate real-time

3. Implement an eNPS & NPS scoring system

Implementing an eNPS (Employee Net Promoter Score) and NPS (Net Promoter Score) system can help organizations in building a customer-centric culture by:

4. Proactive customer support & customer support tools

By offering proactive support, an organization demonstrates that it values its customers' satisfaction and is committed to addressing their needs and concerns quickly. And when customer support teams have access to the right tools and resources, they can quickly identify and resolve issues before they become major problems. This not only helps your employees to find solutions immediately but also allows them to resolve issues quickly without the need for escalation to higher-level managers.

5. Tie compensation to customer feedback

When compensation is tied to customer feedback, employees become more aware of their impact on customer satisfaction and are incentivized to improve their performance in ways that positively impact the customer experience. Here are some specific ways that tying compensation to customer feedback can help build a customer-centric culture:

6. Delivering real-time customer experience training to staff

Delivering real-time customer experience training to staff provides employees with the knowledge and skills they need to provide exceptional service to customers. When employees understand the importance of providing a positive experience to customers, they are more likely to make an effort to meet their needs and exceed their expectations.

7. Monitoring and evaluating performance at intervals

Set up KPIs to gauge customer-centricity from bottom-level employees to top-level managers to ensure that customer-centricity is a top priority in an organization. This helps to establish a culture that puts the customer first and ensures that everyone in the organization is working towards delivering an exceptional customer experience.

8. Delivering a feeling of value

One of the best practices in creating a customer-centric culture is to make customers feel valued and important. This can be achieved by engaging with them honestly, with integrity, mutual trust, and respect.

CHAPTER -VI
Challenges and Best practices
Dr. K. G. Selvan, Department of Management,
Ponnaiyah Ramajayam Institute of Science and Technology(PRIST)

Navigate change with cohesiveness

- **Change management strategies:** Develop a robust change management plan that includes training programs, workshops, and communication campaigns to help employees understand the benefits of the new technology. Address concerns and demonstrate how the changes align with the organization's goals.
- **Inclusion in decision-making processes:** Involve employees in decisions related to technology implementation to foster a sense of ownership, reduce resistance, and show employees their input is valued.
- **Highlighting success stories:** Share success stories of other organizations or departments implementing similar technologies. This helps build confidence and enthusiasm among employees.

Build resilience into your projects

- **Risk assessment and mitigation:** Conduct a thorough risk assessment at the beginning of the project to identify potential issues. Develop a mitigation plan for each identified risk and regularly revisit and update it throughout the project lifecycle.
- **Agile project management:** Adopt agile project management methodologies to respond to changing circumstances quickly. This allows for regular reassessment of priorities and adaptation to emerging challenges.
- **Continuous improvement:** Establish a culture of constant improvement, where lessons learned from previous implementations are documented and used to enhance future projects. This helps refine processes and avoid similar challenges in subsequent deployments.

Align stakeholders from day one

- **Early and clear communication:** As a technology partner, you should ensure that all the stakeholders are involved from the beginning of the project. Communicating project goals, expectations, and potential benefits brings better alignment and helps avoid disruptive surprises during the project.
- **Regular updates and feedback sessions:** Schedule regular meetings to provide updates on the project's progress. Encourage open communication and stakeholder feedback to address any concerns or misalignments promptly.
- **Documentation of requirements:** Clearly document and validate requirements with all stakeholders. Having a shared understanding of project scope and objectives reduces the chances of misunderstandings.
- **Unified communication:** Implement unified communication tools to streamline information sharing. This can include project management tools, collaborative platforms, and regular status reports to ensure everyone can access relevant information.

CHAPTER -VII
Cost Benefit Analysis of CRM
K.Sasikumar, Department of Management,
Ponnaiyah Ramajayam Institute of Science and Technology(PRIST)

Here are 5 important statistics you should know that indicate that CRM implementation benefits do outweigh the costs. Note that these numbers can act as benchmarks for the CBA for your CRM.

1. According to a Gartner study, the revenue of CRM businesses has increased by 393% between 2010 and 2020. This stark growth in revenue does reflect the benefits that the CRM platforms bring to the table.
2. CRM returns \$3.10 per dollar spent according to a study published by Nucleus Research. This return is mainly for the use cases that help organizations to strengthen customer relationships, leverage enhanced productivity tools, and tap into superior analytics capabilities.
3. According to the 2023 CRM statistics by Tech Report, 91% of companies with 10 or more employees use a CRM, and 92% of businesses say that CRM has helped them achieve their income goals.
4. 46% of customers will buy more when given a personalized experience according to the top customer experience trends in 2024 published by Forbes.
5. Marketing will continue to be the fastest-growing CRM software market with a combined forecast 15.6% CAGR from 2021 through 2026 based on Gartner's Market Opportunity Map report.

Initial Investment

The initial investment in a CRM system includes a license fee for the software purchase or a subscription fee (if the CRM is cloud-based) and implementation costs. Subscription-based cloud CRMs typically have lower upfront costs compared to on-premise solutions.

Ongoing Costs

Ongoing costs include subscription fees for cloud-based systems, maintenance costs for on-premise solutions, and any additional costs for updates, training, managing the CRM, and technical support. Include the on-going costs of buying additional apps for integration with the existing systems.

Hidden Costs

Consider potential hidden costs such as data migration and additional customization. Some customizations can turn out to be costly. So, understanding what customization you'll need with your CRM, is an important step in your CBA.

Analyze Benefits

CRM systems bring different types of benefits in the form of improvements in your processes – both tangible and intangible improvements. Estimate a monetary value for each improvement.

Enhanced Customer Relations

CRM systems offer a 360-degree view of the customer, leading to improved customer service and satisfaction. Ask yourself what will be the monetary value that will be derived once the customer relationships are improved.

CHAPTER -VIII
Introduction to Database Management,
DR. P. Balasubramanian, Department of Management,
Ponnaiyah Ramajayam Institute of Science and Technology(PRIST)

A Database Management System (DBMS) is a software system that is designed to manage and organize data in a structured manner. It allows users to create, modify, and query a database, as well as manage the security and access controls for that database. DBMS provides an environment to store and retrieve data in convenient and efficient manner.

A **database** is a collection of interrelated data that helps in the efficient retrieval, insertion, and deletion of data from the database and organizes the data in the form of tables, views, schemas, reports, etc. For Example, a university database organizes the data about students, faculty, admin staff, etc. which helps in the efficient retrieval, insertion, and deletion of data from it.

Key Features of DBMS

- **Data modeling:** A DBMS provides tools for creating and modifying data models, which define the structure and relationships of the data in a database.
- **Data storage and retrieval:** A DBMS is responsible for storing and retrieving data from the database, and can provide various methods for searching and querying the data.
- **Concurrency control:** A DBMS provides mechanisms for controlling concurrent access to the database, to ensure that multiple users can access the data without conflicting with each other.
- **Data integrity and security:** A DBMS provides tools for enforcing data integrity and security constraints, such as constraints on the values of data and access controls that restrict who can access the data.
- **Backup and recovery:** A DBMS provides mechanisms for backing up and recovering the data in the event of a system failure.
- **DBMS can be classified into two types:** Relational Database Management System (RDBMS) and Non-Relational Database Management System (NoSQL or Non-SQL)
- **RDBMS:** Data is organized in the form of tables and each table has a set of rows and columns. The data are related to each other through primary and foreign keys.
- **NoSQL:** Data is organized in the form of key-value pairs, documents, graphs, or column-based. These are designed to handle large-scale, high-performance scenarios.

CHAPTER -IX
Levels of Data Abstraction,
Dr T J Jayasholan, Department of Management,
Ponnaiyah Ramajayam Institute of Science and Technology(PRIST)

There are mainly 3 levels of data abstraction:

- Physical or Internal Level
- Logical or Conceptual Level
- View or External Level

Physical or Internal Level

This is the lowest level of data abstraction. It tells us how the data is actually stored in memory. Access methods like sequential or random access and file organization methods like B+ trees and hashing are used for the same. Usability, size of memory, and the number of times the records are factors that we need to know while designing the database. Suppose we need to store the details of an employee. Blocks of storage and the amount of memory used for these purposes are kept hidden from the user.

Logical or Conceptual Level

This level comprises the information that is actually stored in the database in the form of tables. It also stores the relationship among the data entities in relatively simple structures. At this level, the information available to the user at the view level is unknown. We can store the various attributes of an employee and relationships, e.g. with the manager can also be stored.

The logical level thus describes the entire database in terms of a small number of relatively simple structures. Although implementation of the simple structures at the logical level may involve complex physical-level structures, the user of the logical level does not need to be aware of this complexity. This is referred to as physical data independence. Database administrators, who must decide what information to keep in the database, use the logical level of abstraction.

View or External Level

This is the highest level of abstraction. Only a part of the actual database is viewed by the users. This level exists to ease the accessibility of the database by an individual user. Users view data in the form of rows and columns. Tables and relations are used to store data. Multiple views of the same database may exist. Users can just view the data and interact with the database, storage and implementation details are hidden from them. Even though the logical level uses simpler structures, complexity remains because of the variety of information stored in a large database. Many users of the database system do not need all this information; instead, they need to access only a part of the database. The view level of abstraction exists to simplify their interaction with the system.

CHAPTER -X
CRM Process in Marketing and Service Organization.
Dr. S. Venkatesh, Department of Management,
Ponnaiyah Ramajayam Institute of Science and Technology(PRIST)

Step 1: Generate brand awareness

The first step to acquiring new customers is awareness, which refers to how familiar prospects and customers are with your brand. Audience response to brand awareness tactics provides clues into what resonates with them. You can collect these clues within a CRM and use them to deliver a personalized customer experience, starting from the very first point of contact.

Step 2: Acquire leads

Introducing your company to potential customers is only the beginning. To start turning awareness into engagement, encourage users to take the next step. When customers interact with your brand, each interaction becomes a source of data that can be stored in a CRM and used to improve touchpoints later. When you build an understanding of customers, you'll be better equipped to meet their expectations and provide superior experiences.

Step 3: Leverage CRM data to convert leads into customers

Once you've successfully engaged potential buyers, it's time to start turning those leads into customers. If leads seem interested but haven't made a purchase, you can leverage engagement data stored in your CRM to provide personalized offers that will help build trust and nurture them toward purchase. You can also apply lead scoring to focus your efforts on the right leads and identify winning opportunities.

Step 4: Build strong customer relationships

The CRM planning process doesn't stop after leads convert to customers. In-depth customer knowledge that supports loyal relationships goes beyond the point of sale to promote ongoing success. By the same measure, your customer relationship management process continues to increase retention by providing personalized experiences that meet and exceed customer expectations.

Step 5: Sell more to your current customers

Past purchase data held in a CRM can help companies identify opportunities to upsell and cross-sell to current customers, either products they've bought before or new products that may be interesting to them, based on previous purchase behavior. By revealing insights like these, a CRM solution can help you provide enticing offers to existing customers, generating a measurable impact on business performance. A data-driven customer relationship management strategy can help you focus on the most valuable prospects, make every customer interaction matter, and grow your business.

SERVICES MARKETING

Edited by

P UMA ESWARI



978-93-6255-892-3

Services Marketing

Copyright © 2023 by P. Uma eswari

All rights reserved. No part of this book may be reproduced or transmitted in any form or by any means without written permission from the author.

ISBN: 978-93-6255-892-3

Publisher: Ponnaiyah Ramajayam Institute of Science and Technology (PRIST)

TABLE OF CONTENTS

| | |
|---|-----|
| CHAPTER-I | 1 |
| Marketing mix in services marketing Dr T J Jayasholan | |
| CHAPTER –II | 09 |
| Product Decisions Dr. S. Venkatesh | |
| CHAPTER –III | 21 |
| Strategies and Tactics Dr K G Selvan | |
| CHAPTER –IV | 36 |
| Additional Dimensions in Services Marketing Dr. S. Venkatesh | |
| CHAPTER -V | 50 |
| Internet as a service channel. K.Sasikumar | |
| CHAPTER -VI | 62 |
| Promotion of Services and Placing Dr K G Selvan | |
| CHAPTER –VII | 73 |
| Distribution Methods for Services Dr T J Jayasholan | |
| CHAPTER -VIII | 83 |
| Strategic Marketing Management for Services K.Sasikumar | |
| CHAPTER -IX | 95 |
| Delivering Quality Services K.Sasikumar | |
| CHAPTER –X | 111 |
| Communication about Service Quality. P. Uma Eswari | |
| REFERENCES | 119 |

CHAPTER -I

Marketing mix in services marketing

***Dr T J Jayasholan , Department of Management,
Ponnaiyah Ramajayam Institute of Science and Technology(PRIST)***

Service marketing is a specialized branch of marketing that promotes and sells services rather than tangible products. It involves strategies to create demand, communicate benefits, and deliver exceptional customer service experiences. Service marketing emphasizes building strong customer relationships by understanding their needs, offering tailored services, ensuring satisfaction, and maintaining engagement to encourage loyalty and repeat business. The goal is to create customer value and ensure a positive and memorable service experience that differentiates the business from competitors.

Example: When marketing its educational services, a tutoring centre emphasizes personalized learning plans, qualified tutors, and success stories of past students. The centre offers free trial classes and showcases positive feedback from satisfied students and parents. The aim is to attract students by demonstrating the value and effectiveness of its tutoring services.

Price

Price involves determining the right amount customers should pay for the service. Various factors like cost, competition, and perceived value are crucial. Pricing strategies, such as discounts, memberships, or packages, can attract different customer segments. The price should reflect the service's value, ensuring it's affordable for customers while generating revenue for the business.

Place:

Place refers to the service's accessibility to customers. It involves choosing the right location and platform to offer the service. For physical locations, convenience, ambience, and facilities matter. For online services, a user-friendly website or app is essential. Ensuring easy access and convenience enhances the customer experience and satisfaction.

Promotion

Promotion involves creating awareness and interest in the service. Effective promotional strategies include advertising, social media marketing, public relations, and sales promotions. Clear, compelling messages communicate the service's benefits, attracting customers and encouraging them to engage with the business. Consistent, targeted promotion increases visibility and builds a strong brand image.

People

People are crucial in service marketing as they directly interact with customers. Employees should be well-trained, professional, and courteous. Excellent customer service creates positive experiences, leading to customer satisfaction and loyalty. Hiring the right people and investing in their training ensures they represent the business positively and meet customers' expectations.

Process

The process involves the procedures, mechanisms, and flow of activities by which the service is delivered. Efficient, customer-friendly processes enhance the service experience, ensuring satisfaction. Streamlining operations, minimizing wait times, and ensuring reliability in service delivery contribute to a positive customer experience and encourage repeat business.

CHAPTER -II
Product Decisions
Dr. S. Venkatesh, Department of Management,
Ponnaiyah Ramajayam Institute of Science and Technology(PRIST)

1. The core benefit of the product. For example:

- Mineral water quenches your thirst.
- Buses take you from point A to B.
- The supermarket allows you to shop for daily groceries.
- Facebook is the platform that keeps you in touch with friends and family.
- StudySmarter helps you ace the exams.

2. The nature of the product and service.

The nature of Starbucks coffee is its ingredients, type of coffee, and cup size.

- The main ingredients are roasted coffee beans, sugar, milk, or cream.
- Types of coffee include blonde roast, medium roast, and dark roast.
- The cup size can be short, tall, or grande.

The nature of the product is what constitutes the product and should be developed according to the customer's needs and wants.

3. Augmented features.

These extra services come with the product, such as guarantee, installation, customer support, and maintenance. Besides product quality, augmented features play an essential role in turning a new customer into a regular one.

Product Attribute Decisions

One of the primary decisions marketers have to make involves decisions about product attributes. Product attributes are the characteristics and defining features of a product. They are individual product decisions and are as follows:

- **Product quality decisions** - The quality of a product is crucial for its marketing. It plays a key role in positioning as products can be positioned based on their high quality (e.g., high-performance luxury cars or high fashion clothing made from the best quality fabrics). Product quality is also essential for providing value to customers - a high-quality product can be a value-adding feature that results in customer satisfaction.
- **Product feature decisions** - Another element of product attributes are the product's features. Product features are crucial for differentiation. Adding additional features makes a product stand out from similar products offered by competitors. So, how do marketers know which product features to add? Through market research. Of course, adding a random product feature will not automatically guarantee success.
- **Product design decisions** - Similarly to product features, product design can help marketers differentiate their offerings from competitors. For example, a functional design can make it easier for customers to use a product, leading to fewer complaints, returns, etc. On the other hand, product style can capture customers' attention.

CHAPTER -III
Strategies and Tactics
Dr K G Selvan, Department of Management,
Ponnaiyah Ramajayam Institute of Science and Technology(PRIST)

Data-informed decisions

A good strategy is well thought out, planned, and extremely well researched. If you're looking to build a strong, long-term strategy, it's important to gather information and data from past experiences to influence your future data-driven decision making process. For example, some industries experience seasonality with their business. Knowing how to use that seasonality to your advantage is an example of good strategic thinking and using historical data to your benefit.

Clearly defined goals

The best strategies are built around clearly defined goals. It's much easier to build a good strategy when you know exactly what you need to achieve. Having clearly defined goals is a key part of the overall planning process for long-term strategy. Some people plan both their strategy and their business goals at the same time, which can streamline the process. But if there's no end goal, trying to create your strategy is like trying to run a race without knowing the route.

Read: Setting business goals: The first step to a successful business

Contingency plans

The success of your strategy is contingent on an expected outcome, but what happens when your strategy gets derailed? This is where a contingency plan comes in. If you build a contingency plan into your strategy, then you can plan for speed bumps. Your team will know what to do to get over the speed bump to prevent the project from getting completely derailed.

Tactics are short term

If the strategy is the long-term plan, tactics are the short-term steps that help you hit smaller goals. Tactical planning is the act of breaking down your strategic plan into short-term actions.

Tactics are clearly tied to strategy

If you're struggling to understand how a specific tactic contributes to your strategy, it might not be the best tactic for your strategy. The work you do should actively contribute to the goals that you want to achieve.

The goal-setting framework OKRs is a good example of how short-term tactics connect to a long-term vision.

CHAPTER -IV

Additional Dimensions in Services Marketing

Dr. S. Venkatesh, Department of Management,

Ponnaiyah Ramajayam Institute of Science and Technology(PRIST)

1. Tangibility

Tangibility is the appearance of physical facilities, equipment, personnel, and communication materials. Customers expect clean and professional facilities and shops, employees who look groomed and neat, and well-written and designed materials such as menus, websites, and signs. Attention to appearance can indicate that your company takes customer comfort seriously.

2. Reliability

Reliability is the ability to perform the promised service dependably and accurately. Doing what you say you're going to do when you say you're going to do it is essential to pleasing your customers. They want to rely on your business to deliver a working product or effective service, get help when needed, and for all of this to happen in a timely fashion.

3. Responsiveness

Responsiveness is the willingness to help customers and provide prompt service; it lets your customers know you're listening to them and working actively to solve their problems.

Responding quickly to customer questions and concerns is vital, especially in today's fast-paced world—especially when 80% of consumers expect a response to customer service requests within one business day. Responsiveness even applies when customers are slow in responding to you. Answer swiftly to let customers know that you're working on their request.

4. Assurance

Assurance is employees' knowledge and ability to convey trust and confidence. Customers expect businesses to be the experts in the service they deliver. Communicating that expertise to customers helps reassure them that they can trust you, whether you accomplish this by displaying credentials and industry certifications or customer testimonials.

5. Empathy

Empathy is the caring, individualized attention the firm provides its customers.

Customers want to feel like they're more than a transaction; they want to build a relationship with your business. Even if you have the best product or services, you can still fall short of their expectations.

Showing empathy to customers means ensuring your company showcases your care. Training employees on providing excellent and empathetic service—where smiles and engaging conversation occur regularly—can help you exceed expectations.

CHAPTER -V

Internet as a service channel.

K.Sasikumar, Department of Management,

Ponnaiyah Ramajayam Institute of Science and Technology(PRIST)

Live chat support team

It produces higher customer fulfillment levels, and around 80% of customers lean toward this service channel in light of the immediacy it gives. Businesses that use it can comprehend customer needs and adjust their services on the go. Its real-time interaction with the customers develops brand loyalty as well as increments customer lifetime value.

Email

Email is a useful, low-cost service channel of customer support for most organizations to give a superior customer experience. More than 60% of customers say that email support is their favored method for speaking with brands. For online organizations, email customer service is one of the inevitable channels.

Chatbots

Many modern businesses significantly depend on AI for robotizing customer services. It enables them to give better brief help at different touchpoints of the customer journey. Utilizing a chatbot alongside other channels in business can assist with offering instant help to the FAQs mentioned by customers.

it ensures real-time engagement that optimizes the fulfillment rate of users. Subsequently, a chatbot conveys an effective customer service experience. In case your business gets repetitive inquiries, executing chatbots can be a savvy method for offering immediate help without making customers stand by. These can be utilized as the primary touchpoint to decrease customer churn rate.

Video Chat support teams

It is one of the latest and broadly embraced channels used by businesses to optimize their customer service standards. It also improves customer experiences. It makes customer interactions more interactive, intelligent and customized and hence it conveys a superior experience. It takes the customer fulfillment levels to 73% which is the top-most level for any customer service channel.

Messaging applications

Messaging apps have also become inevitable for effective digital customer service as more than 2 billion active users a month use WhatsApp and Facebook Messenger which has shown that the modern buyers favor using messaging apps over other customer service channels. These applications have now turned into a necessary piece of customer service worldwide.

Social Media Platforms

Nowadays, social media platforms are the critical parts of effective customer service. The shared advantages of powerful brand availability through Facebook, Twitter, LinkedIn, Messenger, YouTube, and others let brands interact and engage their customers in a result-driven as well as real-time manner. It also helps brands in boosting their brand-building exercises.

CHAPTER -VI

Promotion of Services and Placing

Dr K G Selvan, Department of Management,

Ponnaiyah Ramajayam Institute of Science and Technology(PRIST)

Digital Marketing

Digital marketing is any promotion found on the internet. This online advertising may be in the form of SEO, content marketing, PPC, social media marketing, affiliate marketing, etc. It comes through some of the following channels – websites, email, social media, search engines, and mobile apps. Digital marketing is less expensive and faster to develop than the other forms, but it can take a little longer to show impact. Consumers rely on digital marketing to be kept up to date on the latest goods and services available to them from brands they trust and to research potential purchases.

Google's marketing insights tell us that 48% of people begin their product inquiries on search engines, with 33% visiting brand websites, and 26% searching on mobile apps.

Personal Selling

This is the oldest form of selling and promotion. It usually takes place one on one – over the phone or in person. An example of this is door-to-door sales or cold calling consumers to persuade them to make a purchase or place an order.

The method seems ancient, but it has its advantages. The message is customized to the target audience, and the message is directly received. If there are questions or misunderstandings, they can be cleared up immediately. And the salesperson can tailor their approach to the individual with whom they are speaking.

The disadvantages are obvious. It is a lot of work and time to reach only one person or household. Additionally, the salesperson may be aggressive, condescending, or just plain annoying, leading to no sale and a disheartened prospect.

Direct Marketing

Direct marketing is sending mail, email, or other media directly to the target consumer. Direct mail is the most popular form of direct marketing and is the cheapest. Like personal selling, a message can be tailored and made quite specific for the prospective client. Campaigns can be quickly put together along with offers, discounts, or even product research. The mail is sent only to prospects who are likely to purchase or participate, rather than a broad-scale mailing. Unfortunately, unsolicited mail is often viewed as 'junk mail' and discarded – at times, rendering this method unprofitable.

Related: 25 Product Launch Strategies (and Steps) for a Flawless Launch

Public Relations

Public relations as a marketing tool works wonders. It's the method of using mostly free means to inform potential customers and clients of your company, products, or services. It's inexpensive but effective to send out press releases about new products or services. People trust newspapers, so not only does this lend credibility to your story, but it is also at no cost to you.

CHAPTER -VII
Distribution Methods for Services
Dr T J Jayasholan, Department of Management,
Ponnaiyah Ramajayam Institute of Science and Technology(PRIST)

Direct

A direct channel allows the consumer to make purchases from the manufacturer. This direct (and short) channel may mean lower costs for consumers because they are buying directly from the manufacturer.

Indirect

An indirect channel allows the consumer to buy the goods from a wholesaler or retailer. Indirect channels are typical for goods that are sold in traditional brick-and-mortar stores.

Hybrid

Hybrid distribution channels use both direct channels and indirect channels. A product or service manufacturer may use a retailer to distribute a product or service, in addition to also making sales directly with the consumer.

Distribution Channel Levels

Level

This is a direct-to-consumer model, where the producer sells its product directly to the end consumer. Amazon, which uses its sales platform to sell its Kindle product to customers, is an example of a Level 0 (direct) model. This is the shortest distribution channel possible, cutting out both the wholesaler and the retailer.

Level 1

A producer sells directly to a retailer, who then sells the product to the end consumer. This level includes only one intermediary. For example, Hewlett-Packard and Dell are large enough to sell their computer products directly to retailers, including Best Buy.

Level 2

Including two intermediaries, this level includes the producer, wholesaler, retailer, and consumer. In the wine and adult beverage industry, a winery cannot sell directly to a retailer. A winery must utilize a multi-tiered system, like a Level 2 system; the law requires the winery to first sell its product to a wholesaler, who then sells to a retailer. The retailer then sells the product to the end consumer.

Level 3

This level may add the role of the individual, sometimes referred to as a "jobber." A jobber is a small-scale wholesaler or middleman in the retail goods trade. This role may involve assembling products from a variety of producers, storing them, selling them to retailers, and acting as a middle-man for wholesalers and retailers.

CHAPTER -VIII

Strategic Marketing Management for Services

K.Sasikumar, Department of Management,

Ponnaiyah Ramajayam Institute of Science and Technology(PRIST)

1. Conduct a marketing audit

Before thinking about what might work in the future, it's important to look to the past. Go back as far as is practical and do a marketing audit, that is to compile a list of all marketing activations along with their results. This will help you fine-tune your strategic marketing plan.

2. Collect market research

The next step is to clearly understand where your business stands in the marketplace. This will help give you a sense of strategic direction, and it's best discovered by conducting market research with your target users or customers.

3. Understand your audience

Now that you have the results of your market research, your next step is to define exactly who you'll be targeting with your strategic marketing plan. This may be a specific demographic, socioeconomic group, age, gender, and so on.

4. Develop your positioning and messaging

Marketing campaigns live and die on messaging. At this point in strategy development, clarify and document precisely what you want your brand position to be and how you want customers to see you in the market.

5. Set company and marketing goals

One of the primary goals of strategic marketing is to align your efforts with your overall company goals and objectives — and now's the time to do it.

6. Determine your budget

Money talks, especially when it comes to the reach of your marketing campaigns. Decide exactly what you want to spend *now*, and you won't end up blowing your budget further down the road.

7. Develop marketing campaigns

Next, it's time to get practical. Begin to develop specific marketing campaigns based on the channels you're most likely to reach your target customer.

8. Develop an implementation timeline

Timing is everything, so set specific flight dates for your campaigns before they go live. This will also help when it comes to assessing outcomes.

9. Evaluate and make improvements

The final step in developing a strategic marketing plan is to review the results of your campaigns to see what worked (or what didn't) so that you can make changes next time.

CHAPTER -IX

Delivering Quality Services

K.Sasikumar, Department of Management,

Ponnaiyah Ramajayam Institute of Science and Technology(PRIST)

Many people are familiar with the phrase, "Lead, follow or get out of the way." It is time for us to start making organizational decisions based upon that phrase, or we are going to fail. Those organizations that do things a year--or more--after others have done them might feel like they're constantly playing catch-up to the leaders, but that's better than nothing. Getting out of the way is for those who can't keep up. They're bound to fail and we can no longer support failure.

Today, our customers are more knowledgeable and demanding than ever; they know what they want and how they want it delivered. They're quick to criticize poor performance and will use the ballot box to show their displeasure. Meanwhile, public funding is getting tougher to obtain and many organizations have resorted to billing for services to supplement dwindling funds. It's only going to get harder, and it's our obligation to become the public service that is recognized for meeting the goals and expectations of those customers, the public.

Defining Quality Service

- Quality is the highest level of care that can be provided to customers within the scope of the organization.
- Quality management is a process of continuous improvement through which everyone strives to create and support an environment in which people are committed to serving and meeting the needs of customers.
- Quality is conformance to standards that meet or exceed customer expectations.
- Quality is being the best individual you can be within a departmental structure.

Requiring Quality from Start to Finish

Implementing quality customer services takes more than just snapping your fingers.

- Hiring standards. Hire only people who fully understand that yours is an organization dedicated to the highest standards in delivering quality services to customers.
- Employee orientation. Educate every employee as to your standards and how you measure success. Each individual must understand he is accountable for meeting every standard of quality.
- Job requirements. Establish quality as a requirement of the job. To keep their positions, employees must understand, stand by and--most important--practice at the highest level of quality service.
- Evaluation process. Employee evaluations must include a component identifying individual success in following the organization's standards of quality.
- Rewards. Reward employees when they accomplish customer service goals.

CHAPTER -X

Communication about Service Quality.

P. Uma Eswari, Department of Management,

Ponnaiyah Ramajayam Institute of Science and Technology(PRIST)

(1) Convenience

Giving your customers the freedom to choose their preferred communication channel is part of providing an excellent customer experience. Be present on the channels your customers use the most to ensure quick resolutions to customer questions. For example, if your customers belong to a younger demographic, you might want to consider offering customer support through your social media and mobile-first messaging channels such as WhatsApp and LINE. According to Microsoft research, 54% of consumers worldwide favor brands that respond to customer service questions or complaints on social media.

(2) Personalization

While scripts help your customer service team with general direction, personalizing communication is what great customer service is about. If your customer service representatives can relate to the customers' needs, they will feel heard from the beginning. When customers contact customer support, they are looking for someone who can understand their issue and help with a quick resolution.

Let's assume your company sells luxury products, you'd want your reps to treat customers like VIPs. You can do this by viewing previous customer service interactions across channels and accessing their order history to learn about the customer's issue.

By gathering context beforehand, you can give the customer the impression that you know exactly what they are going to talk about. This can help you offer fast, context-rich, personalized assistance that is nothing short of VIP treatment, which will ultimately lead to increased customer satisfaction.

(3) Consistency

Excellent customer service communication is consistent across channels and customer interactions. It means that the service experience doesn't change depending on who offers support. For example, when customer support reps communicate with your customers, you want them to use consistent tone and language and refer to unified customer records to ensure that customers don't experience any friction in their experience.

It's best to ensure that your brand voice shines through in all interactions. Brands also need to be consistent in the vocabulary they use across all channels, and reps should have the skills to use it precisely during interactions.

(4) Feedback responses

Each interaction with your customer is an opportunity to collect valuable data about how your customers feel about your brand. According to Microsoft, 89% of customers view brands favorably if they proactively invite and welcome customer feedback [2]. You can use the given information to learn more about your customers' likes and dislikes, consider improving your product, and tailor more effective communication. Additionally, collecting customer feedback tells your customers that you care, helping you strengthen relationships.

MODERN CRYPTOGRAPHY

EDITED BY
S . GAYATHRI



978-93-6255-934-0

MODERNCRYPTOGRAPHY

Copyright © 2023 by S.GAYATHRI

All rights reserved. No part of this book may be reproduced or transmitted in any form or by any means without written permission from the author.

ISBN: 978-93-6255-934-0

Publisher: PonnaiyahRamajayam Institute of Science and Technology (PRIST)

TABLEOF CONTENTS

| | | | |
|---------------------|------------------------------|---|------------|
| Introduction | | - | 03 |
| CHAPTER 1 – | Formal Notions Of Attacks | - | 15 |
| Dr. R.Latha | | | |
| CHAPTER 2 – | Random Oracles | - | 40 |
| Ms.S.Gayathiri | | | |
| CHAPTER 3 – | Building a Pseudorandom | - | 73 |
| Dr. R.Latha | | | |
| CHAPTER 4 – | Permutation | - | 120 |
| Ms.M.Jeeva | | | |
| CHAPTER 5 – | Message Authentication Codes | - | 140 |
| Ms.S.Gayathiri | | | |
| CHAPTER 6 – | Symmetric Key Cryptography | - | 156 |
| Dr. R.Latha | | | |
| CHAPTER 7 – | Asymmetric-Key Cryptograpghy | - | 173 |
| Ms.S.Gayathiri | | | |
| CHAPTER 8 – | Homomorphic encryption | - | 183 |
| Dr. R.Latha | | | |
| CHAPTER 9– | Multi-Party Computation | - | 210 |
| Ms.M.Jeeva | | | |
| CHAPTER 10 – | Cryptographic Voting Systems | - | 240 |
| Ms.S.Gayathiri | | | |
| REFERENCES | | - | 254 |

CHAPTER 1

Formal Notions of Attacks

Dr. R.Latha

Formal notions of attacks are key in understanding security and adversarial threats in various fields such as computer science, information security, and network security. Here's a summary of some key concepts and terms.

Introduction

1. Attack Definition

- **Attack:** An attempt to exploit vulnerabilities in a system, aiming to disrupt, damage, or gain unauthorized access to a resource.
- **Adversary:** An entity that performs attacks. This could be an individual, group, or automated system.

2. Types of Attacks

- **Passive Attacks:** Aim to gather information without altering the system. Example: Eavesdropping.
- **Active Attacks:** Involve modification of data or system behavior. Example: Data modification, denial of service.

3. Attack Models

- **Intrusion Model:** Focuses on unauthorized access to a system. Common in network security.
- **Threat Model:** Defines possible threats and vulnerabilities within a system. Includes threat agents and their capabilities.

4. Attack Vectors

- **Physical Attacks:** Direct physical interaction with the system (e.g., hardware tampering).
- **Network Attacks:** Exploiting vulnerabilities in network protocols or configurations (e.g., man-in-the-middle attacks).

5. Security Goals

- **Confidentiality:** Ensuring that information is not disclosed to unauthorized individuals.
- **Integrity:** Ensuring that information is not altered by unauthorized individuals.

These formal notions provide a structured approach to understanding and mitigating various forms of attacks, ensuring comprehensive security management.

CHAPTER 2

Random Oracles

Ms.S.Gayathiri

Random Oracle Model (ROM) A theoretical framework used in cryptography where a random oracle is an idealized, hypothetical black box that provides truly random responses to each unique query. To analyze and prove the security of cryptographic algorithms and protocols in a simplified, idealized setting.

Characteristics of Random Oracles:

- **Ideal Randomness:** The oracle provides a completely random and independent response for each unique input.
- **Uniform Distribution:** Responses are uniformly distributed over the possible output space.
- **Query Independence:** Responses to different queries are independent of each other.

Applications in Cryptography:

- **Hash Functions:** Often used to model ideal cryptographic hash functions. In the random oracle model, hash functions are assumed to behave like random oracles.
- **Security Proofs:** Many cryptographic constructions, such as secure encryption schemes and digital signatures, are analyzed under the random oracle model to provide proofs of security.
- **Protocols:** Used to demonstrate the security of protocols by showing that they are secure when the hash function acts as a random oracle.

Advantages:

- **Simplified Analysis:** Allows for more straightforward proofs of security by providing a clear and idealized model.
- **Benchmark:** Provides a benchmark for understanding the security of cryptographic primitives and protocols in an idealized setting.

Conclusion:

- **Theoretical Tool:** Random oracles are a valuable theoretical tool for proving the security of cryptographic schemes.
- **Practical Considerations:** While useful for initial proofs and analysis, the transition from random oracle-based proofs to practical implementations requires careful consideration of real-world hash functions and their properties.
- Understanding random oracles and their role in cryptographic proofs helps in designing and analyzing secure systems, while also acknowledging the limitations when moving from theoretical models to practical applications.

CHAPTER 3

Building a Pseudorandom

Dr. R.Latha

Pseudorandom Number Generator (PRNG): An algorithm that generates a sequence of numbers that approximates the properties of random numbers. Unlike true randomness, the output is deterministic and reproducible from a given initial state or seed.

Key Properties:

- **Periodicity:** The sequence will eventually repeat after a certain number of outputs. A good PRNG has a long period before repetition.
- **Uniform Distribution:** The numbers should be uniformly distributed across the possible range.

Components of PRNG:

- **Seed:** The initial value that starts the PRNG. It should be chosen to be as unpredictable as possible to ensure the sequence starts in a non-deterministic state.
- **Algorithm:** The core function that generates the sequence of numbers from the seed. Common algorithms include Linear Congruential Generators (LCGs), Mersenne Twister, and Cryptographically Secure PRNGs.

Common PRNG Algorithms:

- **Linear Congruential Generator (LCG):**
 - Formula: $X_{n+1} = (aX_n + c) \bmod m$
 - Where a , c , and m are constants.
 - Simple and fast but can have short periods and poor randomness if parameters are not well-chosen.
- **Mersenne Twister:**
 - A widely used PRNG known for its long period ($2^{19937}-1$) and high-quality randomness.
 - Based on a matrix linear recurrence.
- **Cryptographically Secure PRNGs (CSPRNGs):**
 - Designed to be secure against cryptographic attacks.

Security Considerations:

- **Seed Security:** Protect the seed from exposure to ensure the unpredictability of the PRNG.
- **Algorithm Strength:** Use well-vetted and tested algorithms, especially in security-sensitive applications.

CHAPTER 4

Permutation

Mr.D.Hariharan

Permutation: An arrangement or rearrangement of the elements in a set. It refers to a specific order in which the elements are arranged.

Types of Permutations:

- **Simple Permutation:** The arrangement of all elements in a set. For a set with n elements, the number of possible permutations is $n!$ (factorial of n).
- **Partial Permutation:** Arrangements of a subset of the elements. The number of partial permutations of k elements from a set of n elements is given by $P(n,k) = \frac{n!}{(n-k)!}$.

Notation:

- **Factorial Notation:** $n!$ (n factorial) represents the product of all positive integers up to n . $n! = n \times (n-1) \times (n-2) \times \dots \times 1$
- **Permutation Notation:** $P(n,k)$ represents the number of ways to arrange k elements from n elements.

Example:

- **Full Permutations:** For a set of 3 elements $\{A, B, C\}$, the permutations are: $\{A, B, C\}, \{A, C, B\}, \{B, A, C\}, \{B, C, A\}, \{C, A, B\}, \{C, B, A\}$. Total: $3! = 6$ permutations.

Permutations with Constraints:

- **Restricted Permutations:** Permutations with certain constraints or conditions, such as permutations avoiding certain fixed points or patterns.
- **Derangements:** Permutations where no element appears in its original position.

Algorithms and Techniques:

- **Generating Permutations:** Algorithms to generate permutations include:
 - **Backtracking:** A method to explore all possible permutations by building them step-by-step.
 - **Heap's Algorithm:** Efficient for generating all permutations of n elements.
 - **Steinhaus-Johnson-Trotter Algorithm:** Generates permutations in a specific sequence known as the "gray code" for permutations.

CHAPTER 5

Message Authentication Codes

Ms.S.Gayathiri

Message Authentication Code (MAC): A cryptographic technique used to verify the integrity and authenticity of a message. A MAC ensures that a message has not been altered and that it comes from a legitimate sender.

Purpose:

- **Data Integrity:** Ensures that the message has not been tampered with during transmission.
- **Authenticity:** Confirms that the message was generated by a legitimate sender who possesses a shared secret key.

Basic Components:

- **Message:** The data or content to be authenticated.
- **Key:** A secret key shared between the sender and the receiver. This key is used to generate and verify the MAC.
- **MAC Algorithm:** A cryptographic function that combines the message and the key to produce a MAC value.

Common MAC Algorithms:

- **HMAC (Hash-based Message Authentication Code):**
 - Uses a cryptographic hash function (e.g., SHA-256) along with a secret key.
 - Formula: $MAC = \text{HMAC}_{key}(\text{message})$
 - Provides both data integrity and authenticity.
- **CMAC (Cipher-based Message Authentication Code):**
 - Uses a block cipher (e.g., AES) in a specific mode (usually CMAC mode).
 - Formula: $MAC = \text{CMAC}_{key}(\text{message})$
 - Provides similar security properties as HMAC but relies on block ciphers..

Algorithms and Techniques:

- **Generating Permutations:** Algorithms to generate permutations include:
 - **Backtracking:** A method to explore all possible permutations by building them step-by-step.
 - **Heap's Algorithm:** Efficient for generating all permutations of nnn elements.
 - **Steinhaus-Johnson-Trotter Algorithm:** Generates permutations in a specific sequence known as the "gray code" for permutations.

CHAPTER 6

Symmetric Key Cryptography

Dr. R.Latha

Symmetric key cryptography is a method of encryption where the same key is used for both encrypting and decrypting data. This type of cryptography relies on a shared secret between the sender and receiver to secure the communication. Because only one key is used, symmetric key cryptography is often faster and more efficient than asymmetric cryptography, making it suitable for encrypting large amounts of data.

Key Features:

1. **Single Key:** The same key is used for both encryption and decryption.
2. **Speed:** Generally faster and more efficient for bulk encryption compared to asymmetric key cryptography.
3. **Security:** The strength of symmetric encryption depends heavily on the secrecy of the shared key. If the key is compromised, so is the data.
4. **Common Algorithms:** Some widely used symmetric key algorithms include:
 - **AES (Advanced Encryption Standard):** Known for its strong security and performance.
 - **DES (Data Encryption Standard):** An older standard that has largely been replaced by AES due to vulnerabilities.
 - **3DES (Triple DES):** A modification of DES that applies the encryption three times for added security.
 - **Blowfish: A fast and flexible block cipher.**

How It Works:

- **Encryption:** The plaintext (data) is combined with the encryption key using an algorithm to generate ciphertext (encrypted data).
- **Decryption:** The ciphertext is combined with the same key using a decryption algorithm to recover the original plaintext.

Use Cases:

- **Data at Rest:** Encrypting files, databases, or storage devices.
- **Data in Transit:** Securing communication over networks (e.g., VPNs, secure emails).
- **Real-time Systems:** High-speed systems where efficiency is crucial, like voice or video encryption.

Drawbacks:

- **Key Distribution Problem:** Securely sharing the secret key between parties can be challenging, especially in large systems.
- **Scalability:** For large networks, symmetric key cryptography requires a separate key for each pair of users, leading to complex key management.

CHAPTER 7

Asymmetric-Key Cryptography

Ms.S.Gayathiri

Asymmetric key cryptography, also known as public-key cryptography, is an encryption method that uses a pair of keys: one public and one private. The public key is shared openly and used to encrypt data, while the private key is kept secret and used to decrypt the data. This dual-key system overcomes the key distribution issues associated with symmetric key cryptography.

Key Features:

1. **Key Pair:** It uses two mathematically related keys—a **public key** and a **private key**.
 - **Public Key:** Can be shared with anyone. Used for encryption or verifying a digital signature.
 - **Private Key:** Kept secret by the owner. Used for decryption or creating a digital signature.
2. **Security:** The strength lies in the difficulty of deriving the private key from the public key (e.g., through complex mathematical problems like factoring large prime numbers).
3. **Slower:** Asymmetric encryption is computationally more intensive and slower compared to symmetric key cryptography, which is why it's often used in combination with symmetric methods for efficiency.
4. **Common Algorithms:** Some popular asymmetric key algorithms include:
 - **RSA (Rivest–Shamir–Adleman):** One of the earliest and most widely used public-key algorithms, relying on the difficulty of factoring large prime numbers.
 - **ECC (Elliptic Curve Cryptography):** Offers stronger security with smaller key sizes compared to RSA, making it more efficient.
 - **DSA (Digital Signature Algorithm):** Primarily used for digital signatures rather than encryption.

How It Works:

- **Encryption:** Data is encrypted using the recipient's public key, ensuring that only the holder of the corresponding private key (the recipient) can decrypt it.
- **Decryption:** The recipient uses their private key to decrypt the data.
- **Digital Signatures:** The sender can sign a message with their private key, and the recipient can verify the signature using the sender's public key, ensuring the message's authenticity.

Use Cases:

- **Secure Communication:** Enabling secure data transmission without the need to pre-share a key (e.g., HTTPS, email encryption).
- **Digital Signatures:** Verifying the authenticity and integrity of digital messages or documents.
- **Key Exchange:** Used to securely exchange symmetric keys.

CHAPTER 8

Homomorphic encryption

Dr. R.Latha

Homomorphic encryption is a type of encryption that allows computations to be performed directly on encrypted data without requiring access to the plaintext. The result of these computations, when decrypted, matches what would have been obtained if the same operations were performed on the plaintext data. This property is useful for secure data processing, enabling privacy-preserving computations in scenarios like cloud computing and data analysis.

Key Features:

1. **Computation on Encrypted Data:** The primary feature of homomorphic encryption is that it enables computations (like addition or multiplication) on ciphertexts.
2. **Privacy Preservation:** Since the data remains encrypted during computation, it ensures privacy and confidentiality. Neither the entity performing the computation nor third parties can access the original data.
3. **Encryption Schemes:** There are different types of homomorphic encryption schemes based on the type and complexity of operations they allow:
 - **Partially Homomorphic Encryption (PHE):** Supports only one type of operation (e.g., addition or multiplication).
 - **Somewhat Homomorphic Encryption (SHE):** Allows a limited number of operations, usually a combination of addition and multiplication, but with certain restrictions.
 - **Fully Homomorphic Encryption (FHE):** Allows arbitrary computations, including both addition and multiplication, on encrypted data without limitations.

How It Works:

- **Encryption:** Data is encrypted using a homomorphic encryption algorithm. The ciphertext allows certain operations to be performed without decrypting the data.
- **Computation:** Operations like addition, multiplication, or other mathematical functions are performed on the ciphertext. The result remains encrypted.
- **Decryption:** After the computations are done, the encrypted result can be decrypted by the data owner, revealing the correct result of the operation as if it were performed on the plaintext.

Use Cases:

1. **Cloud Computing:** Users can upload encrypted data to the cloud, and cloud service providers can perform computations on the data without ever seeing the unencrypted information. This is useful in industries like finance, healthcare, or government, where data privacy is critical.
2. **Secure Data Analysis:** Researchers can perform statistical analysis on encrypted datasets (e.g., medical or genomic data) while preserving the privacy of individuals.
3. **Encrypted Machine Learning:** Homomorphic encryption enables training and inference of machine learning models on encrypted data, allowing privacy-preserving AI applications.

CHAPTER 9

Multi-Party Computation

Ms.M.Jeeva

Multi-Party Computation (MPC) is a cryptographic technique that allows multiple parties to collaboratively compute a function over their inputs while keeping those inputs private. In an MPC protocol, each party knows only their own input, and no one else learns anything about the other parties' inputs except for the final result of the computation.

Key Features:

1. **Privacy:** MPC ensures that the inputs of the parties remain confidential throughout the computation process. Only the final output of the computation is revealed, and no one learns anything else about others' inputs.
2. **Collaborative Computation:** The parties work together to compute a function (e.g., sum, average, or more complex operations) without revealing their individual data.
3. **Secure Against Adversaries:** MPC is designed to be secure even in the presence of malicious or semi-honest parties who might try to learn more than they should.
4. **No Trusted Third Party:** MPC eliminates the need for a trusted central authority to perform the computation, ensuring decentralization and trust minimization.

How It Works:

In a typical MPC protocol, each party splits their input into secret "shares" and distributes these shares to the other parties. These shares are structured in such a way that no single share reveals any information about the original input. The computation is then performed on these shares in a distributed manner, and at the end of the protocol, the parties can jointly reconstruct the final result without revealing individual inputs.

Key Steps:

1. **Input Sharing:** Each party splits its private input into multiple shares and distributes these shares to all other parties.
2. **Computation on Shares:** The parties perform the computation using these shares without reconstructing the original inputs.
3. **Reconstruction of Output:** Once the computation is completed, the shares of the result are combined to reveal the final output.

Types of Adversaries in MPC:

- **Semi-honest (Passive) Adversary:** A party that follows the protocol correctly but tries to learn additional information from the messages it receives.
- **Malicious (Active) Adversary:** A party that can deviate from the protocol in any way to disrupt the computation or extract additional information.

CHAPTER 10

Cryptographic Voting Systems

Ms.S.Gayathiri

Cryptographic voting systems use cryptographic techniques to ensure the security, privacy, and integrity of electronic voting. These systems aim to provide the same trustworthiness as traditional voting while leveraging the benefits of digital technology, such as convenience, efficiency, and scalability. Cryptography is used to secure voter privacy, prevent fraud, and ensure that votes are counted correctly, even in environments where some participants may be untrusted.

Key Features of Cryptographic Voting Systems:

1. **Voter Privacy:** Ensures that no one, including election officials, can determine how an individual voted.
2. **Verifiability:**
 - **Individual Verifiability:** Voters can verify that their vote was cast and included in the tally without revealing their choice.
 - **Universal Verifiability:** Anyone can verify that the election outcome is accurate and that all votes were counted correctly.
3. **Integrity:** Ensures that votes cannot be altered, added, or removed without detection.
4. **Coercion Resistance:** Prevents voters from being forced to vote in a certain way, even if they want to prove how they voted.
5. **Transparency:** Ensures that the election process is transparent, while still maintaining voter privacy.

Cryptographic Techniques Used:

1. **Homomorphic Encryption:** Allows operations (e.g., tallying votes) to be performed on encrypted votes without decrypting them, preserving voter privacy while ensuring the integrity of the result.
2. **Zero-Knowledge Proofs:** Used to prove that a voter's vote was correctly included in the tally without revealing how the vote was cast. This provides verifiability without compromising privacy.
3. **Mix Networks (Mixnets):** A series of servers shuffle and re-encrypt votes in such a way that the link between a voter and their vote is obfuscated, ensuring anonymity.
4. **Blind Signatures:** Allows voters to receive a signed voting token from an authority without the authority knowing what the token represents. This ensures privacy while still enabling authentication.

Digital Signatures Used for voter authentication and to ensure the integrity of transmitted votes, confirming that a vote comes from a legitimate voter and has not been tampered with.

Secret Sharing: In some systems, the ability to decrypt the vote tally is distributed among multiple authorities to prevent any single authority from decrypting individual votes.

SOCIAL NETWORK SECURITY

EDITED BY
Dr.L.S.USHARANI

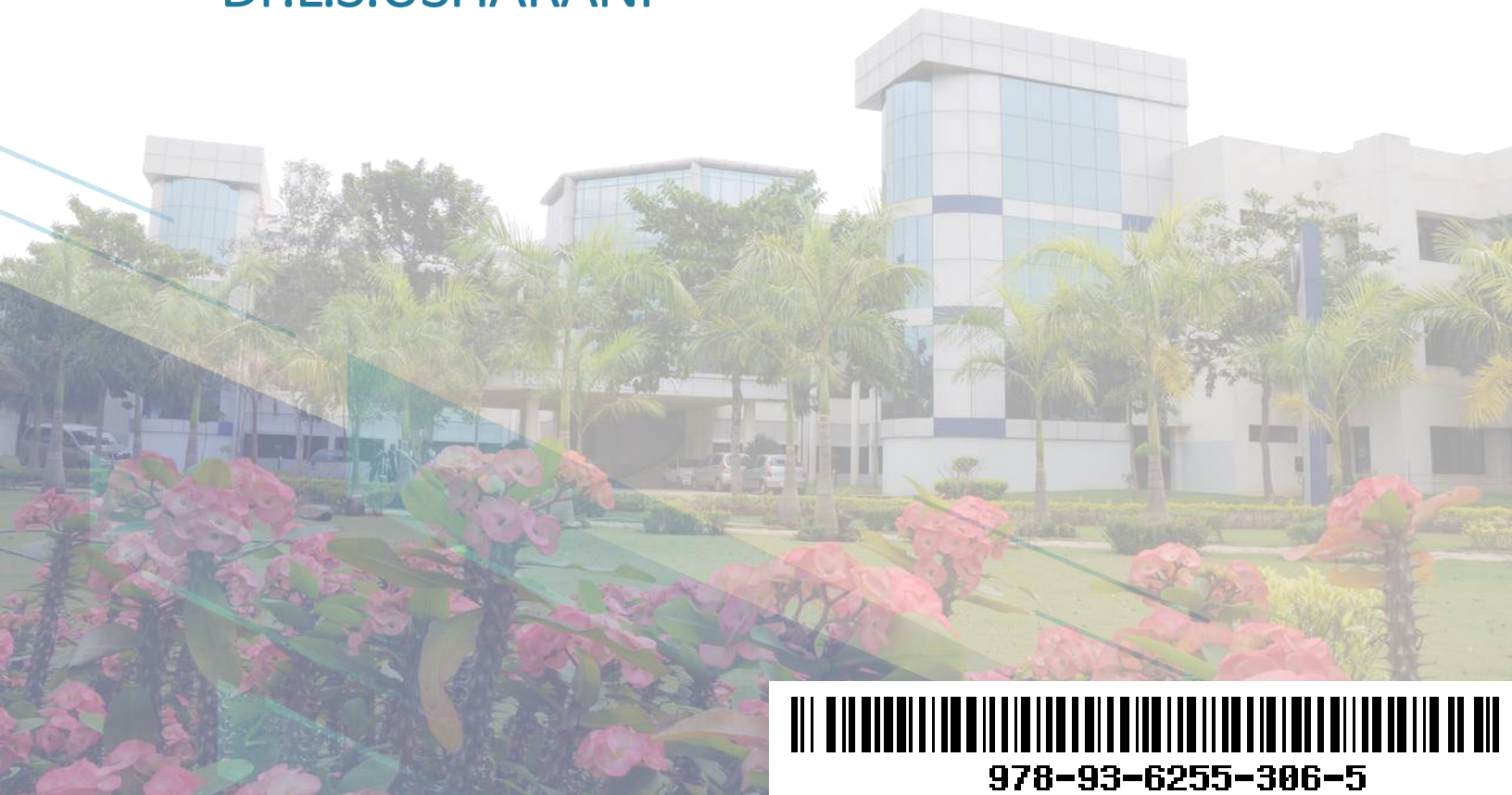

978-93-6255-306-5

SOCIAL NETWORK SECURITY

Copyright © 2023 by Dr.L.S.Usharani

All rights reserved. No part of this book may be reproduced or transmitted in any form or by any means without written permission from the author.

ISBN: 978-93-6255-306-5

Publisher: PonnaiyahRamajayam Institute of Science and Technology (PRIST)

TABLE OF CONTENTS

| | | |
|--|---|------------|
| Introduction | - | 03 |
| CHAPTER 1 – Fundamentals of Social Networking | - | 10 |
| Ms.M.MohanaPriya | | |
| CHAPTER 2 – Security Issues In Social Networks | - | 47 |
| Ms.N.Dhivya | | |
| CHAPTER 3 – Extraction And Mining In Social Networking Data | - | 65 |
| Dr.L.S.Usharani | | |
| CHAPTER 4 – Predicting Human Behavior and Privacy Issues | - | 113 |
| Dr.L.S.Usharani | | |
| CHAPTER 5 – Access Control, Privacy and Identity Management | - | 145 |
| Ms.S.Gayathiri | | |
| CHAPTER 6 – Data Encryption and Storage | - | 153 |
| Ms.M.MohanaPriya | | |
| CHAPTER 7 – Data Backup and Recovery | - | 172 |
| Ms.N.Dhivya | | |
| CHAPTER 8 – User Education and Awareness | - | 185 |
| Ms.M.Jeeva | | |
| CHAPTER 9 – Data Privacy and Compliance | - | 213 |
| MS.M.Jeeva | | |
| CHAPTER 10 – Secure User Behavior | - | 245 |
| Ms.S.Gayathiri | | |
| REFERENCES | - | 25 |

CHAPTER 1

Fundamentals of Social Networking

Ms.M.MohanaPriya

Definition and Purpose

- **Social Networking:** The practice of creating, maintaining, and fostering online connections and interactions between individuals or groups through platforms designed for social interaction.
- **Purpose:** To connect people with shared interests, build communities, share information, foster relationships, and engage in discussions.

Key Elements of Social Networks

- **Profiles:** User-created pages that contain personal information, interests, and activities.
- **Connections:** Links or relationships formed between users, such as friends, followers, or connections.
- **Content Sharing:** Users can post, share, like, and comment on various content types, including text, images, videos, and links.
- **Groups and Communities:** Dedicated spaces for users with shared interests to interact and discuss topics.
- **Privacy Settings:** Tools for users to control who can see their profile, posts, and personal information.

Types of Social Networking Platforms

- **General Platforms:** For broad social interaction (e.g., Facebook, Twitter, Instagram).
- **Professional Networks:** Focused on career growth and professional connections (e.g., LinkedIn).
- **Niche Networks:** Focused on specific interests, hobbies, or demographics (e.g., Goodreads for books, Strava for athletes).
- **Content-Specific Networks:** Emphasize particular types of content (e.g., YouTube for videos, TikTok for short-form videos).

Features of Social Networking Sites

- **User-Generated Content:** Content created and shared by users, such as posts, photos, and videos.
- **Algorithms:** Systems that determine what content is shown to users based on relevance, engagement, and other factors.
- **Notifications:** Alerts to keep users updated on activities and content related to their interests.
- **Direct Messaging:** Private communication between users.
- **Advertising and Monetization:** Methods used by platforms to generate revenue, such as targeted ads, sponsored posts, and premium memberships.

CHAPTER 2

Security Issues In Social Networks

Ms.N.Dhivya

Social networks are popular platforms for communication, sharing information, and building communities, but they also pose several security risks to users and organizations. Here are some of the key security issues:

1. Privacy Concerns

- **Data Collection and Sharing:** Social networks often collect extensive personal data from users, including contact information, location, browsing habits, and interests. This data may be shared with third parties, such as advertisers, or used for targeted advertising, which can lead to privacy violations.
- **Unauthorized Access and Data Breaches:** Hackers may exploit vulnerabilities to access and steal personal data from social networking platforms. Data breaches can expose sensitive user information like passwords, emails, and private messages.

2. Identity Theft and Impersonation

- **Phishing Attacks:** Social networks are common targets for phishing attacks, where attackers create fake profiles or send deceptive messages to trick users into revealing sensitive information, such as passwords or financial details.
- **Impersonation:** Attackers may create fake accounts using another person's identity to deceive friends, family, or followers, often for financial gain or to spread misinformation.

3. Malware and Malicious Links

- **Malware Distribution:** Cybercriminals may use social networks to distribute malware by sharing infected files, links, or advertisements. Clicking on these malicious links can compromise user devices and data.
- **Malicious Apps and Plugins:** Third-party apps or plugins connected to social networks can pose security risks if they contain vulnerabilities or request excessive permissions that allow them to access private data.

Mitigation Strategies for Security Issues

1. **Use Strong, Unique Passwords:** Encourage users to create strong, unique passwords and use password managers to avoid password reuse.
2. **Enable Multi-Factor Authentication (MFA):** Implement MFA for an additional layer of security beyond passwords.
3. **Educate Users on Phishing and Social Engineering:** Provide training and resources to help users recognize and avoid phishing attacks and social engineering tactics.
4. **Regular Software Updates and Patches:** Ensure that social networking platforms and connected apps are regularly updated to patch vulnerabilities.

CHAPTER 3

Extraction And Mining In Social Networking Data

Dr.L.S.Usharani

Extraction and mining in social networking data involve analyzing and processing the vast amount of information generated on social media platforms to extract meaningful patterns, trends, and insights. Here is a set of notes on the key concepts, techniques, and applications involved in this process:

1. Introduction to Social Networking Data

- **Social Networks:** Platforms where users interact, share information, and form connections (e.g., Facebook, Twitter, LinkedIn).
- **Data Types:** Includes user-generated content (text, images, videos), metadata (timestamps, geolocations), and interaction data (likes, shares, comments).
- **Characteristics:** Large volume, high velocity, varied types (structured, semi-structured, unstructured), and complex relationships.

2. Data Collection Techniques

- **APIs:** Application Programming Interfaces provided by platforms to access data (e.g., Twitter API).
- **Web Scraping:** Automated methods to extract data from web pages.
- **Data Formats:** Common formats include JSON, CSV, XML, which may need pre-processing.

3. Data Preprocessing

- **Cleaning:** Removing noise, irrelevant information, duplicates, and dealing with missing data.
- **Normalization:** Standardizing text (e.g., lowercasing, removing punctuation), converting data into a uniform format.
- **Tokenization:** Splitting text into meaningful chunks (tokens) like words or phrases.

4. Social Network Analysis (SNA)

- **Nodes and Edges:** Basic units representing entities (users) and their connections (friendships, follows).
- **Graph Representation:** Social networks are modeled as graphs; nodes represent users and edges represent relationships or interactions.
- **Key Metrics:**
 - **Degree Centrality:** Number of direct connections a node has.
 - **Betweenness Centrality:** Measure of a node's role in connecting other nodes.
 - **Closeness Centrality:** How close a node is to all other nodes in the network.

CHAPTER 4

Predicting Human Behavior and Privacy Issues

Dr.L.S.Usharani

Predicting human behavior involves using data from social networks and other sources to anticipate future actions, preferences, or decisions of individuals or groups. This field is vital for applications in marketing, public policy, security, and personalized services.

Types of Predictions

- **User Engagement:** Predicting actions such as likes, shares, comments, or click-through rates.
- **Behavioral Changes:** Identifying potential changes in user behavior over time (e.g., churn prediction in subscription services).
- **Sentiment and Emotion:** Forecasting shifts in public sentiment or emotional responses to events, products, or policies.

Techniques for Predicting Human Behavior

- **Natural Language Processing (NLP):** Analyzing text data to understand user sentiment, topics of interest, or intent (e.g., sentiment analysis, topic modeling).
- **Time Series Analysis:** Understanding patterns over time to predict future behavior (e.g.,

Applications of Predicting Human Behavior

- **Marketing and Advertising:** Personalized recommendations, targeted ads, and campaign effectiveness analysis.
- **Social Good:** Identifying vulnerable individuals or communities needing support (e.g., mental health crisis detection).
- **Security and Surveillance:** Detecting fraudulent activities, identifying potential threats, and monitoring for suspicious behavior.

Privacy Issues in Social Networking Data

Privacy issues are significant concerns when mining social network data. The collection, analysis, and sharing of personal data raise ethical, legal, and security challenges.

Types of Privacy Concerns

- **Data Privacy:** Protecting user data from unauthorized access, breaches, and misuse.
- **Surveillance:** Concerns about constant monitoring and profiling of individuals by companies, governments, or malicious actors.
- **Data Ownership:** Questions about who owns the data generated by users on social platforms.

CHAPTER 5

Access Control, Privacy and Identity Management

Ms.S.Gayathiri

Access control refers to the methods and policies used to regulate who can view, modify, or use resources in a computing environment. It ensures that only authorized users can access or perform specific actions on data.

Access Control Models in Social Networking

- User Permissions: Defining who can view, edit, share, or delete content (e.g., post visibility settings on Facebook).
- Group-Based Access: Managing access based on group memberships (e.g., access to private groups or communities).

Privacy in Social Networking

Privacy involves the protection of personal information from unauthorized access, use, or disclosure. In social networks, privacy concerns revolve around the control users have over their data and how it is shared.

Privacy Principles

- Data Minimization: Collecting only the data necessary for a specific purpose.
- Purpose Limitation: Using data only for the purposes specified at the time of collection.

Privacy Controls in Social Networks

- Privacy Settings: Allowing users to control the visibility of their profiles, posts, and other content (e.g., public, friends only, private).
- Data Sharing Preferences: Enabling users to manage how their data is shared with third parties, apps, and advertisers.

Identity Management

Identity management involves creating, maintaining, and governing user identities and their associated access rights within an organization or system. It ensures that the right individuals have access to the right resources at the right times.

Key Components of Identity Management

- Identity Lifecycle Management: Managing the entire lifecycle of a user's digital identity, from creation (onboarding) to modification (updating roles or permissions) and deletion (offboarding).

CHAPTER 6

Data Encryption and Storage

Ms.M.MohanaPriya

Data Encryption and Storage refers to the practice of using cryptographic techniques to protect data while it is stored on a physical or digital medium. Encryption ensures that data remains confidential and secure, preventing unauthorized access and protecting sensitive information from being compromised, even if the storage medium is lost, stolen, or breached.

Key Concepts:

1. **Data at Rest:** This refers to data that is stored on a device (e.g., a hard drive, cloud storage, database) and is not being actively transmitted or processed. Data encryption for storage primarily focuses on protecting **data at rest**.
2. **Encryption Algorithms:** Encryption transforms readable data (plaintext) into unreadable data (ciphertext) using algorithms and keys. Common encryption algorithms used for storage include:
 - **AES (Advanced Encryption Standard):** A widely used and highly secure encryption standard.
 - **RSA:** An asymmetric encryption algorithm often used for encrypting keys, but not usually for encrypting large data due to performance limitations.
 - **Blowfish/Twofish:** Alternatives to AES that are sometimes used for encrypting data.
3. **Key Management:** Secure storage of encryption keys is crucial for protecting encrypted data. If encryption keys are compromised, the data can be decrypted. Key management strategies include using hardware security modules (HSMs) or cloud-based key management services.

Types of Data Encryption for Storage:

1. **Full Disk Encryption (FDE):**
 - Encrypts all the data on a disk or storage device, protecting it if the device is lost or stolen.
 - Popular solutions include **BitLocker** (Windows) and **FileVault** (macOS).
 - **Self-Encrypting Drives (SEDs):** Some hardware, such as hard drives or SSDs, have built-in encryption to automatically encrypt all stored data.
2. **File-Level Encryption:**
 - Encrypts individual files or directories, leaving other parts of the storage unencrypted.
 - Offers more granular control than full-disk encryption, allowing different levels of protection for different files.
 - Examples: **EFS (Encrypting File System)** in Windows, and **GnuPG (GPG)** for encrypting files on Linux.
3. **Database Encryption:**
 - Databases can store large amounts of sensitive information (e.g., personal data, financial records), so database encryption is crucial.

CHAPTER 7

Data Backup and Recovery

Ms.N.Dhivya

Data Backup and Recovery is the process of creating copies of data to protect against data loss and restoring it to a previous state after a failure, corruption, or disaster. It is a critical part of any data management strategy, ensuring that organizations and individuals can recover important information in the event of hardware failures, accidental deletions, cyberattacks, or natural disasters.

1. **Full Backup:** A complete copy of all data is made during each backup session. It is the most comprehensive but requires the most storage space and time to complete.
 - **Pros:** Fast and easy recovery, as all data is available in one backup.
 - **Cons:** Time-consuming and requires significant storage capacity.
2. **Incremental Backup:** Only the data that has changed since the last backup (whether full or incremental) is copied. This reduces the time and storage space required for backups.
 - **Pros:** Faster and requires less storage than full backups.
 - **Cons:** Recovery may be slower since multiple backup sets must be restored in sequence (first the full backup, then each incremental).
3. **Differential Backup:** Copies all the data that has changed since the last full backup. It requires more storage than incremental backups but is easier to restore, as only the last full backup and the latest differential backup are needed.
 - **Pros:** Quicker to restore compared to incremental backups.
 - **Cons:** Over time, differential backups can become almost as large as full backups, especially if data changes frequently.
4. **Mirror Backup:** Creates an exact copy of the source data, which is continuously updated to reflect any changes. This provides real-time data availability but does not protect against accidental deletions or corruption unless previous versions are stored.
 - **Pros:** Real-time replication ensures data is always current.
 - **Cons:** If data is accidentally deleted or corrupted, the same happens to the backup.
5. **Synthetic Full Backup:** Combines full and incremental backups into a new full backup. This process saves time by synthesizing the backup from previous full and incremental backups without the need to copy the entire data set again.
 - **Pros:** Faster than a traditional full backup but with the same restoration benefits.
 - **Cons:** Requires more processing to create the synthetic backup.

Types of Backup Storage:

1. **Local Backup:**
 - Stored on local devices such as external hard drives, USB drives, or network-attached storage (NAS).
 - **Pros:** Fast recovery due to proximity; cost-effective.
 - **Cons:** Vulnerable to physical damage (e.g., fire, theft, water damage).

CHAPTER 8

User Education and Awareness

Ms.M.Jeeva

User Education and Awareness refers to the process of educating and informing individuals—whether employees, customers, or general users—about best practices, risks, and responsibilities related to technology, cybersecurity, and data protection. By increasing awareness and knowledge, organizations and individuals can minimize security risks, enhance productivity, and protect sensitive information.

Importance of User Education and Awareness:

1. **Reduces Security Risks:** Many security breaches occur due to human error, such as clicking on phishing links or using weak passwords. User education helps mitigate these risks by equipping individuals with knowledge and tools to make better decisions.
2. **Enhances Productivity:** Well-educated users are more efficient and productive in using technology, reducing downtime and avoiding errors related to improper use of software and systems.
3. **Promotes Compliance:** Many industries require organizations to meet certain compliance standards for data protection. Educating employees ensures that they understand and follow these regulations, minimizing the risk of non-compliance and related penalties.

Key Areas of Focus for User Education and Awareness:

1. **Phishing Awareness:**
 - Educate users about recognizing phishing emails, suspicious links, and social engineering tactics.
 - Train them to report such incidents and avoid falling victim to fraud.
2. **Password Management:**
 - Encourage the use of strong, unique passwords and regular password updates.
 - Introduce tools like password managers to help users securely store and manage credentials.
 - Implement multi-factor authentication (MFA) to add an extra layer of security.
3. **Mobile Device Security:**
 - Teach users how to secure their mobile devices through password protection, encryption, and avoiding unsecured Wi-Fi networks.
 - Emphasize the importance of not downloading suspicious apps and protecting devices from loss or theft.
4. **Social Engineering Prevention:**
 - Provide training on how to recognize and prevent social engineering attacks where cybercriminals manipulate individuals into divulging confidential information.
 - Simulate real-world social engineering scenarios to teach users practical skills.
 -

CHAPTER 9

Data Privacy and Compliance

Ms.M.Jeeva

Data Privacy and Compliance refers to the practices, regulations, and technologies designed to protect sensitive personal and organizational data while ensuring that organizations comply with legal requirements and industry standards. This area is critical in safeguarding individuals' privacy rights and ensuring businesses manage, process, and store data responsibly and transparently.

Key Concepts of Data Privacy and Compliance:

- 1. Data Privacy:**
 - The right of individuals to control how their personal information is collected, used, and shared.
 - Focuses on protecting personal data such as names, email addresses, financial information, health records, and any other sensitive information.
 - Includes practices like data anonymization, data minimization (collecting only necessary data), and obtaining consent for data use.
- 2. Data Compliance:**
 - The process of ensuring that an organization adheres to the legal frameworks, regulations, and standards governing how personal and organizational data should be handled.
 - Involves regular audits, risk assessments, and implementing technical controls to comply with regulations.
- 3. Sensitive Data:**
 - Information that, if exposed or misused, could result in harm to an individual or organization. This includes personal identifiers (PII), financial data, healthcare records, and intellectual property.

Importance of Data Privacy and Compliance:

- 1. Protection of Individual Rights:** Ensures that personal data is handled with care, respecting individuals' rights to privacy and freedom from unauthorized surveillance or exploitation.
- 2. Legal and Regulatory Requirements:** Failing to comply with data privacy regulations can result in severe penalties, fines, and legal consequences for businesses.

Key Regulations Governing Data Privacy and Compliance:

- 1. General Data Protection Regulation (GDPR):**
 - The GDPR is a European Union regulation designed to protect individuals' privacy and personal data. It applies to all organizations that process the data of EU citizens, regardless of where the organization is based.
 - **Lawfulness, Fairness, and Transparency:** Data must be processed lawfully, transparently, and for a specific purpose.

CHAPTER 10

Secure User Behavior

Ms.S.Gayathiri

Secure User Behavior refers to the practices and habits that individuals adopt to protect themselves and their organizations from security threats in digital environments. As cyberattacks increasingly target human weaknesses (like phishing and social engineering), fostering secure behavior is essential for reducing the risk of data breaches, identity theft, and other cyber incidents.

Promoting Secure User Behavior:

1. Regular Security Training:

- Conduct periodic cybersecurity awareness training to ensure users understand evolving threats and the latest best practices.
- Simulate phishing attacks to test user awareness and provide corrective training for those who fall victim to simulated threats.

2. Clear Security Policies:

- Develop and communicate clear security policies that outline acceptable behaviors, data handling practices, and guidelines for secure device use.
- Ensure users understand how to report security incidents and whom to contact in case of a suspected breach.

3. Incentives for Secure Practices:

- Encourage secure behavior by offering incentives or recognition for employees who demonstrate vigilance or identify potential security risks.

4. Monitoring and Feedback:

- Use monitoring tools to detect insecure behaviors, such as weak passwords or unsecured file sharing, and provide feedback or training to address those issues.
- Foster a **blame-free culture** where users feel comfortable reporting mistakes or suspicious activities without fear of punishment.

5. Leverage Technology:

- Implement **endpoint security** measures like firewalls, anti-virus software, and DLP systems to automatically enforce security policies and protect users.
- Use **data classification** tools to help users identify and appropriately handle sensitive information based on its level of confidentiality.

6. Personal Accountability:

- Encourage a culture of personal responsibility where each user is aware of their role in maintaining security and is proactive in identifying potential threats.

7. Security Updates and Patches:

- Remind users to regularly update their software and systems to protect against vulnerabilities and ensure that security patches are installed.
- **Common Threats Mitigated by Secure User Behavior:**

1. **Phishing Attacks:** Users who recognize phishing tactics and avoid clicking on malicious links help prevent malware and credential theft.



ETHICAL HACKING

Edited by

M.MOHANA PRIYA



978-93-6255-327-0

ETHICAL HACKING

Copyright © 2023 by M.MOHANA PRIYA

All rights reserved. No part of this book may be reproduced or transmitted in any form or by any means without written permission from the author.

ISBN: 978-93-6255-327-0

Publisher: PonnaiyahRamajayam Institute of Science and Technology (PRIST)

TABLE OF CONTENTS

| | | |
|---|---|------------|
| Introduction | - | 03 |
| CHAPTER 1 – Foot Printing , Reconnaissance and Scanning Networks | - | 11 |
| Ms.N.Dhivya | | |
| CHAPTER 2 – System Hacking | - | 47 |
| Ms.M.Jeeva | | |
| CHAPTER 3 – Android Hacking Using Reverse TCP Connection | - | 73 |
| Ms.M.MohanaPriya | | |
| CHAPTER 4 – Reverse TCP Connection | - | 129 |
| Dr.R.Latha | | |
| CHAPTER 5 – Show Software based Vulnerabilities | - | 145 |
| Ms.S.Gayathiri | | |
| CHAPTER 6 – Password Cracking and Brute Forcing | - | 158 |
| Ms.N.Dhivya | | |
| CHAPTER 7 – Backdoors and Trojans | - | 176 |
| Ms.M.Jeeva | | |
| CHAPTER 8 – Rootkits and Kernel Mode Malware | - | 193 |
| Ms.M.Jeeva | | |
| CHAPTER 9 – Wireless Hacking and Security | - | 219 |
| Dr.R.Latha | | |
| CHAPTER 10 – Network Security Measures | - | 235 |
| Ms.S.Gayathiri | | |
| REFERENCES | - | 257 |

CHAPTER 1

Foot Printing , Reconnaissance and Scanning Networks

Ms.N.Dhivya

Footprinting, Reconnaissance, and Scanning Networks," which are crucial concepts in the fields of cybersecurity, ethical hacking, and network security:

Footprinting is the process of gathering as much information as possible about a target system or network to identify potential vulnerabilities and entry points. It is the first step in the information-gathering phase of ethical hacking and penetration testing.

Purpose of Footprinting

- **To Gather Information:** Collect data about the target's network infrastructure, operating systems, applications, and users.
- **To Identify Weaknesses:** Understand the target's security posture, identify potential vulnerabilities, and plan an attack strategy.

Footprinting Techniques

- **WHOIS Lookup:** Querying databases to get details about domain ownership, IP addresses, and DNS information.
- **DNS Enumeration:** Gathering information about domain names, IP addresses, and subdomains using DNS records.

Reconnaissance

Reconnaissance is the second phase, where more in-depth information is collected after initial footprinting. It is the process of gathering detailed information about the target's network, systems, and architecture to find potential vulnerabilities.

Scanning Networks

Network scanning involves using specialized tools and techniques to detect live systems, open ports, running services, and vulnerabilities on a target network. It is a more focused and detailed phase of reconnaissance.

Scanning Techniques

- **UDP Scanning:** Scans for open UDP ports. It is slower and less reliable due to the lack of an acknowledgment mechanism in the UDP protocol.
- **Stealth Scanning:** Techniques such as FIN, Xmas, or NULL scans to avoid detection by security mechanisms.
- **Fragmentation Scanning:** Sends fragmented packets to avoid detection by firewalls and intrusion detection systems (IDS).

CHAPTER 2

System Hacking

Ms.M.Jeeva

System Hacking," which refers to the process of exploiting vulnerabilities in a computer system or network to gain unauthorized access, escalate privileges, or achieve other malicious objectives. It is a critical phase in ethical hacking and penetration testing. System hacking involves exploiting security weaknesses in a system to gain unauthorized access or perform malicious actions. The primary goals include gaining access, escalating privileges, maintaining access, and covering tracks.

Objectives of System Hacking

- **Gain Access:** Obtain unauthorized access to a system or network.
- **Escalate Privileges:** Elevate access rights to gain more control over the target system.
- **Execute Applications:** Run malicious or unauthorized programs on the target system.
- **Maintain Access:** Ensure continuous access to the compromised system.
- **Cover Tracks:** Hide evidence of hacking activities to avoid detection and removal.

System Hacking Steps

System hacking typically involves several sequential steps to achieve the hacker's objectives:

Gaining Access

- **Password Cracking:** Attempting to recover passwords to gain access to user accounts.
 - **Brute Force Attack:** Trying all possible combinations until the correct one is found.
 - **Dictionary Attack:** Using a precompiled list of potential passwords.
 - **Hybrid Attack:** Combines dictionary and brute-force attacks to crack passwords.
 - **Rainbow Tables:** Using precomputed hash values to crack hashed passwords quickly.
- **Exploiting Vulnerabilities:** Finding and using software vulnerabilities to gain unauthorized access.
 - **Buffer Overflow:** Exploiting coding errors where more data is written to a buffer than it can hold, allowing the execution of arbitrary code.
 - **SQL Injection:** Injecting malicious SQL queries into input fields to manipulate databases.
 - **Remote Code Execution (RCE):** Exploiting flaws that allow running commands on a remote system.
- **Social Engineering:** Manipulating people to divulge confidential information or perform actions that facilitate system hacking (e.g., phishing).

CHAPTER 3

Android Hacking Using Reverse TCP Connection

Ms.M.MohanaPriya

Android hacking via reverse TCP connections involves gaining unauthorized access to an Android device by establishing a reverse connection from the device to the attacker's machine. This technique is often used in penetration testing and ethical hacking to test the security of Android applications and systems.

Reverse TCP Connection

- **Reverse TCP Connection:** A technique where the target device initiates a connection to the attacker's machine. This is useful when the target is behind a firewall or NAT, making it difficult for the attacker to initiate a connection.

Tools Required:

- **Metasploit Framework:** A popular tool for exploiting vulnerabilities and creating payloads.
- **Netcat (nc):** A utility for reading and writing data across network connections using TCP/IP.
- **Android Emulator or Device:** A physical Android device or emulator for testing.

Post-Exploitation

Once the connection is established, the attacker can perform various actions, such as:

- **Meterpreter Sessions:** Use Metasploit's Meterpreter shell to execute commands, capture screenshots, or access files on the Android device.
- **Data Extraction:** Extract sensitive information such as contacts, messages, and application data.
- **Remote Control:** Gain full control over the device, including accessing the camera and microphone.

Defensive Measures

- **Install Apps from Trusted Sources:** Avoid installing APKs from untrusted sources.
- **Use Security Software:** Install and regularly update antivirus and anti-malware software.
- **Keep the OS Updated:** Regularly update the Android OS and applications to patch known vulnerabilities.
- **Network Security:** Use firewalls and intrusion detection systems to monitor and protect network traffic.

CHAPTER 4

Reverse TCP Connection

Dr.R.Latha

A Reverse TCP Connection is a technique used in network communications and cybersecurity where a target machine initiates a connection to an attacker's machine, rather than the attacker initiating the connection. This method is often employed to bypass firewalls or Network Address Translation (NAT) devices that might block incoming connections from external sources.

How Reverse TCP Connections Work

- 1. Initiation by Target:**
 - In a reverse TCP connection, the target machine (e.g., a compromised system or device) initiates the connection to the attacker's machine. This can be advantageous when the target is behind a firewall or NAT, which blocks incoming connections.
- 2. Connection Establishment:**
 - The attacker sets up a listener on their machine, waiting for an incoming connection. Once the target machine establishes the connection, the attacker can interact with the target system.
- 3. Communication:**
 - After the connection is established, the attacker can send and receive data from the target machine. This setup allows remote control, data exfiltration, and other actions.

Use Cases

- 1. Penetration Testing:**
 - Ethical hackers use reverse TCP connections to test the security of systems and networks. This helps in identifying vulnerabilities and weaknesses in a controlled manner.
- 2. Malware and Exploits:**
 - Attackers may use reverse TCP connections to gain unauthorized access to systems by exploiting vulnerabilities or using malware to establish a connection.

Setting Up a Reverse TCP Connection

Generating the Payload:

- Use tools like Metasploit to create a payload that will establish a reverse TCP connection from the target machine to the attacker's machine.

CHAPTER 5

Show Software based Vulnerabilities

Ms.S.Gayathiri

Software-based vulnerabilities are weaknesses or flaws in software that can be exploited by attackers to gain unauthorized access, compromise systems, or disrupt operations. Understanding these vulnerabilities is crucial for securing software applications and systems.

Types of Software-Based Vulnerabilities

1. Buffer Overflow

- **Definition:** Occurs when a program writes more data to a buffer than it can hold, leading to potential overwriting of adjacent memory.
- **Consequences:** Can lead to arbitrary code execution, system crashes, or data corruption.
- **Example:** Writing data beyond the allocated memory buffer in a C program.

2. SQL Injection

- **Definition:** Exploits vulnerabilities in web applications by injecting malicious SQL queries into input fields, manipulating the database.
- **Consequences:** Unauthorized access to database information, data manipulation, or deletion.
- **Example:** Accepting unsanitized input in a web form that is then processed by the application.

Common Vulnerability Sources

1. Coding Errors:

- **Definition:** Mistakes or oversights made by developers during the coding process.
- **Examples:** Off-by-one errors, incorrect handling of user input.

2. Configuration Issues:

- **Definition:** Incorrect or insecure configurations of software or systems.
- **Examples:** Default credentials, insecure permissions.

3. Identifying and Mitigating Vulnerabilities

1. Static Analysis:

- **Definition:** Analyzing source code or binaries without executing the program.
- **Tools:** SonarQube, Checkmarx.

2. Dynamic Analysis:

- **Definition:** Testing the software while it is running to identify vulnerabilities.
- **Tools:** OWASP ZAP, Burp Suite.

3. Penetration Testing:

- **Definition:** Simulating attacks to identify and exploit vulnerabilities.
- **Tools:** Metasploit, Nessus.

CHAPTER 6

Password Cracking and Brute Forcing

Ms.N.Dhivya

Password Cracking and **Brute Forcing** are techniques used by attackers to gain unauthorized access to systems by guessing or deciphering passwords. Understanding these methods is crucial for implementing effective security measures to protect against them.

Password Cracking

Password Cracking is the process of recovering passwords from data that has been stored or transmitted by exploiting weaknesses in password security.

Common Password Cracking Techniques:

- 1. Dictionary Attacks:**
 - **Description:** Uses a list of pre-defined passwords (dictionary) to attempt login. The list may include common passwords, variations, and passwords from known breaches.
 - **Effectiveness:** Effective against weak passwords and passwords found in common lists. It is fast if the password is common.
- 2. Brute Force Attacks:**
 - **Description:** Tries all possible combinations of characters until the correct one is found. This method guarantees success eventually but can be time-consuming.
 - **Effectiveness:** Effective for short or simple passwords. The time required increases exponentially with the length and complexity of the password.
- 3. Rainbow Tables:**
 - **Description:** Uses pre-computed tables of hash values for various passwords to quickly find a match for a given hashed password. Rainbow tables reduce the need to compute hashes on-the-fly but are mitigated by using salt (random data added to passwords before hashing).
 - **Effectiveness:** Effective against unsalted hashes but less so against salted hashes or more complex password schemes.
- 4. Hybrid Attacks:**
 - **Description:** Combines dictionary and brute force techniques. It starts with common passwords and then modifies them (e.g., adding numbers or symbols) to account for common variations.
 - **Effectiveness:** Effective against passwords that are variations of common words or phrases.
- 5. Social Engineering:**
 - **Description:** Manipulates individuals into revealing their passwords through deception or psychological manipulation.
 - **Effectiveness:** Highly effective when users are not cautious or aware of social engineering tactics.
- 6. Phishing:**
 - **Description:** Uses fake emails or websites to trick users into entering their passwords.
 - **Effectiveness:** Effective if users fall for the deception and enter their credentials on fake sites.

CHAPTER 7

Backdoors and Trojans

Ms.M.Jeeva

Backdoors and **Trojans** are types of malware that can compromise the security of systems and networks, often giving unauthorized access or control to attackers. Understanding these threats and their implications is crucial for maintaining robust cybersecurity.

Backdoors

Backdoors are secret methods or vulnerabilities intentionally installed by attackers or malicious software to bypass normal authentication mechanisms and gain unauthorized access to a system or network.

Characteristics of Backdoors:

1. **Purpose:**
 - Provide persistent access to a system even if other security measures are in place.
 - Allow attackers to bypass security controls, making it easier to exploit or control the compromised system.
2. **Types:**
 - **Software Backdoors:** Hidden features or code within software that allow unauthorized access. They might be installed intentionally by developers with malicious intent or by attackers exploiting vulnerabilities.
3. **Common Methods of Installation:**
 - **Exploiting Vulnerabilities:** Attackers use known vulnerabilities in software or hardware to install a backdoor.
 - **Malicious Software:** Malware such as Trojans can install backdoors as part of their payload.

Trojans (or Trojan horses) are a type of malware disguised as legitimate software or files that, once executed, perform malicious actions on the infected system.

Characteristics of Trojans:

1. **Purpose:**
 - Disguise themselves as benign or useful software to trick users into installing them.
 - Once installed, Trojans can perform a range of malicious activities, including stealing data, installing additional malware, or creating backdoors for remote access.
2. **Types:**
 - **Remote Access Trojans (RATs):** Allow attackers to control the infected system remotely, accessing files, webcams, and other resources.

CHAPTER 8

Rootkits and Kernel Mode Malware

Ms.M.Jeeva

Rootkits and **Kernel Mode Malware** are advanced types of malware that operate at a low level in the system, making them particularly difficult to detect and remove. They can give attackers high levels of control over a compromised system.

Rootkits

Rootkits are malicious tools designed to hide the presence of other malware or unauthorized activities on a system by altering the operating system or its components.

Characteristics of Rootkits:

1. **Purpose:**
 - Conceal the presence of malware or malicious activities from detection mechanisms like antivirus programs or system monitors.
 - Provide attackers with persistent, often undetectable, access to a system.
2. **Types:**
 - **User Mode Rootkits:** Operate at the user level and typically modify system calls or application behaviors to hide their presence. They can alter or intercept system processes, files, and registry entries.
 - **Kernel Mode Rootkits:** Operate at the kernel level (the core of the operating system) and have the ability to modify kernel functions and system processes, making them harder to detect.
3. **Common Methods of Installation:**
 - **Exploiting Vulnerabilities:** Attackers exploit system vulnerabilities or weaknesses to install a rootkit.
 - **Social Engineering:** Rootkits can be delivered via phishing emails or malicious
4. **Mitigation:**
 - **Regular Updates and Patches:** Keep operating systems and software up to date to protect against known vulnerabilities.
 - **Strong Access Controls:** Limit user privileges and use strong authentication mechanisms to reduce the risk of unauthorized access.

Kernel Mode Malware

Kernel Mode Malware operates at the kernel level of an operating system, where it can gain high-level control over the system. This type of malware can modify system internals, including drivers and kernel functions, making it difficult to detect and remove.

CHAPTER 9

Wireless Hacking and Security

Dr.R.Latha

Wireless Hacking and Security involve the techniques and measures associated with securing wireless networks and understanding the methods used by attackers to exploit vulnerabilities in these networks. Wireless networks, such as Wi-Fi, are widely used but can be susceptible to various types of attacks if not properly secured.

Wireless Hacking

Wireless Hacking refers to the methods used by attackers to gain unauthorized access to wireless networks or intercept data transmitted over wireless channels.

Common Wireless Hacking Techniques:

1. **WEP Cracking:**
 - **Description:** WEP (Wired Equivalent Privacy) is an outdated and insecure encryption protocol for Wi-Fi networks. Attackers use tools like Aircrack-ng to capture and analyze encrypted traffic, eventually decrypting it by exploiting weaknesses in the WEP algorithm.
 - **Risks:** WEP is vulnerable to several attacks, including the exploitation of weak initialization vectors (IVs).
2. **WPA/WPA2 Cracking:**
 - **Description:** WPA (Wi-Fi Protected Access) and WPA2 are more secure than WEP but can still be vulnerable. Attackers may use techniques like dictionary attacks to crack WPA/WPA2 passwords, particularly if they are weak or easily guessable.
 - **Tools:** Common tools include Aircrack-ng, Hashcat, and John the Ripper.
3. **Evil Twin Attacks:**
 - **Description:** Attackers set up a rogue access point with the same SSID (network name) as a legitimate network. Unsuspecting users connect to the rogue AP, allowing attackers to intercept data and perform man-in-the-middle attacks.
 - **Mitigation:** Use strong encryption, verify the network SSID, and educate users to avoid connecting to unknown or suspicious networks.
4. **Rogue Access Points:**
 - **Description:** Unauthorized access points are set up within a network to intercept or manipulate traffic. These can be used to steal data or gain unauthorized access to the network.
 - **Detection:** Implement network monitoring tools to detect unauthorized devices and access points.
5. **Man-in-the-Middle Attacks (MitM):**
 - **Description:** Attackers intercept and manipulate communication between two parties. In wireless networks, this can be done by exploiting vulnerabilities in the network or using tools to intercept and decrypt traffic.

CHAPTER 10

Network Security Measures

Ms.S.Gayathiri

Network Security Measures are essential for protecting networks from unauthorized access, attacks, and other security threats. They encompass a wide range of strategies, tools, and practices designed to ensure the integrity, confidentiality, and availability of network resources. Here's a comprehensive overview of key network security measures:

1. Firewalls

Firewalls are a fundamental network security tool that controls incoming and outgoing network traffic based on predetermined security rules.

- **Types:**
 - **Network Firewalls:** Monitor and control network traffic between different network segments.
 - **Host-based Firewalls:** Installed on individual devices to monitor and control traffic to and from that device.
- **Deployment:** Place firewalls at network perimeters and between different network segments.

2. Intrusion Detection and Prevention Systems (IDPS)

IDPS monitor network traffic for suspicious activity and can take actions to prevent or mitigate threats.

- **Intrusion Detection System (IDS):** Alerts administrators to potential security incidents.
- **Intrusion Prevention System (IPS):** Takes proactive measures to block or mitigate threats in real-time.

3. Virtual Private Networks (VPNs)

VPNs provide secure communication channels over public or untrusted networks by encrypting data traffic.

- **Types:**
 - **Remote Access VPNs:** Allow users to securely connect to a network from remote locations.
 - **Site-to-Site VPNs:** Connect different networks securely over the internet.

4. Network Segmentation

Network Segmentation involves dividing a network into smaller segments to limit the spread of attacks and improve security.

SECURITY AND PRIVACY IN CLOUD

Edited by

Dr.R.N.ARULARASAN



978-93-6255-788-7

SECURITY AND PRIVACY IN CLOUD

Copyright © 2023 by Dr.A.N.Arularasan

All rights reserved. No part of this book may be reproduced or transmitted in any form or by any means without written permission from the author.

ISBN: 978-93-6255-708-7

Publisher: PonnaiyahRamajayam Institute of Science and Technology (PRIST)

TABLE OF CONTENTS

| | | |
|--|---|------------|
| Introduction | - | 01 |
| CHAPTER 1 – Fundamentals of Cloud Security Concepts | - | 11 |
| Ms.M.MohanaPriya | | |
| CHAPTER 2 – Security Design and Architecture For Cloud | - | 43 |
| Ms.M.Jeeva | | |
| CHAPTER 3 – Access Control, Privacy and Identity Management | - | 56 |
| Ms.V.Gayathiri | | |
| CHAPTER 4 – Cloud Security Design Patterns | - | 63 |
| Dr.A.N.Arularasan | | |
| CHAPTER 5 –Monitoring ,Auditing and Management | - | 87 |
| Ms.M.Jeeva | | |
| CHAPTER 6 – Cloud Storage Security | - | 103 |
| Ms.M.MohanaPriya | | |
| CHAPTER 7 – Cloud Application Vulnerabilities | - | 116 |
| Ms.M.Jeeva | | |
| CHAPTER 8 – Identity and Access Management | - | 156 |
| Ms.M.Jeeva | | |
| CHAPTER 9 – Cloud Compliance and Regulatory Requirements | - | 173 |
| Ms.M.MohanaPriya | | |
| CHAPTER 10 –Cloud Forensics and Incident Analysis | - | 217 |
| Ms.M.Jeeva | | |
| REFERENCES | - | 267 |

CHAPTER 1

Fundamentals of Cloud Security Concepts

Ms.M.MohanaPriya

Cloud security involves the measures and practices used to protect data, applications, and services hosted in cloud environments. Understanding the core concepts of cloud security is crucial for ensuring the confidentiality, integrity, and availability of cloud-based resources.

1. Key Cloud Security Concepts

1. Shared Responsibility Model

- **Definition:** The cloud security responsibility is shared between the cloud service provider (CSP) and the customer. The exact division of responsibilities depends on the cloud service model (IaaS, PaaS, SaaS).

2. Data Encryption

- **Definition:** Protecting data through encryption both at rest and in transit.
- **At Rest:** Data stored in cloud storage is encrypted to protect it from unauthorized access.

3. Identity and Access Management (IAM)

- **Definition:** Managing and controlling access to cloud resources based on user identities and roles.
- access control (RBAC) and using IAM policies to define access levels.

Cloud Security Models and Architectures

1. Cloud Service Models

- **IaaS (Infrastructure as a Service):** Provides virtualized computing resources over the internet.
- **PaaS (Platform as a Service):** Provides a platform for developing, running, and managing applications.
- **SaaS (Software as a Service):** Delivers software applications over the internet.

2. Cloud Deployment Models

- **Public Cloud:** Services are provided over the public internet and shared among multiple customers. Example: AWS, Microsoft Azure.
- **Private Cloud:** Services are maintained on a private network and dedicated to a single organization. Example: VMware Private Cloud.
- **Hybrid Cloud:** Combines public and private clouds, allowing data and applications to be shared between them. Example: Using public cloud for scalability and private cloud for sensitive data.
- **Community Cloud:** Shared infrastructure for a specific community with common concerns. Example: Cloud resources shared by multiple organizations within the same industry.

CHAPTER 2

Security Design and Architecture For Cloud

Ms.M.Jeeva

Security design and architecture for cloud computing involve the strategies and frameworks implemented to protect cloud-based systems and data from threats and vulnerabilities. It ensures that cloud environments are resilient against attacks and compliant with security policies and regulations.

Key Principles of Cloud Security Design

1. Least Privilege

- **Definition:** Grant only the minimum level of access necessary for users and applications to perform their functions.
- **Implementation:** Use Role-Based Access Control (RBAC) and Attribute-Based Access Control (ABAC) to manage permissions.

2. Defense in Depth

- **Definition:** Implement multiple layers of security controls to protect data and resources.
- **Implementation:** Combine firewalls, encryption, access controls, and monitoring tools to create a robust security posture..

Cloud Security Architecture Components

1. Identity and Access Management (IAM)

- **Components:**
 - **Authentication:** Verify user identities through methods like multi-factor authentication (MFA).

2. Network Security

- **Components:**
 - **Firewalls:** Protect cloud resources by filtering traffic based on rules.
 - **Virtual Private Networks (VPNs):** Securely connect to cloud resources from remote locations.

3. Data Security

- **Components:**
 - **Encryption:** Encrypt data at rest and in transit using strong encryption standards.

4. Application Security

- **Components:**
 - **Secure Development Practices:** Follow secure coding guidelines to avoid vulnerabilities like SQL injection and XSS.

Conclusion Designing and implementing a robust security architecture for cloud environments involves integrating various security components and practices to protect data, applications, and infrastructure. By following security principles, utilizing appropriate tools and frameworks.

CHAPTER 3

Access Control, Privacy and Identity Management

Ms.V.Gayathiri

Access control refers to the methods and policies used to regulate who can view, modify, or use resources in a computing environment. It ensures that only authorized users can access or perform specific actions on data.

Access Control Models in Social Networking

- User Permissions: Defining who can view, edit, share, or delete content (e.g., post visibility settings on Facebook).
- Group-Based Access: Managing access based on group memberships (e.g., access to private groups or communities).

Privacy in Social Networking

Privacy involves the protection of personal information from unauthorized access, use, or disclosure. In social networks, privacy concerns revolve around the control users have over their data and how it is shared.

Privacy Principles

- Data Minimization: Collecting only the data necessary for a specific purpose.
- Purpose Limitation: Using data only for the purposes specified at the time of collection.

Privacy Controls in Social Networks

- Privacy Settings: Allowing users to control the visibility of their profiles, posts, and other content (e.g., public, friends only, private).
- Data Sharing Preferences: Enabling users to manage how their data is shared with third parties, apps, and advertisers.

Identity Management

Identity management involves creating, maintaining, and governing user identities and their associated access rights within an organization or system. It ensures that the right individuals have access to the right resources at the right times.

Key Components of Identity Management

- Identity Lifecycle Management: Managing the entire lifecycle of a user's digital identity, from creation (onboarding) to modification (updating roles or permissions) and deletion (offboarding).

CHAPTER 4

Cloud Security Design Patterns

Dr.A.N.Arularsan

Cloud security design patterns are established solutions or best practices for addressing common security challenges in cloud environments. These patterns help in creating secure, resilient, and compliant cloud architectures. Below are key cloud security design patterns with explanations and use cases.

Network Segmentation and Isolation

Pattern: Network segmentation involves dividing the network into isolated segments to control and limit the flow of traffic. This can help prevent lateral movement of attackers within the network and protect sensitive data.

Defense in Depth

Pattern: Employ multiple layers of security controls to protect data and resources. Each layer provides additional protection and reduces the risk of a single point of failure.

Least Privilege

Pattern: Grant the minimum level of access necessary for users and services to perform their tasks. This principle helps in reducing the attack surface and mitigating potential damage from compromised accounts.

Secure Software Development Lifecycle (SDLC)

Pattern: Integrate security practices into the software development lifecycle to address vulnerabilities early in the development process.

- **Implementation:**
 - **Secure Coding Practices:** Follow best practices for writing secure code.
 - **Security Testing:** Conduct security testing, including static analysis and dynamic analysis, during development.
 - **Vulnerability Management:** Track and address vulnerabilities throughout the software lifecycle.

Conclusion

Implementing these cloud security design patterns helps in creating secure cloud environments by addressing common security challenges and adhering to best practices. By applying these patterns, organizations can enhance their security posture, protect sensitive data, and ensure compliance with regulatory requirements.

CHAPTER 5

Monitoring ,Auditing and Management

Ms.M.Jeeva

Monitoring, auditing, and management are crucial components of cloud security. They help ensure that cloud resources are secure, compliant, and operating as intended. Here's a detailed overview of each component:

Definition: Continuous observation of cloud resources and activities to detect, analyze, and respond to security incidents and performance issues.

Key Components:

1. Log Collection and Aggregation

- **Definition:** Collecting and centralizing logs from various sources such as servers, applications, and network devices.
- **Tools:** AWS CloudWatch, Azure Monitor, Google Cloud Operations Suite (formerly Stackdriver).

2. Real-Time Monitoring

- **Definition:** Tracking system performance and security events in real-time to identify and address issues promptly.
- **Tools:** Prometheus, Grafana, Datadog.

3. Alerting

- **Definition:** Generating notifications for predefined conditions or anomalies that could indicate security threats or operational issues.
- **Tools:** AWS CloudWatch Alarms, Azure Alerts, PagerDuty.

Auditing

Definition: Systematic examination and evaluation of cloud resources, configurations, and activities to ensure compliance with security policies and regulations.

Management

Definition: The ongoing administration and oversight of cloud resources and security measures to ensure they are effectively maintained and optimized.

Resource Management

- **Definition:** Managing the lifecycle of cloud resources, including provisioning, scaling, and decommissioning.
- **Tools:** Cloud management platforms, automation tools.

CHAPTER 6

Cloud Storage Security

Ms.M.MohanaPriya

Cloud Storage Security involves safeguarding data stored in cloud environments from unauthorized access, breaches, and other security threats. As cloud storage solutions become increasingly popular, ensuring their security is critical for protecting sensitive information and maintaining regulatory compliance.

Key Aspects of Cloud Storage Security

1. Data Encryption

Data Encryption is fundamental for protecting data both in transit and at rest within the cloud.

- **In-Transit Encryption:** Encrypt data as it travels between the user and the cloud provider, using protocols like TLS (Transport Layer Security).
- **At-Rest Encryption:** Encrypt data stored in the cloud using strong encryption algorithms (e.g., AES-256). Ensure that encryption keys are managed securely.

2. Access Controls

Access Controls manage who can access and interact with data stored in the cloud.

- **Authentication:** Use strong authentication methods (e.g., Multi-Factor Authentication) to verify user identities.
- **Authorization:** Implement fine-grained access control policies to restrict access based on user roles and permissions.
- **Identity and Access Management (IAM):** Utilize IAM solutions to manage user identities and permissions effectively.

3. Data Backup and Recovery

Data Backup and Recovery ensure that data can be restored in case of loss, corruption, or disaster.

- **Regular Backups:** Schedule regular backups of critical data and test backup procedures to ensure data can be restored effectively.
- **Disaster Recovery Plans:** Develop and implement disaster recovery plans to address potential data loss scenarios.

4. Security Monitoring and Auditing

Security Monitoring and Auditing involve tracking and analyzing activities related to cloud storage to detect and respond to security incidents.

CHAPTER 7

Cloud Application Vulnerabilities

Ms.M.Jeeva

Cloud Application Vulnerabilities refer to weaknesses or flaws in cloud-based applications that can be exploited by attackers to compromise security, access sensitive data, or disrupt services. Addressing these vulnerabilities is crucial for maintaining the security and integrity of cloud applications.

Common Cloud Application Vulnerabilities

1. Misconfigured Cloud Settings

Misconfigured Cloud Settings occur when cloud services or applications are not set up according to best practices, leading to potential security risks.

- **Examples:**
 - **Publicly Accessible Storage:** Cloud storage buckets or databases set to public access instead of restricted access.
 - **Exposed Management Interfaces:** Administrative interfaces exposed to the internet without proper access controls.
- **Mitigation:**
 - Regularly review and audit cloud configurations.
 - Use configuration management tools and best practices for secure setup.

2. Insecure APIs

Insecure APIs can expose applications to attacks if APIs are not properly secured.

- **Examples:**
 - **Lack of Authentication and Authorization:** APIs that do not enforce strong authentication or authorization mechanisms.
 - **Unvalidated Input:** APIs that do not properly validate input, leading to potential injection attacks.
- **Mitigation:**
 - Implement strong authentication and authorization for APIs.
 - Use input validation and sanitize user inputs.
 - Regularly test APIs for security vulnerabilities.

3. Data Breaches

Data Breaches occur when sensitive data is exposed due to vulnerabilities in cloud applications or misconfigurations.

- **Examples:**
 - **Unencrypted Data:** Data stored or transmitted without encryption.

CHAPTER 8

Identity and Access Management

Ms.M.Jeeva

Identity and Access Management (IAM) is a critical component of cybersecurity that ensures the right individuals have the appropriate access to resources within an organization while protecting those resources from unauthorized access. IAM encompasses a range of policies, technologies, and practices used to manage user identities and control access to systems and data.

Key Components of IAM

1. Authentication

Authentication is the process of verifying the identity of a user or system.

- **Methods:**
 - **Password-Based Authentication:** Users provide a password to access resources. While common, it should be combined with other methods for better security.
 - **Multi-Factor Authentication (MFA):** Requires two or more forms of verification (e.g., something the user knows, has, or is) to enhance security.
 - **Biometric Authentication:** Uses biometric data (e.g., fingerprints, facial recognition) to verify identity.
 - **Single Sign-On (SSO):** Allows users to authenticate once and gain access to multiple applications or systems without re-authenticating.

2. Authorization

Authorization determines what resources and actions an authenticated user is allowed to access or perform.

- **Models:**
 - **Role-Based Access Control (RBAC):** Grants access based on the user's role within the organization. Roles are assigned specific permissions.
 - **Attribute-Based Access Control (ABAC):** Grants access based on attributes (e.g., user attributes, resource attributes, environmental conditions).
 - **Policy-Based Access Control (PBAC):** Access decisions are made based on policies that define the conditions under which access is granted or denied.

3. User Management

User Management involves creating, maintaining, and deleting user accounts and profiles.

- **Processes:**
 - **Provisioning:** Creating and assigning user accounts, roles, and permissions.
 - **De-provisioning:** Removing user access when they leave the organization or no longer need access.

CHAPTER 9

Cloud Compliance and Regulatory Requirements

Ms.M.MohanaPriya

Cloud Compliance and Regulatory Requirements refer to the standards and laws that organizations must adhere to when using cloud services. Compliance ensures that cloud services meet specific security, privacy, and data protection standards required by various regulations. Navigating these requirements is crucial for organizations to avoid legal and financial repercussions and to maintain trust with customers and stakeholders.

Key Aspects of Cloud Compliance and Regulatory Requirements

1. Understanding Relevant Regulations

Organizations must identify which regulations apply based on their industry, geographical location, and the nature of their data.

- **General Data Protection Regulation (GDPR):** Applies to organizations processing personal data of EU residents. It mandates data protection and privacy measures.
- **Health Insurance Portability and Accountability Act (HIPAA):** Governs the protection of health information in the U.S., including data privacy and security requirements for healthcare providers.
- **Payment Card Industry Data Security Standard (PCI-DSS):** Sets standards for protecting payment card information and ensuring secure transactions.
- **California Consumer Privacy Act (CCPA):** Provides privacy rights to California residents and mandates certain data protection practices.

2. Data Residency and Sovereignty

Data Residency and **Data Sovereignty** involve understanding where data is physically stored and ensuring compliance with local laws regarding data storage and processing.

- **Data Residency:** Ensures that data is stored in specific geographic locations as required by laws or regulations.
- **Data Sovereignty:** Addresses the legal jurisdiction and regulatory requirements governing the data based on its physical location.

3. Cloud Provider Compliance

Ensure that cloud service providers (CSPs) comply with relevant regulations and standards.

- **Certifications and Audits:** Verify that CSPs hold relevant certifications (e.g., ISO 27001, SOC 2) and undergo regular security audits.
- **Service-Level Agreements (SLAs):** Review SLAs to ensure they include compliance-related obligations and security controls.

CHAPTER 10

Cloud Forensics and Incident Analysis

Ms.M.Jeeva

Cloud Forensics and Incident Analysis involve the processes and techniques used to investigate, analyze, and respond to security incidents and breaches in cloud environments. Given the distributed and dynamic nature of cloud computing, these activities require specialized approaches and tools to effectively gather evidence, understand the incident, and mitigate its impact.

. Incident Detection and Identification

Incident Detection involves recognizing and confirming that a security incident has occurred.

- **Monitoring Tools:** Use Security Information and Event Management (SIEM) systems and other monitoring tools to detect anomalies and suspicious activities.
- **Alerts and Notifications:** Configure alerts for potential indicators of compromise (IoCs) or unusual behavior that may indicate an incident.

Incident Response

Incident Response is the process of addressing and managing the immediate effects of a security incident to limit damage and prevent further compromise.

- **Incident Response Plan:** Develop a comprehensive incident response plan that outlines roles, responsibilities, and procedures for handling incidents.
- **Containment:** Take steps to contain the incident, such as isolating affected systems or networks to prevent further spread.
- **Eradication:** Remove the root cause of the incident, such as eliminating malware or fixing vulnerabilities.
- **Recovery:** Restore affected systems and services to normal operation, ensuring that they are **secure and not compromised**.

Evidence Collection

Evidence Collection involves gathering and preserving digital evidence related to the incident.

- **Forensic Imaging:** Create forensic images of affected systems, storage devices, or cloud resources to preserve evidence in its original state.
- **Log Collection:** Collect logs from cloud services, applications, and network devices to analyze activities and events related to the incident.
- **Chain of Custody:** Maintain a chain of custody for evidence to ensure its integrity and admissibility in legal proceedings.



SOFTWARE DEFINED NETWORKS

**EDITED BY
N.DHIVYA**



978-93-6255-101-6

SOFTWARE DEFINED NETWORKS

Copyright © 2023 by N.DHIVYA

All rights reserved. No part of this book may be reproduced or transmitted in any form or by any means without written permission from the author.

ISBN: 978-93-6255-101-6

Publisher: PonnaiyahRamajayam Institute of Science and Technology (PRIST)

TABLE OF CONTENTS

| | | |
|---|---|------------|
| Introduction | - | 03 |
| CHAPTER 1 – SDN Data Plane and Control Plane | - | 17 |
| Dr.R.Latha | | |
| CHAPTER 2 – SDN Applications | - | 37 |
| Ms.M.Jeeva | | |
| CHAPTER 3 – Network Function Virtualization | - | 56 |
| Ms.N.Dhivya | | |
| CHAPTER 4 – Southbound APIs and Device Control | - | 67 |
| Dr.R.Latha | | |
| CHAPTER 5 – Traffic Engineering and Optimization | - | 87 |
| Ms.M.Jeeva | | |
| CHAPTER 6 – SDN in Data Centers and Clouds | - | 106 |
| Ms.N.Dhivya | | |
| CHAPTER 7 – SDN Deployment models | - | 117 |
| Dr.R.Latha | | |
| CHAPTER 8 – SDN Network Management | - | 127 |
| Ms.M.Jeeva | | |
| CHAPTER 9 – SDN Troubleshooting and Monitoring | - | 146 |
| Ms.N.Dhivya | | |
| CHAPTER 10 – SDN Tools and Software | - | 176 |
| Ms.N.Dhivya | | |
| REFERENCES | - | 208 |

CHAPTER 1

SDN Data Plane and Control Plane

Dr.R.Latha

In Software-Defined Networking (SDN), the network architecture is divided into distinct layers or planes that handle different aspects of network management and operation. The **Data Plane** and **Control Plane** are two fundamental components of this architecture, each with specific roles and responsibilities.

Data Plane

The **Data Plane** is responsible for the actual transmission of data packets across the network. It handles the forwarding of packets based on the rules defined by the Control Plane.

Key Characteristics

1. **Packet Forwarding:**
 - The Data Plane is primarily concerned with the forwarding of packets from one network device to another. It performs the actual data transfer operations.
2. **Flow Tables:**
 - Network devices, such as switches and routers, use flow tables to make forwarding decisions. These tables contain rules that specify how packets should be handled based on various criteria like source/destination IP addresses, MAC addresses, or other packet fields.
3. **Local Processing:**
 - Decisions on how to handle packets are made locally by the Data Plane. The Data Plane typically does not involve high-level decision-making or policy enforcement.
4. **Low Latency:**
 - The Data Plane operations are designed for high-speed processing and low latency to ensure efficient data transmission.
5. **Data Path Elements:**
 - In SDN, the Data Plane includes network devices like switches and routers that forward data based on the instructions received from the Control Plane.

Control Plane

The **Control Plane** is responsible for making high-level decisions about network traffic, including the configuration of network devices and the establishment of paths for data flow.

Key Characteristics

1. **Network Management:**
 - The Control Plane manages the overall network topology, routing protocols, and traffic engineering. It determines how packets should be routed and handled across the network.

CHAPTER 2

SDN Applications

Ms.M.Jeeva

Software-Defined Networking (SDN) enables a range of applications that leverage its centralized control and programmability to enhance network management, efficiency, and innovation. SDN applications take advantage of the decoupling of the control and data planes to provide advanced networking capabilities and services. Here are some prominent SDN applications:

1. Network Virtualization

Network Virtualization allows multiple virtual networks to be created over a single physical network infrastructure.

- **Virtual LANs (VLANs):** SDN enables the creation and management of VLANs with flexible and dynamic configurations.
- **Network Function Virtualization (NFV):** Virtualizes network functions such as firewalls, load balancers, and intrusion detection systems, allowing them to run as software on standard hardware.

2. Traffic Engineering

Traffic Engineering involves optimizing the flow of network traffic to improve performance and resource utilization.

- **Dynamic Path Selection:** SDN can dynamically reroute traffic based on current network conditions, load balancing, and congestion.
- **Bandwidth Management:** Adjusts bandwidth allocation to ensure efficient use of network resources and to meet service level agreements (SLAs).

3. Network Automation

Network Automation involves automating network management tasks to reduce manual configuration and operational overhead.

- **Provisioning and Orchestration:** Automatically provisions and configures network resources based on predefined policies and requirements.
- **Automated Troubleshooting:** Uses real-time data and analytics to identify and resolve network issues automatically.

4. Security and Policy Enforcement

Security and Policy Enforcement involve implementing and enforcing network security policies and controls.

CHAPTER 3

Network Function Virtualization

Ms.N.Dhivya

Network Function Virtualization (NFV) is a network architecture concept that separates network functions from the hardware they traditionally run on, allowing them to run as software on general-purpose servers. NFV aims to replace proprietary network appliances (like firewalls, load balancers, and routers) with virtualized network functions (VNFs) that run in virtual machines (VMs) or containers.

Decoupling of Functions from Hardware:

- Traditionally, each network function (e.g., firewall, NAT, VPN) required dedicated hardware. NFV decouples these functions from the hardware, enabling them to be deployed as software applications on commodity servers.

Virtual Network Functions (VNFs):

- VNFs are the software-based equivalents of network services that used to run on dedicated hardware appliances. These functions can now run in virtualized environments, providing flexibility in deployment and scaling.

NFV Infrastructure (NFVI):

- The underlying physical hardware and virtualization software that supports the execution of VNFs. It consists of standard computing resources (servers, storage, and networking), providing the foundation for running virtualized services.

Orchestration and Management:

- **NFV Orchestrators** manage the lifecycle of VNFs, from deployment to scaling, upgrading, and decommissioning. This includes automating the creation and management of VNFs across different network environments.

Benefits of NFV

1. Cost Efficiency:

- By using general-purpose hardware instead of proprietary network devices, NFV reduces capital and operational expenses.

2. Flexibility and Agility:

- Network services can be quickly deployed, scaled, or modified as software applications, allowing for dynamic adjustment based on demand.

3. Faster Time-to-Market:

CHAPTER 4

Southbound APIs and Device Control

Dr.R.Latha

Southbound APIs are crucial in Software-Defined Networking (SDN) and Network Function Virtualization (NFV) as they enable communication between the control plane and the data plane, allowing for the management and control of network devices.

Southbound APIs and Device Control

1. Southbound APIs

Southbound APIs are interfaces used by the SDN controller to interact with network devices in the data plane. They enable the control plane to send instructions and configuration updates to devices, as well as receive status and telemetry data.

- **Purpose:** They facilitate the communication between the SDN controller and network devices, allowing for centralized network management and control.
- **Functions:** Southbound APIs are responsible for tasks such as configuring flow tables, managing network traffic, and monitoring device status.

2. Common Southbound APIs

Several Southbound APIs are commonly used in SDN environments, each providing different capabilities and levels of abstraction:

1. OpenFlow

- **Overview:** The most widely used Southbound API in SDN. It defines a protocol for communication between SDN controllers and network switches.
- **Functions:** Allows controllers to manage flow tables in switches, set up packet forwarding rules, and gather statistics.
- **Versioning:** OpenFlow has multiple versions, with each new version introducing enhancements and additional features.

2. NETCONF (Network Configuration Protocol)

- **Overview:** A protocol for managing and configuring network devices using XML-based data models.
- **Functions:** Provides capabilities for configuration, monitoring, and management of network devices. Often used in conjunction with YANG data models.

3. REST APIs

- **Overview:** RESTful APIs are used for web-based communication and provide a simple, HTTP-based interface for interacting with network devices.
- **Functions:** Commonly used for device management, configuration, and monitoring through standard HTTP methods (GET, POST, PUT, DELETE).

4. SNMP (Simple Network Management Protocol)

- **Overview:** An older protocol used for managing and monitoring network devices.

CHAPTER 5

Traffic Engineering and Optimization

Ms.M.Jeeva

Traffic Engineering and Optimization are critical aspects of network management that focus on efficiently managing and directing network traffic to ensure optimal performance, reliability, and resource utilization. In the context of Software-Defined Networking (SDN) and Network Function Virtualization (NFV), these concepts are enhanced through centralized control and advanced network programmability.

Traffic Engineering

Traffic Engineering (TE) involves managing and directing network traffic to optimize the performance and utilization of network resources. The goal is to ensure that network traffic is distributed efficiently to avoid congestion, reduce latency, and maximize throughput.

Key Techniques in Traffic Engineering

1. Traffic Distribution

- **Load Balancing:** Distributes traffic across multiple paths or resources to prevent any single path from becoming overloaded. Techniques include equal-cost multi-path (ECMP) routing and dynamic load balancing.
- **Path Selection:** Chooses the most efficient path for traffic based on network conditions, such as bandwidth availability and latency.

2. Bandwidth Management

- **Bandwidth Allocation:** Allocates bandwidth to different traffic flows based on priorities or service level agreements (SLAs). Techniques include traffic shaping and policing.
- **Congestion Control:** Implements mechanisms to control and alleviate congestion, such as buffering and traffic rerouting..

3. Traffic Engineering in SDN

- **Centralized Control:** SDN controllers can optimize traffic engineering by having a global view of the network and dynamically adjusting flow rules based on real-time data.
- **Programmable Routing:** Allows for the implementation of custom routing algorithms and policies that can adapt to changing traffic conditions.

Optimization

Optimization in networking refers to enhancing various aspects of network performance to achieve the best possible outcomes in terms of speed, efficiency, and resource utilization.

Key Optimization Strategies

1. Network Utilization

- **Resource Allocation:** Optimizes the allocation of network resources, such as bandwidth, processing power, and storage, to ensure efficient usage and avoid bottlenecks.

CHAPTER 6

SDN in Data Centers and Clouds

Ms.N.Dhivya

SDN in Data Centers

Data centers are facilities that house computing resources, including servers, storage, and networking equipment, to provide services and applications to users. SDN introduces several benefits and capabilities for managing these environments.

Key Benefits of SDN in Data Centers

1. Centralized Network Management

- **Unified Control:** SDN allows for centralized management of network resources, providing a single interface for configuring and monitoring network devices. This simplifies operations and reduces the complexity of managing large-scale data center networks.

2. Enhanced Network Flexibility

- **Dynamic Provisioning:** SDN enables dynamic provisioning of network resources and services based on real-time demand. This allows for quick adaptation to changing workloads and application requirements.
- **Customizable Network Topologies:** Network topologies can be easily reconfigured to optimize performance or support new services without requiring physical changes to the infrastructure.

3. Improved Scalability

- **Elastic Scaling:** SDN facilitates the elastic scaling of network resources, allowing data centers to efficiently handle varying workloads and scale up or down as needed.
- **Automated Configuration:** Automated configuration and provisioning reduce the time and effort required to scale network resources, improving overall scalability.

4. Optimized Resource Utilization

- **Traffic Optimization:** SDN provides tools for optimizing traffic distribution and load balancing across the data center network, enhancing performance and resource utilization.
- **Cost Efficiency:** By consolidating network management and reducing reliance on specialized hardware, SDN can lead to cost savings in terms of both capital and operational expenses.

5. Enhanced Security and Compliance

- **Segmentation and Isolation:** SDN enables micro-segmentation and network isolation to enhance security by segmenting traffic and enforcing policies at a granular level.
- **Policy Enforcement:** Centralized policy enforcement ensures consistent security measures and compliance with regulatory requirements.

CHAPTER 7

SDN Deployment models

Dr.R.Latha

Software-Defined Networking (SDN) deployment models define how SDN principles and technologies are integrated into various network environments. The choice of deployment model impacts the level of control, flexibility, and management capabilities available within the network infrastructure. Here are the primary SDN deployment models:

1. Overlay SDN

Overlay SDN involves creating virtual networks (overlays) on top of existing physical network infrastructure. This model abstracts the underlying hardware and allows for the creation of virtual networks with customized configurations and policies.

- **Characteristics:**
 - **Virtualization:** Overlays are created using virtualization technologies such as Virtual LANs (VLANs), Virtual Extensible LANs (VXLANs), or Generic Network Virtualization Encapsulation (GENEVE).
 - **Isolation:** Provides network isolation for different tenants or applications, allowing for multi-tenancy and improved security.
 - **Flexibility:** Allows for dynamic and flexible network configurations without modifying the underlying physical network.
- **Use Cases:**
 - **Data Center Virtualization:** Virtual networks for different applications or tenants within a data center.
 - **Multi-Tenant Environments:** Supporting multiple tenants in a cloud or hosting environment.

2. Underlay SDN

Underlay SDN focuses on the physical network infrastructure and involves directly managing and controlling network hardware. This model provides a foundational layer for overlay networks and ensures efficient and reliable connectivity.

- **Characteristics:**
 - **Direct Control:** Provides direct control over physical network devices such as switches, routers, and links.
 - **Performance:** Optimizes the performance of the physical network through techniques such as load balancing and traffic engineering.
 - **Simplification:** Simplifies the management of physical infrastructure by centralizing control and automating network operations.
- **Use Cases:**
 - **Data Center Networking:** Managing and optimizing the physical network within data centers.

CHAPTER 8

SDN Network Management

Ms.M.Jeeva

SDN Network Management refers to the process of overseeing and controlling network resources and services using Software-Defined Networking (SDN) principles and technologies. It involves configuring, monitoring, and optimizing network infrastructure through a centralized control plane, which allows for enhanced flexibility, automation, and efficiency.

Key Components of SDN Network Management

1. SDN Controller

- **Role:** Acts as the central management entity that communicates with network devices through Southbound APIs. The controller makes decisions about network behavior, configurations, and policies.
- **Functions:** Manages network topology, configures flow tables, enforces policies, and orchestrates network services.

2. Southbound APIs

- **Role:** Facilitate communication between the SDN controller and network devices. They allow the controller to configure and manage network hardware.
- **Examples:** OpenFlow, NETCONF, REST APIs.

Functions of SDN Network Management

1. Configuration Management

- **Network Provisioning:** Automates the deployment and configuration of network devices and services, including setting up virtual networks and applying policies.
- **Policy Enforcement:** Implements and enforces network policies such as QoS, security rules, and traffic management.

2. Monitoring and Analytics

- **Performance Monitoring:** Continuously tracks network performance metrics, such as bandwidth usage, latency, and packet loss.
- **Traffic Analysis:** Analyzes traffic patterns and flows to identify bottlenecks, optimize
- **Access Control:** Manages user access and permissions for network resources an.

Benefits of SDN Network Management

1. Centralized Control

- Provides a single point of control for managing and configuring the entire network, simplifying operations and reducing complexity.

2. Flexibility and Agility

- Enables dynamic and flexible network configurations, allowing for rapid adjustments based on changing requirements and conditions

CHAPTER 9

SDN Troubleshooting and Monitoring

Ms.N.Dhivya

SDN Troubleshooting and Monitoring are crucial aspects of maintaining and optimizing a Software-Defined Networking (SDN) environment. These processes ensure that the network operates smoothly, issues are quickly identified and resolved, and overall performance is maximized. Here's a comprehensive overview of SDN troubleshooting and monitoring:

SDN Troubleshooting

SDN Troubleshooting involves identifying, diagnosing, and resolving issues within an SDN environment. This process is essential for maintaining network reliability and performance.

Key Components of SDN Troubleshooting

1. Issue Identification

- **Symptom Detection:** Recognize symptoms of network issues such as performance degradation, connectivity problems, or unexpected behavior.
- **Alerting:** Use monitoring tools to generate alerts for anomalies or failures. Alerts can be based on predefined thresholds or detected patterns.

2. Diagnostic Tools and Techniques

- **Flow Tables Analysis:** Examine flow tables in network devices to understand how traffic is being handled and identify discrepancies or misconfigurations.
- **Packet Capture and Analysis:** Use tools to capture and analyze network traffic, which can help in understanding the flow of data and identifying issues such as packet loss or misrouting.
- **Logs and Metrics:** Review logs and performance metrics from the SDN controller and network devices to gather information about network operations and identify potential problems.

3. Root Cause Analysis

- **Correlation of Data:** Correlate data from various sources, such as logs, metrics, and packet captures, to determine the underlying cause of an issue.
- **Scenario Testing:** Simulate different scenarios or conditions to reproduce and isolate the issue, aiding in accurate diagnosis.

4. Resolution

- **Configuration Adjustments:** Modify network configurations or policies to address identified issues. This may involve updating flow rules, adjusting bandwidth allocations, or correcting misconfigurations.
- **Software Updates:** Apply patches or updates to the SDN controller or network devices if the issue is related to software bugs or vulnerabilities.

5. Documentation and Review

- **Issue Documentation:** Record details about the issue, including symptoms, diagnosis, resolution, and any changes made.

CHAPTER 10

SDN Tools and Software

Ms.N.Dhivya

SDN Tools and Software are essential for managing, configuring, and optimizing Software-Defined Networking (SDN) environments. These tools support various aspects of SDN, including network control, automation, monitoring, and troubleshooting. Here's an overview of the key tools and software commonly used in SDN deployments:

1. SDN Controllers

SDN controllers are the central components of SDN architectures, providing a unified control plane for managing network devices and services.

- **OpenDaylight**
 - **Description:** An open-source SDN controller that supports multiple protocols and provides extensive customization capabilities.
 - **Features:** Modular architecture, support for various southbound protocols (e.g., OpenFlow), extensive northbound APIs, and strong community support.
- **ONOS (Open Network Operating System)**
 - **Description:** An open-source SDN controller designed for high-performance and scalable network management.
 - **Features:** High availability, scalability, support for network virtualization, and integration with various network applications.
- **Ryu**
 - **Description:** A lightweight and flexible SDN controller written in Python.
 - **Features:** Simple API for network applications, support for OpenFlow and other southbound protocols, and extensibility.
- **Cisco APIC-EM**
 - **Description:** Cisco's SDN controller for managing and automating Cisco network devices.
 - **Features:** Policy-based automation, network assurance, and analytics.

2. Network Virtualization and Orchestration Tools

These tools support the creation and management of virtual networks and services.

- **VMware NSX**
 - **Description:** A network virtualization platform that provides network and security services for virtualized environments.
 - **Features:** Network segmentation, micro-segmentation, automated network provisioning, and integration with VMware's ecosystem.
- **OpenStack Neutron**
 - **Description:** The networking component of OpenStack that provides network connectivity and services in a cloud environment.

STORAGE TECHNOLOGIES

EDITED BY

V.GAYATHIRI



978-93-6255-270-9

STORAGE TECHNOLOGIES

Copyright © 2023 by V.Gayathiri

All rights reserved. No part of this book may be reproduced or transmitted in any form or by any means without written permission from the author.

ISBN: 978-93-6255-270-9

Publisher: Ponnaiyah Ramajayam Institute of Science and Technology (PRIST)

TABLE OF CONTENTS

| | | |
|---|---|------------|
| Introduction | - | 03 |
| CHAPTER 1 – Storage System | - | 15 |
| Ms.M.Mohana Priya | | |
| CHAPTER 2 – Intelligent Systems and Raid | - | 40 |
| Ms.S.Gayathiri | | |
| CHAPTER 3 – Storage Networking Technologies and Virtualization | - | 73 |
| Dr. R.Latha | | |
| CHAPTER 4 – Backup,Archive and Application | - | 120 |
| Dr.R.Latha | | |
| CHAPTER 5 – Disk Drive Data Placement and Scheduling | - | 140 |
| Ms.M.Mohana Priya | | |
| CHAPTER 6 – Mirrored & Hybrid Array | - | 153 |
| Ms.M.Jeeva | | |
| CHAPTER 7 – Coding for Multiple Disk Failures | - | 169 |
| Ms.S.Gayathiri | | |
| CHAPTER 8 – Database parallelism,Big Data Analytics, Deep Learning | - | 184 |
| Dr. R.Latha | | |
| CHAPTER 9 – Heterogenous Disk Arrays - HDAs | - | 210 |
| Ms.M.Jeeva | | |
| CHAPTER 10 – Hierarchical RAID - HRAID | - | 240 |
| Ms.M.Mohana Priya | | |
| REFERENCES | - | 254 |

CHAPTER 1

Storage System

Ms.M.Mohana Priya

A storage system is a collection of hardware and software resources designed to store, manage, and retrieve data. These systems range from simple external hard drives to complex, distributed storage networks. The choice of a storage system depends on factors such as capacity, performance, cost, scalability, and redundancy.

Types of Storage Systems

- **Direct-Attached Storage (DAS):**
 - Physically connected to a computer or server (e.g., internal/external hard drives).
- **Network-Attached Storage (NAS):**
 - Connects to a network and allows multiple users and devices to access files over a network.
- **Storage Area Network (SAN):**
 - A high-speed network that provides block-level storage to multiple servers.
- **Object Storage:**
 - Stores data as objects rather than files or blocks, along with metadata..

Key Components of Storage Systems

- **Storage Devices:**
 - Hard Disk Drives (HDDs) and Solid-State Drives (SSDs) are the primary storage devices.
 - HDDs offer higher capacities at lower costs but slower speeds.
 - SSDs provide faster access times and are more reliable but are more expensive per GB.
- **RAID (Redundant Array of Independent Disks):**
 - A technology used to combine multiple disks into a single unit for redundancy or performance improvement.
 - Common RAID levels include RAID 0 (striping), RAID 1 (mirroring), RAID 5 (striping with parity), and RAID 6 (dual parity).

Storage Protocols

- **Fibre Channel (FC):**
 - A high-speed networking technology used primarily for SANs.
 - Provides fast, reliable data transfer with low latency.
- **iSCSI (Internet Small Computer Systems Interface):**
 - Allows SCSI commands to be transmitted over IP networks.
 - Provides a cost-effective alternative to Fibre Channel for SANs.

- **NFS (Network File System) and SMB (Server Message Block):**
 - Protocols used for NAS systems to provide file access over a network.

CHAPTER 2

Intelligent Systems and Raid

Ms.S.Gayathiri

Intelligent Storage Systems are advanced storage solutions that incorporate built-in intelligence to manage, optimize, and protect data storage. These systems typically include features like automated tiering, data deduplication, compression, caching, and predictive analytics to enhance performance, reliability, and efficiency.

Benefits of Intelligent Storage Systems:

- **Improved Performance:** Faster data access through caching and tiering.
- **Cost Efficiency:** Optimizes storage resources, reducing both CAPEX and OPEX.
- **Simplified Management:** Automated features reduce the need for manual intervention.

RAID (Redundant Array of Independent Disks)

RAID is a technology that combines multiple physical disk drives into a single logical unit to improve performance, redundancy, or both. RAID uses different levels to provide various balances of performance, storage capacity, and fault tolerance.

Key RAID Levels:

1. **RAID 0 (Striping):**
 - Distributes data across multiple disks to improve read and write speeds.
 - No redundancy; if one disk fails, all data is lost.
 - Suitable for non-critical applications where speed is a priority (e.g., video editing).
2. **RAID 1 (Mirroring):**
 - Duplicates the same data onto two or more disks.
 - Provides redundancy; data is still available if one disk fails.
 - Suitable for critical applications where data availability is essential (e.g., databases).
3. **RAID 5 (Striping with Parity):**
 - Combines striping with parity (error-checking data) distributed across all disks.
 - Provides redundancy with a minimum of three disks; can tolerate the failure of one disk.
 - Offers a balance between performance, storage efficiency, and fault tolerance.
 - Commonly used in enterprise environments for file and application servers.
4. **RAID 6 (Striping with Dual Parity):**
 - Similar to RAID 5 but with two parity blocks, allowing for the failure of two disks.

- Requires a minimum of four disks.
- Provides higher fault tolerance than RAID 5, but with slightly reduced write performance.

CHAPTER 3

Storage Networking Technologies and Virtualization

Dr. R.Latha

Storage networking technologies and virtualization are critical components of modern data centers, enabling efficient data management, scalability, and flexibility. These technologies help in connecting storage resources with servers and optimizing storage usage through abstraction.

Storage Networking Technologies

Storage networking technologies provide the infrastructure to connect storage devices (like SAN and NAS) to servers and clients over a network. The primary goal is to provide scalable, high-performance, and reliable access to storage resources.

Benefits of Storage Networking Technologies:

- **Improved Performance:** High-speed, low-latency access to storage resources.
- **Scalability:** Easily scale storage resources to accommodate growth.
- **Centralized Management:** Easier to manage and allocate storage resources.
- **Data Protection:** Supports advanced features like replication, snapshots, and backups.

Storage Virtualization

Storage virtualization is a technology that abstracts and pools physical storage resources from multiple devices into a single logical storage resource, which can then be managed centrally. It decouples storage from the physical hardware, providing flexibility, efficiency, and simplified management.

Types of Storage Virtualization:

1. **Block-Level Virtualization:**
 - Abstracts the physical storage blocks and presents them as logical volumes to the host systems.
 - Commonly used in SAN environments to create virtual storage pools that can be dynamically allocated to different servers.
 - Provides flexibility in storage management, such as resizing volumes, creating snapshots, and migrating data without disruption.
2. **File-Level Virtualization:**
 - Abstracts file storage and presents it as a unified file system.

- Commonly used in NAS environments to provide a single namespace for multiple file systems across different storage devices.
- Simplifies data management by providing a consistent view of data, regardless of its physical location.

CHAPTER 4

Backup, Archive and Application

Dr. R.Latha

Backup and archiving are two key strategies for managing and protecting data, while applications are the tools and software that use or manage this data. Understanding these concepts is crucial for ensuring data availability, recovery, and compliance with regulations.

Backup

A **backup** is a copy of data created to recover and restore information in case of data loss, corruption, or disaster. Backups are critical for business continuity and disaster recovery.

Types of Backup:

1. **Full Backup:**
 - Backs up all data in the system, including files, applications, and settings.
 - Provides a complete copy of the data, which simplifies the restoration process.
 - Requires the most time and storage space but is the most comprehensive type of backup.
2. **Incremental Backup:**
 - Only backs up the data that has changed or been added since the last backup (either full or incremental).
 - Requires less storage space and time compared to a full backup.

Backup Strategies:

- **3-2-1 Rule:**
 - Keep three copies of data (production copy and two backups).
 - Store backups on two different types of media (e.g., disk and tape).
- **On-Premises Backup:**
 - Backups are stored locally within the organization's data center.
 - Provides faster backup and restore times but is vulnerable to physical disasters affecting the site.

Archive

An **archive** is a long-term storage solution for data that is no longer actively used but needs to be retained for compliance, reference, or historical purposes. Unlike backups, archives are not intended for immediate recovery but for long-term retention and access.

Application Backup and Archiving

Applications often require specialized backup and archiving strategies due to their specific data structures, performance requirements, and dependencies.

CHAPTER 5

Disk Drive Data Placement and Scheduling

Dr. R.Latha

Disk drive data placement and scheduling are crucial aspects of storage system design that influence performance, reliability, and efficiency. Proper placement and scheduling help in optimizing disk I/O (Input/Output) operations, reducing latency, and maximizing throughput.

Disk Drive Data Placement

Data placement refers to the strategy used to store data blocks on a disk drive. Efficient data placement aims to minimize seek time, rotational latency, and optimize data access patterns.

Key Concepts in Data Placement:

1. Cylinder, Track, and Sector:

- Cylinder: A set of tracks that are aligned vertically across multiple platters of a disk drive.
- Track: A concentric circle on the disk platter that stores data.
- Sector: The smallest storage unit on a track, typically 512 bytes or 4096 bytes in size.
- Data is stored in sectors, which are organized into tracks and grouped into **cylinders.**

2. Sequential Data Placement:

- Stores data blocks sequentially on the disk.
- Reduces seek time by minimizing the distance the read/write head must travel between blocks.
- Ideal for workloads with large, contiguous read or write operations (e.g., video streaming or backup).

3. Random Data Placement:

- Data blocks are distributed randomly across the disk surface.
- Increases seek time and latency but can be beneficial in scenarios where data access patterns are unpredictable.
- Commonly seen in general-purpose computing environments where workloads **are mixed.**

4. Clustered Data Placement:

- Groups related data blocks together on the disk.

- Reduces the seek time for related data, improving performance for applications that frequently access related data (e.g., databases).
 - Often implemented in RAID (Redundant Array of Independent Disks) configurations to improve fault tolerance and performance.
5. **Hot and Cold Data Placement:**
- Hot Data: Frequently accessed or modified data is placed in faster, more accessible areas of the disk.
 - Cold Data: Infrequently accessed data is stored in less accessible areas of the disk.

CHAPTER 6

Mirrored & Hybrid Array

Dr. R.Latha

Mirrored Arrays and **Hybrid Arrays** are two types of storage configurations that offer different benefits based on performance, redundancy, and cost-efficiency. Understanding these arrays is essential for designing storage solutions that meet specific workload requirements and organizational needs.

Mirrored Array

A **mirrored array** is a type of storage configuration that creates an exact copy (mirror) of data on two or more disks. This setup is primarily used to ensure data redundancy and protect against data loss in case of disk failure.

Advantages of Mirrored Arrays:

- **Data Redundancy:** High level of fault tolerance; data remains intact even if a disk fails.
- **Improved Read Performance:** Multiple disks can handle read requests, improving read speed.
- **Simple to Implement:** Easy to set up and manage compared to more complex RAID configurations.

Hybrid Array

A **hybrid array** combines two or more types of storage media (typically solid-state drives (SSDs) and hard disk drives (HDDs)) within a single storage system. This approach aims to balance the performance of SSDs with the cost-effectiveness and high capacity of HDDs.

Hybrid Array Configurations:

1. **Dynamic Storage Tiering:**
 - Automatically moves data between storage tiers based on usage patterns.
 - Frequently accessed data is promoted to SSDs, while infrequently accessed data is demoted to HDDs.

- Optimizes performance and storage efficiency without manual intervention.
- 2. **Read/Write Caching:**
 - SSDs are used as a cache layer for both read and write operations.
 - Frequently read data is cached on SSDs to improve read speeds.

Flash-Optimized Hybrid Arrays:

- Optimized for high-performance workloads, with a larger proportion of SSDs relative to HDDs.

CHAPTER 7

Coding for Multiple Disk Failures

Ms.S.Gayathiri

To enhance data reliability and availability, storage systems use various coding techniques to protect against multiple disk failures. These techniques ensure that data can be reconstructed even when more than one disk fails, providing higher fault tolerance than simple mirroring or parity methods.

Introduction to Coding for Multiple Disk Failures

When designing storage systems, the primary goal is to maintain data integrity and availability, even in the event of disk failures. Traditional RAID (Redundant Array of Independent Disks) configurations like RAID 1 (mirroring) or RAID 5 (single-parity) can only protect against single disk failures. To handle multiple disk failures, more advanced coding methods such as **RAID 6**, **erasure coding**, and **advanced XOR-based algorithms** are used.

Techniques for Handling Multiple Disk Failures

RAID 6 (Double Parity RAID)

RAID 6 provides protection against up to two simultaneous disk failures by using two independent parity blocks.

- **Data and Parity Layout:**
 - Data blocks are distributed across multiple disks.
 - Two parity blocks are created for every stripe of data.

Advantages:

- Protects against two simultaneous disk failures.
- Relatively simple to implement and widely supported by hardware and software RAID controllers.

Erasure Coding

Erasure Coding is a more advanced method of coding that protects against multiple disk failures by dividing data into chunks and encoding them with redundancy blocks. It generalizes the concept of RAID 6 to provide even greater fault tolerance.

Advanced XOR-Based Coding Techniques

Advanced XOR-based coding techniques are optimized for low computational overhead and reduced storage space, focusing on environments where read and write performance are critical.

CHAPTER 8

Database parallelism, Big Data Analytics, Deep Learning

Dr. R.Latha

Database Parallelism

Database parallelism involves dividing database operations into smaller tasks that can be executed simultaneously (in parallel) to improve performance, especially for large-scale data processing.

Techniques to Implement Database Parallelism:

- **Partitioning:**
 - Divides data into smaller, more manageable pieces (partitions) that can be processed independently.
 - Types of partitioning include **horizontal** (row-based) and **vertical** (column-based) partitioning.
- **Pipelining:**
 - Sends the output of one operation directly to the next operation without intermediate storage.
 - Reduces I/O wait times and speeds up overall processing.
- **Parallel Query Execution:**
 - Uses multiple processing units (CPUs or nodes) to execute different parts of a query simultaneously.
 - Common in distributed database systems like **Apache Hadoop**, **Apache Spark**, and **Google BigQuery**.

Big Data Analytics

Big Data Analytics refers to the process of examining large and complex datasets to uncover hidden patterns, correlations, and insights that can help organizations make better decisions.

Key Components of Big Data Analytics:

1. **Data Storage and Management:**
 - Big data often involves data storage solutions like **Hadoop Distributed File System (HDFS)**, **NoSQL databases** (e.g., MongoDB, Cassandra), and **data lakes**.

- Storage must handle high-velocity data with scalable capacity and efficient retrieval capabilities.
- 2. **Data Processing Frameworks:**
 - **Batch Processing:** Processes large volumes of data in bulk (e.g., Apache Hadoop, Apache Hive).

Deep Learning

Deep Learning is a subset of machine learning that uses neural networks with many layers (deep neural networks) to model complex patterns in large datasets.

CHAPTER 9

Heterogenous Disk Arrays - HDAs

Ms.M.Jeeva

Heterogeneous Disk Arrays (HDAs) refer to storage architectures that combine different types of disk drives within the same storage array. Unlike traditional homogeneous disk arrays, which use identical disks (in terms of capacity, speed, and technology), HDAs leverage a mix of various disk types to optimize performance, cost, and capacity.

Key Components of Heterogeneous Disk Arrays

1. **Disk Types:**
 - **Hard Disk Drives (HDDs):** Used for high-capacity, low-cost storage. Ideal for sequential read/write operations and archival data.
 - **Solid State Drives (SSDs):** Used for high-performance, low-latency storage. Suitable for
2. **Storage Tiers:**
 - **Tiered Storage:** Divides storage into tiers based on performance and cost, using faster, more expensive disks (like SSDs) for frequently accessed data, and slower, cheaper disks (like HDDs) for less frequently accessed data.
 - **Hot, Warm, and Cold Storage Tiers:**
 - **Hot Tier:** High-speed SSDs or NVMe drives for critical data requiring low latency and high throughput.
 - **Warm Tier:** Lower-speed SSDs or high-performance HDDs for data that is less frequently accessed but still needs reasonable performance.
 - **Cold Tier:** High-capacity HDDs for archival and backup data that are rarely accessed.
3. **Storage Controllers and Management Software:**
 - **Intelligent Storage Controllers:** Manage data placement across different types of disks, handle I/O requests, and optimize data flow.
 - **Data Management Software:** Tools that provide automated tiering, data migration, load balancing, and caching to optimize performance and cost.

Benefits of Heterogeneous Disk Arrays

1. **Cost Efficiency:**
 - Reduces overall storage costs by combining high-performance SSDs with lower-cost HDDs. Frequently accessed data is stored on faster disks, while infrequently accessed data is kept on cheaper, higher-capacity disks.
2. **Performance Optimization:**
 - Enhances performance by matching different storage tiers to specific workloads. Critical applications and frequently accessed data can be stored on faster SSDs or NVMe drives, while less demanding applications use HDDs.

CHAPTER 10

Hierarchical RAID - HRAID

Ms.M.Mohana Priya

HRAID is a storage architecture that integrates multiple RAID levels into a single system, with different RAID levels applied to different parts of the storage array. This hierarchical approach aims to balance performance, capacity, and redundancy.

- **Purpose:**
 - To enhance storage system performance by using appropriate RAID levels for different types of data or workloads.
 - To provide a cost-effective solution by combining high-performance RAID levels (e.g., RAID 0 or RAID 5) with high-redundancy RAID levels (e.g., RAID 6 or RAID 10).
 - To achieve flexible data protection and scalability.

Key Components of Hierarchical RAID

1. **RAID Levels in HRAID:**
 - **RAID 0 (Striping):** Provides high performance by dividing data into stripes across multiple disks. Used in HRAID for workloads requiring high throughput.
 - **RAID 1 (Mirroring):** Offers high redundancy by duplicating data across multiple disks. Used in HRAID for critical data that requires maximum protection.
 - **RAID 5 (Striped with Parity):** Balances performance and redundancy with data striped across disks and parity information distributed. Suitable for general-purpose storage.
 - **RAID 6 (Double Parity):** Provides additional fault tolerance with two parity blocks. Ideal for environments requiring high data protection.
 - **RAID 10 (Striped Mirrors):** Combines mirroring and striping for high performance and redundancy. Useful for applications needing both speed and fault tolerance.
2. **Hierarchical Architecture:**
 - **Primary RAID Level:** The top-level RAID configuration that may apply to the entire storage array or a significant portion of it.
 - **Secondary RAID Levels:** Additional RAID levels applied to subsets of disks within the primary RAID configuration or to specific data types.

Implementing Hierarchical RAID

1. Design Considerations:

- **Workload Analysis:** Determine the performance, redundancy, and capacity needs for different types of data or applications.
- **Data Classification:** Identify data that requires high-speed access, high redundancy, or a balance of both. For example, frequently accessed data might use RAID 10, while less critical data might use RAID 5.

2. Common Configurations:

- **RAID 0 on Top of RAID 5 or RAID 6:** Combines the high performance of RAID 0 with the redundancy of RAID 5 or RAID 6. For instance, RAID 5 arrays can be striped using RAID 0 to increase performance.



DATA WAREHOUSING

Edited by

M.MOHANA PRIYA



978-93-6255-857-2

DATA WAREHOUSING

Copyright © 2023 by M.MOHANA PRIYA

All rights reserved. No part of this book may be reproduced or transmitted in any form or by any means without written permission from the author.

ISBN: 978-93-6255-857-2

Publisher: Ponnaiyah Ramajayam Institute of Science and Technology (PRIST)

TABLE OF CONTENTS

| | | |
|---|---|------------|
| Introduction | - | 03 |
| CHAPTER 1 – Introduction to Data Warehouse | - | 16 |
| Ms.M.Mohana Priya | | |
| CHAPTER 2 – Data Warehouse Architecture | - | 36 |
| Ms.K.Sangeetha | | |
| CHAPTER 3 – Data Warehousing Logical Design | - | 57 |
| Dr. R.Latha | | |
| CHAPTER 4 – Design Concepts in Star Schems | - | 75 |
| Ms.M.Jeeva | | |
| CHAPTER 5 – ETL6 and OIAP Technologies | - | 112 |
| Ms.M.Mohana Priya | | |
| CHAPTER 6 – Data Warehousing Physical Design | - | 124 |
| Ms.M.Jeeva | | |
| CHAPTER 7 – Transportation in Data Warehouse | - | 146 |
| Ms.S.Gayathiri | | |
| CHAPTER 8 – Meta Data,Data Mart and Partition Startegy | - | 168 |
| Mr.K.Balamurali | | |
| CHAPTER 9 – Dimensional Model and Schema | - | 180 |
| Mr.M.Balamurali | | |
| CHAPTER 10 – System and Process Management | - | 217 |
| Ms.M.Mohana Priya | | |
| REFERENCES | - | 234 |

CHAPTER 1

Introduction to Data Warehouse

Ms.M.Mohana Priya

Data warehousing is a process of collecting, storing, and managing large volumes of data from various sources to support business intelligence, reporting, and data analysis. A data warehouse is a centralized repository that consolidates data from multiple sources, enabling organizations to perform complex queries, generate reports, and make data-driven decisions.

Data Warehouse:

- **Definition:** A data warehouse is a large, centralized repository designed to store historical and current data from various sources in a structured format for analysis and reporting.
- **Purpose:** To provide a unified view of data, support complex queries, and facilitate decision-making through business intelligence (BI) tools.

Data Mart:

- **Definition:** A subset of a data warehouse, often focused on a specific business area or department (e.g., sales, finance).
- **Purpose:** To provide tailored data and reports for specific user groups, improving performance and relevance.

ETL (Extract, Transform, Load):

- **Definition:** A process used to extract data from source systems, transform it into a suitable format, and load it into the data warehouse.
- **Components:**
 - **Extract:** Pull data from various source systems (databases, files, etc.).
 - **Transform:** Cleanse, filter, and format data to ensure consistency and quality.
 - **Load:** Insert transformed data into the data warehouse.

Data Integration:

- **Definition:** The process of combining data from different sources to provide a unified view.
- **Techniques:** Data integration can be achieved through ETL processes, data virtualization, and data federation.

Dimensional Modeling:

- **Definition:** A design methodology used to structure data in a data warehouse to optimize query performance and ease of use.

CHAPTER 2

Data Warehouse Architecture

Ms.K.Sangeetha

Data warehouse architecture is the blueprint that defines how data is collected, stored, and accessed within a data warehouse environment. It encompasses the components and processes involved in managing and utilizing data for business intelligence and analytics. A well-designed architecture ensures efficient data integration, storage, and retrieval, enabling effective decision-making and reporting.

Data Sources:

- **Definition:** The various systems and databases from which data is extracted. These can include transactional databases, CRM systems, ERP systems, and external data sources.
- **Types:**
 - **Operational Databases:** Databases used for day-to-day operations (e.g., sales, inventory).
 - **External Data Sources:** Data from external providers, such as market research or social media.

Staging Area:

- **Definition:** A temporary storage area where data is collected, cleaned, and transformed before being loaded into the data warehouse.
- **Purpose:** To prepare data for loading by performing initial processing, such as data extraction, transformation, and cleansing.

Data Warehouse:

- **Definition:** The central repository where data is stored in a structured format for analysis and reporting.
- **Structure:**
 - **Data Storage:** Organized into schemas, tables, and partitions to optimize query performance and data management.
 - **Historical Data:** Stores historical data for trend analysis and long-term reporting.

Data Marts:

- **Definition:** Subsets of the data warehouse focused on specific business areas or departments (e.g., sales, finance).
- **Purpose:** To provide tailored data and reports for specific user groups, improving performance and relevance.

CHAPTER 3

Data Warehousing Logical Design

Dr. R.Latha

Logical design in data warehousing involves creating a conceptual framework for how data will be structured and accessed in the data warehouse. It focuses on defining the data relationships, dimensions, facts, and schema design without considering physical implementation details. The goal is to design a data model that supports efficient querying, reporting, and analysis.

Fact Tables:

- **Definition:** Central tables in a data warehouse schema that store quantitative data (measures) such as sales revenue, quantities sold, or profit margins.
- **Characteristics:**
 - **Measures:** Numeric values that represent business metrics (e.g., total sales, average order value).
 - **Keys:** Foreign keys that link to dimension tables.

Dimension Tables:

- **Definition:** Tables that store descriptive attributes related to the measures in fact tables. They provide context and meaning to the data.
- **Examples:** Time, Product, Customer, Location.
- **Attributes:** Fields that describe dimensions (e.g., product name, customer address).

Star Schema:

- **Definition:** A schema design that uses a central fact table connected to multiple dimension tables. It resembles a star, with the fact table at the center.
- **Benefits:** Simplifies queries and improves performance by reducing the complexity of joins.
- **Example:**
 - **Fact Table:** Sales
 - **Dimension Tables:** Time, Product, Customer, Store

Snowflake Schema:

- **Definition:** A variation of the star schema where dimension tables are normalized into multiple related tables. This design resembles a snowflake.

Degenerate Dimension:

- **Definition:** A dimension that does not have its own dimension table but is included as an attribute in the fact table

CHAPTER 4

Design Concepts in Star Schems

Ms.M.Jeeva

Star schema is a widely used design methodology in data warehousing and multidimensional databases. It organizes data into fact and dimension tables to optimize query performance and facilitate analytical processing. The design resembles a star, with the central fact table connected to multiple dimension tables.

Star Schema Design:

- **Structure:** The schema features a central fact table connected to multiple dimension tables, forming a star-like shape.
- **Example:**
 - **Fact Table:** Sales
 - **Measures:** Total Sales, Quantity Sold
 - **Foreign Keys:** Product_ID, Customer_ID, Time_ID
 - **Dimension Tables:**
 - **Product:** Product_ID, Product_Name, Category, Manufacturer
 - **Customer:** Customer_ID, Customer_Name, Address, City, State
 - **Time:** Time_ID, Date, Month, Quarter, Year

Design Considerations in Star Schema

1. **Denormalization:**
 - **Definition:** The process of reducing the complexity of database tables by combining related attributes into a single table.
 - **Purpose:** Star schemas use denormalized dimension tables to simplify queries and improve performance. This denormalization reduces the need for complex joins.
2. **Simplicity:**
 - **Design Goal:** Star schemas aim for simplicity by keeping the design straightforward, with a single fact table and dimension tables. This simplicity makes it easier for users to understand and query the data.
3. **Query Performance:**
 - **Optimization:** Star schemas are designed to optimize query performance by minimizing the number of joins required. The direct relationships between the fact table and dimension tables facilitate faster data retrieval.

Granularity:

- **Definition:** The level of detail captured in the fact table. Granularity affects the volume of data and the type of analysis that can be performed.
- **Consideration:** Choose an appropriate granularity based on reporting and analysis requirements. Finer granularity captures more detail but increases data volume.

CHAPTER 5

ETL6 and OLAP Technologies

Ms.M.Mohana Priya

ETL (Extract, Transform, Load) and **OLAP (Online Analytical Processing)** are crucial components of data warehousing and business intelligence, each serving distinct purposes but often working together to facilitate data analysis and reporting.

ETL (Extract, Transform, Load)

ETL is a process used to move data from source systems into a data warehouse or other data repository. It involves three main stages:

1. **Extract:**
 - **Definition:** The process of retrieving data from various source systems.
 - **Sources:** Can include databases, CRM systems, ERP systems, flat files, APIs, and other data sources.
2. **Transform:**
 - **Definition:** The process of cleaning, enriching, and converting data into a format suitable for analysis and storage.
3. **Load:**
 - **Definition:** The process of inserting transformed data into the target data warehouse or data repository.

OLAP refers to technologies that allow users to interactively analyze multidimensional data from multiple perspectives. OLAP enables complex queries, aggregations, and data analysis.

1. **OLAP Types:**
 - **ROLAP (Relational OLAP):**
 - **Definition:** Uses relational databases to store and manage data. OLAP operations are performed using SQL queries.
 - **Characteristics:** Offers flexibility and scalability by leveraging existing relational database infrastructure.
 - **Tools:** Oracle OLAP, IBM Cognos, Microsoft SQL Server Analysis Services (SSAS) with ROLAP.
 - **MOLAP (Multidimensional OLAP):**
 - **Definition:** Uses multidimensional data structures (OLAP cubes) to store and manage data. Data is pre-aggregated and stored in cubes.
2. • **Characteristics:** Provides fast query performance and supports complex calculations and aggregations.
3. • **Tools:** Microsoft SSAS with MOLAP, IBM Cognos TM1

CHAPTER 6

Data Warehousing Physical Design

Ms.M.Jeeva

Physical design in data warehousing focuses on how data is stored and managed on physical storage systems. This stage translates the logical design into a concrete implementation, addressing performance, storage, and retrieval considerations. The goal is to optimize the data warehouse for efficient query performance and data management.

Data Storage:

- **Definition:** The physical storage systems where data is persisted.
- **Options:**
 - **Disk Storage:** Hard drives or SSDs for storing data.
 - **Cloud Storage:** Cloud-based storage solutions (e.g., Amazon S3, Google Cloud Storage) for scalability and flexibility.

Table Design:

- **Tables:** Physical representation of fact and dimension tables from the logical design.
- **Considerations:**
 - **Table Structure:** Design tables with appropriate columns, data types, and constraints.

Indexing:

- **Definition:** Techniques to speed up data retrieval operations.
- **Types:**
 - **Primary Index:** Index on the primary key to enforce uniqueness and improve query performance.
 - **Secondary Index:** Additional indexes on other columns to support query operations.

Physical Design Process

1. **Translate Logical Design:**
 - **Objective:** Convert the logical design into physical tables, indexes, and storage structures.
 - **Activities:** Define table schemas, set up indexes, and plan data partitioning.
2. **Plan Data Storage:**
 - **Objective:** Determine where and how data will be physically stored.
 - **Activities:** Choose storage solutions, set up data partitions, and implement data compression.
 -

CHAPTER 7

Transportation in Data Warehouse

Ms.S.Gayathiri

Transportation in the context of data warehousing refers to the methods and processes used to move data between different environments or systems. This includes transferring data between source systems, staging areas, and the data warehouse itself, as well as moving data for backup, recovery, and migration purposes.

Key Aspects of Data Transportation

1. **Data Extraction:**
 - **Definition:** The process of retrieving data from source systems for loading into the data warehouse.
2. **Data Staging:**
 - **Definition:** Temporary storage of data extracted from source systems before it is transformed and loaded into the data warehouse.
3. **Data Loading:**
 - **Definition:** The process of inserting transformed data into the data warehouse.
4. **Data Migration:**
 - **Definition:** Moving data from one system or platform to another, often during system upgrades or transitions.
5. **Data Backup and Recovery:**
 - **Definition:** The process of creating and managing copies of data to ensure protection and recoverability in case of failures.

Ensure Data Integrity:

- **Objective:** Maintain the accuracy and consistency of data during transportation.
- **Methods:** Use checksums, validation rules, and data reconciliation techniques.

Optimize Performance:

- **Objective:** Improve the efficiency of data transportation processes.
- **Methods:** Use parallel processing, optimize data transfer protocols, and minimize data volume.

Secure Data Transfers:

- **Objective:** Protect data during transportation from unauthorized access and breaches.
- **Methods:** Implement encryption, use secure transfer protocols, and enforce access controls.

CHAPTER 8

Meta Data, Data Mart and Partition Strategy

Mr.K.Balamurali

Metadata, data marts, and partition strategies are essential components of data warehousing that play distinct but interrelated roles in managing and optimizing data for analysis and reporting.

Metadata refers to data about data. It provides information about the structure, definition, and context of data within the data warehouse. Metadata helps users understand and manage the data, improving data governance and usability.

Types of Metadata

1. Technical Metadata:

- **Definition:** Information about the technical aspects of data.
- **Examples:** Table structures, column definitions, data types, indexes, relationships, ETL processes.
- **Purpose:** Facilitates understanding of data architecture and aids in database maintenance and optimization.

2. Business Metadata:

- **Definition:** Information about the business context and meaning of data.
- **Examples:** Business definitions of data elements, business rules, data lineage, data usage.
- **Purpose:** Helps users interpret data correctly and ensures alignment with business Metadata Management.

Data Mart

Data Marts are specialized subsets of a data warehouse designed to focus on specific business areas or departments. They provide a more targeted view of data, tailored to the needs of particular user groups.

Types of Data Marts

Dependent Data Mart:

- **Definition:** Extracted from a central data warehouse.

Independent Data Mart:

- **Definition:** Operates independently of the central data warehouse.
- **Characteristics:** Directly collects and stores data from source systems, without relying on an EDW.

CHAPTER 9

Dimensional Model and Schema

Mr.K.Balamurali

The **dimensional model** and its associated **schemas** are fundamental concepts in data warehousing and business intelligence. They are designed to simplify complex data structures and enhance query performance, making it easier for users to analyze and report on data.

chema Design

Star Schema Design

1. **Fact Table:**
 - **Identify Measures:** Determine the key performance indicators (KPIs) and numeric data to be included.
 - **Design Granularity:** Decide the level of detail (e.g., daily transactions, monthly summaries).
2. **Dimension Tables:**
 - **Identify Dimensions:** Determine the descriptive attributes relevant to the measures (e.g., time, product, customer).
 - **Design Attributes:** Include relevant fields and hierarchies for each dimension (e.g., product category, region).

Snowflake Schema Design

1. **Normalize Dimensions:**
 - **Break Down Dimensions:** Split large dimension tables into smaller related tables to reduce redundancy (e.g., splitting "Product" into "Product" and "Product Category").
2. **Fact Table:**
 - **Similar to Star Schema:** The fact table design remains similar, but may include additional foreign keys to normalized dimension tables.

Galaxy Schema Design

1. **Identify Fact Tables:**
 - **Define Multiple Fact Tables:** Determine the different business processes to be analyzed and create separate fact tables for each (e.g., sales, inventory).
2. **Shared Dimension Tables:**
 - **Design Dimensions:** Create dimension tables that are shared among fact tables to maintain consistency and support cross-functional analysis.

Best Practices for Schema Design

1. **Understand Business Requirements:**
 - **Objective:** Ensure the schema meets the analytical needs and reporting requirements of the business.

CHAPTER 10

System and Process Management

Ms.M.Mohana Priya

System management encompasses the activities required to maintain and optimize the hardware, software, and network components of an IT environment. It aims to ensure system availability, performance, and security.

Key Components

1. System Administration:

- **Definition:** The management of system resources and configurations to ensure smooth operation.
- **Tasks:**
 - **Installation:** Setting up operating systems, applications, and updates.
 - **Configuration:** Customizing system settings and parameters to meet organizational needs.
 - **Monitoring:** Tracking system performance, resource usage, and availability.

2. Hardware Management:

- **Definition:** Managing physical hardware components such as servers, storage devices, and network equipment.

Process Management

Process management involves overseeing and optimizing business processes to improve efficiency, effectiveness, and agility. It focuses on managing workflows, procedures, and the resources involved in delivering products or services.

Key Components

1. Process Design:

- **Definition:** The creation and documentation of processes to achieve specific business goals.

Process Implementation:

- **Definition:** Putting the designed processes into action.
- **Tasks:**
 - **Training:** Educating employees on new processes and procedures.

Process Monitoring:

- **Definition:** Tracking the performance and compliance of processes.

VIRTUALIZATION

Edited by

S.GAYATHRI



978-93-6255-526-7

VIRTUALIZATION

Copyright © 2023 by S.GAYATHRI

All rights reserved. No part of this book may be reproduced or transmitted in any form or by any means without written permission from the author.

ISBN: 978-93-6255-526-7

Publisher: Ponnaiyah Ramajayam Institute of Science and Technology (PRIST)

TABLE OF CONTENTS

| | | |
|--|---|------------|
| Introduction | - | 03 |
| CHAPTER 1 – Server and Desktop Virtualization | - | 14 |
| Ms.M.Jeeva | | |
| CHAPTER 2 – Network Virtualization | - | 42 |
| Ms.S.Gayathiri | | |
| CHAPTER 3 – Virtualizing the Campus WAN Design | - | 65 |
| Dr. R.Latha | | |
| CHAPTER 4 – Access Virtualization | - | 84 |
| Ms.M.Jeeva | | |
| CHAPTER 5 – Application Virtualization | - | 135 |
| Ms.M.Mohana Priya | | |
| CHAPTER 6 – Process Virtualization | - | 157 |
| Ms.M.Jeeva | | |
| CHAPTER 7 – Storage Virtualization | - | 189 |
| Ms.S.Gayathiri | | |
| CHAPTER 8 – Security for Virtual Environments | - | 214 |
| Ms.S.Gayathiri | | |
| CHAPTER 9 – Management for Virtual Environments | - | 243 |
| Ms.R.Bhanumathi | | |
| CHAPTER 10 – Virtualization tools | - | 252 |
| Ms.M.Mohana Priya | | |
| REFERENCES | - | 275 |

CHAPTER 1

Server and Desktop Virtualization

Ms.M.Jeeva

Server Virtualization

Server virtualization involves creating multiple virtual servers on a single physical server. Each virtual server (or virtual machine, VM) operates independently with its own operating system (OS) and applications. This allows for better resource utilization, isolation, and scalability.

1. Key Concepts:

- **Hypervisor:** Software that enables the creation and management of virtual machines. It sits between the hardware and the operating systems.
 - **Type 1 Hypervisor (Bare-Metal):** Runs directly on the physical hardware. Examples include VMware ESXi, Microsoft Hyper-V, and Xen.
 - **Type 2 Hypervisor (Hosted):** Runs on top of a host operating system. Examples include VMware Workstation and Oracle VirtualBox.

Desktop Virtualization

Desktop virtualization involves running desktop environments on a centralized server rather than on individual user devices. Users access their virtual desktops through a network connection, typically using thin clients or other endpoint devices.

1. Key Concepts:

- **Virtual Desktop Infrastructure (VDI):** A model where desktop operating systems and applications are hosted on virtual machines in a data center. Users access their desktops remotely over a network.

Comparison of Server and Desktop Virtualization

1. Purpose:

- **Server Virtualization:** Focuses on optimizing server resources and providing isolated environments for applications and services.
- **Desktop Virtualization:** Focuses on providing centralized and remote access to desktop environments for end users.

2. Resource Management:

- **Server Virtualization:** Manages server resources such as CPU, memory, and storage for running multiple virtual servers.
- **Desktop Virtualization:** Manages desktop resources and user environments, including user profiles, applications, and data.

3. User Experience:

- **Server Virtualization:** Generally invisible to end users; impacts the backend infrastructure and application delivery.

CHAPTER 2

Network Virtualization

Ms.S.Gayathiri

Network virtualization is a technology that abstracts and separates the physical network infrastructure from the network services and functions, allowing for more flexible and efficient network management. It involves creating virtual networks on top of physical network hardware, enabling multiple virtual networks to share the same physical infrastructure while operating independently.

Virtual Network:

- **Definition:** A logical network that is created by abstracting the underlying physical network infrastructure. Virtual networks are isolated from each other, allowing multiple virtual networks to coexist on the same physical network.
- **Components:** Includes virtual switches, virtual routers, and virtual firewalls.

Virtual Switch:

- **Definition:** A software-based switch that operates within a virtualized environment, managing network traffic between virtual machines (VMs) or other virtual network components.
- **Examples:** VMware vSwitch, Open vSwitch.

Virtual Router:

- **Definition:** A software-based router that provides routing functionality within a virtual network. It can handle traffic routing between virtual networks or between virtual and physical networks.
- **Examples:** VyOS, Cisco CSR 1000V.

Network Functions Virtualization (NFV):

- **Definition:** Virtualizes network functions traditionally performed by dedicated hardware appliances (e.g., firewalls, load balancers) and runs them as software on standard servers.
- **Benefits:** Reduces hardware dependency, enhances flexibility, and simplifies management.

Software-Defined Networking (SDN):

- **Definition:** An approach to network management that uses software-based controllers to manage and control network traffic, decoupling the control plane from the data plane.

- **Benefits:** Centralized management, dynamic network provisioning, and improved network agility.

CHAPTER 3

Virtualizing the Campus WAN Design

Dr. R.Latha

Virtualizing the Campus WAN (Wide Area Network) involves applying virtualization technologies to the WAN infrastructure of a campus network to improve efficiency, flexibility, and manageability. This process can include virtualizing network services, optimizing WAN performance, and integrating with broader network virtualization strategies.

1. WAN Optimization:

- **Definition:** Techniques and technologies used to improve the performance and efficiency of data transfer across the WAN.
- **Techniques:**
 - **Compression:** Reduces the size of data transmitted over the WAN.
 - **Deduplication:** Eliminates duplicate data to minimize bandwidth usage.
 - **Caching:** Stores frequently accessed data locally to reduce latency and improve access speed.

2. Software-Defined WAN (SD-WAN):

- **Definition:** An approach to WAN management that uses software to control and optimize WAN traffic, allowing for more flexible and efficient network operations.

3. Network Functions Virtualization (NFV):

- **Definition:** Virtualizes network functions traditionally performed by hardware appliances, such as firewalls, load balancers, and WAN optimizers, running them as software on standard servers.
- **Benefits:** Reduces hardware dependency, enhances flexibility, and simplifies deployment and management.

4. Virtual Network Functions (VNFs):

- **Definition:** Virtualized versions of traditional network functions, which can be deployed and managed as software instances within a virtualized environment.
- **Examples:** Virtual firewalls, virtual load balancers, and virtual routers.

5. Overlay Networks:

- **Definition:** Virtual networks built on top of physical network infrastructure using encapsulation and tunneling protocols.
- **Examples:** Virtual Extensible LAN (VXLAN), Generic Routing Encapsulation (GRE)

Benefits of Virtualizing the Campus WAN

1. Improved Performance and Efficiency:

- **Optimization:** Enhance WAN performance through techniques like WAN optimization and SD-WAN.
- **Bandwidth Utilization:** Better manage and utilize available bandwidth with optimized routing and application-aware policies.

CHAPTER 4

Access Virtualization

Ms.M.Jeeva

Access virtualization refers to the process of abstracting and managing user access to IT resources—such as applications, desktops, and data—through a virtualized environment. It aims to provide users with seamless and secure access to resources from various devices and locations while centralizing management and control.

1. **Virtual Desktop Infrastructure (VDI):**
 - **Definition:** A technology that allows users to access a virtual desktop environment hosted on a central server. Each user interacts with their virtual desktop as if it were a local machine, but it is actually running on a remote server.
 - **Benefits:** Centralized management, improved security, and flexible access.
2. **Remote Desktop Services (RDS):**
 - **Definition:** Provides access to applications and desktops hosted on a central server. Unlike VDI, RDS can provide access to a shared desktop environment or specific applications rather than a full desktop.
 - **Examples:** Microsoft Remote Desktop Services (RDS), Citrix XenApp.
3. **Application Virtualization:**
 - **Definition:** Enables applications to run on client devices as if they were installed locally, while the actual application is hosted on a central server or virtual environment.
 - **Examples:** Amazon WorkSpaces, Microsoft Azure Virtual Desktop.

Benefits of Access Virtualization

1. **Centralized Management:**
 - **Simplified Administration:** Manage user access and virtual environments from a central location, reducing administrative overhead and complexity.
 - **Consistent Experience:** Ensure a consistent user experience by providing standardized virtual desktops and applications.
2. **Enhanced Security:**
 - **Data Protection:** Keep sensitive data centralized and secure on servers rather than on endpoint devices, reducing the risk of data loss or theft.
 - **Access Controls:** Implement strong authentication, authorization, and monitoring to secure access to virtual resources.
3. **Flexibility and Accessibility:**
 - **Remote Access:** Enable users to access virtual desktops and applications from various devices and locations, supporting remote work and mobility.

- **Device Independence:** Allow users to connect from different devices, including thin clients, laptops, and tablets.
- 4. **Cost Efficiency:**
 - **Reduced Hardware Costs:** Minimize the need for high-performance hardware on client devices by leveraging centralized virtual resources.

CHAPTER 5

Application Virtualization

Ms.M.Mohana Priya

Application virtualization is a technology that allows applications to run in a virtual environment, abstracting them from the underlying operating system and hardware. This enables applications to be deployed, managed, and accessed independently of the physical infrastructure, providing flexibility, efficiency, and improved management.

□ **Application Virtualization:**

- **Definition:** A method that allows applications to run on client devices without being installed locally. The application runs in a virtual environment on a server or in a container, and the user interacts with it as if it were a local application.
- **Benefits:** Simplifies deployment, reduces compatibility issues, and enhances security.

□ **Application Containerization:**

- **Definition:** Encapsulates an application and its dependencies into a container, which can then be run consistently across different environments. Containers share the host OS kernel but isolate application processes and dependencies.

□ **Application Layer Virtualization:**

- **Definition:** Virtualizes the application layer independently of the operating system and hardware, allowing multiple applications to run on the same machine without conflict.

Benefits of Application Virtualization

1. **Simplified Deployment and Management:**

- **Centralized Management:** Deploy and update applications from a central location, reducing the need for manual installations on individual devices.
- **Consistency:** Ensure consistent application versions and configurations across all user devices.

2. **Enhanced Security:**

- **Isolation:** Run applications in isolated environments to minimize the risk of malware and security breaches affecting the entire system.
- **Controlled Access:** Manage and restrict application access based on user roles and policies.

3. **Reduced Compatibility Issues:**

- **Compatibility:** Address compatibility issues by running applications in virtual environments that are independent of the underlying operating system.
- **Legacy Applications:** Support legacy applications that may not be compatible with newer operating systems or hardware.

CHAPTER 6 **Process Virtualization**

Ms.M.Jeeva

Process virtualization is a technology that abstracts and isolates software processes from the underlying hardware and operating system, enabling processes to run independently and seamlessly across different environments. This approach allows for improved management, scalability, and portability of applications and services.

□ **Process Abstraction:**

- **Definition:** Separates the execution of a software process from the physical hardware and operating system, creating a virtual environment in which the process can operate.
- **Benefits:** Enhances portability, compatibility, and resource management.

□ **Containerization:**

- **Definition:** A method of process virtualization where applications and their dependencies are packaged into containers that can run consistently across different environments. Containers share the host OS kernel but are isolated from each other.
- **Examples:** Docker, Podman.

□ **Hypervisor:**

- **Definition:** A layer of software that enables multiple virtual machines (VMs) to run on a single physical host. Each VM runs its own operating system and processes, isolated

Challenges and Considerations

1. **Performance Overhead:**

- **Latency:** Virtualization may introduce performance overhead due to abstraction layers and resource contention.
- **Resource Management:** Ensure sufficient resources are allocated to virtualized processes to avoid performance degradation.

2. **Security:**

- **Isolation:** Ensure strong isolation between virtualized processes to prevent security issues from spreading.
- **Vulnerabilities:** Regularly update and patch virtualization platforms to address security vulnerabilities.

3. Complexity:

- **Management:** Managing virtualized processes, including configuration, monitoring, and troubleshooting, can be complex.
- **Integration:** Integrating virtualized processes with existing IT infrastructure may require careful planning.

CHAPTER 7

Storage Virtualization

Ms.S.Gayathiri

Storage virtualization is a technology that abstracts physical storage resources into a unified virtual pool, enabling more flexible and efficient management of storage resources. It separates storage management from the underlying hardware, allowing for improved scalability, resource utilization, and ease of management.

Storage Abstraction:

- **Definition:** The process of abstracting physical storage devices (e.g., hard drives, SSDs) into a virtualized storage environment that appears as a single, unified resource.
- **Benefits:** Simplifies management, improves resource utilization, and provides a more flexible storage infrastructure.

Storage Pools:

- **Definition:** A collection of physical storage resources that are aggregated and presented as a single logical unit. Storage pools allow for dynamic allocation and management of storage resources.

Storage Area Network (SAN):

- **Definition:** A high-speed network that provides access to consolidated storage resources, enabling multiple servers to access shared storage devices.

Plan and Design:

- **Architecture:** Design a storage virtualization architecture that aligns with organizational needs, including scalability, performance, and security.
- **Resource Requirements:** Assess the storage requirements of applications and workloads to optimize virtualization strategies.

Secure:

- **Data Protection:** Implement strong data protection measures, including encryption and access controls, to safeguard virtualized storage.

- **Monitoring:** Monitor storage environments for potential security threats and vulnerabilities.

Optimize and Monitor:

- **Performance:** Continuously monitor and optimize the performance of virtualized storage to ensure efficient operation and responsiveness.

CHAPTER 8

Security for Virtual Environments

Ms.S.Gayathiri

Security for virtual environments is crucial to protect the integrity, confidentiality, and availability of virtualized resources and data. As virtualization introduces new layers of abstraction and complexity, it is essential to implement robust security measures to safeguard virtual machines (VMs), containers, and virtual networks.

1. Virtual Machine Security:

- **Isolation:** Ensure strong isolation between VMs to prevent one VM from affecting others. Implement hypervisor security measures to enforce isolation.
- **Patch Management:** Regularly update and patch both the host and guest operating systems to address security vulnerabilities.
- **Access Controls:** Implement strong access controls and authentication mechanisms for managing VMs. Use role-based access control (RBAC) to restrict administrative access.

2. Container Security:

- **Image Security:** Use trusted and verified container images. Regularly scan container images for vulnerabilities and malware.
- **Runtime Security:** Monitor and secure container runtime environments to detect and respond to security threats. Use tools to enforce runtime security policies.
- **Isolation:** Ensure containers are isolated from each other and the host system to prevent unauthorized access and breaches.

3. Hypervisor Security:

- **Secure Configuration:** Configure hypervisors securely, following best practices and guidelines from vendors. Disable unnecessary services and features.
- **Patch Management:** Regularly apply updates and patches to hypervisors to address known vulnerabilities.
- **Monitoring:** Continuously monitor hypervisor activity for signs of potential security breaches or misconfigurations.

4. Network Security:

- **Virtual Networks:** Implement security measures for virtual networks, including firewalls, intrusion detection systems (IDS), and intrusion prevention systems (IPS).
- **Segmentation:** Use network segmentation to isolate virtual networks and control traffic flow between them.

- **Encryption:** Encrypt data in transit between virtual machines and across virtual networks to protect against interception and eavesdropping.
5. **Data Security:**
- **Encryption:** Encrypt data at rest and in transit to protect sensitive information from unauthorized access.
 - **Backup and Recovery:** Implement robust backup and recovery solutions to ensure data can be restored in case of a breach or data loss.
 - **Access Controls:** Apply strong access controls to virtualized storage resources and data.

CHAPTER 9

Management for Virtual Environments

Ms.R.Bhanumathi

Management for virtual environments involves overseeing and controlling virtualized resources, including virtual machines (VMs), containers, virtual networks, and storage. Effective management ensures that virtual environments are secure, efficient, and aligned with organizational goals. This includes tasks such as provisioning, monitoring, optimizing, and maintaining virtual resources.

Provisioning and Deployment:

- **Automated Provisioning:** Use automation tools to deploy and configure virtual resources quickly and consistently. Examples include Infrastructure as Code (IaC) tools like Terraform and configuration management tools like Ansible.
- **Templates and Blueprints:** Create and use templates or blueprints for consistent and repeatable deployments of VMs, containers, and applications.

Monitoring and Performance Management:

- **Monitoring Tools:** Implement monitoring solutions to track the performance and health of virtual resources. Tools may include Nagios, Prometheus, and cloud-native monitoring services.
- **Performance Metrics:** Monitor key performance metrics such as CPU usage, memory utilization, disk I/O, and network bandwidth to ensure optimal performance.
- **Alerting:** Set up alerts for performance issues, security events, and other critical conditions to enable timely response and resolution.

Resource Allocation and Optimization:

- **Capacity Planning:** Regularly assess resource utilization and plan for future growth to ensure sufficient capacity for virtual resources.
- **Resource Optimization:** Optimize resource allocation to balance workloads, reduce waste, and improve efficiency. Techniques include rightsizing VMs and using auto-scaling features.

- **Storage Management:** Manage storage resources, including provisioning, resizing, and optimizing storage volumes and data.

Automate Where Possible:

- Leverage automation tools and scripts to streamline provisioning, configuration, and management tasks. Automation reduces manual effort and minimizes errors.
- Continuously monitor virtual environments to detect and address issues proactively. Perform regular maintenance to keep systems up-to-date and secure.

CHAPTER 10

Virtualization tools

Ms.M.Mohana Priya

Virtualization tools are software applications and platforms designed to create, manage, and optimize virtual environments. These tools enable the abstraction and isolation of physical resources into virtual resources, such as virtual machines (VMs), containers, and virtual networks. They play a critical role in simplifying management, enhancing efficiency, and improving resource utilization in virtualized environments.

Hypervisors:

- **Definition:** Software that creates and manages virtual machines by abstracting physical hardware resources. Hypervisors can be classified into two types:

Containerization Platforms:

- **Definition:** Tools that manage and orchestrate containers, which are lightweight, portable, and isolated environments for running applications.
 - **Docker:** A popular containerization platform that allows developers to package applications and their dependencies into containers.

Storage Virtualization Tools:

- **Definition:** Tools that abstract and manage physical storage resources to create a unified virtual storage environment.
 - **VMware vSAN:** VMware's solution for hyper-converged infrastructure, providing storage virtualization and management.

Network Virtualization Tools:

- **Definition:** Tools that create and manage virtual networks to enhance network flexibility and management.
 - **VMware NSX:** A network virtualization platform that provides network and security virtualization for data centers.

- **Cisco ACI:** Cisco's application-centric infrastructure solution that provides network virtualization and automation.

Management and Orchestration Tools:

- **Definition:** Tools that automate and streamline the management and orchestration of virtual resources.
 - **VMware vCenter:** A management tool for overseeing VMware environments, including VM provisioning, monitoring, and configuration.



BIODIVERSITY AND ITS CONSERVATION

EDITED BY

DR. C. ANITHA



978-93-6255-879-4

BIODIVERSITY AND ITS CONSERVATION

Copyright © 2023 by Dr. C. Anitha

All rights reserved. No part of this book may be reproduced or transmitted in any form or by any means without written permission from the author.

ISBN: 978-93-6255-879-4

Publisher: Ponnaiyah Ramajayam Institute of Science and Technology (PRIST)

TABLE OF CONTENTS

| | |
|--|------------|
| CHAPTER 1 - Definition: genetic, species and ecosystem diversity..... | 01 |
| Dr. S. RAMADEVI | |
| CHAPTER 2 - Bio-geographical classification of India..... | 18 |
| Dr. T. VEERAMANI | |
| CHAPTER 3 - Value of biodiversity: consumptive use, productive use, social, ethical, aesthetic and option values..... | 29 |
| Dr. C. ANITHA | |
| CHAPTER 4 - India as a mega-diversity nation..... | 36 |
| Dr. J. ILAMATHI | |
| CHAPTER 5 - Western Ghat as a biodiversity region..... | 48 |
| Dr. R. KAMARAJ | |
| CHAPTER 6 - Hotspot of biodiversity..... | 59 |
| Dr. J. JEYASREE | |
| CHAPTER 7 - Threats to biodiversity habitat loss, poaching of wildlife, man-wildlife conflicts | 62 |
| Dr. R. ARUNKUMAR | |
| CHAPTER 8 - Ecosystem Services: Benefits of Biodiversity..... | 73 |
| Dr. C. ANITHA | |
| CHAPTER 9 - Climate Change and Biodiversity..... | 89 |
| Dr. T. VEERAMANI | |
| CHAPTER 10 - Role of Indigenous Communities in Biodiversity Conservation..... | 98 |
| Dr. C. ANITHA | |
| REFERENCES | 110 |

CHAPTER 1

Definition: genetic, species and ecosystem diversity

Dr. S. RAMADEVI

*Assistant Professor, Department of Biotechnology
Ponnaiyah Ramajayam Institute of Science and Technology*

Ecosystem Biodiversity

Biodiversity is the complex web of life that sustains ecosystems, human societies, and the planet's health. It is often broken down into three primary components: genetic diversity, species diversity, and ecosystem diversity. Each plays a critical role in maintaining the stability, resilience, and functionality of ecosystems.

Genetic diversity refers to the variation in genetic material within a species, enabling populations to adapt to changes in their environment, resist diseases, and thrive under different conditions. High genetic diversity strengthens a species' ability to survive environmental changes, while low diversity increases vulnerability to threats like climate change, pests, and habitat loss.

Species diversity is the variety of species within a particular region or ecosystem. It includes species richness (the number of different species) and species evenness (the relative abundance of each species). High species diversity enhances ecosystem productivity, stability, and resilience, allowing ecosystems to provide vital services such as pollination, water purification, and nutrient cycling.

Ecosystem diversity refers to the variety of ecosystems within a given area or across the planet. Each ecosystem, whether a forest, grassland, wetland, or marine environment, supports different biological communities and ecological processes. Diverse ecosystems contribute to a more stable and resilient environment by supporting a range of habitats and species.

The interconnectedness of genetic, species, and ecosystem diversity forms the foundation of life on Earth. Protecting biodiversity ensures the health and stability of ecosystems, which are essential for human well-being, climate regulation, food

CHAPTER 2

Bio-geographical classification of India

Dr. T. VEERAMANI

*Assistant Professor, Department of Biotechnology
Ponnaiyah Ramajayam Institute of Science and Technology*

India's vast and varied landscapes give rise to immense biodiversity, which has been classified into distinct biogeographical zones based on climate, topography, and vegetation. The Biogeographical Classification of India, developed by the Wildlife Institute of India, identifies 10 biogeographical zones, each hosting unique ecosystems and species. These zones are:

1. **Trans-Himalaya:**

Covering the high-altitude cold deserts of Ladakh and the Tibetan Plateau, this zone has a harsh climate and low biodiversity, with species adapted to extreme cold, such as the snow leopard and Tibetan antelope.

2. **Himalaya:**

Stretching from Jammu and Kashmir to Arunachal Pradesh, this region includes a wide range of ecosystems, from temperate forests to alpine meadows, with rich biodiversity, including rare species like the red panda and Himalayan monal.

3. **Indian Desert:**

The Thar Desert in western India, characterized by arid conditions, sparse vegetation, and drought-resistant species such as camels and the Indian bustard.

4. **Semi-Arid:**

Found between the desert and peninsular India, this region has a dry climate with thorn forests and grasslands. Species include blackbuck, chinkara, and several bird species.

5. **Western Ghats:**

A biodiversity hotspot, this mountain range runs along the western coast, known for its tropical rainforests and high endemic species diversity, including the Nilgiri tahr and lion-tailed macaque.

6. **Deccan Peninsula:**

The largest biogeographical zone, covering much of central and southern India. It includes tropical dry forests and scrublands, with key species like tigers, elephants, and gaur.

CHAPTER 3

Value of biodiversity: consumptive use, productive use, social, ethical, aesthetic and option values

Dr. C. ANITHA

*Assistant Professor, Department of Biotechnology
Ponnaiyah Ramajayam Institute of Science and Technology*

Biodiversity provides a wide range of values that are critical to ecosystems, economies, and human well-being. These values can be broadly classified into consumptive use, productive use, social, ethical, aesthetic, and option values:

Consumptive Use Value:

This refers to the direct consumption of biodiversity resources, such as food, medicine, and fuel, without entering the market. Local communities often rely on biodiversity for daily sustenance, using plants for food and herbs for traditional medicine.

Productive Use Value:

Biodiversity is crucial to economic production, providing raw materials for industries. Products like timber, agricultural crops, pharmaceuticals, and fisheries are derived from biodiversity and traded globally. These resources support livelihoods and drive economic growth.

Social Value:

Biodiversity has social significance, forming the basis for traditional knowledge systems, cultural practices, and livelihoods. Many indigenous and local communities have deep connections to biodiversity, using it for food, shelter, and spiritual practices.

Ethical Value:

Biodiversity holds intrinsic value, where species and ecosystems are respected for their right to exist, regardless of their utility to humans. Ethical values drive conservation efforts, recognizing that all forms of life have an inherent right to thrive.

Aesthetic Value:

Biodiversity contributes to the beauty of nature, offering inspiration for art, literature, and tourism. Natural landscapes, wildlife, and plants enrich human experiences and are valued for their beauty and recreational potential.

CHAPTER 4

India as a mega-diversity nation

Dr. J. ILAMATHI

*Assistant Professor, Department of Biotechnology
Ponnaiyah Ramajayam Institute of Science and Technology*

India is recognized as one of the world's 17 megadiverse nations, housing a significant portion of the planet's biodiversity. With just 2.4% of the Earth's land area, India harbors over 8% of global species diversity, making it a biodiversity hotspot. This is due to its diverse landscapes, climates, and ecosystems, ranging from snow-capped Himalayan mountains to tropical rainforests, arid deserts, and extensive coastlines.

India's biodiversity includes over 45,000 plant species and 91,000 animal species, many of which are endemic. The country is home to a rich variety of mammals, birds, reptiles, amphibians, insects, and marine life, as well as valuable genetic diversity within cultivated crops and domesticated animals. Regions such as the Western Ghats and North-Eastern India are recognized as biodiversity hotspots due to their high levels of endemic species.

India's status as a megadiversity nation is not only due to its species richness but also its diverse ecosystems. It includes tropical and temperate forests, grasslands, wetlands, coral reefs, and mangroves. These ecosystems support complex ecological processes and provide crucial ecosystem services, including water regulation, climate moderation, and soil fertility.

India's rich cultural diversity also contributes to the conservation of its biodiversity. Indigenous and traditional communities have long been custodians of local ecosystems, relying on their sustainable use for food, medicine, and cultural practices.

As a megadiversity nation, India has a critical role to play in global conservation efforts, balancing its growing development needs with the responsibility to protect and sustainably manage its vast biodiversity for future generations.

CHAPTER 5

Western Ghat as a biodiversity region

Dr. R. KAMARAJ

*Assistant Professor, Department of Biotechnology
Ponnaiyah Ramajayam Institute of Science and Technology*

The Western Ghats, a mountain range stretching along the western coast of India, is one of the world's eight "hottest" biodiversity hotspots and is recognized for its extraordinary ecological significance. Spanning over six Indian states—Gujarat, Maharashtra, Goa, Karnataka, Tamil Nadu, and Kerala—this region is home to a wide array of ecosystems, ranging from tropical rainforests to grasslands.

The Western Ghats harbor more than 7,400 species of flowering plants, 139 mammal species, 508 bird species, 179 amphibian species, and 6,000 insect species, with a high degree of endemism. Over 30% of its plant species and a significant portion of its animal species are endemic, meaning they are found nowhere else on Earth. Iconic wildlife in this region includes the Nilgiri tahr, lion-tailed macaque, Malabar giant squirrel, and numerous amphibians like the purple frog.

The region plays a critical role in water regulation, as it houses the origins of several major rivers, including the Godavari, Krishna, and Cauvery, which support millions of people. The forests of the Western Ghats also provide ecosystem services like carbon sequestration, soil stabilization, and climate moderation.

However, the Western Ghats face significant threats from deforestation, habitat fragmentation, and infrastructure development, which put pressure on its biodiversity. Conservation initiatives, including the designation of protected areas such as national parks and wildlife sanctuaries, along with UNESCO recognition as a World Heritage Site, highlight the importance of preserving this vital biodiversity region for future generations.

CHAPTER 6

Hotspot of biodiversity

Dr. J. JEYASREE

*Assistant Professor, Department of Biotechnology
Ponnaiyah Ramajayam Institute of Science and Technology*

A biodiversity hotspot is a region that is both rich in biodiversity and significantly threatened by human activities. To qualify as a hotspot, a region must meet two criteria: it must contain at least 1,500 species of vascular plants as endemics, meaning they are found nowhere else, and it must have lost at least 70% of its original habitat. These areas are critical for global conservation efforts because they house a vast array of species, many of which are unique and vulnerable to extinction.

There are currently 36 recognized biodiversity hotspots around the world, covering only about 2.3% of the Earth's land surface. Despite this small area, they support more than half of the world's plant species and nearly 43% of bird, mammal, reptile, and amphibian species. Examples include the Western Ghats in India, Madagascar, and the Amazon Rainforest.

Biodiversity hotspots face extreme pressure from deforestation, urbanization, agriculture, and climate change. The high levels of endemic species mean that when habitats are destroyed, species unique to these regions are at a heightened risk of extinction. Protecting these areas is therefore crucial for preserving global biodiversity.

Conservation efforts in hotspots are essential not just for the species they contain, but also for the ecosystem services they provide, such as climate regulation, water purification, and carbon sequestration. By focusing on biodiversity hotspots, conservationists aim to maximize the impact of limited resources, protecting the most species-rich and ecologically valuable areas on Earth.

CHAPTER 7

Threats to biodiversity habitat loss, poaching of wildlife, man-wildlife conflicts

Dr. R. ARUNKUMAR

*Assistant Professor, Department of Biotechnology
Ponnaiyah Ramajayam Institute of Science and Technology*

Biodiversity faces numerous threats worldwide, and some of the most significant include habitat loss, poaching of wildlife, and man-wildlife conflicts:

Habitat Loss:

Habitat loss is the most critical threat to biodiversity. It occurs when natural environments like forests, wetlands, grasslands, and coral reefs are destroyed or altered, often due to agriculture, urbanization, infrastructure development, logging, and mining. This destruction leads to the fragmentation of ecosystems, making it difficult for species to survive and reproduce. Many species lose their homes or are forced into smaller, isolated patches, which reduces genetic diversity and increases the risk of extinction. For example, deforestation in the Amazon and Western Ghats has severely impacted countless species and ecosystems.

Poaching of Wildlife:

Poaching, or the illegal hunting and trade of wildlife, is a major threat to species, particularly those valued for their body parts (e.g., tusks, horns, fur, or bones). Poaching fuels the illegal wildlife trade and has driven species like rhinos, tigers, and elephants to the brink of extinction. The demand for exotic pets, traditional medicines, and luxury goods contributes to this illegal activity, further endangering already vulnerable species. Poaching not only disrupts ecosystems but also diminishes wildlife populations at unsustainable rates.

Man-Wildlife Conflicts:

As human populations expand, the overlap between human settlements and wildlife habitats increases, leading to conflicts. These conflicts often arise when animals damage crops, livestock, or property, or pose threats to human safety. In retaliation, people may kill or harm the animals involved. Man-wildlife conflicts are common in areas like the Western Ghats, where animals like elephants and leopards come into

CHAPTER 8

Ecosystem Services: Benefits of Biodiversity

Dr. C. ANITHA

*Assistant Professor, Department of Biotechnology
Ponnaiyah Ramajayam Institute of Science and Technology*

Biodiversity is essential for the provision of ecosystem services, which are the benefits humans derive from nature. These services are broadly classified into four categories: provisioning, regulating, cultural, and supporting services.

Provisioning services include the tangible products that ecosystems provide, such as food, water, timber, and medicinal resources. Agricultural crops, fish, and livestock all depend on the biodiversity of the natural world. Many medicinal plants, essential for healthcare, are derived from biodiverse ecosystems.

Regulating services are the natural processes that ecosystems regulate, such as climate control, disease regulation, water purification, and pollination. Forests and wetlands help regulate water cycles and mitigate the effects of floods, while diverse ecosystems sequester carbon, helping reduce the impact of climate change.

Cultural services refer to the non-material benefits people obtain from nature, including recreation, spiritual fulfillment, and aesthetic appreciation. Many cultures hold strong spiritual connections with nature, while landscapes and wildlife inspire art, tourism, and cultural identity.

Supporting services underpin all other ecosystem services, involving fundamental processes like nutrient cycling, soil formation, and photosynthesis. Without these processes, ecosystems would not function, and life on Earth would not be sustained.

Protecting biodiversity ensures the continued flow of these ecosystem services, which are vital for human survival and well-being.

CHAPTER 9

Climate Change and Biodiversity

Dr. T. VEERAMANI

*Assistant Professor, Department of Biotechnology
Ponnaiyah Ramajayam Institute of Science and Technology*

Climate change poses a severe threat to biodiversity, altering habitats, ecosystems, and the survival of many species. As global temperatures rise due to increased greenhouse gas emissions, biodiversity is impacted in multiple ways.

Habitat shifts occur as species migrate to cooler areas, either to higher altitudes or latitudes. For instance, alpine species in mountainous regions are forced to move upward, reducing their available habitat. In some cases, species may not adapt quickly enough, leading to population decline or extinction.

Coral reefs, among the most biodiverse ecosystems, are particularly vulnerable to climate change. Rising sea temperatures cause coral bleaching, which weakens the corals and affects the myriad species that depend on them for shelter and food.

Climate change also affects phenology, the timing of biological events such as flowering, migration, and breeding. Changes in these patterns can disrupt food chains and species interactions, putting ecosystems under stress.

Extreme weather events, such as droughts, storms, and floods, are becoming more frequent and severe due to climate change. These events can damage habitats, wipe out species populations, and alter ecosystems.

Mitigating climate change through sustainable practices and reducing carbon emissions is essential to preserving biodiversity. Adaptive conservation strategies, such as creating climate corridors and protecting climate-resilient ecosystems, can help safeguard biodiversity from the impacts of a warming planet.

CHAPTER 10

Role of Indigenous Communities in Biodiversity Conservation

Dr. C. ANITHA

*Assistant Professor, Department of Biotechnology
Ponnaiyah Ramajayam Institute of Science and Technology*

Indigenous communities play a vital role in the conservation of biodiversity due to their deep-rooted knowledge and sustainable practices. For centuries, these communities have lived in harmony with nature, relying on biodiversity for food, medicine, shelter, and cultural traditions. Their intimate understanding of local ecosystems makes them invaluable stewards of biodiversity.

Indigenous knowledge systems, often passed down through generations, include sustainable resource management techniques such as rotational farming, controlled burning, and the protection of sacred groves. These practices help maintain the health of ecosystems and prevent overexploitation. For example, many indigenous groups in the Amazon use agroforestry, a farming system that mimics natural forests, to grow crops while conserving biodiversity.

In many cases, indigenous territories overlap with biodiversity-rich areas, including several biodiversity hotspots and protected areas. Studies show that biodiversity is often better preserved in regions managed by indigenous peoples than in state-protected areas, as their practices are designed to sustain ecosystems for future generations.

International agreements like the Convention on Biological Diversity (CBD) acknowledge the importance of integrating indigenous knowledge into global conservation efforts. Ensuring indigenous communities' rights to land and resources, and involving them in decision-making processes, is essential for effective biodiversity conservation. Supporting their role as environmental guardians helps protect biodiversity and promotes sustainable development worldwide.

ECOSYSTEMS

Edited by

DR. T. VEERAMANI



978-93-6255-577-9

ECOSYSTEM

Copyright©2023 *By Dr. T. Veeramani*

All rights reserved. No part of this book may be reproduced or transmitted in any form or by any means without written permission from the author.

ISSN: 978-93-6255-577-9

Publisher: Ponnaiyah Ramajayam Institute of Science and Technology (PRIST)

TABLE OF THE CONTENTS

| | |
|--|-----|
| CHAPTER :1 Introduction to Ecosystems <i>Dr. T. Veeramani</i> | 1 |
| CHAPTER :2 The Effects of Technology and Environmental Pollution on Biodiversity Conservation <i>Dr. T. Veeramani</i> | 12 |
| CHAPTER :3 An Analysis of the Increase in Irrigated Area Under Groundwater <i>Dr. R. Arunkumar</i> | 24 |
| CHAPTER :4 Availability in India's Various Irrigation Sources: A Statistical Method <i>Dr. J. Ilamathi</i> | 31 |
| CHAPTER :5 Groundwater's Significance in Harmonizing with the Environment <i>Dr. T. Veeramani</i> | 45 |
| CHAPTER :6 Bacteria as Pollution Indicators in the Environment <i>Dr. Arjunpandian</i> | 59 |
| CHAPTER :7 Global Marine Ecosystem <i>Dr. R. Arunkumar</i> | 70 |
| CHAPTER :8 Using Geo-Information Systems in Assessing Water Quality <i>Dr. T. Veeramani</i> | 85 |
| CHAPTER :9 Theorem for Ideal Biodiversity and Ecosystem Performance <i>Dr. C. Anitha</i> | 103 |
| CHAPTER :10 Investigation of the Physico-Chemical Properties of Waste Water Effluents Chennai, Tamil Nadu, India. <i>Dr. S. Ramadevi</i> | 117 |
| References | 118 |

CHAPTER: 1
INTRODUCTION TO ECOSYSTEMS

Dr. T. Veeramani

Assistant professor, Department of Biotechnology,
Ponnaiyah Ramajayam Institute of Science
and Technology, Tamil Nadu, India.

Introduction

An ecosystem is a geographic area where plants, animals, and other organisms, as well as weather and landscape, work together to form a bubble of life. An ecosystem is a geographic area where plants, animals and other organisms, as well as weather and landscape, work together to form a bubble of life. Ecosystems contain biotic or living parts, as well as abiotic factors, or nonliving parts. Biotic factors include plants, animals and other organisms. Abiotic factors include rocks, temperature and humidity. Every factor in an ecosystem depends on every other factor, either directly or indirectly. A change in the temperature of an ecosystem will often affect what plants will grow there, for instance. Animals that depend on plants for food and shelter will have to adapt to the changes, move to another ecosystem, or perish. Ecosystems can be very large or very small. Tide pools, the ponds left by the ocean as the tide goes out, are complete, tiny ecosystems. Tide pools contain seaweed, a kind of algae, which uses photosynthesis to create food. Herbivores such as abalone eat the seaweed. Carnivores such as sea stars eat other animals in the tide pool, such as clams or mussels. Tide pools depend on the changing level of ocean water. Some organisms, such as seaweed, thrive in an aquatic environment, when the tide is in and the pool is full. Other organisms, such as hermit crabs, cannot live underwater and depend on the shallow pools left by low tides. In this way, the biotic parts of the ecosystem depend on abiotic factors. The whole surface of Earth is a series of connected ecosystems. Types of Ecosystem: Forest Ecosystem. A forest ecosystem consists of several plants, particularly trees, animals and microorganisms that live in coordination with the abiotic factors of the environment. Grassland Ecosystem, Tundra Ecosystem, Desert Ecosystem, Freshwater Ecosystem, Marine Ecosystem etc.

CHAPTER: 2

THE EFFECTS OF TECHNOLOGY AND ENVIRONMENTAL POLLUTION ON BIODIVERSITY CONSERVATION

Dr. T. Veeramani

Assistant professor, Department of Biotechnology,
Ponnaiyah Ramajayam Institute of Science
and Technology, Tamil Nadu, India.

Introduction

Wetland biodiversity is a major area of environmental concern. Wetland biodiversity loss issues have been raised as an important national and global issue for many years due to lack of integrated policy, proper use of advanced technology, institutional support, political commitment and lack of relevant stakeholder involvement. Biodiversity is in the vital field of environmental issues worldwide. Human beings suffer a mixture of environmental issues day by day.

Status of Environmental Concerns:

- (i) How food waste from visitors and others towards waterbody,
- (ii) Scarcity of dustbins adjacent visitor's area,
- (iii) Lack of sufficient environmental Notice Boards in different places,
- (iv) Absence of awareness on environmental education programme,
- (v) Sudden landslides from bordering hills,
- (vi) Uncontrolled use of polythene among stakeholders,
- (vii) Excessive use of wireless sensor devices among visitors, tourist guide, co-management team leader and young generations,
- (viii) Poor publicity on mike announcing and social media.

Species Diversity and Visitors' Activity

The study surveyed species including trees, fishes and birds, which as shown in Table 1 with local name, type, scientific name and present status. The status of these were declined gradually, some of them are critically endangered and vulnerable.

CHAPTER: 3
AN ANALYSIS OF THE INCREASE IN IRRIGATED AREA UNDER
GROUNDWATER

Dr. R. Arunkumar

Assistant professor, Department of Biotechnology,
Ponnaiyah Ramajayam Institute of Science
and Technology, Tamil Nadu, India.

Introduction

Irrigation is one of the important inputs for enhancing the level of productivity of crops. Today human civilization cannot be thought without groundwater. The total fresh water used for human activity is drawn partly from surface water and partly from ground water sources. In India, the aggregate replenishable groundwater potential has been estimated to be 431 km³ per year. Out of total groundwater potential, 71 km³ of water is used for industrial and domestic purposes. (Sengupta, R. 2001). Water requirement of one third of world population is met up by rechargeable ground water sources. So, it is quite natural for human society to be much concerned with reasonable use of it. Question arises as to how reasonable use of groundwater is determined. There is inter-generational difference in the use of groundwater. Moreover, there is disparity in the use of ground water between developing and developed economies. There is also intra-economy difference in the use of it. On per capita basis use of ground water for domestic purpose is higher in urban society than in rural society. Each of the households either in urban and rural areas has no equal access to this important natural resources. Use of groundwater is increasing for domestic and production purposes. Groundwater is being widely used for crop production. Undoubtedly agricultural productivity of irrigated land is higher than that of un-irrigated land. Use of surface water is declining and ground water is increasingly used in crop production. Area of agricultural land is at low ebb owing to its increased allocation for non-agricultural purposes. On the other hand, increase in population calls for expansion of agricultural output. This is not possible without use of irrigation water either from water bodies on the surface or from the stock of ground water. Considering the interest of both present

CHAPTER: 4

AVAILABILITY IN INDIA'S VARIOUS IRRIGATION SOURCES: A STATISTICAL METHOD

Dr. J. Ilamathi

Assistant professor, Department of Biotechnology,
Ponnaiyah Ramajayam Institute of Science
and Technology, Tamil Nadu, India.

Introduction

The Irrigation is the artificial application of water for the cultivation of crops, trees, grasses and so on. For a typical Indian farmer, looking up to the skies to see whether the rain gods will favour him this time, irrigation means a wide range of interventions at the farm level, ranging from a couple of support watering(s) (or 'life saving' watering) during the kharif (monsoon) season from a small check dam/pond/tank/dry well to assured year-round water supply from canals or tube wells to farmers cultivating three crops a year. The method of application has also evolved, from traditional gravity flow and farm flooding to micro-irrigation where water is applied close to the root zone of the plant. Indian farmers gain access to irrigation from two sources—surface water (that is, water from surface flows or water storage reservoirs) and groundwater (that is, water extracted by pumps from the groundwater aquifers through wells, tube wells and so on). Surface irrigation is largely provided through large and small dams and canal networks, run-off from river lift irrigation schemes and small tanks and ponds.

Canal networks are largely gravity-fed while lift irrigation schemes require electrical power. Groundwater irrigation is accessed by dug wells, bore wells, tube wells and is powered by electric pumps or diesel engines. To meet the growing needs of irrigation, the government and farmers have largely focused on a supply side approach rather than improve the efficiency of existing irrigation systems. Irrigation is the artificial application of water to the land or soil. It is used to assist in the growing of agricultural crops, maintenance of landscapes, and revegetation of disturbed soils in dry areas and during periods of inadequate rainfall. Irrigation has been a central feature

CHAPTER: 5

GROUNDWATER'S SIGNIFICANCE IN HARMONIZING WITH THE ENVIRONMENT

Dr. T. Veeramani

Assistant professor, Department of Biotechnology,
Ponnaiyah Ramajayam Institute of Science
and Technology, Tamil Nadu, India.

Introduction

For human usage, groundwater is extremely valuable and frequently comes from abundant sources. However, it may result in significant issues for the environment and society. It has ecological significance as well. The importance of groundwater and even of fresh water to Ecosystem is often overlooked by biologists and ecologists. Groundwater is a prime natural resource in the Earth. It not only supports all types of life forms to exist in the Earth but also helps in the growth of human civilization. It quenches thirst and fulfils all the house-hold demands. Groundwater is used for the irrigation purposes. The newly growing up industries catering to the various needs and luxuries of people consume volumes of water for their use. Arsenic contamination of groundwater is often due to naturally occurring high concentrations of arsenic in deeper levels of groundwater. A high profile problem arises because the use of deep-tube wells for water supply in the Ganges Delta causes serious arsenic poisoning to a large number of people. In the beginning, water from rainfall, snow and rivers was the only source of water to mankind. As these surface water sources were dependent on rainfall, local shortage was often witnessed. But men were not able to build sustainable water reservoir which can be useful for them in the drought period. Then, man came to know about groundwater and his dependence on it increased with the progress in civilization. At present about two billion people in the world are dependent on groundwater. Groundwater is highly useful and often with abundant sources and it is highly useful for the human beings. But it can cause major problems to the society and environment. It is also ecologically important. The importance of groundwater and even of fresh water to Ecosystem is often overlooked by biologists and ecologists.

CHAPTER: 6

BACTERIA AS POLLUTION INDICATORS IN THE ENVIRONMENT

Dr. Arjunpandian

Assistant professor, Department of Biotechnology,
Ponnaiyah Ramajayam Institute of Science
and Technology, Tamil Nadu, India.

Introduction

Environment is not only spatial place for human but also landfill for their waste which generated from their activity. Environment has the ability to revive the situation and neutralize its own condition and restore their initial state, if the waste is below the threshold of environment carrying capacity. Environment accommodates the waste from households and industry. This leads to the changes on environmental quality of water, soil and air that also affect on the flora, fauna and microorganisms life. The type and number of microorganisms in the environment is influenced by environment characteristic and waste that flow into the environment. It either inhibits or stimulates the growth of microorganisms. The environment quality of water, soil and air is degraded increasingly. Therefore we need to raise the prevention of pollution by monitoring environmental quality. There were several monitoring methods on the environmental quality, especially biological method. Biological methods assess the presence of several species, such as plants, insects, fish, bacteria and viruses as environmental indicator. Some species of bacteria have been used as indicators in monitoring environmental quality, e.g. Coliform, *Escherichia coli*, *Streptococcus* sp., *Pseudomonas* sp., *Vibrio* sp., *Clostridia* sp., *Bifidobacterium pseudolongum*, *Arcobacter* sp., *Thiobacillus* sp., and etc. The bacteria act as an indicator of household waste (human and animal feces, household waste and other), heavy metal pollution, crude oils and other pollution. Several studies have been conducted to assess the ecosystem quality of the river, lake and ocean using sophisticated and expensive equipment thus rarely done by the community. Therefore, several less expensive and easier methods have been developed, e.g. Biolitic method.

CHAPTER: 7
GLOBAL MARINE ECOSYSTEM

Dr. C. Anitha

Assistant professor, Department of Biotechnology,
Ponnaiyah Ramajayam Institute of Science
and Technology, Tamil Nadu, India.

Introduction:

The marine ecosystem in the global ocean represented by fish landings, exhibits the phase reversals of long-term variations like a 'regime shift'; an abrupt transition from one quasi-steady state to another, with the transition period much shorter than the length of the individual epochs of each systemic state. The ecosystem regime shifts are associated with large, abrupt, persistent changes in both atmospheric and oceanic conditions that may be especially pronounced in physical and biological variables. Generally, regime shifts were found in 1925, 1947, 1977, 1989, 1998[1][2][3][4]. The best single test case is the 1976/77 regime shift that has been identified in the literature numerous times from a variety of both data sets and analysis approaches[5][6]. Regime shifts in fish populations are difficult to explain on the basis of biological relationships alone [7][8]. Lehodey et al.[8] stated that fish population variability is closely related to environmental variability. In recent years numerous long-term changes in physical forcing have been observed at global, regional and basin scales as a result of climate and other anthropogenic changes. Impacts of these on biological processes supporting fish production in marine ecosystems have already been observed and may be used as proxies to estimate further global climate change impacts. These physical factors include atmospheric circulation and oceanic environmental (water temperature, ocean currents, coastal upwelling, etc) variability patterns. In this research, the key issue is to find the physical changes in relation to the regime shift in the global ecosystem and fisheries, and provide a more detailed analysis of how physical changes in the coupled atmospheric and oceanic conditions on the ocean surface may connect to the fisheries over the global ocean areas. The goal is to develop a global concept for the variability of large biological populations and their associated ecosystems by connecting them with

CHAPTER: 8

USING GEO-INFORMATION SYSTEMS IN ASSESSING WATER QUALITY

Dr. T. Veeramani

Assistant professor, Department of Biotechnology,
Ponnaiyah Ramajayam Institute of Science
and Technology, Tamil Nadu, India.

Introduction

The geo-information systems based method and primary data to assess the status of water quality trends in an agricultural watershed in the Maryland area of the Mid-Atlantic region. Emphasis is on the issues, current efforts, factors, and a case study to demonstrate the trend and future line of actions. The applications of geo-information system can be helpful in detecting land use practices that threaten the quality of agricultural watersheds [1]. It has the potentials to enhance the design of viable frameworks for the efficient management of water resources in stressed environments with the latest advances in spatial technologies [2, 3, 4]. In the literature, the vital roles of riparian buffers within agricultural watersheds in protecting biodiversity are highlighted in numerous studies [5]. However, in the Mid-Atlantic region of the state of Maryland where agriculture ranks as a leading industry and a major user of land, water quality issues from the sector continue to be a major problem.

In the study area, the Chesapeake Bay watershed and other river systems in the state are threatened by various anthropogenic stressors [6]. Pesticides as an essential part of those stressors that are occasionally ignored pose enormous danger to the health of stream habitat species and the local communities [7]. While nutrient overloading duly garner much of the interest now, current studies indicate that pesticide residues are not only found all through the Chesapeake watershed, but they surpass permissible levels set under water quality standards. In the Bay, where agriculture stands as a key source of pesticide and nutrient pollution of streams [8], the continuous discharge of surplus nutrients into the estuary constitutes a major hazard to the surrounding

CHAPTER: 9

THEOREM FOR IDEAL BIODIVERSITY AND ECOSYSTEM PERFORMANCE

Dr. C. Anitha

Assistant professor, Department of Biotechnology,
Ponnaiyah Ramajayam Institute of Science
and Technology, Tamil Nadu, India.

Introduction

The relationship between biodiversity and ecological functioning has been a focus of ecological research for a long period of time. The results of experimental, observational and theoretical investigations demonstrate that this interrelation is a significant phenomenon and is of crucial importance in nature protection theory and practice [1 - 6]. D. Tilman [1] points out that diversity must now be added to the list of factors that influence ecosystem functioning. In our opinion, extremal principles may lead to considerable benefits in the investigations of interconnections between ecosystem properties and diversity. According to these principles, biosystems have a tendency to reach only such states when their important characteristics associated with the survival, viability and development are extremal (maximum or minimum depending on their positive or negative values), for example, the maximum energy efficiency of an organism, the minimum mortality in the population, the maximum total biomass of the community, etc. These indicators of viability are called optimality criteria. Optimized characteristics of biosystems are adjusted such as to achieve the extreme values of the optimality criteria. The extremal principles have got wide distribution in biology. There are a lot of examples of their successful application in physiology, biochemistry, embryology, evolution theory, population dynamics, and ecology. However, in the field of biodiversity research, the capacities of this method have not been used in full measure. Optimization of intrapopulation diversity can occur primarily due to changes in the diversity of offspring (Figure 2). This parameter depends on the level of genetic diversity in the population and the average width of the reaction norm. "Tuning" diversity within the reaction norm does not require genetic changes and is the most labile

CHAPTER: 10
INVESTIGATION OF THE PHYSICO-CHEMICAL PROPERTIES OF WASTE
WATER EFFLUENTS IN CHENNAI, TAMIL NADU, INDIA.

Dr. S. Ramadevi

Assistant professor, Department of Biotechnology,
Ponnaiyah Ramajayam Institute of Science
and Technology, Tamil Nadu, India.

Introduction

Waste management strategies adopted in India have failed to keep pace with the industrial growth and urbanization. The pollution impacts on marine communities [1,2] can be traced directly to the industrialized centers, which release an array of chemical contaminants to effluent systems. Of even greater concern have been the adverse environmental effects associated with waste disposal activities, particularly sewage sludge and dredged spoil dumping, oil spills and leakages as well as municipal and industrial waste water discharges. Most of the industries in India are situated along the river banks for easy availability of water and also disposal of the wastes. These wastes often contain a wide range of contaminants such as petroleum hydrocarbons, chlorinated hydrocarbons and heavy metals, various acids, alkalis, dyes and other chemicals which greatly change the physico-chemical properties of water. The waste also includes detergents that create a mass of white foam in the river waters. All these chemicals are quite harmful or even fatally toxic to fish [1-3] and other aquatic populations [4]. It is found that one-third of the total water pollution in India comes in the form of industrial effluent discharge, solid wastes and other hazardous wastes. Out of this, a large portion can be traced to the processing of industrial chemicals and to the food products industry. The surface water is the main source of industries for waste disposal. Untreated or allegedly treated effluents have increase the level of surface water pollution up to 20 times the safe level in 22 critically polluted areas of the country.

NATURE OF ENVIRONMENTAL STUDIES

Edited by :

DR. S. RAMADEVI



978-93-6255-029-3

NATURE OF ENVIRONMENTAL STUDIES

Copyright © 2023 by Dr. S. Ramadevi

All rights reserved. No part of this book may be reproduced or transmitted in any form or by any means without written permission from the author.

ISBN: 978-93-6255-029-3

Publisher: Ponnaiyah Ramajayam Institute of Science and Technology (PRIST)

TABLE OF THE CONTENTS

| | |
|--|-----|
| Chapter:1 Nature of Environmental Studies..... <i>Dr. S. Ramadevi</i> | 1 |
| Chapter: 2 Policy and Management..... <i>Dr. T.Veeramani</i> | 15 |
| Chapter:3 Ethical Considerations <i>Dr. C. Anitha</i> | 28 |
| Chapter:4 Terdisciplinary Approach..... <i>Dr. J. Illamathi</i> | 35 |
| Chapter:5 Environmental Studies..... <i>Dr. T. Veeramani</i> | 41 |
| Chapter:6 Problem Solving <i>Dr. R. Kamaraj</i> | 54 |
| Chapter: 7 Community Engagement..... <i>Dr. Ramadevi</i> | 67 |
| Chapter: 8 Social Sciences <i>Dr. R. Arunkumar</i> | 78 |
| Chapter: 9 Holistic Perspective..... <i>Dr. A. Shajahan</i> | 85 |
| Chapter: 10 Human Impact..... <i>Dr. Arjunpandian</i> | 98 |
| References | 107 |

Chapter:1
Nature of Environmental Studies
Dr. S. Ramadevi
Department of Biotechnology,
Bon secours college for women, Thanjavur, Tamil Nadu

Nature of Environmental Studies

Environmental studies an interdisciplinary field that examines the intricate relationships between humans and their environment. It encompasses a wide range of topics, integrating knowledge from various disciplines to address the complex challenges posed by environmental degradation, resource depletion, and climate change. This comprehensive approach is essential for understanding the multifaceted nature of environmental issues and developing effective solutions.

1. Interdisciplinary Approach

One of the defining characteristics of environmental studies is its interdisciplinary nature. This field draws upon insights from multiple disciplines, including:

- **Natural Sciences:** These provide the foundational understanding of ecological systems, biological diversity, and the physical and chemical processes that govern the environment. For example, ecology helps in understanding ecosystems and biodiversity, while chemistry informs us about pollutants and their interactions with the environment.
- **Social Sciences:** Environmental studies also incorporates perspectives from sociology, anthropology, and psychology to analyze human behavior, cultural values, and social structures that influence environmental decision-making and policy development.
- **Economics:** Understanding the economic implications of environmental policies is crucial. Environmental economics evaluates the costs and benefits of environmental actions, addressing issues such as market failures, externalities, and the valuation of ecosystem services.
- **Political Science:** Environmental policy and governance are critical areas of focus. This discipline explores how political institutions, processes, and power dynamics shape environmental legislation, regulation, and enforcement.

By integrating these diverse perspectives, environmental studies provides a holistic understanding of environmental issues, enabling more effective problem-solving strategies.

Chapter: 2

Policy and Management

Dr. T.Veeramani

Assistant Professor, Department of Biotechnology,
Ponnaiyah Ramajayam Institute of Science
and Technology, Tamil Nadu, India

Environmental studies often involve formulating policies and strategies to manage natural resources and protect ecosystems. This includes:

- **Conservation Efforts:** Developing strategies for the conservation of biodiversity and natural habitats. This may involve creating protected areas, restoring degraded ecosystems, and implementing sustainable land management practices.
- **Resource Management:** Creating frameworks for the sustainable management of natural resources, including water, forests, and fisheries. This involves balancing ecological health with human needs.

Environmental Law: Understanding and developing legal frameworks that govern environmental protection and resource use. This includes local, national, and international laws aimed at safeguarding the environment. **Public Participation:** Encouraging the involvement of local communities in environmental decision-making processes. This ensures that policies are reflective of local needs and knowledge.

Education and Awareness: Promoting environmental education to raise awareness about environmental issues and inspire action. Education empowers individuals and communities to make informed decisions and adopt sustainable practices.

Collaboration: Fostering partnerships between governments, NGOs, businesses, and communities to address environmental challenges collectively. Collaboration enhances the effectiveness of environmental initiatives and promotes shared responsibility.

Environmental studies often involves formulating policies and strategies to manage natural resources and protect ecosystems. This includes:

- **Conservation Efforts:** Developing strategies for the conservation of biodiversity and natural habitats. This may involve creating protected areas, restoring degraded ecosystems, and implementing sustainable land management practices.
- **Resource Management:** Creating frameworks for the sustainable management of natural resources, including water, forests, and fisheries. This involves balancing ecological health with human needs.
- **Environmental Law:** Understanding and developing legal frameworks that govern environmental protection and resource use. This includes local, national, and international laws aimed at safeguarding the environment.

Chapter:3
Ethical Considerations
Dr. C. Anitha

Marudupandiyar college, Thanjavur, Tamil Nadu

Environmental studies encompass ethical considerations regarding the environment. This includes:

- **Environmental Justice:** Addressing inequalities in environmental protection and resource access. Environmental studies advocates for marginalized communities disproportionately affected by environmental degradation and seeks to ensure equitable distribution of environmental benefits.
- **Intergenerational Responsibility:** Considering the rights of future generations in current environmental decision-making. This ethical perspective emphasizes the need for sustainable practices that preserve the planet for those who come after us.

Intrinsic Value of Nature: Recognizing the inherent value of nature and biodiversity, irrespective of their utility to humans. This perspective encourages a respectful and ethical relationship with the natural world. **Conservation Efforts:** Developing strategies for the conservation of biodiversity and natural habitats. This may involve creating protected areas, restoring degraded ecosystems, and implementing sustainable land management practices.

Resource Management: Creating frameworks for the sustainable management of natural resources, including water, forests, and fisheries. This involves balancing ecological health with human needs.

- **Pollution:** Investigating the sources, effects, and mitigation strategies for various forms of pollution, including air, water, and soil pollution. This research is vital for informing regulations and public health initiatives.
- **Climate Change:** Addressing the causes and impacts of climate change, including greenhouse gas emissions, rising sea levels, and extreme weather events. Environmental studies plays a critical role in understanding and mitigating these effects.
- Ensuring that all members of society have access to resources, opportunities, and a healthy environment is crucial for social equity. Environmental studies addresses issues of environmental justice, advocating for marginalized communities disproportionately affected by environmental degradation. Environmental studies adopts a holistic perspective, recognizing that natural and human systems are interconnected.

Chapter: 4 Terdisciplinary Approach

Dr. J. Illamathi

Assistant Professor, Department of Biotechnology,
Ponnaiyah Ramajayam Institute of Science
and Technology, Tamil Nadu, India

Introduction:

One of the primary characteristics of environmental studies is its interdisciplinary nature. The field draws upon knowledge from diverse disciplines to understand the multifaceted nature of environmental issues.

1. **Natural Sciences:** Environmental studies relies heavily on natural sciences, including ecology, biology, and chemistry. These disciplines provide essential insights into ecological processes, biodiversity, and the chemical interactions that occur within ecosystems. For example, ecology helps scientists understand how species interact within their habitats, while chemistry informs us about pollutants, their sources, and their impacts on ecosystems and human health.
2. **Social Sciences:** The integration of social sciences is crucial for understanding human behavior and societal structures that influence environmental policies and practices. Sociology examines how social norms, values, and institutions shape environmental attitudes and actions, while anthropology explores the cultural dimensions of environmental interactions. Psychology also plays a role in understanding how people perceive environmental risks and make decisions about resource use.

3. NATURE OF ENVIRONMENTAL STUDIES

Environmental studies is an interdisciplinary field that focuses on the relationship between humans and the environment, exploring how various factors influence ecological systems and vice versa. Here are some key aspects of the nature of environmental studies:

1. **Interdisciplinary Approach:** It integrates knowledge from various disciplines such as ecology, biology, chemistry, geography, sociology, economics, and political science to understand environmental issues comprehensively.
2. **Holistic Perspective:** Environmental studies considers the environment as a complex and interconnected system, emphasizing the interplay between natural and human systems.
3. **Focus on Sustainability:** A primary goal is to promote sustainable practices that balance human needs with environmental protection, ensuring resources are available for future generations.

Chapter: 5 Environmental Studies

Dr. T. Veeramani

Assistant Professor, Department of Biotechnology,
Ponnaiyah Ramajayam Institute of Science
and Technology, Tamil Nadu, India.

Introduction:

Environmental studies is an interdisciplinary field that examines the intricate relationships between humans and their environment. It encompasses a wide range of topics, integrating knowledge from various disciplines to address the complex challenges posed by environmental degradation, resource depletion, and climate change. This comprehensive approach is essential for understanding the multifaceted nature of environmental issues and developing effective solutions.

1. Interdisciplinary Approach

One of the defining characteristics of environmental studies is its interdisciplinary nature. This field draws upon insights from multiple disciplines, including:

- **Natural Sciences:** These provide the foundational understanding of ecological systems, biological diversity, and the physical and chemical processes that govern the environment. For example, ecology helps in understanding ecosystems and biodiversity, while chemistry informs us about pollutants and their interactions with the environment.
- **Social Sciences:** Environmental studies also incorporates perspectives from sociology, anthropology, and psychology to analyze human behavior, cultural values, and social structures that influence environmental decision-making and policy development.
- **Economics:** Understanding the economic implications of environmental policies is crucial. Environmental economics evaluates the costs and benefits of environmental actions, addressing issues such as market failures, externalities, and the valuation of ecosystem services.
- **Political Science:** Environmental policy and governance are critical areas of focus. This discipline explores how political institutions, processes, and power dynamics shape environmental legislation, regulation, and enforcement.

By integrating these diverse perspectives, environmental studies provides a holistic understanding of environmental issues, enabling more effective problem-solving strategies.

Chapter: 6
Problem Solving

Dr. R. Kamaraj

Assistant Professor, Department of Biotechnology,
Ponnaiyah Ramajayam Institute of Science
and Technology, Tamil Nadu, India.

Introduction

Environmental studies is fundamentally oriented toward problem-solving. It aims to identify, analyze, and propose solutions to pressing environmental issues. This involves:

- **Research and Analysis:** Conducting research to understand the causes and consequences of environmental problems, such as climate change, pollution, and habitat destruction. This analysis often involves data collection, modeling, and predictive assessments.
- **Policy Development:** Developing policies and regulations that address environmental challenges. This may include creating protected areas, setting emissions standards, and promoting sustainable land use practices.
- **Community Engagement:** Collaborating with communities to implement solutions that are context-specific and culturally sensitive. Engaging local stakeholders ensures that solutions are practical and widely accepted.

1. Human Impact

A central focus of environmental studies is the examination of human impact on the environment. This includes:

- **Resource Consumption:** Analyzing patterns of consumption and production, particularly in industrialized societies, which often lead to resource depletion and environmental degradation. Understanding these patterns is crucial for developing strategies to promote sustainable consumption.
- **Pollution:** Investigating the sources, effects, and mitigation strategies for various forms of pollution, including air, water, and soil pollution. This research is vital for informing regulations and public health initiatives.
- **Climate Change:** Addressing the causes and impacts of climate change, including greenhouse gas emissions, rising sea levels, and extreme weather events.

2. Policy and Management

Environmental studies often involves formulating policies and strategies to manage natural resources and protect ecosystems. This includes:

- **Conservation Efforts:** Developing strategies for the conservation of biodiversity and natural habitats. This may involve creating protected areas, restoring degraded ecosystems, and implementing sustainable land management practices.

Chapter: 7 Community Engagement

Dr. Ramadevi

Assistant Professor, Department of Biotechnology,
Ponnaiyah Ramajayam Institute of Science
and Technology, Tamil Nadu, India

Introduction:

Community engagement is a crucial component of environmental studies. This involves:

- **Public Participation:** Encouraging the involvement of local communities in environmental decision-making processes. This ensures that policies are reflective of local needs and knowledge.
- **Education and Awareness:** Promoting environmental education to raise awareness about environmental issues and inspire action. Education empowers individuals and communities to make informed decisions and adopt sustainable practices.
- **Collaboration:** Fostering partnerships between governments, NGOs, businesses, and communities to address environmental challenges collectively. Collaboration enhances the effectiveness of environmental initiatives and promotes shared responsibility.

Ethical Considerations

Environmental studies encompass ethical considerations regarding the environment. This includes:

- **Environmental Justice:** Addressing inequalities in environmental protection and resource access. Environmental studies advocate for marginalized communities disproportionately affected by environmental degradation and seeks to ensure equitable distribution of environmental benefits.
- **Intergenerational Responsibility:** Considering the rights of future generations in current environmental decision-making. This ethical perspective emphasizes the need for sustainable practices that preserve the planet for those who come after us.
- **Intrinsic Value of Nature:** Recognizing the inherent value of nature and biodiversity, irrespective of their utility to humans. This perspective encourages a respectful and ethical relationship with the natural world.

Chapter: 8

Social Sciences

Dr. R. Arunkumar

Assistant Professor, Department of Biotechnology,
Ponnaiyah Ramajayam Institute of Science
and Technology, Tamil Nadu, India

The integration of social sciences is crucial for understanding human behavior and societal structures that influence environmental policies and practices. Sociology examines how social norms, values, and institutions shape environmental attitudes and actions, while anthropology explores the cultural dimensions of environmental interactions. Psychology also plays a role in understanding how people perceive environmental risks and make decisions about resource use.

1. **Economics:** Environmental economics is a critical component of environmental studies, focusing on the economic implications of environmental policies and practices. It analyzes the costs and benefits of environmental actions, evaluates market failures, and explores the valuation of ecosystem services. By understanding the economic factors that drive environmental degradation, policymakers can develop more effective strategies for promoting sustainable practices.

Political Science: **Nature of Environmental Studies**

Environmental studies is an interdisciplinary academic field that explores the complex interactions between humans and the environment. It integrates concepts and methodologies from various disciplines, including ecology, biology, chemistry, geography, sociology, economics, and political science, to develop a comprehensive understanding of environmental issues. The nature of environmental studies is multifaceted, characterized by its holistic approach, focus on sustainability, emphasis on problem-solving, and incorporation of ethical considerations. This field aims to analyze and address pressing environmental challenges through research, policy development, and community engagement. on the economic implications of environmental policies and practices. It analyzes the costs and benefits of environmental actions, evaluates market failures, and explores the valuation of ecosystem services. By understanding the economic factors that drive environmental degradation, policymakers can develop more effective strategies for promoting sustainable practices. he integration of social sciences is crucial for understanding human behavior and societal structures that influence environmental policies and practices. Sociology examines how social norms, values, and institutions shape environmental attitudes and actions, while anthropology explores the cultural dimensions of environmental interactions. Psychology also plays a role in understanding how people perceive environmental risks and make decisions about resource use.

Chapter: 9

Holistic Perspective

Dr. A. Shajahan

Associate Professor, Department of Biotechnology,
Ponnaiyah Ramajayam Institute of Science
and Technology, Tamil Nadu, India

Introduction:

Environmental studies adopt a holistic perspective, recognizing that natural and human systems are interconnected. This viewpoint emphasizes that changes in one part of the system can have far-reaching effects on other components. For example, deforestation can lead to soil erosion, loss of biodiversity, and altered climate patterns, which, in turn, can affect agricultural productivity and human livelihoods. A holistic approach encourages researchers and policymakers to consider the broader implications of environmental actions and to seek solutions that address multiple facets of a problem simultaneously.

Focus on Sustainability

At the heart of environmental studies lies the concept of sustainability. The field seeks to promote practices that meet the needs of the present without compromising the ability of future generations to meet their own needs. Sustainability encompasses three main pillars:

1. **Environmental Sustainability:** This pillar focuses on the protection of natural ecosystems, conservation of biodiversity, and sustainable use of resources. Environmental sustainability emphasizes the importance of maintaining the health of the planet and its ecosystems for current and future generations. This involves implementing practices that minimize environmental impact, such as reducing waste, conserving water, and protecting habitats.
2. **Economic Sustainability:** Economic sustainability aims to create economic systems that can endure over time while minimizing negative environmental impacts. This involves promoting green technologies, sustainable agriculture, and renewable energy sources. Economic sustainability recognizes that economic growth should not come at the expense of environmental degradation and that a healthy economy relies on a healthy environment.
3. **Social Sustainability:** Social sustainability emphasizes the need for social equity and justice in environmental decision-making. It advocates for the inclusion of marginalized communities and consideration of their rights in environmental policies. Social sustainability ensures that all members of society have access to resources, opportunities, and a healthy environment, fostering community resilience and well-being.

Chapter: 10

Human Impact of Environment

Dr. Arjunpandian

Assistant Professor, Department of Biotechnology,
Ponnaiyah Ramajayam Institute of Science
and Technology, Tamil Nadu, India

A central focus of environmental studies is the examination of human impact on the environment. This includes:

1. **Resource Consumption:** Analyzing patterns of consumption and production is crucial for understanding how human activities contribute to resource depletion and environmental degradation. Industrialized societies, in particular, often exhibit unsustainable consumption patterns that strain natural resources. Understanding these patterns helps identify opportunities for promoting sustainable consumption and reducing ecological footprints.
2. **Pollution:** Investigating the sources and effects of pollution is a key area of research within environmental studies. This includes air, water, and soil pollution, which can have serious health and ecological consequences. Understanding the impacts of pollutants informs regulatory measures and public health initiatives aimed at mitigating pollution and protecting ecosystems.
3. **Climate Change:** Addressing climate change is one of the most pressing challenges of our time. Environmental studies examine the causes of climate change, including greenhouse gas emissions from human activities, and explores its far-reaching impacts on ecosystems, weather patterns, and human livelihoods. The field plays a critical role in understanding and developing strategies for climate adaptation and mitigation.

ADVANCE BIOTECHNOLOGY

EDITED BY

DR. T. VEERAMANI



978-93-6255-778-0

ADVANCE BIOTECHNOLOGY

Copyright©2023 By Dr. T. Veeramani

All rights reserved. No part of this book may be reproduced or transmitted in any form or by any means without written permission from the author.

ISSN: 978-93-6255-778-0

Publisher: Ponnaiyah Ramajayam Institute of Science and Technology (PRIST)

TABLE OF THE CONTENTS

| | |
|--|-----|
| CHAPTER :1 Introduction to Biotechnology..... | 1 |
| <i>Dr. T. Veeramani</i> | |
| CHAPTER :2 The fundamentals, difficulties, and developments of ribosome profiling: from large-scale to low-volume and single-cell investigation..... | 14 |
| <i>Dr. T. Veeramani</i> | |
| CHAPTER :3 Water-saving methods: crop physiological reactions and regulatory systems..... | 25 |
| <i>Dr. R. Arunkumar</i> | |
| CHAPTER :4 Advanced Biotechnology to improve biotechnology research in a variety of fields, including agriculture and biomedicine..... | 31 |
| <i>Dr. J. Ilamathi</i> | |
| CHAPTER :5 Methods to increase the resilience of microbial cell factories..... | 48 |
| <i>Dr. T. Veeramani</i> | |
| CHAPTER :6 <i>Methods for examining biomolecular condensates that have separated into phases.....</i> | 59 |
| <i>Dr. Arjunpandian</i> | |
| CHAPTER :7 Ammoniacal odour elimination bioagent's effects on the bacterial community in the air..... | 68 |
| <i>Dr. T. Veeramani</i> | |
| CHAPTER :8 Utilizing images from mass spectrometry in botanical research..... | 79 |
| <i>Dr. T. Veeramani</i> | |
| CHAPTER :9 Value of pre-mRNA splicing research instruments in plants..... | 94 |
| <i>Dr. C. Anitha</i> | |
| CHAPTER :10 Impact of water ammonia nitrogen on the gut microbiota and hemolymph of <i>Litopenaeus vannamei</i> | 109 |
| <i>Dr. S. Ramadevi</i> | |
| References | 113 |

CHAPTER: 1

INTRODUCTION TO BIOTECHNOLOGY

Dr. T. Veeramani

Assistant professor, Department of Biotechnology,
Ponnaiyah Ramajayam Institute of Science
and Technology, Tamil Nadu, India

Introduction:

Karl Ereky, a Hungarian engineer, first used the term "biotechnology" in 1919 to describe the science and processes that enable goods to be made from raw materials with the help of living things. Biotechnology is a broad science that uses a variety of instruments and technologies to deal with living cells or compounds produced from them for applications aimed at improving human happiness. It is an integration of engineering and biological science in which products and services are produced using living things, their cells, or their pieces. The main subfields of biotechnology are medical (red) biotechnology, agricultural (green) biotechnology, industrial (white) biotechnology, marine (blue) biotechnology, food biotechnology, and environmental biotechnology. In this chapter the readers will understand the potential applications of biotechnology in several fields like production of medicines; diagnostics; therapeutics like monoclonal antibodies, stem cells, and gene therapy; agricultural biotechnology; pollution control (bioremediation); industrial and marine biotechnology; and biomaterials, as well as the ethical and safety issues associated with some of the products. The biotechnology came into being centuries ago when plants and animals began to be selectively bred and microorganisms were used to make beer, wine, cheese, and bread. However, the field gradually evolved, and presently it is the use or manipulation of living organisms to produce beneficiary substances which may have medical, agricultural, and/or industrial utilization. Conventional biotechnology is referred to as the technique that makes use of living organism for specific purposes as bread/cheese making, whereas modern biotechnology deals with the technique that

CHAPTER: 2

THE FUNDAMENTALS, DIFFICULTIES, AND DEVELOPMENTS OF RIBOSOME PROFILING: FROM LARGE-SCALE TO LOW-VOLUME AND SINGLE-CELL INVESTIGATION

Dr. T. Veeramani

Assistant professor, Department of Biotechnology,
Ponnaiyah Ramajayam Institute of Science
and Technology, Tamil Nadu, India

Introduction

The translation of mRNA typically begins with the recruitment of the preinitiation complex, which consists of the ribosomal small subunit, a ternary complex, and initiation factors, to the mRNAs usually marks the start of mRNA translation. A Shine-Dalgarno (SD) sequence that is 8–10 nucleotides (nt) upstream of the initiation site is typically how the preinitiation complex in prokaryotes is loaded onto the initiation site (Rodnina 2018). In contrast, the recruitment of eukaryotic ribosomes is more intricate and appears to be a rate-limiting step in translation (Hinnebusch 2014; Merrick and Pavitt 2018). In eukaryotes, the preinitiation complex is recruited to the 5' end of mRNA by recognizing the 5' m⁷G cap through the eukaryotic initiation factor eIF4E. The preinitiation complex then scans the 5' untranslated region (5' UTR) until an initiation site is recognized. A commonly known scanning model suggests that the first AUG encountered by the initiation complex serves as the initiation site. However, the fidelity of initiation site selection often involves intricate interactions between initiation factors and *cis* elements (Kozak 2005; Hinnebusch 2011, 2017; Llácer et al. 2018; Brito Querido et al. 2020; Gu et al. 2021; She et al. 2023). It is not uncommon for the initiation complex to bypass several AUG triplets in the 5' UTR through a mechanism known as leaky scanning (Kozak 1999; Dever et al. 2023). Moreover, in certain circumstances, CUG, GUG, and UUG, three other AUG-like triplets in the 5' UTR, can also serve as initiation codons, providing an extra degree of control to the process of choosing an initiation site (Starck et al. 2012; Hinnebusch et al. 2016).

CHAPTER: 3

WATER-SAVING METHODS: CROP PHYSIOLOGICAL REACTIONS AND REGULATORY SYSTEMS

Dr. R. Arunkumar

Assistant professor, Department of Biotechnology,
Ponnaiyah Ramajayam Institute of Science
and Technology, Tamil Nadu, India

Introduction:

The largest user of water in human society, irrigation plays a key role in raising crop yields and lessening the effects of drought (Wang et al., 2021a). But irrigation water is an expensive and limited resource, and the lack of water resources is a major danger to agriculture that is sustainable. Water-saving technologies are in higher demand as a result of this (Rao et al. 2016; Cheng et al. 2021a). Crop yield and water usage efficiency (WUE), which is often referred to as water productivity (WP) when utilized for yield, are directly correlated with irrigation level (Tong et al. 2022; García-Tejera et al. 2018; Bozkurt Çolak 2021). Presently, the primary factors causing a decline in crop output and quality are drought and water stress. Water-saving irrigation systems have steadily gained importance in recent years as a means of resolving the tension that exists between water usage and agricultural productivity (Chen et al., 2023). The two primary irrigation techniques used today are deficit irrigation (DI) and full irrigation (FI), with the latter permitting a certain degree of water deficit and the former needing a sufficient amount of water to irrigate plants (Peake et al. 2016; Wen et al. 2018). These two separate irrigation tactics (FI and DI) have led to the development of numerous specialized water-saving irrigation techniques in order to fulfill varying water-saving requirements and accommodate various crops.

Water-saving irrigation techniques in crops are closely associated with WUE, grain yield, treatment, and farmers, and their importance is steadily increasing, as observed simultaneously by running a keyword co-occurrence network analysis and a burst word detection analysis in the Web of Science Core Collection database (Figure S1). Furthermore, the findings indicate that rice, wheat, soybean, maize, and cotton are leading crops among these important ones. The bulk of the world's population is fed by these five crops, which are also the most extensively farmed worldwide (Hergert et al. 2016). Therefore, it is crucial to look into how these five crops are affected by water-saving irrigation systems.

CHAPTER: 4

ADVANCED BIOTECHNOLOGY TO IMPROVE BIOTECHNOLOGY RESEARCH IN A VARIETY OF FIELDS, INCLUDING AGRICULTURE AND BIOMEDICINE

Dr. J. Ilamathi

Assistant professor, Department of Biotechnology,
Ponnaiyah Ramajayam Institute of Science
and Technology, Tamil Nadu, India

Introduction:

The goal of Advanced Biotechnology is to advance agricultural and biomedical biotechnology research. The history of biotechnology is lengthy and intriguing, going all the way back to when prehistoric people employed techniques like fermentation and selective breeding to boost food production and enhance agricultural results. Modern biotechnology was made possible by significant advancements in molecular biology and genetics in the middle of the 20th century. In fact, the discovery of recombination DNA technology in the 1970s was a turning point since it allowed people to alter genes in whatever way they desired (Ishino and Ishino 2014). This important discovery resulted in the development of genetically modified organisms and the introduction of biopharmaceuticals made with recombinant DNA technology, such as insulin, which significantly altered the way diabetes was treated (Kurtzhals et al. 2021).

Biotechnology has had a genuinely revolutionary effect on both medicine and agriculture, providing new ways to improve agricultural output and human health while also meeting the increasing needs of a world population that is growing at an accelerating rate. These days, biotechnology is essential to solving world problems since it provides cutting-edge solutions for the medical and agricultural sectors. Biotechnology has transformed targeted pharmacological therapy and enhanced diagnostics in medicine, allowing for the treatment of hereditary ailments that were previously incurable and increasing patient outcomes. Notably, the development of several vaccinations has been made possible by the manufacturing of recombinant proteins and monoclonal antibodies, demonstrating the potential of biotechnology to address developing health issues. Biotechnology in agriculture has sparked the development of plant varieties with improved tolerance to pests, illnesses, and

CHAPTER :5

METHODS TO INCREASE THE RESILIENCE OF MICROBIAL CELL FACTORIES

Dr. T. Veeramani

Assistant professor, Department of Biotechnology,
Ponnaiyah Ramajayam Institute of Science
and Technology, Tamil Nadu, India

Introduction:

The creation of many sophisticated cell factories is made possible by metabolic engineering and synthetic biology, which work by introducing non-natural or heterologous biochemical pathways into host strains. Yeasts have demonstrated remarkable potential in the biosynthesis of numerous high-value active chemicals, from the de novo biosynthesis of xanthohumol (Yang et al. 2024) to the previous entire biosynthesis of opioids (Galanie et al. 2015). Several microorganisms, including *Zymomonas mobilis* (Wang et al. 2018), *Yarrowia lipolytica* (Park and Ledesma-Amaro 2023), and *Halomonas campaniensis* (Ling et al. 2019), have been engineered as important chassis cells to adapt to different application environments, in addition to model strains like *Saccharomyces cerevisiae* and *Escherichia coli*. This has been achieved with the help of powerful genome-editing tools.

Although the terms tolerance and robustness have occasionally been used interchangeably in industrial microbiological applications, robustness is a broader notion in microbiology. The ability of cells to proliferate or endure when subjected to one or more disturbances is known as tolerance or resistance. Usually, only growth-related metrics are used to characterize it (such as viability or specific growth rate). The ability of a strain to continue producing at a consistent level (titer, yield, and productivity) in the face of varying growth conditions is referred to as robustness. While the strain with better robustness has to have a higher tolerance, strains with higher tolerance may not always translate into higher yields. Thus, when designing microbial cell factories and expanding their production, one of the most crucial factors to take into account is enhancing the strain's resilience against adverse circumstances.

Through the coordinated regulation of several enzymes and pathways by various transcription factors in response to varying environmental conditions, cells have evolved to maximize cellular function.

CHAPTER: 6

METHODS FOR EXAMINING BIOMOLECULAR CONDENSATES THAT HAVE SEPARATED INTO PHASES

Dr. Arjunpandian

Assistant professor, Department of Biotechnology,
Ponnaiyah Ramajayam Institute of Science
and Technology, Tamil Nadu, India

Introduction

The conventional method of compartmentalization pertains to membrane-bound eukaryotic cell organelles, including mitochondria, lysosomes, and the nucleus. Membrane-less organelles, or biomolecular condensates, have gained prominence in the last ten years as a crucial type of compartmentalization. Numerous examples of these include germ granules (So et al. 2021), transcriptional hubs (Boijja et al. 2018), nucleolus (Pederson 2011), stress granules (Protter and Parker 2016), heterochromatin (Larson et al. 2017), and P bodies (Luo et al. 2018). Through systematic screens or coincidental discoveries, a growing number of biomolecular condensates are being found, and many more are still unidentified (Hou et al. 2023; Fong et al. 2013).

Protein and RNA components make up dozens, perhaps even hundreds, of the components in biomolecular condensates. According to recent studies, scaffolds are proteins or RNAs with a high phase separation capacity. Through interactions between these scaffolds and other proteins or RNAs, known as "clients," these proteins or RNAs are drawn to biomolecular condensates (Banani et al. 2016). As a result, according to Yang et al. (2020), biomolecular condensates are a complicated web of interactions between proteins and RNA.

Biomolecular condensates typically take on spherical shapes and have characteristics similar to liquid droplets. But according to current research, biomolecular condensates that resemble gels, glasses, or solids can form sheets or other amorphous structures. (Ma and Mayr 2018; Yu, et al. 2021; Yu, et al. 2021). The physiological roles of biomolecular condensates are intimately related to their characteristics. For instance, a longer shelf life or a pathogenic state are frequently linked to a more solid attribute (Patel et al. 2015). Moreover, biomolecular condensates frequently contain substructures; they are not homogenous structures. For example, a large number of condensates have surface-core or shell-like structures (Jain et al., 2016; Wan et al., 2021; Folkmann et al., 2021; Zhou., 2021).

CHAPTER: 7

AMMONIACAL ODOUR ELIMINATION BIOAGENT'S EFFECTS ON THE BACTERIAL COMMUNITY IN THE AIR

Dr. T. Veeramani

Assistant professor, Department of Biotechnology,
Ponnaiyah Ramajayam Institute of Science
and Technology, Tamil Nadu, India

Introduction

Concerns concerning possible effects on odors and bioaerosols were raised by ammoniacal odor and pathogenic bacteria in the air, which presented threats to the environment and human health (Qian et al. 2016). (Domingo and Nadal 2009; Robertson et al. 2019). As a result, cleaning the air in compost piles has become essential. Recent years have seen the exploration of a variety of air purification technologies, such as physical, chemical, and biological approaches, to remove pollutants from composting air systems (Yan et al. 2014; Wysocka et al. 2019). Notably, air purifying biotechniques have become popular subjects in current research due to their versatility, broad applicability, long-lasting benefits, and simplicity (Kim et al. 2004; Kim and Park 2006). Odorous materials were used as growth nutrients by microorganisms like yeast, lactobacillus, and Bacillus, which resulted in the production of metabolites like acetaldehyde and diacetyl as well as enzymes like lipases and proteases (Chen et al. 2016; Ma et al. 2021). These microbial compounds and enzymes have aromatic qualities that cover up smells while preventing gas-producing and dangerous microbes from growing (Kim et al. 2021).

Though research on biotechnologies for controlling air pollution has been relatively restricted in comparison to soil and water treatment, bioremediation technologies have grown quickly. This restriction is mostly caused by the lower levels of gas molecules and microbial biomass in the air, which are made worse by difficulties with the sampling procedure (Xie et al. 2021). Nonetheless, it is becoming more widely acknowledged that comprehending the connection between human health, the microbial ecology, and air quality is essential (Kan et al. 2012) and calls for more research. In-depth research is necessary to understand how air purification technologies affect microbial communities and clarify possible health dangers. These investigations ought to explore the ways in which microbial agents influence air microbial communities in order to facilitate the creation of more potent bioagents.

CHAPTER: 8

Utilizing images from mass spectrometry in botanical research

Dr. T. Veeramani

Assistant professor, Department of Biotechnology,
Ponnaiyah Ramajayam Institute of Science
and Technology, Tamil Nadu, India

Introduction

Plants are essential to human existence since they are a key source of food and medicine. As a result, botany has long been studied by scientists. Plants have a complex metabolic network that produces a variety of metabolites in a time- and space-defined way, including terpenoids, alkaloids, and polyphenols. Many of these metabolites have significant applications as medicinal molecules in addition to their critical roles in signal transduction, defense responses, and plant disease resistance. The relationships between the biosynthesis and transport of bioactive molecules in plants, as well as the interaction between the accumulation of secondary metabolites and environmental factors, can be better understood using conventional metabolomics technology. Mass spectrometry imaging (MSI) is a novel molecular imaging approach that was introduced by Caprioli et al. in 1997 to examine the spatial distribution of proteins and peptides in biological tissue samples. This method allows for in situ desorption/ionization of the target material within the sample by scanning it with a variety of ionization probes that have unique principles and architectures. A mass spectrometer is used to evaluate the desorbed or ionized material, producing a set of mass spectrograms that match the sample's spatial location. The set of mass spectra is then processed by mass imaging software to provide tissue distribution images for every mass-to-charge (m/z) ratio.

Multiple MSI technologies have been developed as a result of ongoing improvements in MSI technology and innovations to satisfy the different needs of many research disciplines. For use in plants, three MSI techniques have gained popularity: desorption electrospray ionization–mass spectrometry imaging (DESI-MSI) Cooks et al. 2006, secondary ion mass spectrometry (SIMS) imaging Q. B. Liu et al. 2022, Todd et al. 2001, and matrix-assisted laser desorption ionization–mass spectrometry imaging (MALDI-MSI) (Mi et al. 2020; Stoeckli et al. 2001).

CHAPTER: 9

Value of pre-mRNA splicing research instruments in plants

Dr. C. Anitha

Assistant professor, Department of Biotechnology,
Ponnaiyah Ramajayam Institute of Science
and Technology, Tamil Nadu, India

Introduction

In eukaryotes, premature-mRNA (Pre-mRNA) splicing is a crucial post-transcriptional regulation mechanism. Since Richard Roberts and Phillip Sharp discovered RNA splicing for the first time in 1977, it has been the subject of substantial research (Berget et al. 1977). As far as we now understand, eukaryotic genes are made up of noncoding (introns) and coding (exons) sequences. Pre-mRNA alternative splicing creates distinct transcripts with variable combinations by removing different introns and non-coding mRNA regions and combining corresponding coding sequences (Newman 1998; Gilbert 1978; Sharp 1987). Thus, AS can convert a single pre-mRNA into several mature transcripts, increasing genetic diversity. By altering the transcript to affect the stability or ratio of particular isoforms, AS can control the production of proteins (Wright). Up to 90% of the genes that make up the proteome in plants have introns, and between 42% and 61% of the genes go through AS (Shang et al. 2017). AS contributes more significantly to improving the diversity of mRNA transcripts than it does to proteome diversity (Chaudhary et al. 2019).

Furthermore, the amount of AS that contributes to the diversity of the plant proteome is less than that of humans (Montes et al. 2019). It has been noted that 30% of *Chlamydomonas* pre-mRNA undergoes AS, which is comparable to what happens in blooming plants (Labadorf et al. 2010). Splicing patterns in *Chlamydomonas reinhardtii* differ between phases as the organism moves through the cell cycle (Pandey et al. 2020). According to Chaudhary et al. (2019), AS is involved in a variety of functional processes in animals, including humans, including apoptosis and mRNA transcript concentration. As a result, a number of studies have demonstrated that unchecked AS can lead to illness, and numerous research investigating the potential use of AS in the treatment of certain illnesses, including cancer, have been published (Chaudhary et al. 2019; Montes et al. 2019; Su et al. 2023). In addition, AS heightens genomic instability—a factor strongly linked to the development of tumors (Rahmutulla et al. 2014). A crucial component of eukaryotic development is AS.

CHAPTER: 10

IMPACT OF WATER AMMONIA NITROGEN ON THE GUT MICROBIOTA AND HEMOLYMPH OF *LITOPENAEUS VANNAMEI*

Dr. S. Ramadevi

Assistant professor, Department of Biotechnology,
Ponnaiyah Ramajayam Institute of Science
and Technology, Tamil Nadu, India

Because of their high protein content and important nutrients, aquatic foods—also known as "Blue Foods"—that are harvested from or grown in aquatic ecosystems have gained a lot of attention globally (Naylor et al., 2021). In the aquaculture sector, the Pacific white shrimp (*Litopenaeus vannamei*, *L. vannamei*) is becoming a more significant aquatic commercial species. Intensive farming becomes the primary source of many essential crustacean species because rising seafood consumption necessitates higher yields in aquatic products (Food and Agriculture Organization of the United Nations, 2020). However, extensive farming exacerbates the buildup of waste materials as well as the breakdown of baits and excrement, which eventually leads to water deterioration and an increase in aquaculture illnesses. Acute hepatopancreatic necrosis disease (AHPND), hepatopancreas necrosis syndrome (HPNS), and white feces syndrome (WFS) are three shrimp diseases that severely affect shrimp productivity worldwide (Dongwei Hou et al. 2018a; Huang et al. 2020, 2016; Lee et al. 2015). Specifically, during the growth of shrimp, ammonia nitrogen, or ammonia-N, readily builds up and poses a serious hazard to the life, physiological metabolism, and immune system of the cultured shrimp (Chang et al. 2015; Romano and Zeng 2013).

Prior research has demonstrated that the physical and chemical characteristics of pond water, such as its pH, temperature, salinity, dissolved oxygen content, ammonia, and so on, have a significant effect on the health of animals (Tovar et al., 2000; Visscher and Duerr 1991). According to Valencia-Castañeda et al. (2019), ammonia, nitrite, and nitrate are the most prevalent forms of inorganic nitrogen in ponds and crucial criteria for assessing water quality. According to a study conducted in industrial aquaculture ponds, ammonia-N concentrations varied significantly over the *L. vannamei* culture phase and were identified as one of the main factors affecting shrimp health (Liu et al. 2017). *L. vannamei* are more susceptible to infections when there is evidence of increased ammonia-N in the water, however the underlying mechanisms remain unclear (Hurvitz et al. 1997; Liu et al. 2017).

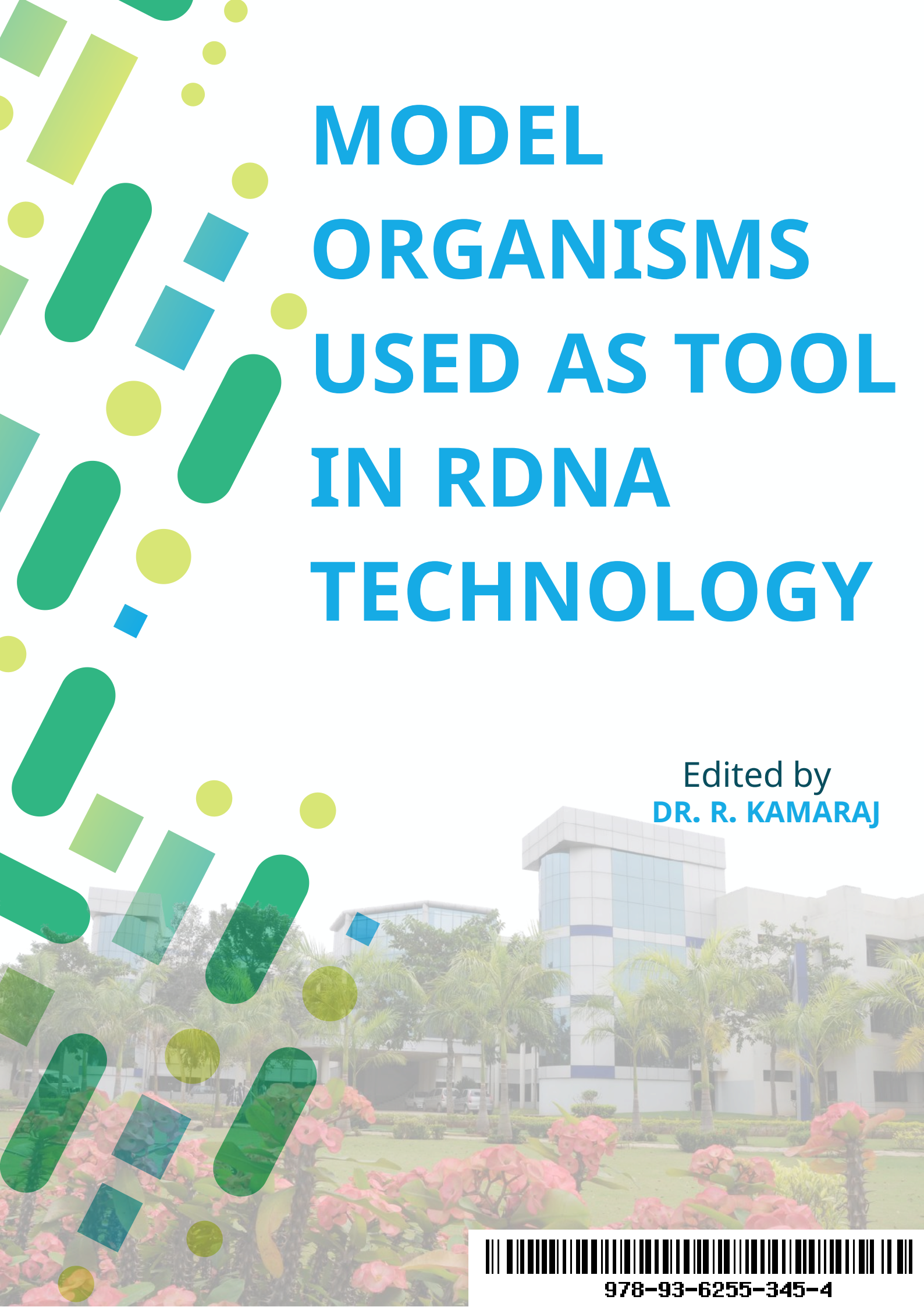

MODEL ORGANISMS USED AS TOOL IN RDNA TECHNOLOGY

Edited by
DR. R. KAMARAJ



978-93-6255-345-4

MODEL ORGANISM USED AS TOOL IN RDNA TECHNOLOGY

Copyright©2023 By Dr. R. Kamaraj

All rights reserved. No part of this book may be reproduced or transmitted in any form or by any means without written permission from the author.

ISSN: 978-93-6255-345-4

Publisher: Ponnaiyah Ramajayam Institute of Science and Technology (PRIST)

TABLE OF THE CONTENTS

| | |
|---|----|
| Chapter - 1 Model Organisms in rDNA Technology | 1 |
| Dr. R. Kamaraj | |
| Chapter - 2 Advantage of rDNA technology | 12 |
| Dr. C. Anitha | |
| Chapter - 3 rDNA Technology..... | 28 |
| Dr. T. Veeramani | |
| Chapter - 4 Organisms in rDNA Technology | 36 |
| Dr. S. Ramadevi | |
| Chapter - 5 Importance of Model Organisms..... | 48 |
| Dr. T. Veeramani | |
| Chapter - 6 Applications of rDNA Technology in Model Organisms | 57 |
| Dr. Arjunpandian | |
| Chapter - 7 Future Directions technology | 68 |
| Dr. J.Illamathi | |
| References | 81 |

Chapter - 1 Model Organisms in rDNA Technology

Dr. R. Kamaraj

Assistant professor, Department of Biotechnology,
Ponnaiyah Ramajayam Institute of Science
and Technology, Tamil Nadu, India.

Recombinant DNA (rDNA) technology has profoundly transformed molecular biology and genetics, enabling scientists to manipulate genetic material for various applications, including the development of vaccines and genetically modified crops. A critical component of this progress is the use of model organisms, which provide biological systems to explore the principles of rDNA technology. This essay highlights key model organisms in rDNA research, their advantages, and their contributions to the field.

Importance of Model Organisms

Model organisms are species that scientists study extensively to understand biological processes. They are chosen for several specific advantages:

- **Ease of Maintenance:** These organisms are typically simple to culture and maintain in laboratory environments.
- **Rapid Life Cycle:** Many model organisms have short generation times, allowing for quick experimental turnover.
- **Genetic Similarity:** Insights gained from these organisms can often be applied to more complex species, including humans.

Key Model Organisms in rDNA Research

1. **Escherichia coli (E. coli):**
 - **Rapid Growth:** E. coli can double in number approximately every 20 minutes, enabling rapid experimentation and large-scale cloning.
 - **Well-Characterized Genome:** The genome of E. coli has been extensively studied, and numerous genetic tools are available for manipulation.
 - **Cloning Vector:** E. coli serves as a host for plasmids—circular DNA molecules that can carry foreign DNA—facilitating the cloning and amplification of specific genes.
 - **Protein Production:** This bacterium can be engineered to produce a variety of proteins, including insulin and other therapeutic agents, making it invaluable in biotechnology.
 - In rDNA technology, E. coli has played a pivotal role in developing techniques like polymerase chain reaction (PCR), which amplifies DNA sequences for further study.

Chapter - 2 Advantage of rDNA technology

Dr. C. Anitha

Assistant professor, Department of Biotechnology,
Ponnaiyah Ramajayam Institute of Science
and Technology, Tamil Nadu, India.

Model organisms play a crucial role in rDNA technology, offering a range of benefits that facilitate research in genetics and molecular biology. Here's a summary of their advantages and some considerations regarding their use:

Advantages of Model Organisms

1. **Simplification of Complex Processes:** Model organisms help scientists deconstruct intricate biological systems into manageable parts, enhancing our understanding of fundamental biological processes.
2. **Ethical Considerations:** Utilizing simpler organisms mitigates ethical concerns associated with experimenting on higher animals or humans, enabling more extensive and humane research.
3. **Cost-Effectiveness:** Model organisms are often less expensive to maintain compared to larger or more complex organisms, making research more accessible to a wider range of scientists.
4. **High Throughput:** Many model organisms can be cultured in large numbers, allowing for high-throughput screening of genetic modifications and responses to drugs, expediting the research process.
5. **Translational Research:** Insights gained from model organisms often translate effectively to human biology, providing valuable implications for medical research and therapeutic development.

Contributions to Science

Model organisms, ranging from *E. coli* to *Mus musculus*, have been instrumental in exploring genetic manipulation, gene function, and complex biological processes. Their diverse systems enable scientists to investigate a variety of molecular biology principles.

Ongoing Importance

The contributions of these organisms have led to significant advancements in medicine, agriculture, and biotechnology, emphasizing their essential role in the ongoing exploration of genetic science. As technology evolves, model organisms will remain critical for unraveling the complexities of life and addressing global challenges in health and sustainability.

Chapter – 3 rDNA Technology

Dr. T. Veeramani

Assistant professor, Department of Biotechnology,
Ponnaiyah Ramajayam Institute of Science
and Technology, Tamil Nadu, India.

Introduction

Recombinant DNA (rDNA) technology has significantly enhanced our understanding of genetics and molecular biology, paving the way for revolutionary advancements in medicine, agriculture, and biotechnology. A crucial element of rDNA research is the use of model organisms – species that serve as biological stand-ins to explore complex biological processes. This essay examines several key model organisms in rDNA research, focusing on their unique characteristics, advantages, and contributions to science.

Characteristics of Model Organisms

Model organisms are selected for their specific traits that facilitate rigorous scientific investigation. Key advantages include:

- **Ease of Maintenance:** Many model organisms are simple to culture in laboratory settings, allowing for consistent and reproducible experiments.
- **Rapid Life Cycles:** Species with short generation times enable researchers to observe multiple generations in a brief period, accelerating studies of inheritance and evolution.
- **Genetic Manipulation:** The ability to easily modify their genomes allows scientists to investigate gene function and expression in a controlled environment.
- **Translational Relevance:** Findings from model organisms can often be extrapolated to more complex systems, including humans, making them invaluable for biomedical research.

Key Model Organisms in rDNA Research

1. **Escherichia coli (E. coli):**
 - **Rapid Growth:** E. coli can double approximately every 20 minutes, facilitating the rapid production of large quantities of DNA.
 - **Well-Characterized Genome:** With a fully sequenced genome and a wealth of genetic tools, E. coli is ideal for cloning and gene manipulation.
 - **Versatile Protein Production:** It is widely used to express recombinant proteins, playing a crucial role in the pharmaceutical industry for producing essential biopharmaceuticals like insulin and vaccines.
2. **Saccharomyces cerevisiae (Yeast):**
 - **Eukaryotic Features:** Yeast shares many fundamental biological processes with higher eukaryotes, including post-translational

Chapter - 4 Organisms in rDNA Technology

Dr. S. Ramadevi

Assistant professor, Department of Biotechnology,
Ponnaiyah Ramajayam Institute of Science
and Technology, Tamil Nadu, India.

Model Organisms in Recombinant DNA Technology

Recombinant DNA (rDNA) technology has significantly transformed molecular biology and genetics, enabling the manipulation of genetic material to produce new forms of life, develop vaccines, and create genetically modified crops. Central to these advancements is the use of model organisms, which serve as biological systems for studying the principles and applications of rDNA technology. This essay explores key model organisms utilized in rDNA research, highlighting their advantages and contributions to the field.

Definition of Model Organisms

Model organisms are species that are extensively studied to understand biological processes due to their specific advantages. These organisms are typically easy to maintain in the laboratory, have rapid life cycles, and possess genetic similarities to more complex organisms. Insights gained from studying these organisms can often be extrapolated to other species, including humans.

Key Model Organisms in rDNA Research

1. Escherichia coli (E. coli)

E. coli is arguably the most widely used model organism in molecular biology and rDNA technology. This bacterium is favored for several reasons:

- **Rapid Growth:** *E. coli* can double in number every 20 minutes, allowing for quick experiments and large-scale cloning.
- **Well-Characterized Genome:** Its genome has been extensively studied, and many tools are available for genetic manipulation, facilitating research and development.
- **Cloning Vector:** *E. coli* serves as a host for plasmids – circular DNA molecules that can carry foreign DNA – enabling the cloning and amplification of specific genes.
- **Protein Production:** *E. coli* can be engineered to produce proteins, such as insulin and other therapeutic agents, making it invaluable in biotechnology.

In rDNA technology, *E. coli* has been pivotal in developing techniques such as polymerase chain reaction (PCR) and creating genetically modified organisms (GMOs).

2. Saccharomyces cerevisiae (Baker's Yeast)

Saccharomyces cerevisiae, commonly known as baker's yeast, is another key model organism in rDNA research. As a eukaryotic organism, it allows

Chapter - 5 Importance of Model Organisms

Dr. T. Veeramani

Assistant professor, Department of Biotechnology,
Ponnaiyah Ramajayam Institute of Science
and Technology, Tamil Nadu, India.

Introduction

Model organisms are essential tools for scientists seeking to understand biological processes. These organisms possess specific traits that make them suitable for research, allowing for insights that can often be applied to more complex systems, including humans. Here are some key attributes that characterize effective model organisms:

1. **Genetic Similarity:** Many model organisms share genetic traits with humans or other species, facilitating the study of gene function and disease mechanisms. This genetic resemblance allows researchers to draw parallels and extrapolate findings to human biology.
2. **Ease of Cultivation:** These organisms are typically easy to maintain in laboratory settings, enabling large-scale experiments. Their straightforward care requirements allow researchers to conduct consistent and reproducible studies.
3. **Rapid Life Cycles:** Many model organisms, such as fruit flies, have short generation times, allowing researchers to observe multiple generations in a brief period. This rapid life cycle is advantageous for studying inheritance patterns and evolutionary processes.
4. **Well-Characterized Genomes:** Model organisms often have extensively studied genomes, providing a solid foundation for genetic manipulation and analysis. The availability of genomic data facilitates targeted experiments and the interpretation of results.

Example Model Organisms

1. *Escherichia coli* (*E. coli*)

E. coli is one of the most widely used model organisms in molecular biology and rDNA technology, celebrated for its unique advantages:

- **Rapid Growth:** *E. coli* can double in number approximately every 20 minutes, allowing researchers to obtain results quickly and in large quantities.
- **Plasmid Systems:** It is commonly used as a host for plasmids – small, circular DNA molecules that can carry foreign DNA for cloning and expression. This ability to utilize plasmids is crucial for many genetic engineering applications.
- **Genetic Tools:** A wide array of genetic tools and techniques are available for manipulating *E. coli*, including restriction enzymes, ligases, and various

Chapter - 6 Applications of rDNA Technology in Model Organisms

Dr. Arjunpandian

Assistant professor, Department of Biotechnology,
Ponnaiyah Ramajayam Institute of Science
and Technology, Tamil Nadu, India.

Introduction

Model organisms are vital for advancing our understanding of genetics, molecular biology, and biotechnology. They provide unique advantages that facilitate a wide range of research applications, from gene cloning to disease modeling. Below are some key applications of model organisms in rDNA technology.

1. Gene Cloning and Protein Production

- Using organisms like *E. coli* and *Saccharomyces cerevisiae*, researchers can clone specific genes and produce recombinant proteins for therapeutic use, such as insulin and monoclonal antibodies. These organisms serve as efficient platforms for gene expression and protein synthesis, making them indispensable in pharmaceutical development.

2. Gene Function Studies

- In model organisms such as *Drosophila melanogaster* (fruit flies) and *Caenorhabditis elegans* (*C. elegans*), rDNA technology facilitates the investigation of gene functions and regulatory mechanisms. This research sheds light on developmental processes and genetic diseases, enhancing our understanding of how genes influence organismal traits and health.

3. Disease Modeling

- Mice are widely used to model human diseases, enabling researchers to study the genetic basis of conditions like cancer, diabetes, and neurodegenerative disorders. Transgenic and knockout mice are particularly valuable for understanding disease progression, identifying potential treatments, and testing therapeutic interventions.

4. Functional Genomics

- High-throughput sequencing and gene editing technologies allow model organisms to be used in comprehensive studies of gene expression, regulation, and interaction networks. This research helps to elucidate the complex relationships between genes and their functions in various biological contexts.

5. Biotechnology and Synthetic Biology

- Model organisms play a crucial role in the production of biofuels, pharmaceuticals, and other bioproducts. Their utility in industrial applications showcases their importance in developing sustainable technologies and innovative solutions for global challenges.

Chapter - 7 Future Directions technology

Dr. J. Illamathi

Assistant professor, Department of Biotechnology,
Ponnaiyah Ramajayam Institute of Science
and Technology, Tamil Nadu, India.

Future Directions for Model Organisms in rDNA Technology

As recombinant DNA (rDNA) technology and genetic engineering techniques continue to evolve, the roles of model organisms are expected to expand significantly. Advanced tools like CRISPR-Cas9 and synthetic biology will empower researchers to explore new systems and enhance existing ones. This evolution will likely foster a more integrated understanding of biology and genetics across various organisms. Here are some potential future directions for the use of model organisms in rDNA technology:

1. Multiplex Gene Editing

Future studies may increasingly utilize advanced CRISPR systems that enable the simultaneous editing of multiple genes. This capability will allow researchers to investigate complex genetic interactions and pathways in organisms like *Drosophila* and *C. elegans*. By exploring multiple genes at once, scientists can gain deeper insights into the regulation of biological processes and the interconnectedness of genetic pathways.

2. Base Editing and Prime Editing

Emerging techniques such as base editing and prime editing offer enhanced precision in genetic modifications. These methods enable researchers to make specific changes to DNA sequences without introducing double-strand breaks, reducing the risk of unwanted mutations. This precision could be particularly valuable for modeling human diseases, allowing for more accurate simulations of genetic conditions and their treatments.

3. Plants and Agricultural Models

As the demand for sustainable agriculture grows, plants such as *Arabidopsis thaliana* and rice (*Oryza sativa*) are likely to be used more extensively in rDNA studies. Researchers will focus on enhancing crop traits such as yield, disease resistance, and stress tolerance, thereby addressing food security challenges. Genetic modifications in these plants could lead to innovative agricultural solutions that benefit both farmers and consumers.

4. Exploring Non-Model Organisms

Advances in genome sequencing technologies will facilitate the exploration of non-model organisms. For instance, species used in environmental research—such as certain fish and amphibians—can provide valuable insights into evolutionary processes and ecological interactions. Studying these organisms may reveal novel

TESTING OF MATERIALS

Edited by

P VIJAYAKUMAR



978-93-6255-910-4

Testing Of Materials

Copyright © 2022-2023 by P VIJAYAKUMAR

All rights reserved. No part of this book may be reproduced or transmitted in any form or by any means without written permission from the author.

ISBN: 978-93-6255-910-4

Publisher : PRIST Publications.

TABLE OF CONTENTS

| | |
|--|-----|
| Introduction | 10 |
| CHAPTER 1 Introduction to Materials Testing | 25 |
| N SIVAHARINADHAN | |
| CHAPTER 2 Selection of material | 62 |
| Dr.S.DHANUSKODI | |
| CHAPTER 3 Mechanical Testing | 112 |
| M SUDHAKAR | |
| CHAPTER 4 Creep and Fatigue test - Principles, Techniques | 196 |
| G.ARUNKUMAR | |
| CHAPTER 5 Non Destructive Testing | 282 |
| J.RAJESH | |
| CHAPTER 6 Thermography test - Principles, Techniques | 355 |
| P SARATH KUMAR | |
| CHAPTER 7 Material Characterization Testing | 482 |
| J.SELVAMANI | |
| CHAPTER 8 Electrical and Magnetic Techniques- | |

Principles 542

K PURUSHOTHAMAN

CHAPTER 9 Nano materials586

R.BASKARAN

CHAPTER 10 Spectroscopy and Plasma 652

Dr.V.YALINI

REFERENCES 787

CHAPTER 1

INTRODUCTION TO MATERIALS TESTING

N SIVAHARINADHAN

Assistant Professor, Department of Mechanical Engineering, Ponnaiyah Ramajayam Institute of Science and Technology, Tamil Nadu, India.

This chapter aims to familiarize students with the advanced Concept of Testing of Materials and introduces Introduction to Materials Testing.

Measurement of the characteristics and behavior of such substances as metals, ceramics, or plastics under various conditions. The data thus obtained can be used in specifying the suitability of materials for various applications .e.g., building or aircraft construction, machinery, or packaging. Here's an overview of each platform:

Introduction to Materials Testing Includes:

Materials testing breaks down into five major categories: mechanical testing; testing for thermal properties; testing for electrical properties; testing for resistance to corrosion, radiation, and biological deterioration; and nondestructive testing.

There are two main categories of material testing: field testing and lab testing. All tests are guided by ASTM standards. The following information is a summary of common field and lab tests in construction.

CHAPTER 2

SELECTION OF MATERIAL

Dr.S.DHANUSKODI

Associate Professor, Department of Mechanical Engineering, Ponnaiyah Ramajayam Institute of Science and Technology, Tamil Nadu, India.

This chapter aims to familiarize students with the advanced Concept of Testing of Materials and introduces Selection of material.

Material selection is an essential aspect of product design and development. An appropriate material should meet many basic criteria including efficient manufacturability, performance, reliability non-degradability and recyclability. Here's an overview of each platform:

Selection of material Includes:

- Step 1: Identify the design requirements. The design requirements include the following items.
- Step 2: Identify materials selection criteria.
- Step 3: Identify candidate materials.
- Step 4: Evaluate candidate materials.
- Step 5: Select materials.

Key features of Selection of material:

Many factors must be considered in materials selection, which are classified as structural, economic/business, manufacturing, durability, environmental impact, and specialist properties for unique applications.

CHAPTER 3**MECHANICAL TESTING****M SUDHAKAR**

Assistant Professor, Department of Mechanical Engineering, Ponnaiyah Ramajayam Institute of Science and Technology, Tamil Nadu, India.

This chapter aims to familiarize students with the advanced Concept of Testing of Materials and introduces Mechanical Testing.

Mechanical testing equipment covers devices used for adhesion, compression, drop (shock), tensile, vibration, and fatigue testing.

A standard specimen is subjected to a gradually increasing load (force) until failure occurs. The resultant load-displacement behavior is used to determine a stress–strain curve, from which a number of mechanical properties can be measured. Here's an overview of each platform:

Mechanical Testing Includes:

- Hardness Testing.
- Tensile Testing.
- Impact Testing.
- Fracture Toughness Testing.
- Creep Testing.
- Fatigue Testing.
- Non-Destructive Testing.

Key features of Mechanical Testing:

The tensile test increases a tensile load in one direction, usually until a fracture occurs. The load can be

CHAPTER 4

CREEP AND FATIGUE TEST - PRINCIPLES, TECHNIQUES

G.ARUNKUMAR

*Assistant Professor, Department of Mechanical
Engineering, Ponnaiyah Ramajayam Institute of
Science and Technology, Tamil Nadu, India.*

This chapter aims to familiarize students with the advanced Concept of Testing of Materials and introduces Creep and Fatigue Test - Principles, Techniques

Creep testing measures the gradual rate of deformation of a material under constant load and temperature conditions. Fatigue testing, on the other hand, involves subjecting a material or structure to cyclic loading.

Principle of creep

The specimen of material is held at an elevated and stabilized testing temperature and loaded by tensile force, while the strain is recorded in time. Here's an overview of each platform:

Creep and Fatigue Test Includes:

Creep-fatigue testing (strain-controlled fatigue with a hold time at the peak tensile strain) is performed in a laboratory setting to approximate the expected damage mode.

CHAPTER 5**NON DESTRUCTIVE TESTING****J.RAJESH**

Assistant Professor, Department of Mechanical Engineering, Ponnaiyah Ramajayam Institute of Science and Technology, Tamil Nadu, India.

This chapter aims to familiarize students with the advanced Concept of Testing of Materials and introduces Non Destructive Testing.

It refers to an array of inspection methods that allow inspectors to evaluate and collect data about a material, system, or component without permanently altering it.

Non-Destructive Testing (NDT) is a discipline grouping together processes and techniques to identify characteristic differences, welding defects, and discontinuities, all while avoiding any harm to the original part. Here's an overview of each platform:

Non Destructive Testing Includes:

The 8 Most Common NDT Methods

- Visual NDT (VT)
- Ultrasonic NDT (UT)
- Radiography NDT (RT)
- Eddy Current NDT (ET)
- Magnetic Particle NDT (MT)
- Acoustic Emission NDT (AE)
- Dye Penetrate NDT (PT)
- Leak Testing (LT)

CHAPTER 6

THERMOGRAPHY TEST - PRINCIPLES, TECHNIQUES

P SARATH KUMAR

Assistant Professor, Department of Mechanical Engineering, Ponnaiyah Ramajayam Institute of Science and Technology, Tamil Nadu, India.

This chapter aims to familiarize students with the advanced Concept of Testing of Materials and introduces Thermography test - Principles, Techniques.

Infrared testing Non-destructive Testing is based on the principle that every object emits infrared radiation (heat) proportional to its temperature. While this radiation remains invisible to the naked eye, thermal cameras can effectively capture and detect it.

Thermo graphic inspections, also known as thermograph testing or infrared thermographs, use the principles of infrared emissions to identify temperature variations on surfaces. These differences can indicate potential flaws in construction or signs of early damage that require addressing. Here's an overview of each platform:

Thermography test - Principles, Techniques Includes:

The principle of infrared thermographs is based on the physical phenomenon that any body of a temperature above absolute zero (-273.15 °C) emits electromagnetic radiation.

CHAPTER 7**MATERIAL CHARACTERIZATION TESTING****J.SELVAMANI**

Assistant Professor, Department of Mechanical Engineering, Ponnaiyah Ramajayam Institute of Science and Technology, Tamil Nadu, India.

This chapter aims to familiarize students with the advanced Concept of Testing of Materials and introduces Material Characterization Testing.

Material characterization involves a broad group of analytical procedures used to evaluate chemical and physical make-up of any materials. It is different from material testing in that it focuses on fundamental characteristics rather than applied or utility properties.

Characterization techniques are used to obtain information about the chemical, physical, mechanical, and electrical properties of materials, which are critical for understanding their behavior and developing new materials with specific properties. Here's an overview of each platform:

Material Characterization Testing Includes:

- Understanding the mechanical properties of the materials used.
- Assessing system integrity.
- Verifying the materials used throughout construction.
- Identifying potential areas of concern.

CHAPTER 8

ELECTRICAL AND MAGNETIC TECHNIQUES- PRINCIPLES

K PURUSHOTHAMAN

*Assistant Professor, Department of Mechanical
Engineering, Ponnaiyah Ramajayam Institute of
Science and Technology, Tamil Nadu, India.*

This chapter aims to familiarize students with the advanced Concept of Testing of Materials and introduces Material Characterization Testing.

Together, they form electromagnetism. A moving electric charge generates a magnetic field. A magnetic field induces electric charge movement, producing an electric current. In an electromagnetic wave, the electric field and magnetic field are perpendicular to one another.

When electric current passes through current carrying conductor or coil then a magnetic field is produced around it. The working of appliances like electric bell is based on this principle.

The basic principle behind electrical methods is the injection of current into the ground using a pair of electrodes. This current causes a potential difference in the ground which is measured by a separate pair of electrodes. Here's an overview of each platform:

CHAPTER 9

NANO MATERIALS

R.BASKARAN

Assistant Professor, Department of Mechanical Engineering, Ponnaiyah Ramajayam Institute of Science and Technology, Tamil Nadu, India.

This chapter aims to familiarize students with the advanced Concept of Testing of Materials and introduces Nano materials.

Nano material refers to the basic unit of the material in three dimensions, at least one dimension size in the range of 1–100 nm. Nano materials can be divided into four categories according to dimension: zero-dimensional, one-dimensional, two-dimensional, and three-dimensional nano materials.

A few of the many examples include nano crystals, which are composed of a quantum dot surrounded by semiconductor materials, nano-scale silver, dendrimers, which are repetitively branched molecules, and fullerenes, which are carbon molecules in the form of a hollow sphere, ellipsoid or tube. Here's an overview of each platform:

Nano materials Includes:

Types

- Nanoporous materials.
- Nanoparticles.
- Fullerenes.
- Metal-based nanoparticles.
- One-dimensional nanostructures.

CHAPTER 10**SPECTROSCOPY AND PLASMA****Dr.V.YALINI**

Associate Professor, Department of Mechanical Engineering, Ponnaiyah Ramajayam Institute of Science and Technology, Tamil Nadu, India.

This chapter aims to familiarize students with the advanced Concept of Testing of Materials and introduces Spectroscopy and Plasma.

The spectrum contains information about the plasma: i.e. it is the fingerprint of the plasma. This notion constitutes the basis of plasma diagnostics or using the observed spectrum to infer the characteristics of the plasma, e.g. its temperature, density, and particle transport property over space.

Plasma is generated by heating ordinary matter to high temperatures, and is comprised of ions, atoms, and charged particles. As there is high energy within plasma, the atoms and ions present are in excited electronic states. When these relax, light is emitted. Here's an overview of each platform:

Spectroscopy and Plasma Includes:

Spectroscopy is based on the interaction between light and matter. When the matter absorbs the light, it undergoes excitation and de-excitation, resulting in the production of a spectrum. When matter absorbs ultraviolet radiation, the electrons present in it undergo excitation.

COMPUTER AIDED DESIGN AND MANUFACTURING

Edited by
M SUDHAKAR



978-93-6255-057-6

COMPUTER AIDED DESIGN AND MANUFACTURING

Computer Aided Design and Manufacturing

Copyright © 2022-2023 by

M SUDHAKAR

All rights reserved. No part of this book may be reproduced or transmitted in any form or by any means without written permission from the author.

ISBN: 978-93-6255-057-6

Publisher: PRIST Publications.

COMPUTER AIDED DESIGN AND MANUFACTURING

TABLE OF CONTENTS

| | | |
|-------------------------|--|-----|
| | Introduction..... | 8 |
| CHAPTER NO 1 | Introduction to CAD | 10 |
| P SARATH KUMAR | | |
| CHAPTER NO 2 | Geometric Modeling | 36 |
| J RAJESH | | |
| CHAPTER NO 3 | CAD Standards | 64 |
| N.SIVAHARINATHAN | | |
| CHAPTER NO 4 | Fundamental Of CNC | 86 |
| P VIJAYAKUMAR | | |
| CHAPTER NO 5 | CNC Part Programming | 108 |
| R.TAMIZHSELVAN | | |
| CHAPTER NO 6 | Cellular Manufacturing | 135 |
| Dr V YALINI | | |
| CHAPTER NO 7 | Flexible Manufacturing System (Fms) | 164 |
| R.BASKARAN | | |
| CHAPTER NO 8 | Computer Numerical Control of Machine Tool | 192 |
| M.SUDHAHAR | | |
| CHAPTER NO 9 | System Devices | 215 |
| J.SELVAMANI | | |
| CHAPTER NO 10 | Manufacturing Support Functions | 241 |
| DHANUSHKODI | | |

COMPUTER AIDED DESIGN AND MANUFACTURING

CHAPTER 1

Introduction to CAD

P SARATH KUMAR

Assistant Professor, Department of Mechanical Engineering, Ponnaiyah Ramajayam Institute of Science and Technology, Tamil Nadu, India.

This chapter aims to familiarize students with the Fundamental of Introduction to CAD

CAD stands for Computer-Aided Design. It's a software tool that allows users to create precise drawings and models in a digital format. CAD can be used for everything from drafting floor plans to designing complex machinery.

2D CAD: Primarily used for drafting and creating flat, two-dimensional drawings. Examples include AutoCAD LT and Draft Sight.

3D CAD: Allows for the creation of three-dimensional models and simulations. Examples include Solid Works, CATIA, and Autodesk Fusion 360.

Drawing and Modeling Tools: For creating detailed plans and models.

Parametric Design: Allows for design changes to automatically update related elements.

Simulation: Tests how a design will perform under various conditions.

Rendering: Creates realistic images of the design for presentations.

Collaboration: Enables multiple users to work on the same design simultaneously.

COMPUTER AIDED DESIGN AND MANUFACTURING

CHAPTER 2

Geometric Modeling

J.RAJESH

Assistant Professor, Department of Mechanical Engineering, Ponnaiyah Ramajayam Institute of Science and Technology, Tamil Nadu, India.

This chapter aims to familiarize students with the Geometric Modeling

.CURVE REPRESENTATION

(1) Parametric equation x, y, z coordinates are related by a parametric variable (u or θ)

(2) Nonparametric equation x, y, z coordinates are related by a function

Example: Circle (2-D)

Parametric equation

$$x = R \cos \theta, \quad y = R \sin \theta \quad (0 \leq \theta \leq 2\pi)$$

Nonparametric equation

$$x^2 + y^2 - R^2 = 0 \quad (\text{Implicit nonparametric form})$$

$$y = \pm \sqrt{R^2 - x^2} \quad (\text{Explicit nonparametric form})$$

TYPES OF CURVES USED IN GEOMETRIC MODELLING

Hermite curves

Bezeir curves

B-spline curves

NURBS curves

COMPUTER AIDED DESIGN AND MANUFACTURING

CHAPTER 3

CAD Standards

N.SIVAHARINATHAN

Assistant Professor, Department of Mechanical Engineering, Ponnaiyah Ramajayam Institute of Science and Technology, Tamil Nadu, India.

This chapter aims to familiarize students with the CAD Standards

Schematically, the operation of these standards with application programs is depicted in Figure. Details of some of these standards are discussed in the following sections.

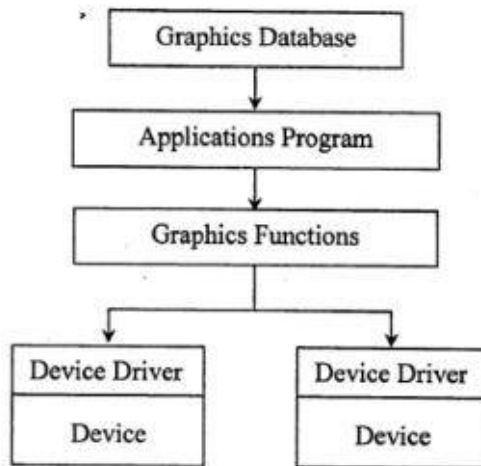

Various Standards in Graphics Programming

COMPUTER AIDED DESIGN AND MANUFACTURING

CHAPTER 4

Fundamental of CNC

P.VIJAYAKUMAR

Assistant Professor, Department of Mechanical Engineering, Ponnaiyah Ramajayam Institute of Science and Technology, Tamil Nadu, India.

This chapter aims to familiarize students with the Fundamental of CNC

CNC, or Computer Numerical Control, is a technology used to control machine tools via a computer. It automates the control of machining tools like drills, lathes, mills, and 3D printers. Here's a breakdown of the fundamental concepts of CNC:

Basic Principles

- **Numerical Control (NC):** The concept where machine tools are controlled via a set of commands or instructions. CNC is an advanced form where a computer manages these instructions.
- **G-code:** The programming language used to control CNC machines. It consists of a series of codes that dictate the movement and operations of the machine.

Components of a CNC System

- **Controller:** The computer system that reads and executes the G-code instructions. It converts the instructions into electrical signals to control the machine tool.
- **Machine Tool:** The actual equipment (e.g., mill, lathe, router) that performs the cutting, drilling, or shaping of materials based on the instructions received from the controller.
- **Drive System:** Includes motors and actuators that move the machine tool components (like the spindle or work table) in response to the controller's commands.
- **Feedback System:** Sensors and encoders that provide information on the machine's position and performance back to the controller, ensuring accurate and precise operations.

COMPUTER AIDED DESIGN AND MANUFACTURING

CHAPTER 5

CNC Part Programming

R.TAMIZHSELVAN

Assistant Professor, Department of Mechanical Engineering, Ponnaiyah Ramajayam Institute of Science and Technology, Tamil Nadu, India.

This chapter aims to familiarize students with the CNC Part Programming

CNC (Computer Numerical Control) part programming involves creating a set of instructions for a CNC machine to follow in order to produce a specific part or component. The programming defines how the machine should move, cut, and handle the material. Here's a basic overview of the process:

1. Understanding the Machine and Tooling

- **Machine Type:** Know whether you're working with a CNC mill, lathe, router, or another type of CNC machine.
- **Tooling:** Familiarize yourself with the tools available, like end mills, drills, and taps, and their specifications.

2. Part Design and Specifications

- **Blueprints:** Start with a detailed drawing or CAD (Computer-Aided Design) model of the part.
- **Dimensions:** Make sure you understand all dimensions, tolerances, and features.

3. Programming Languages

- **G-Code:** The most common programming language for CNC machines. It includes commands to control movement, speed, and tool changes.
- **M-Code:** Used for machine-specific functions, such as turning the spindle on/off or activating coolant.

COMPUTER AIDED DESIGN AND MANUFACTURING

CHAPTER 6

Cellular Manufacturing

V.YALINI

Professor, Department of Mechanical Engineering, Ponnaiyah Ramajayam Institute of Science and Technology, Tamil Nadu, India.

This chapter aims to familiarize students with the Cellular Manufacturing

Cellular manufacturing is a production strategy designed to improve efficiency and reduce waste by organizing workstations and equipment into cells that focus on producing specific families of products. Each cell is essentially a mini-factory, with everything needed to complete a set of tasks within that cell.

Here are some key aspects of cellular manufacturing:

Cell Design: Cells are arranged so that the flow of materials and products is streamlined. This layout minimizes transportation time and handling, which can reduce lead times and improve overall productivity.

Workstations and Equipment: Each cell contains all the necessary machines, tools, and workstations required to perform a series of operations. This can help reduce setup times and interruptions because workers have everything they need within arm's reach.

Product Families: Cells are often designed to handle a specific family of products that have similar manufacturing requirements. This allows for standardization of processes and reduces the complexity of production.

Employee Roles: In a cellular manufacturing setup, workers are typically cross-trained to handle multiple tasks within the cell. This flexibility can lead to higher job satisfaction and reduced labor costs.

COMPUTER AIDED DESIGN AND MANUFACTURING

CHAPTER 7

Flexible Manufacturing System (Fms)

R.BASKARAN

Assistant Professor, Department of Mechanical Engineering, Ponnaiyah Ramajayam Institute of Science and Technology, Tamil Nadu, India.

This chapter aims to familiarize students with the Flexible Manufacturing System (Fms)

A Flexible Manufacturing System (FMS) is a highly adaptable production setup designed to handle various types of products with minimal downtime and reconfiguration.

Key Features:

Modularity: FMS components, like machines and conveyors, can be reconfigured or expanded to accommodate different production needs.

Automation: The system often includes automated machinery, such as robotic arms, automated guided vehicles (AGVs), and computer-controlled equipment, which increases efficiency and consistency.

Programmability: FMS can be programmed to produce a range of products with different specifications. This flexibility is crucial for responding to changing market demands or custom orders.

Integration: It typically integrates with computer-aided design (CAD) and computer-aided manufacturing (CAM) systems to streamline the design-to-production process.

Real-time Monitoring: Advanced FMS setups include real-time monitoring and control systems to track production progress, equipment status, and quality.

COMPUTER AIDED DESIGN AND MANUFACTURING

CHAPTER 8

Computer Numerical Control of Machine Tool

M.SUDHAHAR

Professor, Department of Mechanical Engineering, Ponnaiyah Ramajayam Institute of Science and Technology, Tamil Nadu, India.

This chapter aims to familiarize students with the Computer Numerical Control of Machine Tool

Computer Numerical Control (CNC) of machine tools is a process that involves the use of computers to control machine tools. This technology is widely used in manufacturing and machining to achieve precise and consistent results. Here's a basic overview of how CNC works and its key components:

Basic Concept

- **Numerical Control (NC):** Originally, NC involved using punched tape or cards to control machine tools. Modern CNC is an advanced version where a computer controls the machine based on a program written in a specific code.
- **Computer Numerical Control (CNC):** CNC machines are controlled by computers using software programs. These programs specify the exact movements and operations of the machine tool, which allows for high precision and automation in manufacturing processes.

Key Components

- **CNC Controller:** The heart of the CNC system, this is a computer that interprets the program and directs the machine tool's movements. It converts the digital signals into electrical signals that drive the machine's motors.
- **Machine Tool:** The physical device that performs the machining tasks, such as a lathe, mill, or router. The machine tool executes movements and operations as directed by the CNC controller.

COMPUTER AIDED DESIGN AND MANUFACTURING

CHAPTER 9

System Devices

J.SELVAMANI

Professor, Department of Mechanical Engineering, Ponnaiyah Ramajayam Institute of Science and Technology, Tamil Nadu, India.

This chapter aims to familiarize students with the System Devices

System devices can cover a range of hardware components and peripherals, such as:

1. Input Devices: Keyboards, mice, scanners, and microphones.
2. Output Devices: Monitors, printers, speakers, and headphones.
3. Storage Devices: Hard drives, SSDs, USB drives, and optical discs.
4. Networking Devices: Routers, modems, network cards, and switches.
5. Peripheral Devices: External drives, webcams, and docking stations

COMPUTER AIDED DESIGN AND MANUFACTURING

CHAPTER 10

Manufacturing Support Functions

DHANUSHKODI

Professor, Department of Mechanical Engineering, Ponnaiyah Ramajayam Institute of Science and Technology, Tamil Nadu, India.

This chapter aims to familiarize students with Manufacturing Support Functions

Manufacturing support functions are critical components that help ensure smooth operations and high efficiency in the production process. They encompass a range of activities and service that aid in maintaining and improving the manufacturing process. Here are some key support functions in manufacturing:

1. Maintenance and Reliability Engineering:

- Preventive Maintenance: Scheduled activities to prevent equipment failures.
- Predictive Maintenance: Monitoring equipment condition to predict and address potential issues before they lead to breakdowns.
- Corrective Maintenance: Fixing equipment after a failure occurs.

2. Quality Control and Assurance:

- Inspection and Testing: Verifying that products meet quality standards through various tests and inspections.
- Process Improvement: Implementing systems like Six Sigma or Lean to enhance manufacturing processes and reduce defects.
- Compliance: Ensuring that products meet industry standards and regulatory requirements.

MECHATRONICS

MECHATRONICS

EDITED BY
R BASKARAN



978-93-6255-659-2

MECHATRONICS

Mechatronics

Copyright © 2023-2024 by R BASKARAN

All rights reserved. No part of this book may be reproduced or transmitted in any form or by any means without written permission from the author.

ISBN: 978-93-6255-659-2

Publisher: PRIST Publications.

MECHATRONICS

| | TABLE OF CONTENTS | |
|----------------------------|---|-----|
| | Introduction | 8 |
| CHAPTER NO 1 | Microprocessor | 11 |
| Dr. S V SRIDHAR | | |
| CHAPTER NO 2 | Programmable Peripheral Interface in mechatronics | 42 |
| R TAMIZH SELVAN | | |
| CHAPTER NO 3 | Programmable Logic Controller | 84 |
| P VIJAYAKUMAR | | |
| CHAPTER NO 4 | Actuators | 120 |
| R BASKARAN | | |
| CHAPTER NO 5 | Microcontroller | 175 |
| K PURUSHOTHAMAN | | |
| CHAPTER NO 6 | Peripheral Interfaces | 203 |
| M SUDHAKAR | | |
| CHAPTER NO 7 | Logic Controller | 237 |
| J RAJESH | | |
| CHAPTER NO 8 | Mechatronic System Design | 268 |
| Dr. S P KALAISELVAN | | |
| REFERENCES | | 300 |

MECHATRONICS

CHAPTER 1

Microprocessor

Dr. S V SRIDHAR

1. INTRODUCTION TO MICROPROCESSOR AND MICROCOMPUTER ARCHITECTURE:

A microprocessor is a programmable electronics chip that has computing and decision making capabilities similar to central processing unit of a computer. Any microprocessor-based systems having limited number of resources are called microcomputers. Nowadays, microprocessor can be seen in almost all types of electronics devices like mobile phones, printers, washing machines etc.

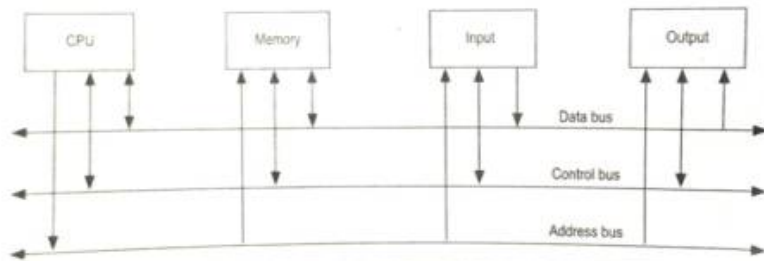

Fig.1 Microprocessor-based system

- **Address Bus:** It carries the address, which is a unique binary pattern used to identify a memory location or an I/O port. For example, an eight bit address bus has eight lines and thus it can address $2^8 = 256$ different locations. The locations in hexadecimal format can be written as 00H – FFH.
- **Data Bus:** The data bus is used to transfer data between memory and processor or between I/O device and processor. For example, an 8-bit processor will generally have an 8-bit data bus and a 16-bit processor will have 16-bit data bus.
- **Control Bus:** The control bus carry control signals, which consists of signals for selection of memory or I/O device from the given address, direction of data transfer and synchronization of data transfer in case of slow devices.

A typical microprocessor consists of arithmetic and logic unit (ALU) in association with control unit to process the instruction execution. Almost all the microprocessors are based on the principle of store-program concept. In store-program concept, programs or instructions

MECHATRONICS

CHAPTER 2

Programmable Peripheral Interface in mechatronics

R TAMIZH SELVAN

INTEL 8255: (Programmable Peripheral Interface)

The 8255A is a general purpose programmable I/O device designed for use with Intel microprocessors. It consists of three 8-bit bidirectional I/O ports (24 I/O lines) that can be configured to meet different system I/O needs. The three ports are PORT A, PORT B & PORT C. Port A contains one 8-bit output latch/buffer and one 8-bit input buffer. Port B is same as PORT A or PORT B. However, PORT C can be split into two parts PORT C lower (PC₀-PC₃) and PORT C upper (PC₇-PC₄) by the control word. The three ports are divided in two groups Group A (PORT A and upper PORT C) Group B (PORT B and lower PORT C). The two groups can be programmed in three different modes. In the first mode (mode 0), each group may be programmed in either input mode or output mode (PORT A, PORT B, PORT C lower, PORT C upper). In mode 1, the second's mode, each group may be programmed to have 8-lines of input or output (PORT A or PORT B) of the remaining 4-lines (PORT C lower or PORT C upper) 3-lines are used for hand shaking and interrupt control signals. The third mode of operation (mode 2) is a bidirectional bus mode which uses 8-line (PORT A only for a bidirectional bus and five lines (PORT C upper 4 lines and borrowing one from other group) for handshaking.

The 8255 is contained in a 40-pin package, whose pin out is shown below:

MECHATRONICS

CHAPTER 3

Programmable Logic Controller

P VIJAYAKUMAR

A programmable logic controller (PLC) or programmable controller is an industrial digital computer which has been ruggedized and adapted for the control of manufacturing processes, such as assembly lines, or robotic devices, or any activity that requires high reliability control and ease of programming and process fault diagnosis.

PLCs were first developed in the automobile manufacturing industry to provide flexible, ruggedized and easily programmable controllers to replace hard-wired relays, timers and sequencers. Since then, they have been widely adopted as high-reliability automation controllers suitable for harsh environments. A PLC is an example of a "hard" real-time system since output results must be produced in response to input conditions within a limited time, otherwise unintended operation will result

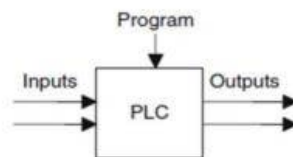

PLC architecture

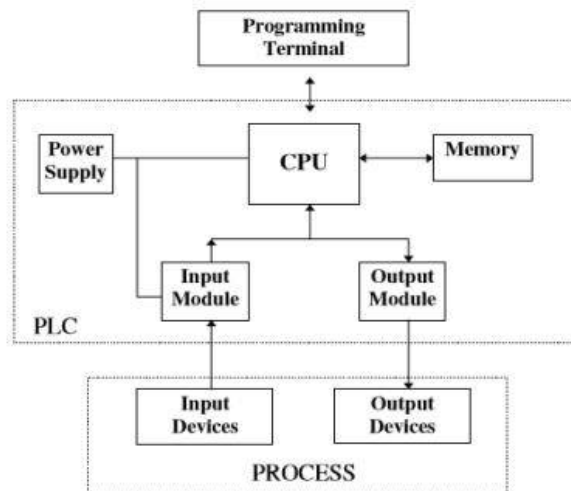

It consists of a central processing unit (CPU) containing the system microprocessor, memory, and input/output circuitry. The CPU controls and processes all the operations within the PLC. It is supplied with a clock that has a frequency of typically between 1 and 8 MHz. This frequency determines the operating speed of the PLC and provides the timing and

MECHATRONICS

CHAPTER 4

Actuators

R BASKARAN

In the previous section we have looked at some basic aspects of measurement systems. We have also noted the fundamental importance of measurement systems within mechatronic products and processes and how they influence the design of such systems. In a similar manner, drives and actuators play a primary role in mechatronic systems and their design and development within the integrative nature of a mechatronic approach, is critical for a successful design process.

As sensors and transducers produce the input to the mechatronic system, drives and actuators provide the output of the system, influencing the system itself and its environment as depicted in figure 5.1.

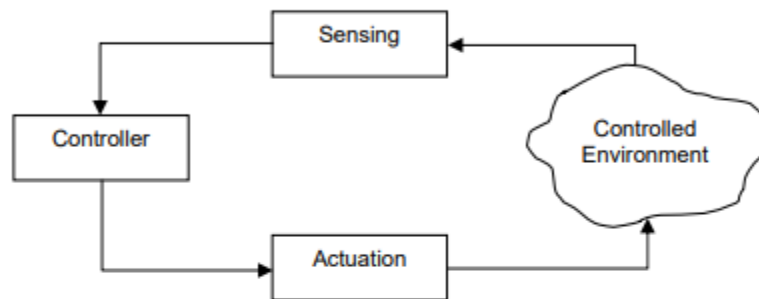

Figure 5.1 A Mechatronic System illustrating the interaction between controller and environment via sensing and actuation.

Typically actuators are considered as only energy conversion devices. For example an electrical motor converts electrical power to rotary motion. Similarly a hydraulic motor will convert hydraulic power (in the form of hydraulic fluid flow and pressure) into rotary motion. However, it is more common to take an inclusive view of actuators and consider the actuation systems instead. Here it is possible to distinguish two components of an actuation system;

1. **The Power Amplification and Modulation Stage**

This stage is concerned with converting the control signal (low power) into an appropriate signal that delivers the required input power to the energy conversion unit. In electrical drives, such an element will consist of a power electronic circuit, providing the appropriate high power switching to the electrical drive. On the other hand for a fluid power system such as a hydraulically powered drive, this stage will include appropriate valves (and hydraulic fluid supply), in order to convert the control signal to an appropriate hydraulic fluid flow and pressure to the hydraulic actuator.

2. **The Energy Conversion Stage**

This stage represents the physical actuator, i.e. the component that converts energy and produces work, acting on the controlled process or environment accordingly. In the case of an electrical drive, for example, one can be looking at an electrical motor, whereas for a hydraulic drive system, a hydraulic cylinder can be a typical example.

MECHATRONICS

CHAPTER 5

Microcontroller

K PURUSHOTHAMAN

1. INTRODUCTION TO MICROPROCESSOR AND MICROCOMPUTER ARCHITECTURE:

A microprocessor is a programmable electronics chip that has computing and decision making capabilities similar to central processing unit of a computer. Any microprocessor-based systems having limited number of resources are called microcomputers. Nowadays, microprocessor can be seen in almost all types of electronics devices like mobile phones, printers, washing machines etc.

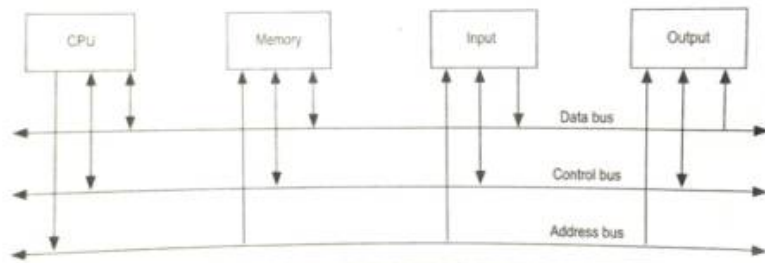

Fig.1 Microprocessor-based system

- **Address Bus:** It carries the address, which is a unique binary pattern used to identify a memory location or an I/O port. For example, an eight bit address bus has eight lines and thus it can address $2^8 = 256$ different locations. The locations in hexadecimal format can be written as 00H – FFH.
- **Data Bus:** The data bus is used to transfer data between memory and processor or between I/O device and processor. For example, an 8-bit processor will generally have an 8-bit data bus and a 16-bit processor will have 16-bit data bus.
- **Control Bus:** The control bus carry control signals, which consists of signals for selection of memory or I/O device from the given address, direction of data transfer and synchronization of data transfer in case of slow devices.

A typical microprocessor consists of arithmetic and logic unit (ALU) in association with control unit to process the instruction execution. Almost all the microprocessors are based on the principle of store-program concept. In store-program concept, programs or instructions

MECHATRONICS

CHAPTER 6

Peripheral Interfaces

M SUDHAKAR

INTEL 8255: (Programmable Peripheral Interface)

The 8255A is a general purpose programmable I/O device designed for use with Intel microprocessors. It consists of three 8-bit bidirectional I/O ports (24 I/O lines) that can be configured to meet different system I/O needs. The three ports are PORT A, PORT B & PORT C. Port A contains one 8-bit output latch/buffer and one 8-bit input buffer. Port B is same as PORT A or PORT B. However, PORT C can be split into two parts PORT C lower (PC₀-PC₃) and PORT C upper (PC₇-PC₄) by the control word. The three ports are divided in two groups Group A (PORT A and upper PORT C) Group B (PORT B and lower PORT C). The two groups can be programmed in three different modes. In the first mode (mode 0), each group may be programmed in either input mode or output mode (PORT A, PORT B, PORT C lower, PORT C upper). In mode 1, the second's mode, each group may be programmed to have 8-lines of input or output (PORT A or PORT B) of the remaining 4-lines (PORT C lower or PORT C upper) 3-lines are used for hand shaking and interrupt control signals. The third mode of operation (mode 2) is a bidirectional bus mode which uses 8-line (PORT A only for a bidirectional bus and five lines (PORT C upper 4 lines and borrowing one from other group) for handshaking.

The 8255 is contained in a 40-pin package, whose pin out is shown below:

MECHATRONICS

CHAPTER 7

Logic Controller

J RAJESH

A programmable logic controller (PLC) or programmable controller is an industrial digital computer which has been ruggedized and adapted for the control of manufacturing processes, such as assembly lines, or robotic devices, or any activity that requires high reliability control and ease of programming and process fault diagnosis.

PLCs were first developed in the automobile manufacturing industry to provide flexible, ruggedized and easily programmable controllers to replace hard-wired relays, timers and sequencers. Since then, they have been widely adopted as high-reliability automation controllers suitable for harsh environments. A PLC is an example of a "hard" real-time system since output results must be produced in response to input conditions within a limited time, otherwise unintended operation will result

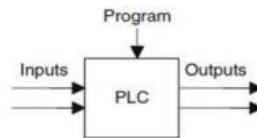

PLC architecture

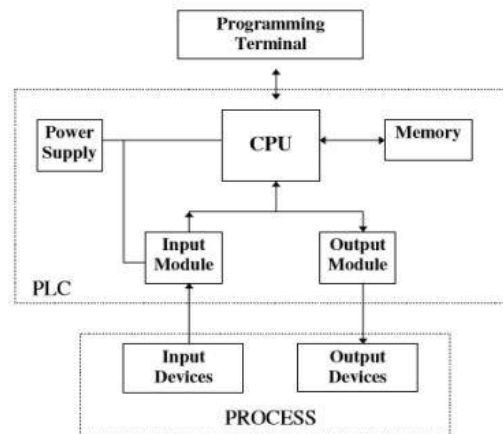

It consists of a central processing unit (CPU) containing the system microprocessor, memory, and input/output circuitry. The CPU controls and processes all the operations within the PLC. It is supplied with a clock that has a frequency of typically between 1 and 8 MHz. This frequency determines the operating speed of the PLC and provides the timing and

MECHATRONICS

CHAPTER 8

Mechatronic System Design

Dr. S P KALAISELVAN

In the previous section we have looked at some basic aspects of measurement systems. We have also noted the fundamental importance of measurement systems within mechatronic products and processes and how they influence the design of such systems. In a similar manner, drives and actuators play a primary role in mechatronic systems and their design and development within the integrative nature of a mechatronic approach, is critical for a successful design process.

As sensors and transducers produce the input to the mechatronic system, drives and actuators provide the output of the system, influencing the system itself and its environment as depicted in figure 5.1.

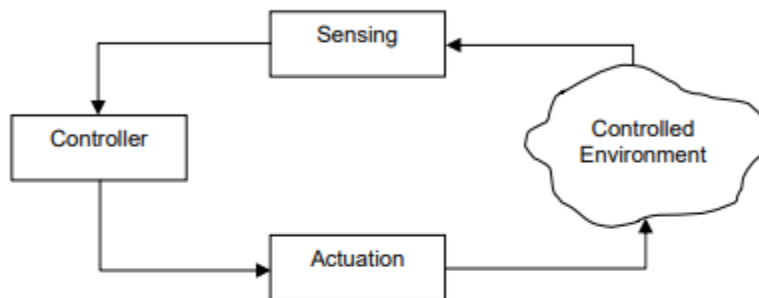

Figure 5.1 A Mechatronic System illustrating the interaction between controller and environment via sensing and actuation.

Typically actuators are considered as only energy conversion devices. For example an electrical motor converts electrical power to rotary motion. Similarly a hydraulic motor will convert hydraulic power (in the form of hydraulic fluid flow and pressure) into rotary motion. However, it is more common to take an inclusive view of actuators and consider the actuation systems instead. Here it is possible to distinguish two components of an actuation system;

1. ***The Power Amplification and Modulation Stage***

This stage is concerned with converting the control signal (low power) into an appropriate signal that delivers the required input power to the energy conversion unit. In electrical drives, such an element will consist of a power electronic circuit, providing the appropriate high power switching to the electrical drive. On the other hand for a fluid power system such as a hydraulically powered drive, this stage will include appropriate valves (and hydraulic fluid supply), in order to convert the control signal to an appropriate hydraulic fluid flow and pressure to the hydraulic actuator.

2. ***The Energy Conversion Stage***

This stage represents the physical actuator, i.e. the component that converts energy and produces work, acting on the controlled process or environment accordingly. In the case of an electrical drive, for example, one can be looking at an electrical motor, whereas for a hydraulic drive system, a hydraulic cylinder can be a typical example.

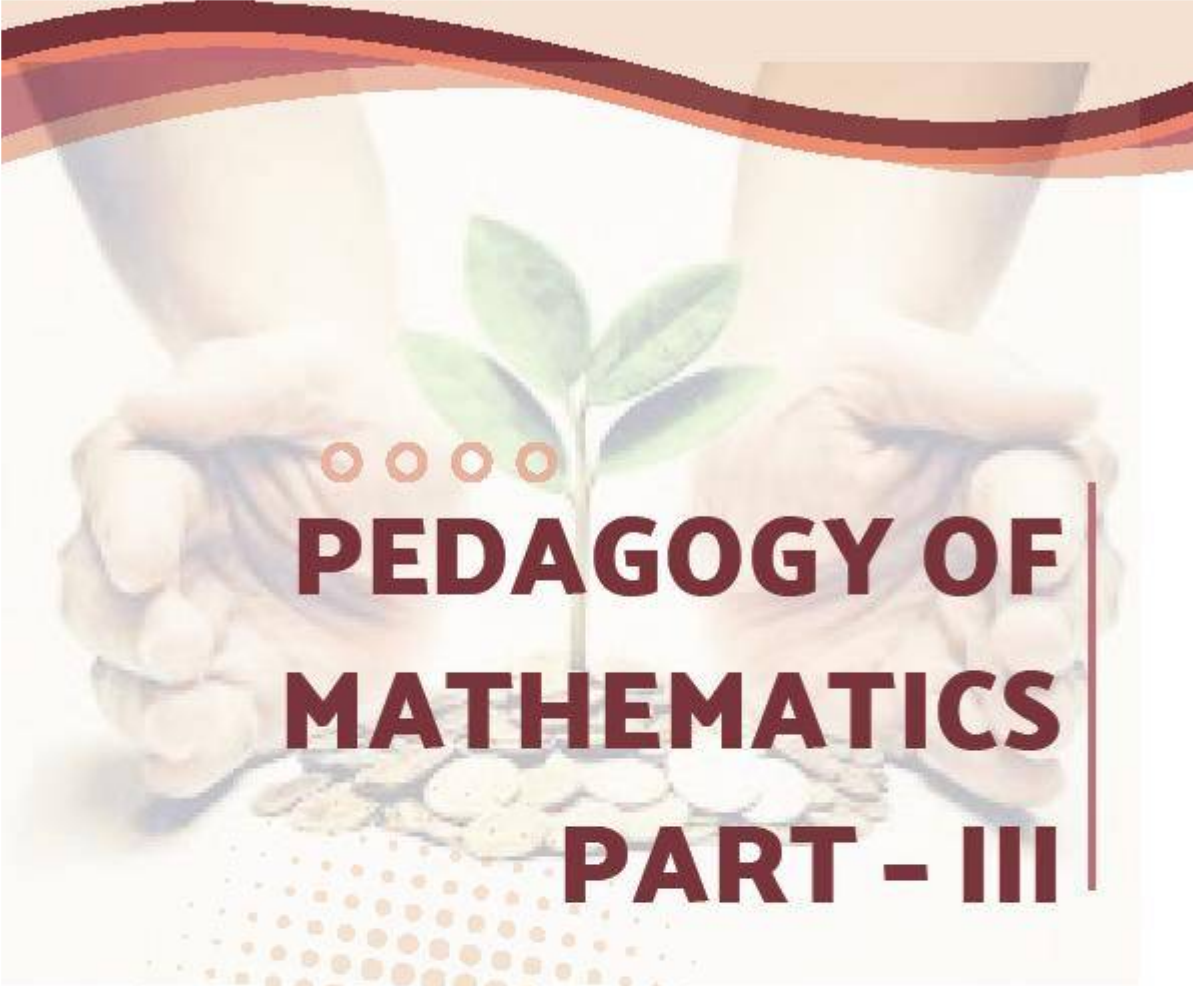

○○○○

PEDAGOGY OF MATHEMATICS PART - III



Edited by
**DR. M.ARON ANTONY
CHARLES**



978-93-6255-682-0

Pedagogy of Mathematics: Part - III

Copyright ©2023-2024 by Dr. M. Aron Antony Charles

All rights reserved. No part of this book may be reproduced or transmitted in any form or by any means without written permission from the author.

ISBN:978-93-6255-682-0

Publisher: Ponnaiyah Ramajayam Institute of Science and Technology (PRIST)

TABLE OF CONTENTS

| | |
|---|-----|
| Introduction | 3 |
| CHAPTER 1 Planning for Theory of Sets ... Prof. T. SELVARAJ | 16 |
| CHAPTER 2 Real Number System | 28 |
| DR. M. ARON ANTONY CHARLES | |
| CHAPTER 3 Algebra | 51 |
| Prof. T. SELVARAJ | |
| CHAPTER 4 Matrices | 68 |
| DR. M. ARON ANTONY CHARLES | |
| CHAPTER 5 Use of Lesson in School..... | 85 |
| Prof. T. SELVARAJ | |
| CHAPTER 6 Evaluation | 109 |
| DR. R. GUNASEKARAN | |
| CHAPTER 7 The Mathematics Teacher | 126 |
| DR. M. ARON ANTONY CHARLES | |
| CHAPTER 8 Planning for Instruction | 137 |
| Prof. T. SELVARAJ | |
| CHAPTER 9 Models of Teaching | 156 |
| Prof. R. VAISHNAVI | |
| CHAPTER 10 Equipment and Resources for Teaching Mathematics | 165 |
| Prof. T. SELVARAJ | |
| REFERENCES..... | 170 |

CHAPTER I
Planning for Theory of Sets
Prof. T. SELVARAJ
Assistant professor, School of Education,
PRIST Deemed to Be University, Thanjavur.

When planning a lesson on the theory of sets, it's helpful to structure the content and activities to engage students and facilitate understanding. Here's a suggested outline:

Lesson Objectives:

- Understand the basic concepts of sets, including definitions and notation.
- Identify different types of sets (e.g., finite, infinite, subsets, empty set).
- Learn operations with sets (union, intersection, difference).
- Apply set theory to solve problems.

Materials Needed:

- Whiteboard and markers
- Visual aids (e.g., Venn diagrams)
- Worksheets for practice
- Set of colored counters or objects for hands-on activities
- Online resources or interactive simulations

Lesson Outline:

1. **Introduction to Sets** (15 minutes)
 - Define a set and introduce notation (e.g., $\{1, 2, 3\}$).
 - Discuss types of sets (e.g., finite vs. infinite, subsets).
 - Provide examples and have students come up with their own sets.
2. **Set Operations** (20 minutes)
 - Explain operations: union ($A \cup B$), intersection ($A \cap B$), and difference ($A - B$).
 - Use Venn diagrams to visually represent these operations.
 - Conduct a guided practice with simple examples on the board.
3. **Hands-On Activity** (20 minutes)
 - Provide students with colored counters or objects to create their own sets.
 - Ask them to perform set operations with their counters and compare results with peers.
4. **Problem-Solving Practice** (15 minutes)
 - Distribute worksheets with problems involving set operations.
 - Include real-life applications (e.g., survey data, grouping).
5. **Class Discussion** (10 minutes)
 - Discuss the results of the worksheet problems.
 - Encourage students to explain their thought processes and any challenges they faced.
6. **Conclusion and Homework** (10 minutes)

CHAPTER 2 Real Number System

DR. M. ARON ANTONY CHARLES
Associate professor, School of Education,
PRIST Deemed to Be University, Thanjavur.

When planning a lesson on the real number system, it's important to cover its structure, properties, and applications. Here's a suggested outline:

Lesson Objectives:

- Understand the classification of real numbers (natural numbers, whole numbers, integers, rational numbers, irrational numbers).
- Learn the properties of real numbers (commutative, associative, distributive).
- Explore the number line and the relationship between different sets of numbers.

Materials Needed:

- Whiteboard and markers
- Number line visual aids
- Worksheets for practice
- Online resources or interactive tools (like number line simulations)

Lesson Outline:

1. **Introduction to Real Numbers** (15 minutes)
 - Define real numbers and their significance in mathematics.
 - Introduce the subsets of real numbers:
 - **Natural Numbers** (N)
 - **Whole Numbers** (W)
 - **Integers** (Z)
 - **Rational Numbers** (Q)
 - **Irrational Numbers** (e.g., $\sqrt{2}$, π)
2. **Number Line Representation** (15 minutes)
 - Show how to plot different types of numbers on a number line.
 - Discuss the density of rational numbers and the gaps for irrational numbers.
3. **Properties of Real Numbers** (20 minutes)
 - Explain key properties:
 - Commutative Property (e.g., $a + b = b + a$)
 - Associative Property (e.g., $(a + b) + c = a + (b + c)$)
 - Distributive Property (e.g., $a(b + c) = ab + ac$)
 - Provide examples and have students practice identifying these properties.
4. **Hands-On Activity** (20 minutes)
 - Create a large number line on the floor or board.
 - Have students come up and place different numbers (both rational and irrational) on the line.

CHAPTER 3

Algebra

Prof. T. SELVARAJ

Assistant professor, School of Education,
PRIST Deemed to Be University, Thanjavur.

When planning a lesson on algebra, it's important to cover key concepts, operations, and applications. Here's a suggested outline for a basic algebra lesson:

Lesson Objectives:

- Understand variables, constants, and expressions.
- Learn how to simplify and evaluate algebraic expressions.
- Solve basic linear equations and inequalities.

Materials Needed:

- Whiteboard and markers
- Algebra tiles or manipulatives
- Worksheets for practice
- Graphing calculators (optional)
- Online resources or interactive tools (like algebra simulation software)

Lesson Outline:

1. **Introduction to Algebra** (10 minutes)
 - Define algebra and its importance in mathematics.
 - Introduce variables (e.g., x , y) and constants (e.g., numbers).
 - Explain the difference between expressions and equations.
2. **Simplifying Expressions** (20 minutes)
 - Show how to combine like terms (e.g., $3x + 4x = 7x$).
 - Introduce the distributive property (e.g., $a(b + c) = ab + ac$).
 - Provide examples and guide students through practice problems.
3. **Evaluating Expressions** (15 minutes)
 - Teach how to substitute values into expressions (e.g., if $x = 3$, evaluate $2x + 5$).
 - Conduct practice exercises where students evaluate expressions for given values.
4. **Solving Linear Equations** (20 minutes)
 - Explain how to isolate the variable in simple equations (e.g., $2x + 3 = 7$).
 - Use algebra tiles or manipulatives for visual representation of solving equations.
 - Provide guided practice with a variety of equations.
5. **Introduction to Inequalities** (15 minutes)
 - Define inequalities and explain the symbols ($>$, $<$, \geq , \leq).
 - Show how to solve and graph simple inequalities (e.g., $x + 2 < 5$).
 - Discuss how the solution sets for inequalities differ from equations.
6. **Hands-On Activity** (15 minutes)

CHAPTER 4

Matrices

DR. M. ARON ANTONY CHARLES
Associate professor, School of Education,
PRIST Deemed to Be University, Thanjavur.

When planning a lesson on matrices, it's important to cover fundamental concepts, operations, and applications. Here's a suggested outline for an introductory lesson on matrices:

Lesson Objectives:

- Understand what a matrix is and how to represent data using matrices.
- Learn basic matrix operations: addition, subtraction, and multiplication.
- Explore applications of matrices in solving systems of equations.

Materials Needed:

- Whiteboard and markers
- Graph paper or grid paper
- Worksheets for practice
- Graphing calculators or computer software for matrix operations (optional)
- Online resources or interactive tools for visualizing matrices

Lesson Outline:

1. **Introduction to Matrices** (15 minutes)
 - Define a matrix and its components (rows, columns).
 - Explain matrix notation (e.g., $A = \begin{pmatrix} 1 & 2 \\ 3 & 4 \end{pmatrix}$).
 - Discuss different types of matrices (e.g., row matrix, column matrix, square matrix).
2. **Matrix Addition and Subtraction** (15 minutes)
 - Show how to add and subtract matrices of the same dimension.
 - Provide examples and have students practice with sample matrices.
3. **Matrix Multiplication** (20 minutes)
 - Explain the rules for matrix multiplication (e.g., dimensions must match).
 - Demonstrate how to multiply two matrices with step-by-step examples.
 - Provide practice problems for students to work on.
4. **Determinants and Inverses (Optional)** (20 minutes)
 - Introduce the concept of the determinant for 2x2 matrices.
 - Explain the conditions for a matrix to have an inverse and how to find it for 2x2 matrices.
 - Include a few examples and practice problems.
5. **Applications of Matrices** (15 minutes)

CHAPTER 5

Use of Lesson in School

Prof. T. SELVARAJ

**Assistant professor, School of Education,
PRIST Deemed to Be University, Thanjavur.**

Math lessons in school are essential for developing students' mathematical skills and understanding. Here are some key components and approaches typically found in math lessons:

1. **Objectives:** Clear learning objectives guide the lesson, specifying what students should know or be able to do by the end.
2. **Direct Instruction:** Teachers often introduce new concepts through direct instruction, using examples and demonstrations to explain mathematical principles.
3. **Guided Practice:** Students practice new skills with teacher support, allowing for immediate feedback and correction of misunderstandings.
4. **Independent Practice:** Assignments or activities where students work independently help reinforce their understanding and build confidence.
5. **Differentiation:** Lessons may include different levels of difficulty or varied tasks to meet the diverse needs of learners, ensuring all students are engaged.
6. **Hands-On Activities:** Incorporating manipulatives or technology can make abstract concepts more concrete and relatable.
7. **Real-World Applications:** Connecting math to real-life situations helps students see the relevance of what they're learning and increases motivation.
8. **Assessment and Feedback:** Regular assessments, both formative and summative, help monitor progress and guide future instruction.
9. **Collaboration:** Group work and discussions encourage peer learning and problem-solving.
10. **Reflection:** Ending a lesson with reflection allows students to think about what they learned and how they can apply it.

CHAPTER 6

Evaluation

DR. R. GUNASEKARAN
Assistant professor, School of Education,
PRIST Deemed to Be University, Thanjavur.

Evaluation in the context of education refers to the systematic process of assessing the effectiveness of teaching, learning, and educational strategies. It involves gathering and analyzing data to determine how well students are learning, how effectively instructional methods are working, and how educational objectives are being met. In the pedagogy of biological science, evaluation helps educators refine their teaching practices, assess student progress, and improve the curriculum.

Types of Evaluation in Education

1. Formative Evaluation

- **Definition:** Ongoing evaluations conducted during the teaching-learning process.
- **Purpose:** To monitor student learning and provide feedback that can be used to improve instruction and learning in real-time.
- **Examples:**
 - Classroom quizzes
 - Group discussions
 - Short feedback forms
 - Student reflections
- **Benefits:** Helps teachers adjust their teaching methods, address student misconceptions early, and guide students toward achieving learning goals.

2. Summative Evaluation

- **Definition:** Evaluation conducted at the end of a unit, course, or program to assess the overall effectiveness and achievement.
- **Purpose:** To evaluate student learning at the conclusion of an instructional period and to determine if the learning objectives were met.
- **Examples:**
 - Final exams
 - End-of-term projects
 - Standardized tests
 - Cumulative reports
- **Benefits:** Provides a comprehensive measure of student performance and curriculum effectiveness. Summative evaluations often inform grades and certifications.

3. Diagnostic Evaluation

- **Definition:** Pre-assessment conducted before instruction begins to understand students' prior knowledge and identify learning needs.
- **Purpose:** To identify strengths, weaknesses, and areas for improvement before the learning process starts.

CHAPTER 7

The Mathematics Teacher

DR. M. ARON ANTONY CHARLES
Associate professor, School of Education,
PRIST Deemed to Be University, Thanjavur.

"The Mathematics Teacher" is a well-respected journal published by the National Council of Teachers of Mathematics (NCTM). It focuses on innovative practices, research, and insights related to teaching mathematics at various educational levels.

1. **Research Articles:** Presenting findings from studies in math education.
2. **Teaching Strategies:** Practical tips and techniques for effective classroom instruction.
3. **Curriculum Development:** Discussions on designing and implementing math curricula.
4. **Technology Integration:** Exploring the role of technology in teaching and learning math.
5. **Professional Development:** Resources and ideas for teachers to enhance their skills.

This journal serves as a valuable resource for educators looking to improve their teaching methods and stay current with trends in mathematics education. Are you looking for specific topics or articles related to "The Mathematics Teacher"?

Key Responsibilities

1. **Curriculum Development**
 - Design and implement a curriculum that aligns with educational standards and industry trends, covering topics such as programming languages, algorithms, data structures, software development, and cybersecurity.
2. **Instructional Delivery**
 - Use a variety of teaching methods, including lectures, hands-on projects, and collaborative learning, to engage students with different learning styles.
 - Integrate technology into lessons, using tools such as IDEs, simulation software, and online resources to enhance learning.
3. **Assessment and Evaluation**
 - Create and administer assessments (quizzes, exams, projects) to evaluate student understanding and skills, providing constructive feedback to support improvement.
 - Use formative assessments to monitor progress and adjust instruction as needed.
4. **Facilitating Practical Experience**
 - Guide students through practical coding exercises, projects, and labs that allow them to apply theoretical concepts in real-world scenarios.
 - Encourage participation in coding competitions, hackathons, and collaborative projects to foster teamwork and problem-solving skills.
5. **Promoting Computational Thinking**
 - Teach students to approach problems methodically, breaking them down into smaller, manageable parts and using algorithms to devise solutions.

CHAPTER 8

Planning for Instruction

Prof. T. SELVARAJ

Assistant professor, School of Education,
PRIST Deemed to Be University, Thanjavur.

Planning for instruction is a vital component of effective teaching, as it involves organizing and designing lessons to meet learning objectives, address student needs, and ensure that the content is delivered effectively. In the context of biological science, instructional planning focuses on how to best teach scientific concepts, theories, and skills, ensuring that students can not only understand the material but also apply it to real-world scenarios.

Key Steps in Planning for Instruction

1. Define Learning Objectives

- **Purpose:** Clear learning objectives outline what students should know, understand, and be able to do by the end of the lesson or unit.
- **Examples:**
 - "Students will be able to explain the process of photosynthesis."
 - "Students will analyze the role of natural selection in evolution."
- **SMART Criteria:** Learning objectives should be **S**pecific, **M**easurable, **A**chievable, **R**elevant, and **T**ime-bound to ensure clarity and focus.

2. Identify and Align Curriculum Standards

- **Purpose:** Instruction must align with national, state, or local curriculum standards to ensure consistency and comprehensiveness.
- **Examples:** For biology, this may include standards related to genetics, ecosystems, evolution, and cell biology.
- **Benefits:** Ensures that instruction covers essential content and skills, helping students meet academic expectations.

3. Understand Student Needs and Context

- **Purpose:** Tailoring instruction to meet the diverse needs of learners.
- **Considerations:**
 - **Learning styles:** Some students may be visual learners, while others prefer hands-on activities or verbal instruction.
 - **Prior knowledge:** Assessing what students already know helps guide the depth of instruction.
 - **Diverse learning needs:** Differentiating instruction for students with special needs, language barriers, or advanced abilities is essential.
- **Examples:** Using models and diagrams for visual learners, or incorporating group activities for kinesthetic learners.

4. Select and Organize Content

- **Purpose:** Identify the key concepts, facts, and skills to be taught and decide the sequence in which they will be presented.
- **Examples:**
 - Teaching cellular biology before diving into genetics, as students need to understand cell structures and functions before learning about DNA.

CHAPTER 9
Models of Teaching
Prof. R. VAISHNAVI
Assistant professor, School of Education,
PRIST Deemed to Be University, Thanjavur.

Models of teaching refer to structured, systematic approaches to instruction that help guide the teaching process to achieve specific learning outcomes. These models are based on theories of learning and development and provide educators with frameworks for organizing and delivering content, fostering student engagement, and promoting the effective acquisition of knowledge and skills. Each model emphasizes different aspects of learning and teaching, and the choice of model depends on the subject matter, learning objectives, and the needs of the students.

Here are some of the most widely recognized models of teaching:

1. The Direct Instruction Model

- **Definition:** A teacher-centered approach that emphasizes clear, structured, and explicit teaching of content or skills.
- **Key Features:**
 - Focus on mastery of content through systematic instruction.
 - The teacher leads the lesson by providing information, modeling, and giving guided practice.
 - Frequent feedback and correction are given to ensure understanding.
 - Lesson phases: Introduction, Presentation, Guided Practice, Independent Practice, and Closure.
- **Advantages:**
 - Highly effective for teaching foundational skills, especially in areas like math, reading, or basic biology concepts.
 - Structured and efficient, which makes it ideal for covering large amounts of content.
- **Disadvantages:**
 - Less emphasis on critical thinking and creativity.
 - Limits student autonomy and may not engage all learners.

Example in Biology: Teaching the structure of the cell by explaining and modeling the parts, providing guided practice through labeling exercises, and then assigning independent activities like cell diagram creation.

2. The Inquiry-Based Learning Model

- **Definition:** A student-centered approach that encourages students to ask questions, investigate problems, and discover answers through exploration.
- **Key Features:**
 - Students are active participants in the learning process, conducting experiments, investigations, or research.

CHAPTER 10

Equipment and Resources for Teaching Mathematics

Prof. T. SELVARAJ

Assistant professor, School of Education,
PRIST Deemed to Be University, Thanjavur.

When teaching mathematics, having the right equipment and resources can make a significant difference in student engagement and understanding. Here's a list of useful tools and resources:

Equipment

1. **Whiteboards/Chalkboards:** Great for interactive teaching and problem-solving.
2. **Graphing Calculators:** Useful for higher-level math, especially calculus and statistics.
3. **Manipulatives:** Tools like blocks, counters, or geometric shapes help in visualizing concepts.
4. **Rulers and Protractors:** Essential for geometry lessons.
5. **Math Software:** Programs like GeoGebra, Desmos, or other math apps for graphing and simulations.
6. **Projector/Smartboard:** For displaying lessons, videos, and interactive content.

Resources

1. **Textbooks:** Choose textbooks that align with your curriculum and learning objectives.
2. **Online Platforms:** Websites like Khan Academy, IXL, or Mathway provide extra practice and explanations.
3. **Worksheets and Printables:** Resources from sites like Teachers Pay Teachers or educational blogs can offer additional practice.
4. **Math Games:** Incorporate games to make learning fun, such as Sudoku, logic puzzles, or online math games.
5. **Videos and Tutorials:** Use educational YouTube channels for visual explanations of complex topics.

Community and Collaboration

1. **Professional Development:** Attend workshops or webinars focused on math education strategies.
2. **Math Clubs:** Encourage students to join or form math clubs to foster a collaborative learning environment.
3. **Peer Teaching:** Pair students to help each other, reinforcing their understanding.

Assessment Tools

1. **Quizzes and Tests:** Regular assessments to gauge understanding.



PEDAGOGY OF ENGLISH PART – III

Edited by
T.SUBHASHINI



978-93-6255-385-8

Pedagogy of English: Part - III

Copyright ©2023-2024 by Prof. T. Subhashini

All rights reserved. No part of this book may be reproduced or transmitted in any form or by any means without written permission from the author.

ISBN: 978-93-6255-305-8

Publisher: Ponnaiyah Ramajayam Institute of Science and Technology (PRIST)

TABLE OF CONTENTS

| | |
|--|-----|
| Introduction | 3 |
| CHAPTER 1 Tenses-Classification types and Uses | 16 |
| Prof. T. SUBHASHINI | |
| CHAPTER 2 English Language and Its Nature..... | 28 |
| DR. T. S. PARVATHY | |
| CHAPTER 3 Aims and Objectives of Teaching English..... | 51 |
| Prof T. SELVARAJ | |
| CHAPTER 4 Language skills | 68 |
| DR. R. GUNASEKARAN | |
| CHAPTER 5 Methods and Approaches of Teaching English | 85 |
| Prof T. SELVARAJ | |
| CHAPTER 6 Evaluation | 109 |
| DR. R. GUNASEKARAN | |
| CHAPTER 7 The English Teacher | 126 |
| Prof. T. SUBHASHINI | |
| CHAPTER 8 Planning for Instruction | 137 |
| Prof. T. SELVARAJ | |
| CHAPTER 9 Models of Teaching | 156 |
| Prof. R. VAISHNAVI | |
| CHAPTER 10 Equipment and Resources for Teaching English..... | 165 |
| Prof. T. SUBHASHINI | |
| REFERENCES..... | 170 |

CHAPTER I

Tenses-Classification types and Uses

Prof. T. SUBHASHINI

Assistant Professor, School of Education, PRIST University, Thanjavur

Tenses in English grammar are categorized into three main types: **Past**, **Present**, and **Future**. Each of these types is further divided into four aspects: **Simple**, **Continuous (Progressive)**, **Perfect**, and **Perfect Continuous**. Here's a detailed classification and explanation of their uses:

1. Present Tense

- **Simple Present:**
 - **Structure:** Subject + base verb (add **-s/-es** with he/she/it).
 - **Uses:**
 - Habitual actions (e.g., "He **runs** every morning.")
 - Universal truths (e.g., "The Earth **revolves** around the Sun.")
 - Scheduled events (e.g., "The train **leaves** at 5 PM.")
 - Instructions or directions (e.g., "**Turn** left at the next corner.")
- **Present Continuous:**
 - **Structure:** Subject + is/am/are + verb + ing.
 - **Uses:**
 - Actions happening right now (e.g., "She **is reading** a book.")
 - Temporary actions (e.g., "I **am living** in New York for a year.")
 - Future plans (e.g., "We **are meeting** tomorrow.")
- **Present Perfect:**
 - **Structure:** Subject + has/have + past participle.
 - **Uses:**
 - Actions completed at an unspecified time (e.g., "I **have visited** France.")
 - Actions that started in the past and continue to the present (e.g., "She **has lived** here for five years.")
 - Recent actions with present relevance (e.g., "I **have just finished** my homework.")
- **Present Perfect Continuous:**
 - **Structure:** Subject + has/have + been + verb + ing.
 - **Uses:**
 - Actions that began in the past and are still continuing (e.g., "They **have been playing** football for two hours.")
 - Emphasis on duration of an action (e.g., "I **have been studying** all day.")

Past Tense

- **Simple Past:**
 - **Structure:** Subject + past form of the verb.
 - **Uses:**
 - Completed actions in the past (e.g., "She **visited** the museum yesterday.")

CHAPTER 2 English Language and Its Nature

DR. T. S. PARVATHY

Assistant Professor, School of Education, PRIST Deemed to be University, Thanjavur

The English language is a rich and complex system of communication with several key characteristics that define its nature:

1. Global Language

- **Widespread Use:** English is spoken as a first language in countries like the United States, the United Kingdom, Canada, Australia, and New Zealand, and as a second language in many others. It serves as a lingua franca in international business, diplomacy, and science.

2. Dynamic and Evolving

- **Adaptability:** English constantly evolves, adopting new words and phrases from other languages and cultures. This adaptability reflects changes in society, technology, and communication.

3. Diverse Dialects and Varieties

- **Regional Variations:** There are numerous dialects of English, including British English, American English, Australian English, and Indian English, each with unique vocabulary, pronunciation, and grammar rules.
- **Creole and Pidgin Forms:** In many regions, English has mixed with local languages, resulting in unique forms such as Caribbean English Creole or Singapore English.

4. Rich Vocabulary

- **Lexical Borrowing:** English has a vast vocabulary that includes words from Latin, Greek, French, German, and many other languages. This makes it particularly flexible in expression.
- **Synonyms and Nuances:** The language has many synonyms, allowing for nuanced expression and variation in tone and style.

5. Complex Grammar

- **Flexibility in Syntax:** English has a relatively free word order compared to some languages, allowing for various sentence structures while still maintaining clarity.
- **Tense and Aspect:** The use of tenses and aspects to indicate time and continuity is intricate, allowing for detailed expressions of actions and states.

6. Phonetic and Phonological Variability

CHAPTER 3 Aims and Objectives of Teaching English

Prof T. SELVARAJ

Assistant Professor, School of Education, PRIST Deemed to be University, Thanjavur

Teaching English effectively involves clear aims and objectives that guide instruction and assessment. Here are some key aims and objectives:

Aims of Teaching English

1. **Communication Skills:**
 - Enable students to communicate effectively in both spoken and written forms.
2. **Cultural Understanding:**
 - Foster an appreciation of diverse cultures and perspectives associated with the English language.
3. **Critical Thinking:**
 - Develop analytical and critical thinking skills through engagement with texts and language.
4. **Language Proficiency:**
 - Achieve proficiency in the four key language skills: listening, speaking, reading, and writing.
5. **Lifelong Learning:**
 - Encourage an interest in continuous language learning and self-improvement.

Objectives of Teaching English

1. **Listening Skills:**
 - Students will be able to understand spoken English in various contexts, including conversations, lectures, and media.
2. **Speaking Skills:**
 - Students will be able to express themselves clearly and confidently in spoken English, participating in discussions and presentations.
3. **Reading Skills:**
 - Students will develop the ability to read and comprehend a range of texts, including literature, non-fiction, and informational material.
4. **Writing Skills:**
 - Students will be able to produce coherent, well-structured written texts for different purposes (e.g., essays, reports, creative writing).
5. **Grammar and Vocabulary:**
 - Students will acquire a solid understanding of English grammar rules and a rich vocabulary to enhance their language use.
6. **Critical Analysis:**
 - Students will learn to analyze and interpret various texts, recognizing themes, perspectives, and literary techniques.

CHAPTER 4 Language skills

Dr. R. GUNASEKARAN

Assistant Professor, School of Education, PRIST Deemed to be University, Thanjavur.

Language skills are typically categorized into four primary areas: **listening**, **speaking**, **reading**, and **writing**. Each skill plays a vital role in effective communication and language proficiency. Here's a breakdown of each:

1. Listening Skills

- **Understanding Spoken Language:** The ability to comprehend and interpret spoken words in various contexts, including conversations, lectures, and media.
- **Active Listening:** Engaging with the speaker, showing attentiveness through non-verbal cues, and responding appropriately.
- **Listening Comprehension:** Analyzing and summarizing information from audio sources, such as podcasts or speeches.

2. Speaking Skills

- **Oral Communication:** The ability to express thoughts and ideas clearly and effectively in spoken form.
- **Pronunciation and Intonation:** Using correct sounds and speech patterns to enhance clarity and understanding.
- **Conversational Skills:** Engaging in dialogue, asking questions, and maintaining discussions, including taking turns and using appropriate body language.
- **Presentation Skills:** The ability to organize and deliver information to an audience confidently and coherently.

3. Reading Skills

- **Decoding:** The ability to recognize words and understand their meanings in context.
- **Comprehension:** Understanding and interpreting written texts, including identifying main ideas, supporting details, and themes.
- **Critical Reading:** Analyzing texts to evaluate arguments, biases, and perspectives, and drawing inferences.
- **Reading for Different Purposes:** Adapting reading strategies based on the context (e.g., skimming for general understanding, scanning for specific information).

4. Writing Skills

- **Written Communication:** The ability to express ideas clearly and effectively in written form.
- **Grammar and Mechanics:** Using correct grammar, punctuation, and spelling to enhance clarity and professionalism.

CHAPTER 5 Methods and Approaches of Teaching English

Prof T. SELVARAJ

Assistant Professor, School of Education, PRIST University, Thanjavur

There are several methods and approaches to teaching English, each with its own philosophy, strategies, and techniques. Here's an overview of some of the most commonly used methods:

1. Grammar-Translation Method

- **Focus:** Emphasizes the learning of grammatical rules and vocabulary through translation of texts.
- **Techniques:** Students translate sentences between their native language and English, memorize vocabulary, and learn grammatical structures.
- **Strengths:** Useful for reading and writing; good for understanding formal language structures.
- **Limitations:** Limited focus on speaking and listening skills; often considered less engaging.

2. Direct Method

- **Focus:** Promotes immersion in the target language, emphasizing oral skills and vocabulary without using the students' native language.
- **Techniques:** Uses real-life situations, demonstrations, and visual aids to teach vocabulary and grammar in context.
- **Strengths:** Enhances speaking and listening skills; fosters intuitive learning.
- **Limitations:** May be challenging for beginners without sufficient vocabulary.

3. Audiolingual Method

- **Focus:** Based on behaviorist theories, it emphasizes habit formation through repetition and drills.
- **Techniques:** Uses dialogues, pattern drills, and reinforcement to teach language structures.
- **Strengths:** Effective for pronunciation and listening skills; helps in building foundational language patterns.
- **Limitations:** Limited emphasis on reading and writing; may lack context and communicative practice.

4. Communicative Language Teaching (CLT)

- **Focus:** Aims to develop communicative competence, enabling students to use language in real-life situations.
- **Techniques:** Engages students in meaningful communication through role-plays, discussions,

CHAPTER 6

Evaluation

DR. R. GUNASEKARAN

Assistant Professor, School of Education, PRIST Deemed to be University, Thanjavur

Evaluation in the context of education refers to the systematic process of assessing the effectiveness of teaching, learning, and educational strategies. It involves gathering and analyzing data to determine how well students are learning, how effectively instructional methods are working, and how educational objectives are being met. In the pedagogy of biological science, evaluation helps educators refine their teaching practices, assess student progress, and improve the curriculum.

Types of Evaluation in Education

1. Formative Evaluation

- **Definition:** Ongoing evaluations conducted during the teaching-learning process.
- **Purpose:** To monitor student learning and provide feedback that can be used to improve instruction and learning in real-time.
- **Examples:**
 - Classroom quizzes
 - Group discussions
 - Short feedback forms
 - Student reflections
- **Benefits:** Helps teachers adjust their teaching methods, address student misconceptions early, and guide students toward achieving learning goals.

2. Summative Evaluation

- **Definition:** Evaluation conducted at the end of a unit, course, or program to assess the overall effectiveness and achievement.
- **Purpose:** To evaluate student learning at the conclusion of an instructional period and to determine if the learning objectives were met.
- **Examples:**
 - Final exams
 - End-of-term projects
 - Standardized tests
 - Cumulative reports
- **Benefits:** Provides a comprehensive measure of student performance and curriculum effectiveness. Summative evaluations often inform grades and certifications.

3. Diagnostic Evaluation

- **Definition:** Pre-assessment conducted before instruction begins to understand students' prior knowledge and identify learning needs.
- **Purpose:** To identify strengths, weaknesses, and areas for improvement before the learning process starts.

CHAPTER 7

The English Teacher

Prof. T. SUBHASHINI

Assistant Professor, School of Education, PRIST University, Thanjavur

The English Teacher refers to a professional whose primary role is to teach English language and literature to students. They play a pivotal role in developing students' reading, writing, speaking, and listening skills, as well as fostering an appreciation for literature and critical thinking.

Below are key aspects of the role of an English teacher:

1. Role and Responsibilities

- **Teaching Language Skills:** English teachers focus on teaching the core language skills: reading, writing, listening, and speaking. They also teach grammar, vocabulary, and pronunciation.
- **Literature Instruction:** They introduce students to various literary genres, including poetry, drama, short stories, and novels, fostering analytical thinking and interpretive skills.
- **Assessment:** Regularly assess student progress through essays, tests, projects, and presentations to evaluate understanding and improvement.
- **Encouraging Critical Thinking:** English teachers encourage students to analyze texts, understand themes, question assumptions, and form independent opinions about what they read or hear.
- **Cultural Awareness:** Through literature and language, English teachers expose students to diverse cultures, perspectives, and ideas, helping them understand global contexts.
- **Classroom Management:** Like all educators, English teachers must manage student behavior, promote a positive classroom environment, and maintain discipline while ensuring that learning objectives are met.
- **Curriculum Design:** Some English teachers may be involved in designing or modifying the English curriculum to better meet student needs or align with new standards.

2. Qualities of an Effective English Teacher

- **Strong Communication Skills:** Clear and articulate communication is crucial for teaching language effectively.
- **Passion for Literature and Language:** A love for reading and an appreciation for language help to inspire students to engage with the subject.
- **Patience and Empathy:** Teaching language can be challenging, especially with students who struggle with reading or writing. A good English teacher must be patient and empathetic to different learning paces.
- **Creativity:** English teachers often have to find creative ways to present material, especially when dealing with complex literary concepts or abstract language skills.

CHAPTER 8

Planning for Instruction

Prof. T. SELVARAJ

Assistant Professor, School of Education, PRIST Deemed to be University, Thanjavur

Planning for instruction is a vital component of effective teaching, as it involves organizing and designing lessons to meet learning objectives, address student needs, and ensure that the content is delivered effectively. In the context of biological science, instructional planning focuses on how to best teach scientific concepts, theories, and skills, ensuring that students can not only understand the material but also apply it to real-world scenarios.

Key Steps in Planning for Instruction

1. **Define Learning Objectives**
 - **Purpose:** Clear learning objectives outline what students should know, understand, and be able to do by the end of the lesson or unit.
 - **Examples:**
 - "Students will be able to explain the process of photosynthesis."
 - "Students will analyze the role of natural selection in evolution."
 - **SMART Criteria:** Learning objectives should be **S**pecific, **M**easurable, **A**chievable, **R**elevant, and **T**ime-bound to ensure clarity and focus.
2. **Identify and Align Curriculum Standards**
 - **Purpose:** Instruction must align with national, state, or local curriculum standards to ensure consistency and comprehensiveness.
 - **Examples:** For biology, this may include standards related to genetics, ecosystems, evolution, and cell biology.
 - **Benefits:** Ensures that instruction covers essential content and skills, helping students meet academic expectations.
3. **Understand Student Needs and Context**
 - **Purpose:** Tailoring instruction to meet the diverse needs of learners.
 - **Considerations:**
 - **Learning styles:** Some students may be visual learners, while others prefer hands-on activities or verbal instruction.
 - **Prior knowledge:** Assessing what students already know helps guide the depth of instruction.
 - **Diverse learning needs:** Differentiating instruction for students with special needs, language barriers, or advanced abilities is essential.
 - **Examples:** Using models and diagrams for visual learners, or incorporating group activities for kinesthetic learners.
4. **Select and Organize Content**
 - **Purpose:** Identify the key concepts, facts, and skills to be taught and decide the sequence in which they will be presented.
 - **Examples:**
 - Teaching cellular biology before diving into genetics, as students need to understand cell structures and functions before learning about DNA.

CHAPTER 9

Models of Teaching

Prof. R. VAISHNAVI

Assistant Professor, School of Education, PRIST University, Thanjavur

Models of teaching refer to structured, systematic approaches to instruction that help guide the teaching process to achieve specific learning outcomes. These models are based on theories of learning and development and provide educators with frameworks for organizing and delivering content, fostering student engagement, and promoting the effective acquisition of knowledge and skills. Each model emphasizes different aspects of learning and teaching, and the choice of model depends on the subject matter, learning objectives, and the needs of the students.

Here are some of the most widely recognized models of teaching:

1. The Direct Instruction Model

- **Definition:** A teacher-centered approach that emphasizes clear, structured, and explicit teaching of content or skills.
- **Key Features:**
 - Focus on mastery of content through systematic instruction.
 - The teacher leads the lesson by providing information, modeling, and giving guided practice.
 - Frequent feedback and correction are given to ensure understanding.
 - Lesson phases: Introduction, Presentation, Guided Practice, Independent Practice, and Closure.
- **Advantages:**
 - Highly effective for teaching foundational skills, especially in areas like math, reading, or basic biology concepts.
 - Structured and efficient, which makes it ideal for covering large amounts of content.
- **Disadvantages:**
 - Less emphasis on critical thinking and creativity.
 - Limits student autonomy and may not engage all learners.

Example in Biology: Teaching the structure of the cell by explaining and modeling the parts, providing guided practice through labeling exercises, and then assigning independent activities like cell diagram creation.

2. The Inquiry-Based Learning Model

- **Definition:** A student-centered approach that encourages students to ask questions, investigate problems, and discover answers through exploration.
- **Key Features:**
 - Students are active participants in the learning process, conducting experiments, investigations, or research. Emphasis on higher-order thinking skills such as analysis, synthesis, and evaluation.

CHAPTER 10

Equipment and Resources for Teaching English

Prof. T. SUBHASHINI

Assistant Professor, School of Education, PRIST Deemed to be University, Thanjavur.

When teaching English, having the right equipment and resources can enhance the learning experience and make lessons more engaging. Here's a list of useful equipment and resources:

1. Classroom Equipment

- **Whiteboard/Blackboard:** For writing, illustrating concepts, and engaging students in interactive lessons.
- **Projector and Screen:** To display presentations, videos, and online resources for a more dynamic learning environment.
- **Audio Equipment:** Speakers and microphones for listening activities, especially in larger classrooms.
- **Smartboards:** Interactive boards that combine traditional whiteboard functionality with digital technology for engaging lessons.

2. Digital Tools

- **Computers/Laptops/Tablets:** For accessing online resources, interactive activities, and language learning software.
- **Language Learning Apps:** Tools like Duolingo, Rosetta Stone, or Quizlet for independent practice and vocabulary building.
- **Online Collaboration Tools:** Platforms like Google Docs, Padlet, or Microsoft Teams for group projects and discussions.

3. Teaching Resources

- **Textbooks:** Structured materials that cover grammar, vocabulary, and skills in a systematic way.
- **Workbooks:** Supplementary materials for practice, exercises, and assessments.
- **Flashcards:** Useful for vocabulary practice, grammar rules, and language games.
- **Visual Aids:** Posters, charts, and infographics that illustrate language concepts and vocabulary.

4. Multimedia Resources

- **Videos and Films:** Educational videos, documentaries, and films that expose students to various accents and contexts.
- **Podcasts and Audio Resources:** Listening exercises and discussions on various topics to improve listening skills.
- **Interactive Websites:** Websites like BBC Learning English or ESL Lab that offer a variety of exercises and lessons.

KNOWLEDGE AND CURRICULUM

EDITED BY

R.VAISHNAVI



978-93-6255-121-4

Knowledge and Curriculum

Copyright ©2023-2024 by Prof. R. Vaishnavi

All rights reserved. No part of this book may be reproduced or transmitted in any form or by any means without written permission from the author.

ISBN:978-93-6255-121-4

Publisher: Ponnaiyah Ramajayam Institute of Science and Technology (PRIST)

TABLE OF CONTENTS

| | |
|--|-----|
| Introduction | 5 |
| CHAPTER 1 Knowledge and Curriculum..... | 17 |
| DR. R. GUNASEKARAN | |
| CHAPTER 2 Meaning, Nature and Principles of Curriculum..... | 26 |
| Prof. T. SUBHASHINI | |
| CHAPTER 3 Curriculum Design and Organization of Knowledge..... | 49 |
| Prof. R. VAISHNAVI | |
| CHAPTER 4 Curriculum Development and Implementation..... | 68 |
| Prof. T. SELVARAJ | |
| CHAPTER 5 Curriculum Evaluation and Change..... | 85 |
| Prof. R. VAISHNAVI | |
| CHAPTER 6 Knowledge Dimension..... | 107 |
| Prof. T. SUBHASHINI | |
| CHAPTER 7 Principles of Curriculum | 125 |
| DR. R. GUNASEKARAN | |
| CHAPTER 8 Sources of Curriculum Design..... | 137 |
| Prof. T. SELVARAJ | |
| CHAPTER 9 Models of Curriculum | 151 |
| Prof. R. VAISHNAVI | |
| CHAPTER 10 Curriculum change and Innovation..... | 163 |
| Prof. T. SUBHASHINI | |
| REFERENCES..... | 171 |

CHAPTER 1
Knowledge and Curriculum
DR. R. GUNASEKARAN
Assistant professor, School of Education,
PRIST Deemed to Be University, Thanjavur.

The relationship between knowledge and curriculum is central to education, as the curriculum serves as a structured plan for delivering knowledge and skills to students. Here are some key considerations:

1. **Definition of Curriculum:** The curriculum encompasses the content, skills, and experiences that students are expected to learn. It includes the subjects taught, the materials used, the instructional methods, and the assessment strategies.
2. **Types of Knowledge:**
 - **Declarative Knowledge:** This includes facts, concepts, and information that students need to know (e.g., historical dates, scientific principles).
 - **Procedural Knowledge:** This refers to skills and processes (e.g., solving math problems, conducting experiments).
 - **Conditional Knowledge:** Understanding when and why to apply certain knowledge or skills (e.g., choosing the right method for a specific problem).
3. **Curriculum Design:** Curriculum can be designed in various ways:
 - **Subject-Centered:** Focuses on specific subjects or disciplines, organizing content according to topics and subtopics.
 - **Student-Centered:** Prioritizes the interests and needs of students, allowing for more flexibility and exploration.
 - **Integrated Curriculum:** Combines multiple subjects or themes, encouraging connections between different areas of knowledge.
4. **Standards and Frameworks:** Many curricula are guided by national or state standards that outline what students should know and be able to do at each grade level. These standards help ensure consistency and quality across educational settings.
5. **Relevance and Context:** A meaningful curriculum should relate to students' lives and experiences, making learning relevant. This can involve using real-world examples and applications to enhance understanding.
6. **Cultural Responsiveness:** Recognizing and incorporating students' cultural backgrounds and perspectives in the curriculum enriches the learning experience and promotes inclusivity.
7. **Assessment and Evaluation:** Effective assessment strategies are essential for measuring student learning and ensuring that the curriculum is meeting its objectives. This includes formative assessments (ongoing checks for understanding) and summative assessments (evaluating overall learning at the end of a unit).
8. **Curricular Adaptation:** Flexibility in curriculum design allows educators to adapt lessons to meet the diverse needs of learners. This includes differentiating instruction and providing various pathways for students to demonstrate their understanding.
9. **Technology Integration:** Incorporating technology into the curriculum can enhance engagement and provide new ways for students to access and interact with knowledge.

CHAPTER 2

Meaning, Nature and Principles of Curriculum

Prof. T. SUBHASHINI

Assistant professor, School of Education,
PRIST Deemed to Be University, Thanjavur.

Understanding the meaning, nature, and principles of curriculum is essential for effective educational planning and implementation. Here's an overview:

Meaning of Curriculum

Curriculum refers to the structured set of learning experiences, knowledge, skills, and attitudes that educational institutions aim to provide to students. It includes:

- **Content:** The subject matter and topics covered in a course or program.
- **Instructional Strategies:** The methods and approaches used to teach the content.
- **Assessment:** The ways in which student learning is evaluated.
- **Learning Outcomes:** The goals and objectives that students are expected to achieve by the end of a course or program.

Nature of Curriculum

The nature of curriculum can be characterized by several key aspects:

1. **Dynamic:** Curriculum is not static; it evolves based on societal changes, educational research, and the needs of learners.
2. **Comprehensive:** It encompasses a wide range of knowledge and skills, including academic, vocational, and social-emotional learning.
3. **Contextual:** Curriculum is influenced by cultural, social, and economic contexts, which shape the learning environment and experiences.
4. **Integrative:** It seeks to make connections between different subjects and areas of knowledge, promoting interdisciplinary learning.
5. **Holistic:** Curriculum aims to develop the whole child, addressing cognitive, emotional, social, and physical aspects of learning.

Principles of Curriculum

Several foundational principles guide the development and implementation of an effective curriculum:

1. **Relevance:** The curriculum should be relevant to students' lives, interests, and future needs. It should connect learning to real-world applications.
2. **Flexibility:** A good curriculum allows for adaptation and personalization to meet the diverse needs, abilities, and learning styles of students.

CHAPTER 3
Curriculum Design and Organization of Knowledge
Prof. R. VAISHNAVI
Assistant professor, School of Education,
PRIST Deemed to Be University, Thanjavur.

Curriculum design and the organization of knowledge are critical aspects of educational planning that influence how content is delivered and understood by students. Here's an overview of both concepts:

Curriculum Design

Curriculum design refers to the process of developing and structuring the curriculum to achieve educational goals. Key components include:

1. **Goals and Objectives:** Clearly defined goals outline what the curriculum aims to achieve. Objectives provide specific, measurable outcomes that guide instruction and assessment.
2. **Content Selection:** Choosing relevant and meaningful content is essential. This involves deciding what knowledge, skills, and attitudes will be included based on the needs of students, societal demands, and educational standards.
3. **Learning Activities:** Designing engaging and diverse learning activities that promote active participation helps students apply knowledge in practical ways. Activities may include discussions, projects, hands-on experiences, and collaborative work.
4. **Instructional Strategies:** Selecting appropriate teaching methods that align with learning goals is crucial. This may involve direct instruction, inquiry-based learning, differentiated instruction, and more.
5. **Assessment and Evaluation:** Developing methods to assess student understanding and progress is essential. This can include formative assessments (ongoing checks for understanding) and summative assessments (evaluating overall learning).
6. **Feedback Mechanisms:** Establishing ways to provide constructive feedback to students helps guide their learning and improvement.

Organization of Knowledge

The organization of knowledge within the curriculum is about structuring content in a way that facilitates understanding and retention. Key aspects include:

1. **Scope and Sequence:** Defining the breadth (scope) of the content and the order (sequence) in which it will be taught is crucial. This ensures a logical progression of ideas and skills.
2. **Hierarchical Structure:** Organizing knowledge in a hierarchical manner helps students build on prior knowledge. Concepts can be arranged from simple to complex, allowing for scaffolding of learning.

CHAPTER 4
Curriculum Development and Implementation
Prof. T. SELVARAJ
Assistant professor, School of Education,
PRIST Deemed to Be University, Thanjavur.

Curriculum development and implementation are essential processes in education that involve creating a structured plan for teaching and learning, as well as executing that plan effectively. Here's an overview of both stages:

Curriculum Development

1. **Needs Assessment:** This initial step involves identifying the needs of students, teachers, and the community. Surveys, interviews, and data analysis can help determine gaps in knowledge and skills.
2. **Setting Goals and Objectives:** Establishing clear, measurable goals and specific objectives provides direction for what the curriculum aims to achieve. These should align with educational standards and the needs identified in the assessment.
3. **Content Selection:** Choosing relevant and appropriate content is crucial. This includes selecting topics, themes, and materials that are aligned with the goals and resonate with students' interests and backgrounds.
4. **Designing Learning Activities:** Creating engaging, varied learning activities that encourage active participation and critical thinking is important. This may include projects, discussions, hands-on activities, and technology integration.
5. **Assessment Planning:** Developing assessment strategies to evaluate student understanding and progress is essential. This includes formative assessments (ongoing evaluations) and summative assessments (final evaluations).
6. **Feedback Mechanisms:** Establishing ways to provide feedback to students and teachers can guide improvements and enhance the learning experience.
7. **Professional Development:** Providing training and support for educators involved in implementing the curriculum ensures they are equipped with the necessary skills and knowledge.

Curriculum Implementation

1. **Training and Support:** Educators should receive adequate training on the new curriculum, including instructional strategies and assessment methods. Ongoing support is essential for successful implementation.
2. **Resource Allocation:** Ensuring that necessary resources (e.g., textbooks, technology, materials) are available and accessible is crucial for effective implementation.
3. **Adaptation and Flexibility:** Teachers may need to adapt the curriculum based on classroom dynamics, student needs, and emerging situations. Flexibility in implementation allows for responsiveness to challenges.
4. **Monitoring and Evaluation:** Continuously monitoring the implementation process helps identify areas for improvement. Collecting data on student performance and engagement can provide insights into the curriculum's effectiveness.

CHAPTER 5
Curriculum Evaluation and Change
Prof. R. VAISHNAVI
Assistant professor, School of Education,
PRIST Deemed to Be University, Thanjavur.

Curriculum evaluation and change are critical processes that ensure educational programs remain relevant, effective, and aligned with the needs of students and society. Here's an overview of both concepts:

Curriculum Evaluation

1. **Purpose of Evaluation:** The primary goal of curriculum evaluation is to assess the effectiveness of the curriculum in achieving its objectives, improving student learning outcomes, and informing future revisions.
2. **Types of Evaluation:**
 - **Formative Evaluation:** Conducted during the implementation phase to provide ongoing feedback. It helps identify areas for improvement and allows for adjustments in real-time.
 - **Summative Evaluation:** Conducted after the curriculum has been implemented to assess its overall effectiveness. It typically involves measuring student performance, engagement, and satisfaction.
3. **Evaluation Methods:**
 - **Quantitative Methods:** Use numerical data to measure outcomes (e.g., standardized test scores, attendance rates). Surveys and questionnaires can also collect quantitative feedback.
 - **Qualitative Methods:** Gather descriptive data through interviews, focus groups, and observations. This approach provides insights into the experiences and perceptions of students and teachers.
4. **Stakeholder Involvement:** Engaging various stakeholders—teachers, students, parents, and administrators—in the evaluation process enhances the comprehensiveness and relevance of the findings.
5. **Data Analysis:** Analyzing collected data helps identify trends, strengths, and areas needing improvement. It's important to interpret results in the context of the curriculum goals and objectives.
6. **Reporting Findings:** Sharing evaluation findings with stakeholders is crucial for transparency and collaborative decision-making. Reports should highlight successes, challenges, and recommendations for improvement.

Curriculum Change

1. **Need for Change:** Curriculum change may be prompted by various factors, including shifts in educational standards, societal needs, advancements in technology, and feedback from evaluations.
2. **Types of Change:**

CHAPTER 6

Knowledge Dimension Prof. T. SUBHASHINI

The knowledge dimension is a framework that categorizes different types of knowledge and how they can be applied in educational contexts. This framework is often associated with educational taxonomies, such as Bloom's Taxonomy, and can help educators design curriculum and assessments that target various levels of understanding. Here's an overview of the key components of the knowledge dimension:

1. Types of Knowledge

- **Declarative Knowledge:** Knowledge of facts and information that can be stated or declared. This includes concepts, principles, and theories (e.g., knowing historical dates or scientific laws).
- **Procedural Knowledge:** Knowledge of processes and skills that involve the application of methods or techniques. This includes knowing how to perform tasks (e.g., solving mathematical equations or conducting experiments).
- **Conditional Knowledge:** Knowledge of when and why to apply certain skills or concepts. This involves understanding the context in which specific knowledge is relevant and can be used effectively (e.g., knowing which problem-solving strategy to apply in different situations).

2. Cognitive Levels

The knowledge dimension can also be categorized into cognitive levels that reflect the complexity of understanding:

- **Remembering:** Recalling facts and basic concepts (e.g., defining terms, listing information).
- **Understanding:** Explaining ideas or concepts (e.g., summarizing a text, interpreting data).
- **Applying:** Using knowledge in new situations (e.g., solving problems, implementing strategies).
- **Analyzing:** Breaking down information into parts and understanding its structure (e.g., comparing and contrasting ideas, organizing data).
- **Evaluating:** Making judgments based on criteria and standards (e.g., assessing arguments, critiquing sources).
- **Creating:** Putting elements together to form a new whole (e.g., designing a project, developing a hypothesis).

3. Application in Education

CHAPTER 7

Principles of Curriculum

DR. R. GUNASEKARAN

**Assistant professor, School of Education,
PRIST Deemed to Be University, Thanjavur.**

The principles of curriculum guide the development, implementation, and evaluation of educational programs. Here are some key principles that help ensure the curriculum is effective, relevant, and responsive to students' needs:

1. Relevance

- The curriculum should connect to students' lives, interests, and experiences. It should prepare them for real-world challenges and opportunities, making learning meaningful.

2. Flexibility

- A good curriculum should be adaptable to the diverse needs of students. It should allow for modifications based on individual learning styles, abilities, and interests.

3. Inclusivity

- The curriculum must be inclusive, accommodating all students regardless of their backgrounds, abilities, and learning differences. It should promote equity and respect for diversity.

4. Integration

- Curriculum should promote connections between subjects and disciplines, encouraging interdisciplinary learning. This helps students see relationships among different areas of knowledge.

5. Engagement

- Active participation and engagement in the learning process are essential. The curriculum should incorporate varied teaching methods and activities that stimulate students' curiosity and motivation.

6. Continuous Improvement

- The curriculum should be regularly evaluated and updated based on feedback from stakeholders, including students, teachers, and the community. This ensures it remains relevant and effective.

7. Developmentally Appropriate

CHAPTER 8

Sources of Curriculum Design

Prof. T. SELVARAJ

Assistant professor, School of Education,
PRIST Deemed to Be University, Thanjavur.

Curriculum design draws from various sources to ensure that educational programs are relevant, effective, and aligned with the needs of learners and society. Here are some key sources of curriculum design:

1. Educational Standards

- National, state, or local educational standards provide guidelines for what students should know and be able to do at each grade level. These standards help ensure consistency and quality across curricula.

2. Research and Best Practices

- Educational research provides insights into effective teaching and learning strategies. Best practices identified through studies in pedagogy, psychology, and cognitive science can inform curriculum design.

3. Societal Needs

- The curriculum should reflect the values, needs, and priorities of society. This includes incorporating skills and knowledge relevant to the job market, civic engagement, and social responsibility.

4. Cultural Context

- Recognizing and incorporating the diverse cultural backgrounds of students enhances the curriculum's relevance and inclusivity. This source emphasizes the importance of cultural responsiveness in education.

5. Learner Characteristics

- Understanding the characteristics, interests, and learning styles of students is crucial. Gathering data through assessments, surveys, and observations helps tailor the curriculum to meet diverse needs.

6. Teacher Expertise

- Teachers' knowledge, experiences, and professional development play a significant role in curriculum design. Their insights into effective practices and classroom realities can inform content and instructional strategies.

CHAPTER 9
Models of Curriculum
Prof. R. VAISHNAVI
Assistant professor, School of Education,
PRIST Deemed to Be University, Thanjavur.

Curriculum models provide frameworks for organizing and implementing educational programs. Each model offers a different approach to curriculum design and delivery, tailored to specific educational goals and contexts. Here are some prominent models of curriculum:

1. Subject-Centered Model

- Focuses on specific subjects or disciplines. The curriculum is organized around content areas, with an emphasis on knowledge acquisition in subjects like math, science, and literature.

2. Learner-Centered Model

- Prioritizes the interests, needs, and experiences of students. This model encourages active participation, exploration, and personalized learning paths, allowing students to take ownership of their learning.

3. Integrated Curriculum Model

- Combines multiple subjects or disciplines into thematic units. This approach emphasizes connections between areas of knowledge, promoting interdisciplinary learning and holistic understanding.

4. Outcome-Based Education (OBE)

- Focuses on specific learning outcomes and competencies that students should achieve by the end of a course or program. The curriculum is designed backward from these outcomes, ensuring alignment between goals, content, and assessment.

5. Problem-Based Learning (PBL)

- Engages students in real-world problems and scenarios, encouraging them to apply knowledge and critical thinking skills to find solutions. This model fosters collaboration and active inquiry.

6. Project-Based Learning (PBL)

- Students work on extended projects that require the integration of knowledge and skills from multiple disciplines. This model emphasizes creativity, critical thinking, and hands-on experiences.

CHAPTER 10

Curriculum change and Innovation Prof. T. SUBHASHINI Assistant professor, School of Education, PRIST Deemed to Be University, Thanjavur.

Curriculum change and innovation are vital processes in education that help ensure curricula remain relevant, effective, and responsive to the evolving needs of students and society. Here's an overview of both concepts:

Curriculum Change

1. Reasons for Change:

- **Societal Needs:** Changes in societal demands, such as new job skills or cultural shifts, often necessitate curriculum updates.
- **Educational Research:** Findings from educational research may indicate the need for new approaches, methodologies, or content areas.
- **Technological Advancements:** The rapid development of technology can require curricula to incorporate new tools, resources, and digital literacy skills.
- **Feedback and Evaluation:** Ongoing assessments and evaluations may reveal gaps or inefficiencies in the current curriculum that need addressing.

2. Types of Change:

- **Incremental Change:** Small adjustments to existing curricula, such as updating materials or modifying teaching strategies.
- **Transformational Change:** Major revisions that may involve a complete overhaul of the curriculum, adopting new educational philosophies, or implementing interdisciplinary approaches.

3. Process of Change:

- **Planning:** Identifying the need for change, setting clear goals, and involving stakeholders in the planning process to gain support.
- **Implementation:** Executing the changes, providing necessary training and resources, and ensuring all educators are prepared.
- **Evaluation:** Continuously assessing the effectiveness of the changes, gathering feedback, and making adjustments as needed.

Curriculum Innovation

1. **Definition:** Curriculum innovation involves introducing new ideas, methods, or approaches to enhance teaching and learning. It often seeks to improve student engagement, understanding, and outcomes.
2. **Sources of Innovation:**
 - **Research and Development:** Innovations often stem from educational research, pilot programs, and best practices identified in various educational contexts.
 - **Technology Integration:** The use of technology in the classroom, such as blended learning, online resources, and digital tools, can drive innovative practices.

PEDAGOGY OF HISTORY- PART – III

Edited by

T.SUBHASHINI



978-93-6255-288-4

Pedagogy of History: Part - III

Copyright ©2023-2024 by Prof. T. Subhashini

All rights reserved. No part of this book may be reproduced or transmitted in any form or by any means without written permission from the author.

ISBN:978-93-6255-288-4

Publisher: Ponnaiyah Ramajayam Institute of Science and Technology (PRIST)

TABLE OF CONTENTS

| | |
|---|-----|
| Introduction | 3 |
| CHAPTER I Nature and Scope of History | 16 |
| Prof. T. SUBHASHINI | |
| CHAPTER 2 Base of History Education | 28 |
| Prof. R. VAISHNAVI | |
| CHAPTER 3 Exploring Learners and Learning Resources | 51 |
| DR. P. SUBATRA | |
| CHAPTER 4 School Curriculum in History..... | 68 |
| DR. D. ARIVUMANI | |
| CHAPTER 5 Issues in Teaching and Learning History | 85 |
| DR. R. GUNASEKARAN | |
| CHAPTER 6 Evaluation | 109 |
| DR. R. GUNASEKARAN | |
| CHAPTER 7 The History Teacher | 126 |
| Prof. T. SUBHASHINI | |
| CHAPTER 8 Planning for Instruction | 137 |
| Prof. T. SELVARAJ | |
| CHAPTER 9 Models of Teaching | 156 |
| Prof. R. VAISHNAVI | |
| CHAPTER 10 Equipment and Resources for Teaching History | 165 |
| Prof. T. SUBHASHINI | |
| REFERENCES..... | 170 |

CHAPTER 1

Nature and Scope of History

Prof. T. SUBHASHINI

Assistant Professor, School of Education, PRIST Deemed to be University, Thanjavur

Nature of History:

History is the systematic study of past events, particularly how they shape societies, cultures, and human experiences over time. It seeks to understand the causes and effects of these events, the development of civilizations, and the relationships between individuals, communities, and nations. The nature of history involves:

1. **Subjectivity and Interpretation:** History is not just a collection of facts but includes interpretations by historians. Different perspectives often lead to different versions of historical events.
2. **Continuity and Change:** History explores both continuity and change over time, tracing how societies evolve or maintain traditions in response to internal and external influences.
3. **Causality and Consequence:** Historians examine causes of historical events and their outcomes, including unintended consequences.
4. **Evidence-Based:** History relies on primary and secondary sources like documents, artifacts, and eyewitness accounts. It uses these sources to reconstruct and analyze past events.
5. **Interdisciplinary:** History often overlaps with other fields like archaeology, anthropology, political science, and economics, to provide a broader understanding of past human activities.
6. **Contextual:** Historical events must be understood in their specific context—geographical, political, social, and cultural—since these contexts shape actions and decisions.

Scope of History:

The scope of history is vast and encompasses various dimensions, including:

1. **Chronological Scope:** It covers all periods, from prehistory to the contemporary era, allowing historians to track long-term developments as well as specific periods of rapid change.
2. **Geographical Scope:** History spans the globe, focusing on different civilizations, regions, and countries. This global perspective helps explain interactions and influences between diverse peoples and cultures.
3. **Thematic Scope:** History examines various themes such as political history, economic history, social history, cultural history, military history, and intellectual history. These thematic areas allow for specialized studies on topics like revolutions, industrialization, or artistic movements.

CHAPTER 2 **Base of History Education**

Prof. R. VAISHNAVI

Assistant Professor, School of Education, PRIST Deemed to be University, Thanjavur

Base of History Education:

The foundation of history education is built on several key principles and elements that aim to provide students with a deep understanding of the past and its relevance to the present and future. The base of history education can be described through the following components:

1. Chronological Understanding:

- **Concept of Time:** History education is grounded in the idea of teaching students to understand the concept of time—past, present, and future. This involves fostering a sense of historical periods, timelines, and the sequence of events.
- **Periodization:** Dividing history into distinct eras or periods (such as ancient, medieval, modern) helps students to organize historical knowledge systematically.

2. Critical Thinking and Analytical Skills:

- **Historical Inquiry:** Students learn to ask questions about the past—"what happened?", "why did it happen?", "how did it affect people?", and "what were its consequences?".
- **Source Evaluation:** A key component is teaching students to evaluate sources—primary (original documents or artifacts) and secondary (works by later historians)—to determine their reliability, bias, and significance.
- **Interpretation and Argumentation:** History is not just about memorizing facts but also about developing interpretations of past events and constructing evidence-based arguments.

3. Cultural and Social Awareness:

- **Diverse Perspectives:** History education emphasizes understanding different cultures, societies, and perspectives across time. This includes studying not just dominant narratives but also the histories of marginalized or less-represented groups.
- **Global and Local History:** Students are encouraged to make connections between local, national, and global events, understanding how history shapes identities and communities on multiple levels.

4. Historical Skills:

CHAPTER 3 Exploring Learners and Learning Resources

DR. P. SUBATRA

Assistant Professor, School of Education, PRIST Deemed to be University, Thanjavur

Exploring Learners and Learning Resources:

When designing educational experiences, especially in subjects like history, it's crucial to understand both **learners** and **learning resources**. These components shape how lessons are taught, how learners engage with content, and the effectiveness of educational outcomes. Let's explore these two areas:

1. Exploring Learners:

Understanding learners means recognizing their unique characteristics, needs, and learning styles. Some key aspects include:

A. Learner Characteristics:

- **Age and Developmental Stage:** The cognitive abilities of learners vary significantly by age. For example, younger students might need more concrete examples and visual aids, while older learners can handle abstract concepts and critical analysis.
- **Prior Knowledge and Experience:** Learners come with different backgrounds and knowledge levels. History, for example, may be more familiar to some students based on cultural exposure or previous lessons.
- **Learning Styles:** Some learners may be visual learners (preferring images, diagrams, or videos), others auditory (preferring discussions or lectures), and some kinesthetic (preferring hands-on or interactive learning).
- **Motivation and Interests:** Understanding what motivates learners—whether it's curiosity, grades, or personal interest in the subject—helps tailor instruction to keep them engaged.

B. Learner Needs:

- **Differentiated Instruction:** Learners have diverse needs, including those related to learning difficulties, language barriers, or giftedness. Differentiated instruction ensures that all learners, regardless of their abilities, can access the content.
- **Cultural Backgrounds:** Learners from different cultural backgrounds may have different perspectives on historical events. Recognizing this diversity allows educators to present content in a way that respects and incorporates various viewpoints.
- **Collaboration and Social Learning:** Many learners benefit from peer interactions, group work, and discussions, as history often involves the exploration of multiple

CHAPTER 4
School Curriculum in History
Dr. D. ARIVUMANI

Assistant Professor, School of Education, PRIST Deemed to be University, Thanjavur

School Curriculum in History:

A well-structured school history curriculum is essential to foster a deeper understanding of past events, cultures, and civilizations while promoting critical thinking and an appreciation for diversity. The curriculum is typically divided into key learning stages, focusing on the development of historical knowledge, skills, and perspectives. Here's an outline of what a school history curriculum generally encompasses:

1. Aims and Objectives of a History Curriculum:

The objectives of history education often include:

- **Knowledge Acquisition:** Gaining a strong foundation of significant historical events, figures, and processes.
- **Historical Understanding:** Developing a sense of chronology and the ability to analyze the causes and consequences of events.
- **Critical Thinking:** Encouraging students to think critically about sources, biases, and interpretations of history.
- **Civic Awareness:** Fostering an understanding of national identity and global citizenship.
- **Cultural Sensitivity:** Promoting an appreciation for the diversity of human experience and the ways in which different societies and cultures have evolved.

2. Structure of the History Curriculum:

The curriculum is typically structured across different educational stages, ensuring a progression in both complexity and content.

A. Primary Education (Elementary Level):

- **Introduction to Time and Chronology:** Students begin by learning basic concepts of time, such as past, present, and future. They also learn how to organize events on a timeline.
- **Local and Personal History:** At this stage, students often explore their own history and community, such as family traditions, local events, or historical landmarks in their area.
- **Key Historical Figures and Stories:** Students are introduced to famous historical figures and events through stories that are age-appropriate, often focusing on national heroes, explorers, or significant cultural achievements.
- **Historical Comparisons:** Simple comparisons are made between life in the past and the present, helping students understand changes over time.

CHAPTER 5

Issues in Teaching and Learning History

Dr. R. GUNASEKARAN

Assistant Professor, School of Education, PRIST Deemed to be University, Thanjavur

Issues in Teaching and Learning History:

Teaching and learning history come with a set of challenges that can impact both educators and students. These challenges range from the content and structure of the curriculum to the ways in which students engage with historical material. Here are some of the key issues that arise in history education:

1. Curriculum-Related Issues:

A. Overloaded Curriculum:

- **Too Much Content:** History curricula often attempt to cover a vast range of topics in limited time, which can lead to a superficial understanding of events. Teachers are pressured to "cover" content quickly, leaving little time for deep exploration of important issues.
- **Balancing Breadth and Depth:** It's difficult to strike a balance between teaching a broad overview of world history and providing in-depth analysis of specific events or themes. The breadth of content sometimes limits students' ability to delve deeply into any one period or event.

B. Eurocentrism and Narrow Perspectives:

- **Lack of Global Perspectives:** Many history curricula are criticized for focusing primarily on Western or Eurocentric perspectives. This can marginalize the histories of other regions, cultures, and groups, leading to a one-sided narrative.
- **Neglect of Local or Indigenous Histories:** National curricula often fail to incorporate the histories of indigenous peoples, local communities, or marginalized groups, which can alienate students from these backgrounds.

C. Controversial and Sensitive Topics:

- **Sensitive Issues:** Topics such as slavery, colonialism, genocide, and war are difficult to teach and may evoke strong emotions or resistance from students. Teachers need to handle these topics carefully, balancing sensitivity with the need for factual accuracy.
- **Historical Bias:** Textbooks and educational resources may present historical events in ways that reflect bias or outdated perspectives, making it challenging for students to critically assess historical narratives.

2. Student Engagement Issues:

CHAPTER 6

Evaluation

Dr. R. GUNASEKARAN

Assistant Professor, School of Education, PRIST Deemed to be University, Thanjavur

Evaluation in the context of education refers to the systematic process of assessing the effectiveness of teaching, learning, and educational strategies. It involves gathering and analyzing data to determine how well students are learning, how effectively instructional methods are working, and how educational objectives are being met. In the pedagogy of biological science, evaluation helps educators refine their teaching practices, assess student progress, and improve the curriculum.

Types of Evaluation in Education

1. Formative Evaluation

- **Definition:** Ongoing evaluations conducted during the teaching-learning process.
- **Purpose:** To monitor student learning and provide feedback that can be used to improve instruction and learning in real-time.
- **Examples:**
 - Classroom quizzes
 - Group discussions
 - Short feedback forms
 - Student reflections
- **Benefits:** Helps teachers adjust their teaching methods, address student misconceptions early, and guide students toward achieving learning goals.

2. Summative Evaluation

- **Definition:** Evaluation conducted at the end of a unit, course, or program to assess the overall effectiveness and achievement.
- **Purpose:** To evaluate student learning at the conclusion of an instructional period and to determine if the learning objectives were met.
- **Examples:**
 - Final exams
 - End-of-term projects
 - Standardized tests
 - Cumulative reports
- **Benefits:** Provides a comprehensive measure of student performance and curriculum effectiveness. Summative evaluations often inform grades and certifications.

3. Diagnostic Evaluation

- **Definition:** Pre-assessment conducted before instruction begins to understand students' prior knowledge and identify learning needs.
- **Purpose:** To identify strengths, weaknesses, and areas for improvement before the learning process starts.

CHAPTER 7

The History Teacher

Prof. T. SUBHASHINI

Assistant Professor, School of Education, PRIST Deemed to be University, Thanjavur

The History Teacher" can refer to a variety of contexts, including roles, teaching styles, and specific educators. Here are some key aspects related to being a history teacher:

1. Role and Responsibilities

- **Facilitator of Learning:** Create an engaging and inclusive classroom environment where students feel encouraged to explore historical topics.
- **Curriculum Designer:** Develop lesson plans that align with educational standards and address diverse learning needs.
- **Assessor:** Evaluate student understanding through various assessments, providing constructive feedback to support growth.

2. Teaching Strategies

- **Inquiry-Based Learning:** Encourage students to ask questions and conduct research to foster critical thinking and a deeper understanding of historical events.
- **Project-Based Learning:** Assign projects that allow students to explore historical topics in depth, promoting collaboration and creativity.
- **Use of Primary Sources:** Integrate documents, artifacts, and other primary sources to help students analyze different perspectives on historical events.

3. Engaging Students

- **Storytelling:** Use narratives to bring history to life, making it relatable and memorable for students.
- **Technology Integration:** Leverage digital tools and resources, such as interactive maps, virtual tours, and multimedia presentations, to enhance learning.
- **Field Trips and Experiential Learning:** Organize visits to historical sites, museums, or cultural events to provide real-world context.

4. Professional Development

- **Continuous Learning:** Stay updated on historical research, educational practices, and technology trends to enhance teaching effectiveness.
- **Collaboration:** Work with colleagues to share resources, strategies, and insights, fostering a supportive professional community.

5. Challenges Faced

CHAPTER 8

Planning for Instruction

Prof. T. SELVARAJ

Assistant Professor, School of Education, PRIST Deemed to be University, Thanjavur

Planning for instruction is a vital component of effective teaching, as it involves organizing and designing lessons to meet learning objectives, address student needs, and ensure that the content is delivered effectively. In the context of biological science, instructional planning focuses on how to best teach scientific concepts, theories, and skills, ensuring that students can not only understand the material but also apply it to real-world scenarios.

Key Steps in Planning for Instruction

1. Define Learning Objectives

- **Purpose:** Clear learning objectives outline what students should know, understand, and be able to do by the end of the lesson or unit.
- **Examples:**
 - "Students will be able to explain the process of photosynthesis."
 - "Students will analyze the role of natural selection in evolution."
- **SMART Criteria:** Learning objectives should be **S**pecific, **M**easurable, **A**chievable, **R**elevant, and **T**ime-bound to ensure clarity and focus.

2. Identify and Align Curriculum Standards

- **Purpose:** Instruction must align with national, state, or local curriculum standards to ensure consistency and comprehensiveness.
- **Examples:** For biology, this may include standards related to genetics, ecosystems, evolution, and cell biology.
- **Benefits:** Ensures that instruction covers essential content and skills, helping students meet academic expectations.

3. Understand Student Needs and Context

- **Purpose:** Tailoring instruction to meet the diverse needs of learners.
- **Considerations:**
 - **Learning styles:** Some students may be visual learners, while others prefer hands-on activities or verbal instruction.
 - **Prior knowledge:** Assessing what students already know helps guide the depth of instruction.
 - **Diverse learning needs:** Differentiating instruction for students with special needs, language barriers, or advanced abilities is essential.
- **Examples:** Using models and diagrams for visual learners, or incorporating group activities for kinesthetic learners.

4. Select and Organize Content

- **Purpose:** Identify the key concepts, facts, and skills to be taught and decide the sequence in which they will be presented.

CHAPTER 9
Models of Teaching
Prof. R. VAISHNAVI

Assistant Professor, School of Education, PRIST Deemed to be University, Thanjavur

Models of teaching refer to structured, systematic approaches to instruction that help guide the teaching process to achieve specific learning outcomes. These models are based on theories of learning and development and provide educators with frameworks for organizing and delivering content, fostering student engagement, and promoting the effective acquisition of knowledge and skills. Each model emphasizes different aspects of learning and teaching, and the choice of model depends on the subject matter, learning objectives, and the needs of the students.

Here are some of the most widely recognized models of teaching:

1. The Direct Instruction Model

- **Definition:** A teacher-centered approach that emphasizes clear, structured, and explicit teaching of content or skills.
- **Key Features:**
 - Focus on mastery of content through systematic instruction.
 - The teacher leads the lesson by providing information, modeling, and giving guided practice.
 - Frequent feedback and correction are given to ensure understanding.
 - Lesson phases: Introduction, Presentation, Guided Practice, Independent Practice, and Closure.
- **Advantages:**
 - Highly effective for teaching foundational skills, especially in areas like math, reading, or basic biology concepts.
 - Structured and efficient, which makes it ideal for covering large amounts of content.
- **Disadvantages:**
 - Less emphasis on critical thinking and creativity.
 - Limits student autonomy and may not engage all learners.

Example in Biology: Teaching the structure of the cell by explaining and modeling the parts, providing guided practice through labeling exercises, and then assigning independent activities like cell diagram creation.

2. The Inquiry-Based Learning Model

- **Definition:** A student-centered approach that encourages students to ask questions, investigate problems, and discover answers through exploration.

CHAPTER 10

Equipment and Resources for Teaching History

Prof. T. SUBHASHINI

Assistant Professor, School of Education, PRIST Deemed to be University, Thanjavur

Equipment and Resources for Teaching History:

Teaching history effectively requires a variety of tools and resources to engage students, make historical events come alive, and promote critical thinking. These resources can be physical, digital, or human, each contributing to a rich learning experience. Below is an overview of key equipment and resources for teaching history:

1. Physical Resources:

A. Textbooks and Supplementary Books:

- **History Textbooks:** These provide the foundational content and structure for the history curriculum. Well-designed textbooks offer narratives, maps, timelines, and illustrations to help students understand historical events.
- **Supplementary Books:** These include biographies, historical fiction, and thematic books that can provide deeper insights into specific events, eras, or individuals.

B. Maps and Globes:

- **Historical Maps:** Maps are essential for teaching geography in relation to history. Teachers can use them to show the locations of key events, shifting borders, trade routes, and migrations.
- **Timelines:** Large, visual timelines that show key events help students understand the sequence and context of historical developments.

C. Artifacts and Replicas:

- **Historical Artifacts:** Real or replica artifacts, such as ancient tools, clothing, weapons, coins, and art, provide tangible connections to the past. These can be used in hands-on activities to give students a sense of how people lived in different eras.
- **Primary Source Replicas:** Copies of important documents, like the Magna Carta, U.S. Constitution, or letters from historical figures, allow students to directly engage with primary sources.



PEDAGOGY OF ECONOMICS: PART – III

EDITED BY
R.VAISHNAVI

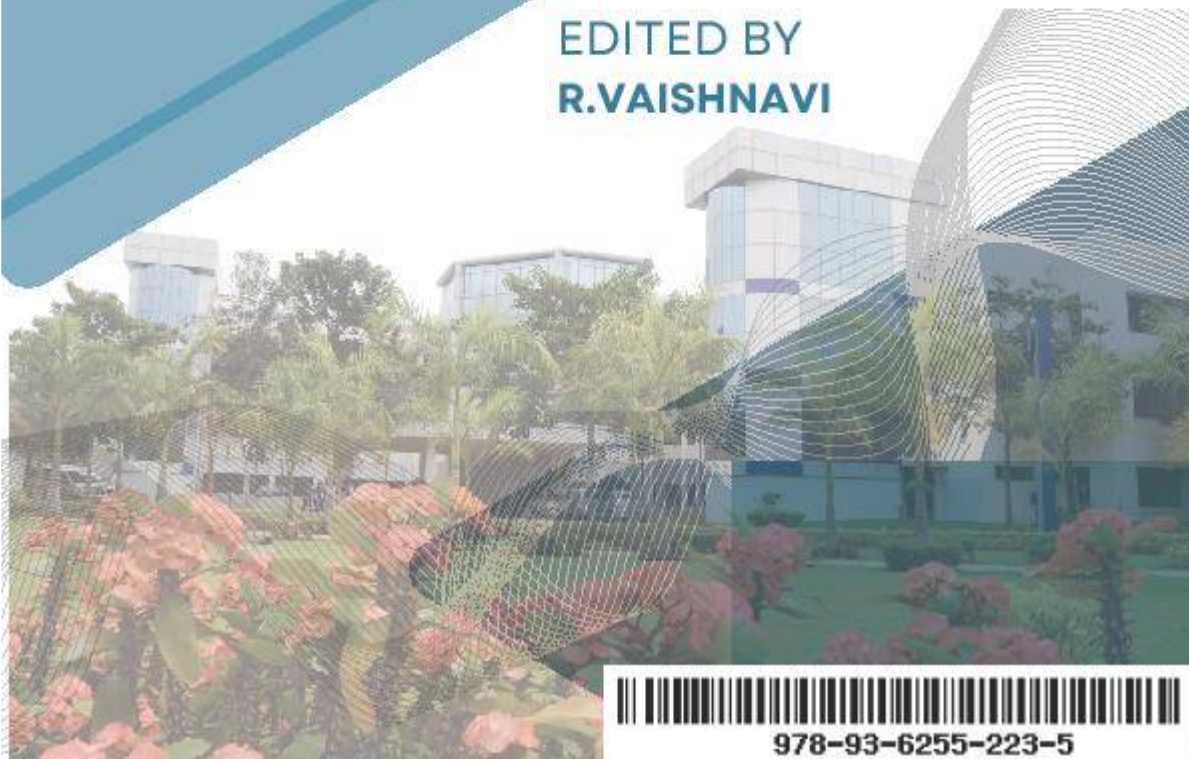

978-93-6255-223-5

Pedagogy of Economics: Part – III
Copyright ©2023-2024 by Prof. R. Vaishnavi

All rights reserved. No part of this book may be reproduced or transmitted in any form or by any means without written permission from the author.

ISBN:978-93-6255-223-5

Publisher: Ponnaiyah Ramajayam Institute of Science and Technology (PRIST)

TABLE OF CONTENTS

| | |
|---|-----|
| Introduction | 3 |
| CHAPTER 1 Nature and Scope of Economics | 16 |
| Prof. R. VAISHNAVI | |
| CHAPTER 2 Base of Economics Education..... | 28 |
| Prof. T. SUBHASHINI | |
| CHAPTER 3 Exploring Learners and Methods of Teaching | 51 |
| Prof. T. SELVARAJ | |
| CHAPTER 4 School Curriculum in Economics..... | 68 |
| DR. R. GUNASEKARAN | |
| CHAPTER 5 Role of Educational organizations..... | 85 |
| Prof. R. VAISHNAVI | |
| CHAPTER 6 Evaluation | 109 |
| DR. R. GUNASEKARAN | |
| CHAPTER 7 The Economics Teacher | 126 |
| Prof. R. VAISHNAVI | |
| CHAPTER 8 Planning for Instruction | 137 |
| Prof. T. SELVARAJ | |
| CHAPTER 9 Models of Teaching | 156 |
| Prof. R. VAISHNAVI | |
| CHAPTER 10 Equipment and Resources for Teaching Economics..... | 165 |
| Prof. R. VAISHNAVI | |
| REFERENCES..... | 170 |

CHAPTER I

Nature and Scope of Economics

Prof. R. VAISHNAVI

Assistant Professor, School of Education, PRIST Deemed to be University, Thanjavur

The **nature and scope of economics** encompass the study of how individuals, businesses, and societies allocate scarce resources to meet their needs and desires. Here's a detailed overview:

Nature of Economics

- 1. Social Science:**
 - Economics is classified as a social science because it examines human behavior and societal interactions, focusing on how people make choices regarding the use of resources.
- 2. Study of Scarcity:**
 - At its core, economics addresses the problem of scarcity, which arises because resources (land, labor, capital) are limited, while human wants are virtually unlimited. This fundamental concept leads to the necessity of making choices.
- 3. Resource Allocation:**
 - Economics investigates how resources are distributed among various uses and how decisions are made to maximize satisfaction or utility. It explores methods for efficient allocation to minimize waste and meet societal needs.
- 4. Micro and Macro Perspectives:**
 - **Microeconomics:** Focuses on individual agents, such as consumers and firms, and how their interactions determine prices and output in specific markets.
 - **Macroeconomics:** Examines the economy as a whole, addressing aggregate phenomena like national income, unemployment, inflation, and economic growth.
- 5. Positive and Normative Economics:**
 - **Positive Economics:** Concerned with what is; it analyzes and describes economic phenomena based on factual evidence and data.
 - **Normative Economics:** Focuses on what ought to be; it involves value judgments and opinions about economic policies and outcomes.
- 6. Dynamic and Evolving Discipline:**
 - Economics is not static; it adapts to changes in technology, society, and government policies. It incorporates new theories and models to better understand and explain economic behavior.

Scope of Economics

- 1. Production:**
 - Studies how goods and services are produced, the factors of production (land, labor, capital), and the technologies used in production processes. It also examines the organization of production, including different types of business structures.
- 2. Consumption:**

CHAPTER 2 **Base of Economics Education**

Prof. T. SUBHASHINI

Assistant Professor, School of Education, PRIST Deemed to be University, Thanjavur

The **base of economics education** refers to the foundational principles, concepts, and skills necessary for understanding and applying economic theories and practices. Here's a comprehensive overview:

1. Fundamental Concepts

- **Scarcity:** Understanding that resources are limited and choices must be made about their allocation.
- **Supply and Demand:** Grasping how market forces interact to determine prices and quantities in various markets.
- **Opportunity Cost:** Recognizing the value of the next best alternative foregone when making a decision.
- **Utility:** Understanding the satisfaction or benefit derived from consuming goods and services.

2. Economic Principles

- **Microeconomic Principles:** Focus on individual consumers and firms, covering topics like market structures, elasticity, and consumer behavior.
- **Macroeconomic Principles:** Address aggregate economic phenomena, including national income, inflation, unemployment, and economic growth.
- **Comparative Advantage:** Understanding the benefits of trade and specialization among individuals and nations.

3. Analytical Skills

- **Critical Thinking:** Developing the ability to analyze economic problems, evaluate evidence, and assess policies.
- **Quantitative Skills:** Gaining proficiency in interpreting and manipulating data, using statistical tools, and understanding graphs and models.

4. Research Methods

- **Data Analysis:** Learning how to collect, analyze, and interpret economic data from various sources, such as government reports and financial statements.
- **Case Studies:** Engaging with real-world scenarios to apply theoretical knowledge and explore economic decision-making processes.

5. Economic Theories and Models

CHAPTER 3 Exploring Learners and Methods of Teaching

Prof. T. SELVARAJ

Assistant Professor, School of Education, PRIST Deemed to be University, Thanjavur

Exploring learners and methods of teaching involves understanding the diverse needs, backgrounds, and learning styles of students, as well as employing various teaching strategies to effectively facilitate learning. Here's a comprehensive overview:

Understanding Learners

1. Diversity of Learners:

- **Cultural Backgrounds:** Students come from various cultural contexts that influence their perspectives, values, and learning preferences.
- **Learning Styles:** Some learners may prefer visual aids, while others benefit from auditory or kinesthetic learning experiences. Common learning styles include:
 - **Visual Learners:** Prefer images, diagrams, and charts.
 - **Auditory Learners:** Learn best through listening and discussion.
 - **Kinesthetic Learners:** Prefer hands-on activities and movement.

2. Developmental Stages:

- Understanding cognitive development, as outlined by theorists like Piaget and Vygotsky, helps tailor instruction to match learners' developmental stages.
- Consideration of emotional and social development is also essential for fostering a supportive learning environment.

3. Motivation and Engagement:

- Recognizing the factors that motivate learners—intrinsic (personal interest) and extrinsic (rewards, grades)—can enhance engagement.
- Strategies to foster motivation include goal-setting, relevance to real-world contexts, and opportunities for choice in learning activities.

4. Individual Differences:

- Accommodating learners with special needs (e.g., learning disabilities, gifted students) requires differentiated instruction and tailored approaches.
- Building relationships with students helps identify their unique strengths and challenges, fostering a more inclusive environment.

Methods of Teaching

1. Lecture-Based Teaching:

- **Description:** Traditional approach where the teacher delivers content to students.
- **Advantages:** Efficient for delivering large amounts of information and foundational knowledge.
- **Techniques:** Use of slides, multimedia presentations, and structured outlines.

CHAPTER 4
School Curriculum in Economics
DR. R. GUNASEKARAN

Assistant Professor, School of Education, PRIST Deemed to be University, Thanjavur

School curriculum in economics is designed to provide students with a foundational understanding of economic principles, theories, and their applications. Here's an overview of what a comprehensive economics curriculum might include:

1. Curriculum Goals and Objectives

- **Understanding Economic Principles:** Equip students with knowledge of key economic concepts such as supply and demand, opportunity cost, and market structures.
- **Critical Thinking:** Foster analytical skills to evaluate economic issues, policies, and decisions.
- **Real-World Applications:** Connect theoretical concepts to current events and real-life scenarios, encouraging students to apply their knowledge.

2. Core Content Areas

- **Microeconomics:**
 - **Demand and Supply:** Understanding market dynamics, price determination, and the role of consumers and producers.
 - **Elasticity:** Exploring how quantity demanded or supplied responds to price changes.
 - **Market Structures:** Analyzing different market forms, such as perfect competition, monopoly, and oligopoly.
 - **Consumer Behavior:** Examining how consumers make choices based on preferences and budget constraints.
- **Macroeconomics:**
 - **National Income:** Understanding measures of economic performance, including GDP and GNP.
 - **Inflation and Unemployment:** Analyzing causes and effects, as well as policies to address these issues.
 - **Fiscal and Monetary Policy:** Exploring government policies on taxation, spending, and central bank actions to influence the economy.
 - **Economic Growth and Development:** Examining factors contributing to economic growth and the challenges faced by developing economies.
- **International Economics:**
 - **Trade Theories:** Understanding comparative advantage and the benefits of international trade.
 - **Exchange Rates:** Exploring how currencies are valued and the impact of fluctuations on trade.
 - **Globalization:** Analyzing the economic effects of global interconnectedness and trade agreements.

CHAPTER 5

Role of Educational organizations

Prof. R. VAISHNAVI

Assistant Professor, School of Education, PRIST Deemed to be University, Thanjavur

Educational organizations play a crucial role in shaping the educational landscape, promoting effective teaching and learning, and supporting various stakeholders in the education sector. Here's an overview of their roles:

1. Curriculum Development and Standards

- **Setting Standards:** Establishing academic standards and benchmarks for educational programs to ensure consistency and quality across schools.
- **Curriculum Design:** Developing and revising curricula that align with educational goals, societal needs, and workforce demands.

2. Professional Development

- **Training and Workshops:** Providing professional development opportunities for educators to enhance their teaching skills, knowledge, and instructional strategies.
- **Certification and Licensing:** Overseeing the certification process for teachers and administrators, ensuring they meet the necessary qualifications and standards.

3. Research and Policy Advocacy

- **Conducting Research:** Engaging in research to analyze educational practices, outcomes, and innovations, contributing to evidence-based decision-making.
- **Advocating for Policies:** Promoting policies that support educational equity, funding, and access to quality education for all students.

4. Support and Resources

- **Educational Resources:** Offering resources, tools, and materials to educators, including textbooks, technology, and teaching aids.
- **Technical Assistance:** Providing guidance and support to schools and educators in implementing effective practices and programs.

5. Collaboration and Networking

- **Building Partnerships:** Fostering collaboration among schools, community organizations, businesses, and higher education institutions to support educational initiatives.
- **Networking Opportunities:** Creating platforms for educators to connect, share experiences, and learn from one another through conferences and professional organizations.

CHAPTER 6

Evaluation

DR. R. GUNASEKARAN

Assistant Professor, School of Education, PRIST Deemed to be University, Thanjavur

Evaluation in the context of education refers to the systematic process of assessing the effectiveness of teaching, learning, and educational strategies. It involves gathering and analyzing data to determine how well students are learning, how effectively instructional methods are working, and how educational objectives are being met. In the pedagogy of biological science, evaluation helps educators refine their teaching practices, assess student progress, and improve the curriculum.

Types of Evaluation in Education

1. Formative Evaluation

- **Definition:** Ongoing evaluations conducted during the teaching-learning process.
- **Purpose:** To monitor student learning and provide feedback that can be used to improve instruction and learning in real-time.
- **Examples:**
 - Classroom quizzes
 - Group discussions
 - Short feedback forms
 - Student reflections
- **Benefits:** Helps teachers adjust their teaching methods, address student misconceptions early, and guide students toward achieving learning goals.

2. Summative Evaluation

- **Definition:** Evaluation conducted at the end of a unit, course, or program to assess the overall effectiveness and achievement.
- **Purpose:** To evaluate student learning at the conclusion of an instructional period and to determine if the learning objectives were met.
- **Examples:**
 - Final exams
 - End-of-term projects
 - Standardized tests
 - Cumulative reports
- **Benefits:** Provides a comprehensive measure of student performance and curriculum effectiveness. Summative evaluations often inform grades and certifications.

3. Diagnostic Evaluation

- **Definition:** Pre-assessment conducted before instruction begins to understand students' prior knowledge and identify learning needs.
- **Purpose:** To identify strengths, weaknesses, and areas for improvement before the learning process starts.

CHAPTER 7

The Economics Teacher

Prof. R. VAISHNAVI

Assistant Professor, School of Education, PRIST Deemed to be University, Thanjavur

The role of an **economics teacher** encompasses a range of responsibilities, skills, and attributes aimed at fostering students' understanding of economic concepts and their application in the real world. Here's an overview of what defines a successful economics teacher:

1. Subject Matter Expertise

- **Deep Understanding:** An effective economics teacher has a strong foundation in both microeconomics and macroeconomics, as well as familiarity with specialized areas such as behavioral economics, international trade, and public policy.
- **Current Knowledge:** Staying updated on global economic trends, policies, and contemporary issues is essential to connect classroom learning with real-world events.

2. Pedagogical Skills

- **Effective Communication:** The ability to convey complex economic ideas clearly and concisely is crucial. An economics teacher should tailor their explanations to suit various learning levels.
- **Engagement Strategies:** Utilizing various teaching methods, such as discussions, debates, and hands-on activities, helps maintain student interest and involvement.

3. Instructional Techniques

- **Interactive Learning:** Incorporating group work, case studies, and simulations encourages active participation and helps students apply theoretical knowledge to practical scenarios.
- **Use of Technology:** Integrating digital tools, such as economic simulations, online resources, and statistical software, enhances learning and keeps students engaged.

4. Assessment and Feedback

- **Variety of Assessment Methods:** Employing formative assessments (quizzes, discussions) and summative assessments (exams, projects) provides a comprehensive view of student understanding.
- **Constructive Feedback:** Timely and specific feedback helps students identify areas for improvement and encourages continuous learning.

5. Critical Thinking and Problem Solving

- **Promoting Analytical Skills:** Encouraging students to analyze economic data, evaluate policies, and consider multiple perspectives on economic issues fosters critical thinking.

CHAPTER 8

Planning for Instruction

Prof. T. SELVARAJ

Assistant Professor, School of Education, PRIST Deemed to be University, Thanjavur

Planning for instruction is a vital component of effective teaching, as it involves organizing and designing lessons to meet learning objectives, address student needs, and ensure that the content is delivered effectively. In the context of biological science, instructional planning focuses on how to best teach scientific concepts, theories, and skills, ensuring that students can not only understand the material but also apply it to real-world scenarios.

Key Steps in Planning for Instruction

1. **Define Learning Objectives**
 - **Purpose:** Clear learning objectives outline what students should know, understand, and be able to do by the end of the lesson or unit.
 - **Examples:**
 - "Students will be able to explain the process of photosynthesis."
 - "Students will analyze the role of natural selection in evolution."
 - **SMART Criteria:** Learning objectives should be **S**pecific, **M**easurable, **A**chievable, **R**elevant, and **T**ime-bound to ensure clarity and focus.
2. **Identify and Align Curriculum Standards**
 - **Purpose:** Instruction must align with national, state, or local curriculum standards to ensure consistency and comprehensiveness.
 - **Examples:** For biology, this may include standards related to genetics, ecosystems, evolution, and cell biology.
 - **Benefits:** Ensures that instruction covers essential content and skills, helping students meet academic expectations.
3. **Understand Student Needs and Context**
 - **Purpose:** Tailoring instruction to meet the diverse needs of learners.
 - **Considerations:**
 - **Learning styles:** Some students may be visual learners, while others prefer hands-on activities or verbal instruction.
 - **Prior knowledge:** Assessing what students already know helps guide the depth of instruction.
 - **Diverse learning needs:** Differentiating instruction for students with special needs, language barriers, or advanced abilities is essential.
 - **Examples:** Using models and diagrams for visual learners, or incorporating group activities for kinesthetic learners.
4. **Select and Organize Content**
 - **Purpose:** Identify the key concepts, facts, and skills to be taught and decide the sequence in which they will be presented.
 - **Examples:**
 - Teaching cellular biology before diving into genetics, as students need to understand cell structures and functions before learning about DNA.

CHAPTER 9
Models of Teaching
Prof. R. VAISHNAVI

Models of teaching refer to structured, systematic approaches to instruction that help guide the teaching process to achieve specific learning outcomes. These models are based on theories of learning and development and provide educators with frameworks for organizing and delivering content, fostering student engagement, and promoting the effective acquisition of knowledge and skills. Each model emphasizes different aspects of learning and teaching, and the choice of model depends on the subject matter, learning objectives, and the needs of the students.

Here are some of the most widely recognized models of teaching:

1. The Direct Instruction Model

- **Definition:** A teacher-centered approach that emphasizes clear, structured, and explicit teaching of content or skills.
- **Key Features:**
 - Focus on mastery of content through systematic instruction.
 - The teacher leads the lesson by providing information, modeling, and giving guided practice.
 - Frequent feedback and correction are given to ensure understanding.
 - Lesson phases: Introduction, Presentation, Guided Practice, Independent Practice, and Closure.
- **Advantages:**
 - Highly effective for teaching foundational skills, especially in areas like math, reading, or basic biology concepts.
 - Structured and efficient, which makes it ideal for covering large amounts of content.
- **Disadvantages:**
 - Less emphasis on critical thinking and creativity.
 - Limits student autonomy and may not engage all learners.

Example in Biology: Teaching the structure of the cell by explaining and modeling the parts, providing guided practice through labeling exercises, and then assigning independent activities like cell diagram creation.

2. The Inquiry-Based Learning Model

- **Definition:** A student-centered approach that encourages students to ask questions, investigate problems, and discover answers through exploration.
- **Key Features:**
 - Students are active participants in the learning process, conducting experiments, investigations, or research.
 - Emphasis on higher-order thinking skills such as analysis, synthesis, and evaluation.

CHAPTER 10

Equipment and Resources for Teaching Economics Prof. R. VAISHNAVI

Assistant Professor, School of Education, PRIST Deemed to be University, Thanjavur

Effective teaching of economics requires a variety of equipment and resources that enhance learning and engagement. Here's an overview of essential tools and materials for teaching economics:

1. Textbooks and Reference Materials

- **Core Textbooks:** Comprehensive textbooks that cover fundamental economic concepts, theories, and real-world applications.
- **Supplementary Readings:** Articles, papers, and case studies that provide current examples and in-depth analysis of economic issues.

2. Digital Resources

- **Online Learning Platforms:** Websites that offer courses, modules, and quizzes related to economics, such as Khan Academy or Coursera.
- **E-books and Journals:** Access to electronic books and academic journals for research and further reading.

3. Multimedia Tools

- **Presentation Software:** Tools like PowerPoint or Google Slides for creating engaging lectures and visual aids.
- **Videos and Documentaries:** Educational videos that explain economic concepts or provide real-world examples, available on platforms like YouTube or educational streaming services.

4. Simulations and Games

- **Economic Simulations:** Software or online platforms that simulate market dynamics, trade, and decision-making processes, such as "SimCity" or "Economics Challenge."
- **Board Games:** Games like "Monopoly" or "The Game of Life" that illustrate economic principles in a fun and engaging manner.

5. Data Analysis Tools

- **Spreadsheet Software:** Programs like Microsoft Excel or Google Sheets for analyzing economic data, creating charts, and performing calculations.
- **Statistical Software:** Tools like R or SPSS for more advanced data analysis and visualization.



PEDAGOGY OF COMMERCE AND ACCOUNTANCY- PART – III



Edited by
R.VAISHNAVI



978-93-6255-263-1

Pedagogy of Commerce and Accountancy: Part – III
Copyright ©2023-2024 by Prof. R. Vaishnavi

All rights reserved. No part of this book may be reproduced or transmitted in any form or by any means without written permission from the author.

ISBN:978-93-6255-263-1

Publisher: Ponnaiyah Ramajayam Institute of Science and Technology (PRIST)

TABLE OF CONTENTS

| | |
|--|-----|
| Introduction | 3 |
| CHAPTER I The Origin and Development of Ancient Trade Practice | 16 |
| Prof. T. SUBHASHINI | |
| CHAPTER 2 The Role of Transport and Ware Houses in The Development of Commerce | 28 |
| Prof. R. VAISHNAVI | |
| CHAPTER 3 Commercial Services of Banks..... | 51 |
| Prof. T. SELVARAJ | |
| CHAPTER 4 Insurance | 68 |
| DR. R. GUNASEKARAN | |
| CHAPTER 5 Advertisement | 85 |
| DR. J. DEEPA | |
| CHAPTER 6 Evaluation | 109 |
| DR. R. GUNASEKARAN | |
| CHAPTER 7 The Commerce and Accountancy Teacher | 126 |
| Prof. R. VAISHNAVI | |
| CHAPTER 8 Planning for Instruction | 137 |
| Prof. T. SELVARAJ | |
| CHAPTER 9 Models..... | 156 |
| Prof. R. VAISHNAVI | |
| CHAPTER 10 Equipment and Resources for Teaching Commerce and Accountancy | 165 |
| Prof. R. VAISHNAVI | |
| REFERENCES..... | 170 |

CHAPTER I

The Origin and Development of Ancient Trade Practice

Prof. T. SUBHASHINI

Assistant Professor, School of Education, PRIST Deemed to be University, Thanjavur

The origin and development of ancient trade practices are foundational to the understanding of commerce and economic systems throughout history. Here's an overview of how trade evolved in ancient civilizations:

1. Early Trade Practices

- **Barter System:** Initially, trade was conducted through barter, where goods and services were directly exchanged without a standard currency. Early societies exchanged surplus goods, such as agricultural products or crafted items.
- **Emergence of Money:** As trade expanded, the limitations of barter became apparent. The need for a more efficient medium of exchange led to the development of money, initially in the form of commodities (like grain or livestock) and later as metal coins.

2. Geographic Influence on Trade

- **River Valleys:** Ancient civilizations often developed along major rivers (e.g., the Nile, the Tigris and Euphrates) which facilitated transportation and trade. These waterways allowed for the easy movement of goods, fostering regional trade networks.
- **Trade Routes:** Overland trade routes, such as the Silk Road, connected different cultures and regions, facilitating the exchange of goods like silk, spices, and precious metals. Maritime trade routes also developed, allowing for trade between coastal cities.

3. Key Ancient Civilizations and Their Trade Practices

- **Mesopotamia:** The Sumerians were among the first to engage in trade, using cuneiform tablets to record transactions. They traded textiles, grains, and tools with neighboring regions.
- **Ancient Egypt:** Trade in Egypt was vital for acquiring resources not found in the Nile region, such as cedar wood from Lebanon and gold from Nubia. The state controlled trade, ensuring stability and regulation.
- **Indus Valley Civilization:** Known for its advanced urban planning, cities like Harappa and Mohenjo-Daro engaged in trade with Mesopotamia and other regions, exchanging beads, cotton textiles, and metals.
- **Ancient China:** The development of the Silk Road facilitated trade of silk, tea, and porcelain. Chinese dynasties regulated trade, leading to significant economic growth and cultural exchange.
- **Greek and Roman Trade:** The Greeks established trade networks across the Mediterranean, exporting olive oil and wine. The Romans expanded these networks, integrating vast territories into a cohesive economy through roads and maritime routes.

CHAPTER 2
The Role of Transport and Ware Houses in
The Development of Commerce

Prof. R. VAISHNAVI

Assistant Professor, School of Education, PRIST Deemed to be University, Thanjavur

The role of transport and warehouses in commerce and trade is crucial, as they facilitate the movement and storage of goods, thereby enhancing efficiency and reliability in supply chains. Here's a detailed overview of their significance:

1. Role of Transport

A. Movement of Goods

- **Accessibility:** Transport systems enable goods to move from producers to consumers, connecting various markets and regions. Efficient transportation networks reduce travel time and costs.
- **Types of Transport:** Various modes, including road, rail, air, and maritime transport, serve different needs. For example, air transport is used for high-value, time-sensitive goods, while maritime transport is ideal for bulk items.

B. Trade Expansion

- **Global Trade:** Advances in transportation have facilitated international trade by connecting distant markets. This globalization has allowed businesses to access new customers and suppliers.
- **Regional Development:** Improved transport infrastructure contributes to regional economic development by enhancing trade capabilities and attracting investments.

C. Cost Efficiency

- **Economies of Scale:** Efficient transport allows businesses to achieve economies of scale by enabling bulk transportation, reducing per-unit costs.
- **Supply Chain Optimization:** Effective transportation logistics can streamline supply chains, minimizing delays and improving overall efficiency.

2. Role of Warehouses

A. Storage of Goods

- **Inventory Management:** Warehouses provide a space to store goods, enabling businesses to manage inventory levels effectively. This helps in meeting demand without excessive stockholding.
- **Buffer against Demand Fluctuations:** Warehousing allows companies to maintain a buffer stock, ensuring that they can respond to sudden spikes in demand without disruptions.

CHAPTER 3

Commercial Services of Banks

Prof. T. SELVARAJ

Assistant Professor, School of Education, PRIST Deemed to be University, Thanjavur

Commercial banks provide a variety of services that are essential for individuals, businesses, and the economy. Here's an overview of the key commercial services offered by banks:

1. Deposit Accounts

- **Savings Accounts:** Allow individuals to deposit money while earning interest, providing liquidity and a safe place to save.
- **Current Accounts:** Designed for businesses and individuals who need to conduct frequent transactions, offering features like check writing and overdraft facilities.

2. Loans and Credit Facilities

- **Personal Loans:** Unsecured loans for personal expenses, such as home improvements or medical bills.
- **Business Loans:** Financial support for small and large enterprises, helping them fund operations, expand, or invest in equipment.
- **Mortgages:** Long-term loans specifically for purchasing property, usually secured against the property itself.
- **Credit Cards:** Provide a line of credit that allows consumers to make purchases and pay back over time, often with interest.

3. Payment and Transaction Services

- **Fund Transfers:** Facilitate transfers of funds between accounts, both domestically and internationally, through services like wire transfers or electronic funds transfer (EFT).
- **Online and Mobile Banking:** Allow customers to manage their accounts, pay bills, and transfer money using digital platforms, enhancing convenience and accessibility.

4. Investment Services

- **Wealth Management:** Offer investment advice and portfolio management services for individuals and businesses looking to grow their wealth.
- **Mutual Funds and Securities:** Provide access to investment products, allowing customers to invest in stocks, bonds, and other financial instruments.

5. Foreign Exchange Services

- **Currency Exchange:** Facilitate the exchange of one currency for another, essential for individuals traveling abroad or businesses engaged in international trade.

CHAPTER 4

Insurance

DR. R. GUNASEKARAN

Assistant Professor, School of Education, PRIST Deemed to be University, Thanjavur

Insurance is a financial mechanism that provides protection against financial loss or risk. It involves the transfer of risk from an individual or business to an insurance company, which agrees to compensate for certain losses in exchange for regular premium payments. Here's an overview of key concepts, types, and functions of insurance:

1. Basic Concepts of Insurance

- **Premium:** The amount paid by the policyholder to the insurance company for coverage. It can be paid monthly, quarterly, or annually.
- **Policy:** A contract between the insurer and the insured, outlining the terms, coverage, and conditions of the insurance.
- **Deductible:** The amount the policyholder must pay out-of-pocket before the insurance coverage kicks in for a claim.
- **Coverage:** The specific risks or losses that the insurance policy protects against, such as accidents, theft, or natural disasters.

2. Types of Insurance

A. Life Insurance

- **Term Life Insurance:** Provides coverage for a specific period (e.g., 10, 20 years) and pays a death benefit if the insured passes away during that term.
- **Whole Life Insurance:** Offers lifelong coverage with a savings component, accumulating cash value over time.

B. Health Insurance

- **Individual Health Insurance:** Covers medical expenses for individuals, including doctor visits, hospital stays, and medications.
- **Group Health Insurance:** Offered by employers to employees, often at a lower cost than individual policies.

C. Property Insurance

- **Homeowners Insurance:** Protects against damages to a home and personal belongings due to events like fire, theft, or natural disasters.
- **Renters Insurance:** Covers personal belongings in a rented property against similar risks.

CHAPTER 5
Advertisement
Dr. J. DEEPA

Assistant Professor, School of Education, PRIST Deemed to be University, Thanjavur

Advertisement is a form of communication used by businesses, organizations, or individuals to promote their products, services, or ideas to a target audience. It aims to inform, persuade, and influence potential customers, with the ultimate goal of encouraging a purchase or some other form of desired action. Advertisements appear in various media, including television, radio, newspapers, magazines, online platforms, and more.

1. Purpose of Advertisement

- **Informing:** Ads are designed to inform potential customers about a product's features, benefits, price, and availability.
- **Persuading:** Advertisements aim to persuade people to choose a particular product over competitors' products by highlighting its unique selling points.
- **Reminding:** Ads can remind existing customers of a brand or product, ensuring it stays top of mind.
- **Branding:** Advertisement helps in creating or strengthening brand identity and loyalty.

2. Types of Advertisements

A. Print Advertising

- **Newspapers and Magazines:** Traditional forms of print ads that target readers of specific publications. Newspaper ads can be used for general awareness, while magazine ads tend to target more niche audiences.
- **Brochures, Flyers, and Posters:** Used for local or targeted campaigns, particularly for events or small businesses.

B. Broadcast Advertising

- **Television:** One of the most powerful and expensive forms of advertising. It reaches a broad audience and uses visual and auditory elements to create engaging and persuasive messages.
- **Radio:** Audio ads that reach a wide audience and can be targeted based on time of day or radio station demographics.

C. Digital Advertising

- **Search Engine Ads:** Ads that appear in search engine results, such as Google Ads, targeting users searching for specific keywords related to the product or service.
- **Social Media Ads:** Platforms like Facebook, Instagram, and LinkedIn allow businesses to target specific audiences based on interests, location, demographics, and more.

CHAPTER 6

Evaluation

DR. R. GUNASEKARAN

Assistant Professor, School of Education, PRIST Deemed to be University, Thanjavur

Evaluation in the context of education refers to the systematic process of assessing the effectiveness of teaching, learning, and educational strategies. It involves gathering and analyzing data to determine how well students are learning, how effectively instructional methods are working, and how educational objectives are being met. In the pedagogy of biological science, evaluation helps educators refine their teaching practices, assess student progress, and improve the curriculum.

Types of Evaluation in Education

1. Formative Evaluation

- **Definition:** Ongoing evaluations conducted during the teaching-learning process.
- **Purpose:** To monitor student learning and provide feedback that can be used to improve instruction and learning in real-time.
- **Examples:**
 - Classroom quizzes
 - Group discussions
 - Short feedback forms
 - Student reflections
- **Benefits:** Helps teachers adjust their teaching methods, address student misconceptions early, and guide students toward achieving learning goals.

2. Summative Evaluation

- **Definition:** Evaluation conducted at the end of a unit, course, or program to assess the overall effectiveness and achievement.
- **Purpose:** To evaluate student learning at the conclusion of an instructional period and to determine if the learning objectives were met.
- **Examples:**
 - Final exams
 - End-of-term projects
 - Standardized tests
 - Cumulative reports
- **Benefits:** Provides a comprehensive measure of student performance and curriculum effectiveness. Summative evaluations often inform grades and certifications.

3. Diagnostic Evaluation

- **Definition:** Pre-assessment conducted before instruction begins to understand students' prior knowledge and identify learning needs.
- **Purpose:** To identify strengths, weaknesses, and areas for improvement before the learning process starts.

CHAPTER 7

The Commerce and Accountancy Teacher

Prof. R. VAISHNAVI

Assistant Professor, School of Education, PRIST Deemed to be University, Thanjavur

The role of a commerce and accountancy teacher is pivotal in shaping students' understanding of business principles and financial management. Here's a detailed overview of the responsibilities, skills, and qualities that define an effective teacher in this field:

Roles and Responsibilities

- 1. Curriculum Design and Implementation**
 - Develop a comprehensive curriculum that aligns with educational standards and industry needs, covering essential topics like accounting, finance, marketing, and business law.
- 2. Instruction and Delivery**
 - Deliver engaging lessons using various teaching methods, including lectures, discussions, and hands-on activities, to facilitate student understanding and retention.
- 3. Assessment and Evaluation**
 - Create and administer assessments (quizzes, exams, projects) to evaluate student learning, providing timely and constructive feedback to guide improvement.
- 4. Classroom Management**
 - Foster a positive and inclusive classroom environment that encourages student participation and collaboration.
- 5. Professional Development**
 - Stay updated with trends in commerce and education through continuous learning, attending workshops, and networking with industry professionals.

Key Skills

- 1. Subject Matter Expertise**
 - Possess a deep understanding of commerce and accountancy principles, theories, and practices.
- 2. Effective Communication**
 - Clearly convey complex concepts and facilitate discussions, ensuring students comprehend the material.
- 3. Pedagogical Skills**
 - Utilize a variety of teaching methods to address different learning styles and engage students actively.
- 4. Analytical Skills**
 - Analyze student performance data to inform instructional decisions and improve teaching strategies.
- 5. Technological Proficiency**

CHAPTER 8

Planning for Instruction Prof. T. SELVARAJ

Assistant Professor, School of Education, PRIST Deemed to be University, Thanjavur

Planning for instruction is a vital component of effective teaching, as it involves organizing and designing lessons to meet learning objectives, address student needs, and ensure that the content is delivered effectively. In the context of biological science, instructional planning focuses on how to best teach scientific concepts, theories, and skills, ensuring that students can not only understand the material but also apply it to real-world scenarios.

Key Steps in Planning for Instruction

1. Define Learning Objectives

- **Purpose:** Clear learning objectives outline what students should know, understand, and be able to do by the end of the lesson or unit.
- **Examples:**
 - "Students will be able to explain the process of photosynthesis."
 - "Students will analyze the role of natural selection in evolution."
- **SMART Criteria:** Learning objectives should be **S**pecific, **M**easurable, **A**chievable, **R**elevant, and **T**ime-bound to ensure clarity and focus.

2. Identify and Align Curriculum Standards

- **Purpose:** Instruction must align with national, state, or local curriculum standards to ensure consistency and comprehensiveness.
- **Examples:** For biology, this may include standards related to genetics, ecosystems, evolution, and cell biology.
- **Benefits:** Ensures that instruction covers essential content and skills, helping students meet academic expectations.

3. Understand Student Needs and Context

- **Purpose:** Tailoring instruction to meet the diverse needs of learners.
- **Considerations:**
 - **Learning styles:** Some students may be visual learners, while others prefer hands-on activities or verbal instruction.
 - **Prior knowledge:** Assessing what students already know helps guide the depth of instruction.
 - **Diverse learning needs:** Differentiating instruction for students with special needs, language barriers, or advanced abilities is essential.
- **Examples:** Using models and diagrams for visual learners, or incorporating group activities for kinesthetic learners.

4. Select and Organize Content

- **Purpose:** Identify the key concepts, facts, and skills to be taught and decide the sequence in which they will be presented.
- **Examples:**

CHAPTER 9

Models

Prof. R. VAISHNAVI

Assistant Professor, School of Education, PRIST Deemed to be University, Thanjavur

In the context of education, "models" refer to structured frameworks or approaches that guide teaching and learning processes. Here are some prominent educational models that can be applied in teaching commerce and accountancy:

1. Direct Instruction Model

- **Description:** A teacher-centered approach where the instructor provides explicit teaching of concepts and skills.
- **Key Features:** Clear objectives, structured lessons, and systematic feedback.
- **Application:** Effective for teaching foundational accounting principles or economic theories.

2. Constructivist Model

- **Description:** Focuses on students actively constructing their own understanding through experiences and reflection.
- **Key Features:** Emphasis on inquiry, problem-solving, and collaboration.
- **Application:** Suitable for project-based learning, where students explore real-world business problems.

3. Cooperative Learning Model

- **Description:** Encourages students to work together in small groups to achieve learning goals.
- **Key Features:** Interdependence, individual accountability, and positive group dynamics.
- **Application:** Ideal for group projects in marketing or finance, fostering teamwork skills.

4. Problem-Based Learning (PBL) Model

- **Description:** Students learn through solving complex, real-world problems.
- **Key Features:** Self-directed learning, critical thinking, and collaboration.
- **Application:** Useful for analyzing case studies or developing business strategies.

5. Inquiry-Based Learning Model

- **Description:** Encourages students to ask questions and explore topics through research and investigation.
- **Key Features:** Open-ended questions, exploration, and student-led discussions.
- **Application:** Suitable for examining current market trends or ethical issues in business.

CHAPTER 10

Equipment and Resources for Teaching Commerce and Accountancy Prof. R. VAISHNAVI

Assistant Professor, School of Education, PRIST Deemed to be University, Thanjavur

Teaching commerce and accountancy effectively requires various equipment and resources to enhance the learning experience, engage students, and ensure the practical application of concepts. Below are essential tools and resources that can be utilized in the classroom:

1. Computers and Laptops

- **Purpose:** For teaching accounting software, preparing financial statements, analyzing data, and researching business trends.
- **Usage:** Students can use these devices to practice accounting tasks, run simulations, and prepare business projects using software like Excel, QuickBooks, and other accounting tools.

2. Accounting Software

- **Examples:** QuickBooks, Tally, SAP, Sage, Fresh Books.
- **Purpose:** To give students hands-on experience in managing financial records, bookkeeping, and accounting tasks.
- **Usage:** These tools allow students to simulate real-world accounting practices, such as creating balance sheets, income statements, and managing accounts payable/receivable.

3. Projectors and Smart Boards

- **Purpose:** For delivering visual presentations, lectures, and tutorials to the entire class.
- **Usage:** Teachers can project financial models, case studies, and presentations onto a screen to facilitate visual learning. Smart boards allow interactive sessions where students can engage directly with the material.

4. Textbooks and Reference Books

- **Purpose:** Serve as foundational resources for theory, principles, and examples in commerce and accounting.
- **Examples:**
 - "Financial Accounting" by Jerry J. Weygandt
 - "Principles of Accounting" by Warren, Reeve, and Duchac.
- **Usage:** These books provide theoretical concepts, solved examples, and exercises to practice. Reference books support in-depth understanding of advanced topics.

5. Financial Newspapers and Magazines



PEDAGOGY OF COMPUTER SCIENCE: PART - III

EDITED BY

T.SELVARAJ



978-93-6255-920-3

Pedagogy of Computer Science: Part - III
Copyright ©2023-2024 by Prof. T. Selvaraj

All rights reserved. No part of this book may be reproduced or transmitted in any form or by any means without written permission from the author.

ISBN:978-93-6255-920-3

Publisher: Ponnaiyah Ramajayam Institute of Science and Technology (PRIST)

TABLE OF CONTENTS

| | |
|---|-----|
| Introduction | 3 |
| CHAPTER 1 Nature and scope of Computer Science... .. | 16 |
| DR. R. GUNASEKARAN | |
| CHAPTER 2 Base of Computer Science in Education | 28 |
| Prof. T. SUBHASHINI | |
| CHAPTER 3 Exploring Learners and Methods of Teaching..... | 51 |
| Prof. R. VAISHNAVI | |
| CHAPTER 4 School Curriculum in Computer Science..... | 68 |
| Prof. T. SELVARAJ | |
| CHAPTER 5 Approaches and Strategies of Learning Computer Science | 85 |
| DR. R. GUNASEKARAN | |
| CHAPTER 6 Evaluation | 109 |
| DR. R. GUNASEKARAN | |
| CHAPTER 7 The Computer Science Teacher | 126 |
| DR. R. GUNASEKARAN | |
| CHAPTER 8 Planning for Instruction | 137 |
| Prof. T. SELVARAJ | |
| CHAPTER 9 Models of Teaching | 156 |
| Prof. R. VAISHNAVI | |
| CHAPTER 10 Equipment and Resources for Teaching Computer Science | 165 |
| DR. R. GUNASEKARAN | |
| REFERENCES..... | 170 |

CHAPTER I
Nature and scope of Computer Science
DR. R. GUNASEKARAN
Assistant professor, School of Education,
PRIST Deemed to Be University, Thanjavur.

The nature and scope of computer science encompass a broad range of topics, theories, and applications. Here's a detailed overview:

Nature of Computer Science

1. **Interdisciplinary Field:** Computer science integrates concepts from mathematics, engineering, and logic. It overlaps with fields like artificial intelligence, bioinformatics, and data science.
2. **Theoretical Foundations:** It involves the study of algorithms, data structures, computational theory, and the limits of computation (e.g., complexity theory, automata theory).
3. **Practical Applications:** Computer science is not just theoretical; it has real-world applications in software development, networking, cybersecurity, and more.
4. **Problem-Solving Focus:** The discipline emphasizes solving complex problems through computational thinking, which includes breaking down problems into manageable parts.
5. **Constantly Evolving:** As technology advances, computer science evolves rapidly, with emerging areas such as quantum computing, machine learning, and human-computer interaction.

Scope of Computer Science

1. **Software Development:** Involves designing, coding, testing, and maintaining software applications and systems.
2. **Algorithms and Data Structures:** Focuses on creating efficient algorithms and choosing the right data structures to solve problems effectively.
3. **Artificial Intelligence:** Encompasses machine learning, natural language processing, robotics, and computer vision, aiming to create systems that can perform tasks requiring human-like intelligence.
4. **Networking and Security:** Includes the study of computer networks, protocols, and cybersecurity measures to protect data and systems.
5. **Database Management:** Involves designing, implementing, and managing databases to store, retrieve, and manipulate data efficiently.
6. **Human-Computer Interaction (HCI):** Studies how people interact with computers and designs user-friendly interfaces and experiences.
7. **Web Development:** Covers the design and development of websites and web applications, including front-end and back-end technologies.
8. **Cloud Computing:** Focuses on the delivery of computing services over the internet, including storage, processing, and hosting.

CHAPTER 2
Base of Computer Science in Education
Prof. T. SUBHASHINI
Assistant professor, School of Education,
PRIST Deemed to Be University, Thanjavur.

The base of computer science in education is crucial for preparing students to navigate an increasingly digital world. Here are some key components:

Curriculum Design

1. **Foundational Knowledge:** Courses should introduce basic concepts such as algorithms, programming, data structures, and computer architecture.
2. **Integrated Approach:** Computer science should be integrated into other subjects, such as mathematics, science, and the arts, to highlight its interdisciplinary nature.
3. **Hands-On Learning:** Emphasizing project-based learning and practical applications helps students understand theoretical concepts through real-world scenarios.

Educational Standards

1. **Curriculum Frameworks:** Guidelines like the Computer Science Teachers Association (CSTA) and the International Society for Technology in Education (ISTE) provide standards for K-12 computer science education.
2. **Assessment Tools:** Development of assessments that measure not only knowledge but also practical skills and problem-solving abilities in computer science.

Teaching Methods

1. **Inquiry-Based Learning:** Encourages students to explore and ask questions, fostering a deeper understanding of computational thinking and problem-solving.
2. **Collaborative Projects:** Group work promotes teamwork and communication skills, essential in the tech industry.
3. **Flipped Classroom Models:** Allows students to learn at their own pace through online resources, reserving class time for hands-on activities and discussions.

Technology Integration

1. **Access to Resources:** Providing access to computers, software, and online platforms enables students to practice coding and explore computer science concepts.
2. **Educational Software:** Tools and platforms like Scratch, Code.org, and Tynker make learning programming fun and accessible for students of all ages.
3. **Virtual and Augmented Reality:** Using VR and AR can create immersive learning experiences, especially in fields like game design and simulation.

Professional Development for Educators

CHAPTER 3
Exploring Learners and Methods of Teaching
Prof. R. VAISHNAVI
Assistant professor, School of Education,
PRIST Deemed to Be University, Thanjavur.

That sounds interesting! Are you looking into specific teaching methods, types of learners, or how they interact? There are various approaches, like differentiated instruction, constructivist learning, and more.

- Lecture:** A traditional method where the teacher presents information, often to large groups. It's efficient for delivering content but may not engage all learners.
- Discussion:** Encourages students to engage with the material and each other, fostering critical thinking and deeper understanding.
- Cooperative Learning:** Students work in groups to solve problems or complete tasks, promoting collaboration and social skills.
- Project-Based Learning:** Students engage in projects that require them to apply knowledge and skills to real-world challenges, fostering creativity and problem-solving.
- Flipped Classroom:** Students learn new content at home (often via videos) and use class time for discussions, hands-on activities, or problem-solving.
- Inquiry-Based Learning:** Encourages students to ask questions and explore topics through investigation, fostering curiosity and deeper understanding.
- Direct Instruction:** A structured approach where the teacher provides explicit teaching of concepts and skills, often with guided practice.
- Experiential Learning:** Involves hands-on experiences, allowing students to learn through doing and reflecting on those experiences.

CHAPTER 4
School Curriculum in Computer Science
Prof. T. SELVARAJ
Assistant professor, School of Education,
PRIST Deemed to Be University, Thanjavur.

A well-structured school curriculum in computer science is essential for equipping students with the skills and knowledge they need in today's digital world. Here's a comprehensive outline for a K-12 computer science curriculum:

Elementary School (Grades K-5)

- 1. Introduction to Computer Science Concepts**
 - Basic computer hardware and software
 - Understanding the internet and online safety
 - Introduction to coding through visual programming (e.g., Scratch)
- 2. Computational Thinking**
 - Problem-solving strategies
 - Pattern recognition
 - Algorithms and sequences (simple programming concepts)
- 3. Digital Citizenship**
 - Responsible online behavior
 - Digital footprints
 - Cyberbullying awareness

Middle School (Grades 6-8)

- 1. Foundational Programming Skills**
 - Introduction to text-based programming languages (e.g., Python, JavaScript)
 - Basic algorithms and control structures (loops, conditionals)
- 2. Web Development**
 - HTML, CSS, and basic JavaScript
 - Creating simple web pages and projects
- 3. Data and Analysis**
 - Introduction to data types and structures
 - Basic data visualization techniques
 - Simple databases (e.g., spreadsheets)
- 4. Cybersecurity Basics**
 - Understanding online threats and protection strategies
 - Introduction to encryption and safe browsing practices
- 5. Project-Based Learning**
 - Collaborative projects that apply computer science concepts
 - Encourage creativity and problem-solving through design challenges

CHAPTER 5
Approaches and Strategies of Learning Computer Science
DR. R. GUNASEKARAN
Assistant professor, School of Education,
PRIST Deemed to Be University, Thanjavur.

learning computer science effectively requires a variety of approaches and strategies that cater to different learning styles and objectives. Here are some key methods:

1. Project-Based Learning

- **Description:** Students engage in real-world projects that require applying computer science concepts.
- **Benefits:** Encourages creativity, collaboration, and practical application of skills.
- **Example:** Developing a website or creating a simple app.

2. Inquiry-Based Learning

- **Description:** Students learn by asking questions, conducting research, and solving problems.
- **Benefits:** Fosters critical thinking and deeper understanding of concepts.
- **Example:** Investigating how algorithms work through experimentation and exploration.

3. Collaborative Learning

- **Description:** Students work in groups to tackle tasks, share knowledge, and learn from each other.
- **Benefits:** Enhances communication skills and promotes teamwork.
- **Example:** Pair programming or group projects.

4. Flipped Classroom

- **Description:** Students learn new content at home (via videos, readings) and apply that knowledge in class through exercises and projects.
- **Benefits:** Maximizes classroom time for hands-on learning and interaction.
- **Example:** Watching a lecture on programming concepts and then coding in class.

5. Gamification

- **Description:** Incorporating game elements (points, badges, levels) into the learning process.
- **Benefits:** Increases motivation and engagement.
- **Example:** Using platforms like CodeCombat or Codecademy that reward progress.

CHAPTER 6

Evaluation

DR. R. GUNASEKARAN
Assistant professor, School of Education,
PRIST Deemed to Be University, Thanjavur.

Evaluation in the context of education refers to the systematic process of assessing the effectiveness of teaching, learning, and educational strategies. It involves gathering and analyzing data to determine how well students are learning, how effectively instructional methods are working, and how educational objectives are being met. In the pedagogy of biological science, evaluation helps educators refine their teaching practices, assess student progress, and improve the curriculum.

Types of Evaluation in Education

1. Formative Evaluation

- **Definition:** Ongoing evaluations conducted during the teaching-learning process.
- **Purpose:** To monitor student learning and provide feedback that can be used to improve instruction and learning in real-time.
- **Examples:**
 - Classroom quizzes
 - Group discussions
 - Short feedback forms
 - Student reflections
- **Benefits:** Helps teachers adjust their teaching methods, address student misconceptions early, and guide students toward achieving learning goals.

2. Summative Evaluation

- **Definition:** Evaluation conducted at the end of a unit, course, or program to assess the overall effectiveness and achievement.
- **Purpose:** To evaluate student learning at the conclusion of an instructional period and to determine if the learning objectives were met.
- **Examples:**
 - Final exams
 - End-of-term projects
 - Standardized tests
 - Cumulative reports
- **Benefits:** Provides a comprehensive measure of student performance and curriculum effectiveness. Summative evaluations often inform grades and certifications.

3. Diagnostic Evaluation

- **Definition:** Pre-assessment conducted before instruction begins to understand students' prior knowledge and identify learning needs.
- **Purpose:** To identify strengths, weaknesses, and areas for improvement before the learning process starts.

CHAPTER 7

The Computer Science Teacher

DR. R. GUNASEKARAN

Assistant professor, School of Education,
PRIST Deemed to Be University, Thanjavur.

The role of a **Computer Science Teacher** is vital in shaping students' understanding of technology, programming, and computational thinking. They not only teach fundamental concepts but also inspire curiosity and creativity in students. Here's an overview of their responsibilities, qualities, and the challenges they face.

Key Responsibilities

1. Curriculum Development

- Design and implement a curriculum that aligns with educational standards and industry trends, covering topics such as programming languages, algorithms, data structures, software development, and cybersecurity.

2. Instructional Delivery

- Use a variety of teaching methods, including lectures, hands-on projects, and collaborative learning, to engage students with different learning styles.
- Integrate technology into lessons, using tools such as IDEs, simulation software, and online resources to enhance learning.

3. Assessment and Evaluation

- Create and administer assessments (quizzes, exams, projects) to evaluate student understanding and skills, providing constructive feedback to support improvement.
- Use formative assessments to monitor progress and adjust instruction as needed.

4. Facilitating Practical Experience

- Guide students through practical coding exercises, projects, and labs that allow them to apply theoretical concepts in real-world scenarios.
- Encourage participation in coding competitions, hackathons, and collaborative projects to foster teamwork and problem-solving skills.

5. Promoting Computational Thinking

- Teach students to approach problems methodically, breaking them down into smaller, manageable parts and using algorithms to devise solutions.
- Encourage critical thinking, creativity, and logical reasoning through coding challenges and project-based learning.

6. Mentorship and Support

- Provide guidance and mentorship to students interested in pursuing careers in technology, helping them explore opportunities and develop their skills.
- Create an inclusive classroom environment that supports diverse learners and encourages collaboration and peer support.

7. Professional Development

CHAPTER 8

Planning for Instruction

Prof. T. SELVARAJ

Assistant professor, School of Education,
PRIST Deemed to Be University, Thanjavur.

Planning for instruction is a vital component of effective teaching, as it involves organizing and designing lessons to meet learning objectives, address student needs, and ensure that the content is delivered effectively. In the context of biological science, instructional planning focuses on how to best teach scientific concepts, theories, and skills, ensuring that students can not only understand the material but also apply it to real-world scenarios.

Key Steps in Planning for Instruction

1. Define Learning Objectives

- **Purpose:** Clear learning objectives outline what students should know, understand, and be able to do by the end of the lesson or unit.
- **Examples:**
 - "Students will be able to explain the process of photosynthesis."
 - "Students will analyze the role of natural selection in evolution."
- **SMART Criteria:** Learning objectives should be **S**pecific, **M**easurable, **A**chievable, **R**elevant, and **T**ime-bound to ensure clarity and focus.

2. Identify and Align Curriculum Standards

- **Purpose:** Instruction must align with national, state, or local curriculum standards to ensure consistency and comprehensiveness.
- **Examples:** For biology, this may include standards related to genetics, ecosystems, evolution, and cell biology.
- **Benefits:** Ensures that instruction covers essential content and skills, helping students meet academic expectations.

3. Understand Student Needs and Context

- **Purpose:** Tailoring instruction to meet the diverse needs of learners.
- **Considerations:**
 - **Learning styles:** Some students may be visual learners, while others prefer hands-on activities or verbal instruction.
 - **Prior knowledge:** Assessing what students already know helps guide the depth of instruction.
 - **Diverse learning needs:** Differentiating instruction for students with special needs, language barriers, or advanced abilities is essential.
- **Examples:** Using models and diagrams for visual learners, or incorporating group activities for kinesthetic learners.

4. Select and Organize Content

- **Purpose:** Identify the key concepts, facts, and skills to be taught and decide the sequence in which they will be presented.

CHAPTER 9
Models of Teaching
Prof. R. VAISHNAVI
Assistant professor, School of Education,
PRIST Deemed to Be University, Thanjavur.

Models of teaching refer to structured, systematic approaches to instruction that help guide the teaching process to achieve specific learning outcomes. These models are based on theories of learning and development and provide educators with frameworks for organizing and delivering content, fostering student engagement, and promoting the effective acquisition of knowledge and skills. Each model emphasizes different aspects of learning and teaching, and the choice of model depends on the subject matter, learning objectives, and the needs of the students.

Here are some of the most widely recognized models of teaching:

1. The Direct Instruction Model

- **Definition:** A teacher-centered approach that emphasizes clear, structured, and explicit teaching of content or skills.
- **Key Features:**
 - Focus on mastery of content through systematic instruction.
 - The teacher leads the lesson by providing information, modeling, and giving guided practice.
 - Frequent feedback and correction are given to ensure understanding.
 - Lesson phases: Introduction, Presentation, Guided Practice, Independent Practice, and Closure.
- **Advantages:**
 - Highly effective for teaching foundational skills, especially in areas like math, reading, or basic biology concepts.
 - Structured and efficient, which makes it ideal for covering large amounts of content.
- **Disadvantages:**
 - Less emphasis on critical thinking and creativity.
 - Limits student autonomy and may not engage all learners.

Example in Biology: Teaching the structure of the cell by explaining and modeling the parts, providing guided practice through labeling exercises, and then assigning independent activities like cell diagram creation.

2. The Inquiry-Based Learning Model

- **Definition:** A student-centered approach that encourages students to ask questions, investigate problems, and discover answers through exploration.

CHAPTER 10

Equipment and Resources for Teaching Computer Science

DR. R. GUNASEKARAN

Assistant professor, School of Education,
PRIST Deemed to Be University, Thanjavur.

Teaching computer science effectively requires a variety of equipment and resources. Here's a comprehensive list to help educators create an engaging learning environment:

Equipment

1. Computers and Laptops

- Essential for coding, research, and running software applications.
- Ensure adequate specifications to handle programming environments and simulations.

2. Projectors and Smartboards

- Useful for displaying presentations, tutorials, and interactive lessons.
- Facilitates group discussions and collaborative coding.

3. Robots and Kits

- Educational robotics kits (e.g., LEGO Mindstorms, VEX Robotics) for hands-on learning.
- Introduces concepts in programming and engineering.

4. Microcontrollers and Development Boards

- Boards like Arduino or Raspberry Pi for projects involving hardware and software integration.
- Ideal for teaching concepts in electronics and IoT (Internet of Things).

5. Networking Equipment

- Routers, switches, and cables for teaching networking concepts.
- Enables students to set up and troubleshoot networks.

6. Virtual Reality (VR) and Augmented Reality (AR) Tools

- Equipment for immersive learning experiences in programming and game design.
- Tools like Oculus Rift or AR kits for interactive applications.

7. Digital Whiteboards and Annotation Tools

- Allows for collaborative coding and note-taking during lessons.
- Tools like Jam board or Miro for brainstorming and project planning.

Software and Online Resources

1. Integrated Development Environments (IDEs)

- Software like Visual Studio Code, PyCharm, or Eclipse for coding in various languages.
- Supports debugging and project management.

2. Version Control Systems

- Tools like Git and GitHub for teaching collaboration and code management.



MICROBES IN WASTE WATER

EDITED BY

DR.N.MAHALAKSHIMI



978-93-6255-072-9

Dr.N.MAHALAKSHIMI

Microbes in Wastewater

Copyright©2023 by **Dr.N.MAHALAKSHIMI**

All rights reserved. No part of this book may be reproduced or transmitted in any form or by any means without written permission from the author.

ISBN: 978-93-6255-072-9

Publisher: Ponnaiyah Ramajayam Institute of Science and Technology (PRIST)

TABLE OF CONTENTS

| | |
|--|-----|
| Introduction..... | 8 |
| Chapter I :Introduction to wastewater microbiology | 20 |
| DR.N.MAHALAKSHIMI | |
| Chapter II : Microbial Roles in Wastewater Treatment Processes | 26 |
| DR.S.MOHANRAJ | |
| Chapter III: Activated Sludge Process | 34 |
| DR. K. SUNDAR | |
| Chapter IV : Anaerobic Wastewater Treatment..... | 46 |
| DR. T.USHADEVI | |
| Chapter V: Biofilms in Wastewater Treatment..... | 53 |
| DR.R.SATHYA | |
| Chapter VI: Microbes in Nutrient Removal..... | 64 |
| DR.T.THIRUSELVI | |
| Chapter VII: Pathogens and Public Health Concerns..... | 77 |
| DR.A.XAVIER FERNANDES | |
| Chapter VIII : Emerging Contaminants and Microbial Degradation..... | 99 |
| DR.G. CHANDIRASEGARAN | |
| Chapter Ix : Advances in Wastewater Microbial Biotechnology..... | 120 |
| DR.K.P.KARUPPAIAH | |
| Chapter X Environmental and Regulatory Aspects | 132 |
| DR.AMBIKA K | |
| REFERENCES..... | 150 |

CHAPTER I

INTRODUCTION TO WASTEWATER MICROBIOLOGY

Dr.N.MAHALAKSHIMI

Professor, Department of Microbiology, School of Arts and Science, Ponnaiyah Ramajeyam Institute of Science and technology, Tamilnadu, India

Wastewater microbiology is a specialized field that focuses on the study of microorganisms involved in the treatment of wastewater. As urbanization and industrial activities generate increasing volumes of wastewater, understanding the microbial communities that inhabit these environments has become crucial. Microbes, including bacteria, archaea, fungi, and protozoa, play essential roles in breaking down organic matter and removing pollutants, transforming contaminated water into a resource that can be safely returned to the environment or reused.

The process of wastewater treatment relies heavily on the natural abilities of these microorganisms to metabolize various compounds. In aerobic processes, bacteria utilize oxygen to decompose organic materials, while anaerobic bacteria thrive in oxygen-poor environments, often producing methane as a byproduct. The diversity of microbial species and their metabolic pathways is vital for effective treatment, as different microbes are adept at targeting specific types of pollutants. By fostering a balanced and robust microbial community, wastewater treatment facilities can enhance their efficiency and improve the quality of treated effluent.

As research in wastewater microbiology advances, new technologies and methods are being developed to optimize microbial performance. Innovations such as bioaugmentation and biostimulation aim to enhance the natural processes of wastewater treatment by introducing beneficial microbes or providing nutrients that promote microbial growth. Additionally, molecular techniques allow for a deeper understanding of microbial interactions and community dynamics. As the challenges of water scarcity and pollution continue to rise, wastewater microbiology is poised to play a critical role in sustainable water management practices, ensuring that we can effectively treat wastewater while recovering valuable resources.

CHAPTER II

MICROBIAL ROLES IN WASTEWATER TREATMENT PROCESSES

DR.S.MOHANRAJ

Associate professor, Department of Microbiology, School of Arts and Science, Ponnaiyah Ramajeyam Institute of Science and technology, Tamilnadu, India

Microbial roles in wastewater treatment are fundamental to the efficient processing of organic and inorganic pollutants. The treatment process generally comprises three main stages: primary, secondary, and tertiary treatment, each relying on specific microbial communities. In the primary treatment phase, physical processes remove large solids from wastewater, but microbial activity begins even at this stage. As organic matter settles, bacteria and other microorganisms initiate the decomposition of these materials. This biological action reduces the overall organic load, facilitating better efficiency in subsequent treatment phases. Moreover, microbial processes in this initial stage help mitigate foul odors and improve the overall characteristics of the wastewater, preparing it for more intensive treatment.

The secondary treatment phase heavily relies on a diverse array of microorganisms to further break down the organic matter that remains after primary treatment. This stage typically employs aerobic and anaerobic processes, often within systems like activated sludge, trickling filters, or biofilm reactors. Aerobic bacteria, which require oxygen, thrive in aerated environments, effectively oxidizing organic pollutants into simpler compounds, primarily carbon dioxide and water. This conversion not only decreases the biological oxygen demand (BOD) of the wastewater but also helps in producing biomass, which can be further processed. Conversely, anaerobic bacteria play a crucial role in the digestion of sludge in low-oxygen conditions. These bacteria break down complex organic substances, generating biogas, a mixture of methane and carbon dioxide, which can be captured and utilized as a renewable energy source. The synergy between these microbial populations is vital, as they work together to ensure the complete breakdown of organic materials while minimizing the volume of residual sludge.

CHAPTER III

ACTIVATED SLUDGE PROCESS

DR. K. SUNDAR

Associate professor, Department of Microbiology, School of Arts and Science, Ponnaiyah Ramajeyam Institute of Science and technology, Tamilnadu, India

The Activated Sludge Process is a widely used method for treating wastewater that leverages microorganisms to break down organic matter. In this process, wastewater is aerated to promote the growth of bacteria and other microorganisms. The mixture of wastewater and activated sludge is aerated in a tank, allowing microorganisms to metabolize the organic pollutants. After aeration, the mixture moves to a settling tank, where the biomass separates from the treated water. The settled sludge can be partially recycled back to the aeration tank to maintain an optimal microbial population, while the treated effluent can be further processed or discharged.

One of the primary advantages of the Activated Sludge Process is its efficiency in reducing biochemical oxygen demand (BOD) and suspended solids, making it suitable for both municipal and industrial applications. The process can also be adapted to enhance nutrient removal, particularly nitrogen and phosphorus, through variations such as Enhanced Biological Phosphorus Removal (EBPR) and the Modified Ludzack-Ettinger process. These adaptations are increasingly important due to environmental regulations aimed at preventing eutrophication in receiving water bodies. Moreover, the process is relatively straightforward to operate, relying on careful monitoring and control of parameters like dissolved oxygen levels and sludge age.

Despite its advantages, the Activated Sludge Process faces challenges such as filamentous bulking, which can impair settling and effluent quality, and the management of excess sludge production, which incurs additional costs. Innovations like membrane bioreactors (MBRs) and anaerobic digestion are being explored to enhance treatment efficiency and sustainability. Overall, the Activated Sludge Process remains a fundamental approach in wastewater management, continually evolving with technological advancements to meet growing environmental challenges.

CHAPTER IV

ANAEROBIC WASTEWATER TREATMENT

DR. T.USHADEVI

Assistant professor, Department of Microbiology, School of Arts and Science, Ponnaiyah Ramajeyam Institute of Science and technology, Tamilnadu, India

Anaerobic wastewater treatment is a biological process that occurs in the absence of oxygen, utilizing microorganisms to break down organic matter. This method is particularly effective for high-strength wastewater, such as that from industrial processes or agricultural operations. In anaerobic systems, organic materials are converted into biogas—primarily methane and carbon dioxide—which can be captured and used as a renewable energy source. The residual digestate can also be used as a nutrient-rich fertilizer, making this approach both sustainable and economically beneficial.

One of the ultimate advantages of anaerobic treatment is its lower energy consumption compared to aerobic processes, as it does not require aeration. Additionally, it reduces the volume of sludge produced, minimizing disposal challenges. This process can be implemented in various configurations, including anaerobic lagoons, upflow anaerobic sludge blanket (UASB) reactors, and anaerobic membrane bioreactors (AnMBRs). These systems can be tailored to meet specific treatment needs and operational conditions, providing flexibility in design and application.

Despite its benefits, anaerobic wastewater treatment does present challenges, such as the need for stable operational conditions to prevent process disruptions and the potential for longer retention times. Effective management of temperature, pH, and loading rates is crucial for optimizing microbial activity and biogas production. Moreover, pretreatment may be necessary for certain waste types to enhance biodegradability. As innovations continue to emerge, anaerobic treatment is gaining traction as a viable solution for sustainable wastewater management in various sectors.

CHAPTER V

BIOFILMS IN WASTEWATER TREATMENT

DR.R.SATHYA

Assistant professor, Department of Microbiology, School of Arts and Science, Ponnaiyah Ramajeyam Institute of Science and technology, Tamilnadu, India

Biofilms play a crucial role in wastewater treatment processes by providing a surface for microbial communities to attach and grow, facilitating the breakdown of organic matter and pollutants. These complex structures, composed of microorganisms embedded in a matrix of extracellular polymeric substances, enhance the efficiency of biological treatment systems such as trickling filters, rotating biological contactors, and membrane bioreactors. As water flows over or through the biofilm, microorganisms metabolize organic compounds, leading to significant reductions in biochemical oxygen demand (BOD) and suspended solids in the effluent.

One of the key advantages of biofilm-based treatment systems is their ability to maintain high microbial densities, which can improve treatment performance and resilience. Biofilms can also adapt to varying wastewater compositions and conditions, making them suitable for diverse applications, including industrial effluent treatment and nutrient removal. Furthermore, the reduced hydraulic retention time in biofilm systems can lead to smaller reactor sizes and lower operational costs compared to conventional activated sludge systems.

However, managing biofilm development presents challenges, such as controlling thickness and preventing sloughing, which can lead to fluctuations in treatment efficiency. Optimal environmental conditions, including nutrient availability and shear forces, are essential for promoting healthy biofilm growth. Additionally, monitoring and maintaining biofilm health require careful management to ensure the long-term stability and performance of wastewater treatment systems. As research advances, biofilms are being increasingly integrated into innovative treatment approaches, highlighting their significance in achieving sustainable wastewater management.

CHAPTER VI

MICROBES IN NUTRIENT REMOVAL

DR.T.THIRUSELVI

Assistant professor, Department of Microbiology, School of Arts and Science, Ponnaiyah Ramajeyam Institute of Science and technology, Tamilnadu, India

Microbes play a crucial role in the removal of nutrients from wastewater, particularly nitrogen and phosphorus, which can lead to environmental issues like eutrophication if not managed properly. In wastewater treatment systems, diverse microbial communities, including bacteria, archaea, and fungi, work together to convert these nutrients into less harmful forms. For instance, nitrifying bacteria oxidize ammonia to nitrite and then to nitrate, while denitrifying bacteria further reduce nitrate to nitrogen gas, effectively removing excess nitrogen from the system.

Phosphorus removal is often achieved through a combination of biological and chemical processes. Certain bacteria, such as those in the genus **Candidatus Accumulibacter**, can uptake and store phosphorus in their cells, a process known as enhanced biological phosphorus removal (EBPR). These microbes accumulate phosphorus in the form of polyphosphate granules during the anaerobic phase of treatment and release it during the aerobic phase, allowing for its subsequent removal from the wastewater. This biological approach is not only effective but also cost-efficient compared to traditional chemical treatments.

The synergy between various microbial processes is vital for optimizing nutrient removal in wastewater treatment plants. By maintaining conditions that promote the growth of specific microbial populations, such as controlling oxygen levels and carbon sources, treatment facilities can enhance the efficiency of nutrient removal. The ongoing research into microbial interactions and the development of bioaugmentation strategies further improve our understanding of these complex systems, paving the way for more sustainable and effective wastewater management practices.

CHAPTER VII

PATHOGENS AND PUBLIC HEALTH CONCERNS

DR.A.XAVIER FERNANDES

Assistant professor, Department of Microbiology, School of Arts and Science, Ponnaiyah Ramajeyam Institute of Science and technology, Tamilnadu, India

Pathogens present in wastewater pose significant public health concerns, as untreated or inadequately treated effluent can contaminate water sources and spread infectious diseases. Wastewater can harbor a variety of microorganisms, including bacteria, viruses, protozoa, and helminths, many of which are pathogenic to humans. Common pathogens such as *Escherichia coli*, *Salmonella*, and *Giardia* can lead to gastrointestinal illnesses and other serious health issues. This risk emphasizes the importance of effective wastewater treatment processes to reduce pathogen loads before effluent is released into the environment or reused.

To mitigate public health risks, wastewater treatment facilities employ various methods to inactivate or remove pathogens. These methods include biological treatment processes, disinfection techniques (such as chlorination, ultraviolet (UV) light, and ozonation), and advanced filtration systems. Each method has its advantages and limitations; for instance, while chlorination is effective against many bacteria and viruses, it may not eliminate all protozoan cysts. Therefore, a multi-barrier approach is often recommended to ensure comprehensive pathogen control and enhance the safety of treated wastewater.

Continuous monitoring and regulation are crucial in addressing pathogens in wastewater treatment. Public health guidelines and standards set by organizations such as the World Health Organization (WHO) and the Environmental Protection Agency (EPA) help ensure that treatment facilities meet safety criteria. Moreover, ongoing research into the dynamics of pathogen survival and resistance in wastewater environments is essential for developing more effective treatment strategies. As water reuse and recycling become increasingly important in addressing water scarcity, ensuring the microbiological safety of wastewater remains a top priority for public health protection.

CHAPTER VIII

EMERGING CONTAMINANTS AND MICROBIAL DEGRADATION DR.G. CHANDIRASEGARAN

Assistant professor, Department of Microbiology, School of Arts and Science, Ponnaiyah Ramajeyam Institute of Science and technology, Tamilnadu, India

Emerging contaminants, including pharmaceuticals, personal care products, and industrial chemicals, are increasingly recognized as significant pollutants in wastewater. These compounds often escape conventional treatment processes, leading to their accumulation in aquatic environments and potential harm to ecosystems and human health. Unlike traditional contaminants, emerging pollutants can be persistent and may exhibit complex chemical structures that make them resistant to microbial degradation. As awareness of these substances grows, there is a pressing need to understand how wastewater treatment systems can effectively address them.

Microbial degradation plays a crucial role in the removal of emerging contaminants from wastewater. Various microorganisms possess the ability to metabolize or transform these compounds, breaking them down into less harmful substances. Research has shown that certain bacteria and fungi can degrade pharmaceuticals and other organic pollutants through specific enzymatic pathways. For instance, some bacteria have developed the capacity to utilize these compounds as carbon and energy sources, while others may co-metabolize them in the presence of more readily degradable substrates. This microbial versatility offers promising avenues for enhancing the efficiency of wastewater treatment processes in removing emerging contaminants.

To optimize microbial degradation of emerging pollutants, factors such as temperature, pH, and nutrient availability must be carefully managed within treatment systems. Innovations in bioreactor design, such as the incorporation of bioaugmentation and biostimulation strategies, can enhance the microbial communities' ability to degrade these contaminants. Additionally, ongoing research into the genetics and enzymatic pathways of degrading microorganisms is vital for developing targeted bioremediation approaches. As regulations around emerging contaminants become stricter, advancing our understanding of microbial degradation processes will be essential for ensuring the safety and sustainability of wastewater treatment and protecting public health and the environment.

CHAPTER IX

ADVANCES IN WASTEWATER MICROBIAL BIOTECHNOLOGY

DR.K.P.KARUPPAIAH

Assistant professor, Department of Microbiology, School of Arts and Science, Ponnaiyah Ramajeyam Institute of Science and technology, Tamilnadu, India

Advances in wastewater microbial biotechnology are revolutionizing the way we treat wastewater and manage pollutants. Innovations such as molecular techniques, including metagenomics and next-generation sequencing, have enhanced our understanding of the complex microbial communities present in wastewater treatment systems. These technologies allow researchers to identify and characterize the diverse range of microorganisms that contribute to pollutant degradation and nutrient removal. By elucidating the functional capabilities of these microbial communities, we can optimize treatment processes and develop tailored approaches to address specific contaminants more effectively.

One significant advancement is the application of bioaugmentation and biostimulation strategies, which involve the addition of specific microorganisms or nutrients to enhance the degradation of pollutants. For instance, engineered microbial strains with enhanced metabolic pathways are being developed to target emerging contaminants such as pharmaceuticals and personal care products. Additionally, the use of microbial consortia—groups of synergistic microorganisms—can improve overall treatment efficiency by facilitating complex biodegradation pathways and improving the resilience of treatment systems. These strategies not only increase the rate of pollutant removal but also contribute to the sustainability of wastewater treatment processes.

Another notable trend is the integration of biotechnology with advanced treatment technologies, such as membrane bioreactors (MBRs) and anaerobic digestion systems. These combined approaches enhance the removal of both organic and inorganic pollutants while enabling energy recovery through biogas production. Moreover, innovations such as bioremediation techniques that leverage natural microbial processes for environmental cleanup are gaining traction. As the field of wastewater microbial biotechnology continues to evolve, these advances will play a

CHAPTER X

ENVIRONMENTAL AND REGULATORY ASPECTS

DR.AMBIKA K

Assistant professor, Department of Microbiology, School of Arts and Science, Ponnaiyah Ramajeyam Institute of Science and technology, Tamilnadu, India

Environmental and regulatory aspects are critical in shaping the role of microbes in wastewater treatment, as these factors help ensure that treatment processes effectively reduce pollutants while safeguarding public health and ecosystems. Regulatory frameworks set by organizations such as the Environmental Protection Agency (EPA) and the World Health Organization (WHO) establish standards for effluent quality, which include permissible levels of pathogens, nutrients, and emerging contaminants. These regulations influence the design and operation of wastewater treatment facilities, requiring the integration of effective microbial processes that can meet stringent performance criteria.

The environmental impact of wastewater treatment practices is another key consideration, as microbial processes can have both beneficial and detrimental effects on ecosystems. Effective treatment reduces the discharge of harmful substances into waterways, thereby protecting aquatic life and improving water quality. However, the release of treated effluent containing residual contaminants or antibiotic-resistant microorganisms can pose risks to both human and environmental health. Therefore, continuous monitoring and assessment of microbial communities within treatment systems are essential to ensure that they not only meet regulatory standards but also promote ecological balance.

Emerging trends in environmental regulations are increasingly emphasizing the need for sustainable wastewater management practices that incorporate microbial biotechnology. This includes a focus on resource recovery, such as the generation of biogas from anaerobic digestion and the recovery of nutrients like nitrogen and phosphorus for reuse in agriculture. As regulations evolve, there is a growing recognition of the importance of integrating microbial processes with circular economy principles, fostering the development of innovative treatment technologies. Ultimately, a comprehensive understanding of the environmental and regulatory landscape is essential for advancing microbial applications in wastewater treatment while promoting sustainable practices that protect public health and the environment.



BIOFERTILIZERS



EDITED BY

DR. A. XAVIER FERNANDES



978-93-6255-136-8

Biofertilizers

Copyright©2023 by **DR. K.KOILDASAN MANOHARAN**

All rights reserved. No part of this book may be reproduced or transmitted in any form or by any means without written permission from the author.

ISBN: 978-93-6255-136-8

Publisher: Ponnaiyah Ramajayam Institute of Science and Technology (PRIST)

TABLE OF CONTENTS

| | |
|--|-----|
| Introduction..... | 8 |
| Chapter I :Introduction to Biofertilizers..... | 20 |
| Dr. S. RAMESH | |
| Chapter II : Nitrogen-Fixing Biofertilizers..... | 26 |
| DR.S.MOHANRAJ | |
| Chapter III: Phosphate-Solubilizing Microorganisms..... | 34 |
| DR. K. SUNDAR | |
| Chapter IV : Potassium and Zinc-Solubilizing Biofertilizers..... | 46 |
| DR. T.USHADEVI | |
| Chapter V: Mycorrhizal Biofertilizers..... | 53 |
| DR.R.SATHYA | |
| Chapter VI: Plant Growth-Promoting Rhizobacteria (PGPR)..... | 64 |
| DR.T.THIRUSELVI | |
| Chapter VII:Organic Matter Decomposers and Composting Microorganisms | 77 |
| DR.A.XAVIER FERNANDES | |
| Chapter VIII : Commercial Production of Biofertilizers..... | 99 |
| DR.G. CHANDIRASEGARAN | |
| Chapter Ix : Application Methods and Field Practices..... | 120 |
| DR.K.P.KARUPPAIAN | |
| Chapter X Challenges and Future Perspectives in Biofertilizer Technology | 132 |
| DR.AMBIKA K | |
| REFERENCES..... | 150 |

CHAPTER I

INTRODUCTION TO BIOFERTILIZERS

Dr. S. RAMESH

Professor, Department of Microbiology, School of Arts and Science, Ponnaiyah Ramajeyam Institute of Science and technology, Tamilnadu, India

Biofertilizers are an innovative and sustainable alternative to chemical fertilizers, harnessing natural processes to enhance soil fertility and promote plant growth. Derived from living organisms, such as bacteria, fungi, and algae, biofertilizers work synergistically with the plant's root system to improve nutrient availability and uptake. They play a crucial role in promoting soil health, boosting biodiversity, and reducing dependence on synthetic inputs, which can have harmful environmental impacts.

The use of biofertilizers is rooted in the understanding of plant-microbe interactions, where beneficial microorganisms help in nitrogen fixation, phosphorus solubilization, and the degradation of organic matter. By establishing a thriving microbial community in the soil, biofertilizers contribute to the natural nutrient cycle, enhancing soil structure and fertility over time. This ecological approach not only increases crop yield but also supports sustainable agricultural practices that protect ecosystems and improve food security.

As the demand for sustainable agricultural practices grows, biofertilizers are gaining popularity among farmers and researchers alike. Their ability to mitigate soil degradation, improve resilience against pests and diseases, and reduce greenhouse gas emissions makes them a vital component of modern farming. Ongoing research and development in this field continue to expand our understanding of these biological products, paving the way for more efficient and environmentally friendly agricultural solutions.

CHAPTER II

NITROGEN-FIXING BIOFERTILIZERS

DR.S.MOHANRAJ

Associate professor, Department of Microbiology, School of Arts and Science, Ponnaiyah Ramajeyam Institute of Science and technology, Tamilnadu, India

Nitrogen-fixing biofertilizers are crucial components of sustainable agriculture, particularly in enhancing soil fertility and promoting crop growth. These biofertilizers contain microorganisms, such as Rhizobium, Azotobacter, and Frankia, that can convert atmospheric nitrogen into forms usable by plants. This natural process, known as nitrogen fixation, significantly reduces the need for synthetic nitrogen fertilizers, which can lead to soil degradation and water pollution. By utilizing nitrogen-fixing biofertilizers, farmers can improve soil health while also promoting eco-friendly farming practices.

The mechanism of nitrogen fixation involves symbiotic relationships between these microorganisms and specific plants, particularly legumes. When plants form root nodules with Rhizobium, they provide a habitat for the bacteria, which in turn supply the plants with essential nitrogen compounds. This partnership not only enhances nutrient availability but also improves plant resilience against environmental stresses. As a result, crops grown with nitrogen-fixing biofertilizers often exhibit increased yield and quality, benefiting both farmers and consumers.

Furthermore, the use of nitrogen-fixing biofertilizers contributes to broader environmental sustainability goals. By reducing reliance on chemical fertilizers, these biofertilizers help minimize the adverse effects associated with their overuse, such as soil acidification and eutrophication of water bodies. Additionally, they promote biodiversity by fostering beneficial microbial communities in the soil. As research continues to advance in this field, the potential for nitrogen-fixing biofertilizers to support sustainable agriculture and combat food insecurity becomes increasingly evident, making them an essential tool for the future of farming.

CHAPTER III
PHOSPHATE-SOLUBILIZING MICROORGANISMS

DR. K. SUNDAR

Associate professor, Department of Microbiology, School of Arts and Science, Ponnaiyah Ramajeyam Institute of Science and technology, Tamilnadu, India

Phosphate-solubilizing microorganisms (PSMs) are integral components of biofertilizers, playing a crucial role in improving soil fertility and enhancing plant growth. These microorganisms, including various bacteria and fungi, have the unique ability to convert insoluble forms of phosphorus into soluble ones, making them more accessible to plants. This process is essential because phosphorus is a vital nutrient for plant development, influencing root formation, flowering, and overall crop yield. By incorporating PSMs into biofertilizers, farmers can optimize phosphorus availability, thereby supporting healthier and more productive crops.

The mechanisms by which phosphate-solubilizing microorganisms operate are varied and complex. They typically produce organic acids, enzymes, and other metabolites that dissolve phosphorus from mineral sources. For instance, some bacteria lower soil pH through acid production, which helps liberate bound phosphorus. Additionally, mycorrhizal fungi form symbiotic relationships with plant roots, enhancing nutrient uptake, particularly phosphorus. This synergy not only improves nutrient absorption but also fosters stronger root systems, leading to increased resilience against environmental stressors and better overall plant health.

Utilizing PSMs in biofertilizers aligns with sustainable agricultural practices by reducing the dependence on chemical fertilizers, which can contribute to soil degradation and water pollution. By promoting natural phosphorus solubilization, these biofertilizers help maintain ecological balance and enhance soil biodiversity. As research into PSMs continues to evolve, their integration into biofertilizer formulations holds great promise for sustainable farming, improving crop productivity while minimizing environmental impact. This innovative approach supports the goal of achieving food security in an eco-friendly manner, making PSMs essential players in modern agriculture.

CHAPTER IV

POTASSIUM AND ZINC-SOLUBILIZING BIOFERTILIZERS

DR. T.USHADEVI

Assistant professor, Department of Microbiology, School of Arts and Science, Ponnaiyah Ramajeyam Institute of Science and technology, Tamilnadu, India

Potassium- and zinc-solubilizing biofertilizers play a crucial role in enhancing nutrient availability in soils, promoting sustainable agricultural practices. These biofertilizers contain beneficial microorganisms, such as certain strains of *Bacillus* and *Pseudomonas*, that can solubilize potassium and zinc compounds present in the soil, converting them into forms that are more easily absorbed by plants. This natural process reduces the need for chemical fertilizers, which can have long-term negative effects on soil health and the environment.

By improving the availability of potassium and zinc, these biofertilizers enhance plant growth and development. Potassium is vital for regulating water balance, enzyme activation, and photosynthesis in plants, while zinc plays a crucial role in protein synthesis, hormone regulation, and the formation of chlorophyll. The deficiency of these nutrients can severely impact crop yields and quality, making their solubilization an essential factor for improving agricultural productivity.

Incorporating potassium- and zinc-solubilizing biofertilizers into farming practices promotes sustainable soil management, reduces dependency on synthetic fertilizers, and supports long-term soil fertility. This approach aligns with global efforts to encourage eco-friendly agriculture and mitigate the environmental impact of intensive farming.

CHAPTER V

MYCORRHIZAL BIOFERTILIZERS

DR.R.SATHYA

Assistant professor, Department of Microbiology, School of Arts and Science, Ponnaiyah Ramajeyam Institute of Science and technology, Tamilnadu, India

Introduction to Mycorrhizal Biofertilizers:

Mycorrhizal biofertilizers represent a symbiotic relationship between fungi and plant roots, promoting enhanced nutrient uptake and plant growth. These biofertilizers contain beneficial mycorrhizal fungi, which colonize the roots and extend far into the soil through hyphal networks. This extended reach helps plants access nutrients like phosphorus, nitrogen, and essential micronutrients, which would otherwise be unavailable to them.

Agricultural Benefits:

Using mycorrhizal biofertilizers in agriculture offers significant advantages, including improved soil structure, increased drought resistance, and better crop yields. By enhancing the root system's surface area, these biofertilizers enable plants to thrive in nutrient-poor soils while reducing the need for chemical fertilizers. Additionally, they play a critical role in sustainable farming by promoting soil health and reducing environmental degradation caused by synthetic fertilizers.

Environmental and Economic Impact:

From an environmental standpoint, mycorrhizal biofertilizers contribute to the reduction of agricultural runoff, which can lead to waterway contamination and ecosystem damage. Economically, farmers benefit from reduced input costs for fertilizers and water, leading to more cost-effective and eco-friendly farming practices. The growing demand for organic produce has further highlighted the importance of using these biofertilizers as a sustainable alternative in modern agriculture.

CHAPTER VI

PLANT GROWTH-PROMOTING RHIZOBACTERIA (PGPR)

Dr.T.Thiruselvi

Plant Growth-Promoting Rhizobacteria (PGPR) are beneficial bacteria that colonize plant roots and enhance plant growth and health through various mechanisms. Here's a closer look at what they do:

Mechanisms of Action

1. **Nutrient Solubilization:** PGPR can solubilize essential nutrients, such as phosphorus and iron, making them more available to plants.
2. **Hormone Production:** Some PGPR produce phytohormones like auxins, gibberellins, and cytokinins, which promote root and shoot growth.
3. **Biocontrol:** PGPR can suppress plant pathogens through competition, the production of antibiotics, or inducing systemic resistance in plants.
4. **Nitrogen Fixation:** Certain PGPR, particularly those in the genus *Rhizobium*, can fix atmospheric nitrogen, providing an essential nutrient for plants.
5. **Stress Tolerance:** PGPR can help plants withstand abiotic stresses such as drought, salinity, and heavy metals by enhancing physiological responses.

Examples of PGPR

- ***Pseudomonas spp.***: Known for their ability to produce antibiotics and promote plant health.
- ***Bacillus spp.***: Capable of producing enzymes that can enhance nutrient availability and stimulate plant growth.
- ***Azospirillum spp.***: Effective in promoting root development and nitrogen fixation.

Applications

1. **Agricultural Practices:** Using PGPR as biofertilizers or biopesticides can reduce chemical inputs and promote sustainable farming.
2. **Soil Health:** PGPR contribute to soil fertility and structure, improving overall soil health.
3. **Crop Yield:** Many studies have shown that inoculating crops with PGPR can significantly increase yields.

Future Directions

Research continues to explore the diverse roles of PGPR in various ecosystems, their interactions with plants, and their potential in biotechnological applications, including genetic engineering and synthetic biology for enhanced plant traits.

Conclusion

PGPR play a crucial role in sustainable agriculture, offering a natural alternative to chemical fertilizers and pesticides. Their ability to promote plant growth and health makes them an exciting area of study in both microbiology and agronomy.

CHAPTER VII

ORGANIC MATTER DECOMPOSERS AND COMPOSTING MICROORGANISMS

Dr.A.XAVIER FERNANDES

Assistant professor, Department of Microbiology, School of Arts and Science, Ponnaiyah Ramajeyam Institute of Science and technology, Tamilnadu, India

Organic Matter Decomposers play a vital role in breaking down organic materials in ecosystems, facilitating nutrient recycling and soil health. These decomposers, primarily bacteria, fungi, and actinomycetes, work by converting complex organic substances such as plant residues, animal waste, and dead organisms into simpler compounds like carbon dioxide, water, and nutrients. This process enriches the soil with essential nutrients such as nitrogen and phosphorus, improving its structure and fertility. Without these decomposers, organic matter would accumulate, disrupting natural cycles and inhibiting plant growth.

In composting, a controlled version of organic matter decomposition, microorganisms are essential for transforming raw organic waste into nutrient-rich compost. Various microorganisms, including aerobic bacteria, thermophilic bacteria, and fungi, break down organic material at different stages of composting. Aerobic bacteria are particularly important at the beginning, rapidly digesting easily degradable compounds, while thermophilic bacteria thrive in higher temperatures, accelerating the breakdown of more resistant substances. Fungi help decompose tough organic materials like cellulose and lignin, ensuring that all components of the waste are processed.

The balance of these composting microorganisms is crucial for efficient compost production. Proper moisture, temperature, and oxygen levels create an optimal environment for microbial activity, leading to faster decomposition. When conditions are managed correctly, microorganisms convert organic waste into humus, a dark, rich material that can be used to enhance soil fertility, retain moisture, and support sustainable agriculture practices. By understanding and supporting the role of decomposers and composting microorganisms, we can contribute to healthier ecosystems and more sustainable waste management practices.

CHAPTER VIII

COMMERCIAL PRODUCTION OF BIOFERTILIZERS

Dr.G. CHANDIRASEGARAN

Assistant professor, Department of Microbiology, School of Arts and Science, Ponnaiyah Ramajeyam Institute of Science and technology, Tamilnadu, India

The commercial production of biofertilizers plays a crucial role in modern agriculture, as it helps enhance soil fertility and promote sustainable farming. Biofertilizers contain living microorganisms that naturally fix atmospheric nitrogen, solubilize phosphorus, and decompose organic matter, contributing to the nutrient cycle. Their production involves culturing beneficial microorganisms such as nitrogen-fixing bacteria (e.g., *Rhizobium*), phosphate-solubilizing bacteria, and mycorrhizal fungi under controlled conditions to maintain high quality and efficacy.

The production process begins with isolating and identifying efficient strains of microorganisms that have proven benefits for plant growth. These strains are mass-cultured in specialized fermenters, where the environment is optimized for their growth and multiplication. Once the desired microbial population is achieved, the culture is mixed with a carrier material like peat, vermiculite, or lignite to facilitate easy application and storage. Strict quality control measures, including sterility and microbial activity tests, are employed throughout the production process to ensure the biofertilizers are safe, effective, and long-lasting.

The demand for biofertilizers is steadily increasing due to the growing emphasis on organic farming and environmentally friendly agricultural practices. Commercial production not only meets this rising demand but also helps reduce the dependency on chemical fertilizers, contributing to healthier ecosystems and more sustainable food production.

CHAPTER IX

APPLICATION METHODS AND FIELD PRACTICES

Dr.K.P.KARUPPAIAN

Assistant professor, Department of Microbiology, School of Arts and Science, Ponnaiyah Ramajeyam Institute of Science and technology, Tamilnadu, India

Application Methods for Biofertilizers:

Biofertilizers can be applied using a variety of methods, depending on the crop type, soil conditions, and local agricultural practices. Seed treatment is a common method where seeds are coated with biofertilizers before sowing, ensuring that beneficial microorganisms are directly introduced to the seed environment. Another approach is soil treatment, where biofertilizers are incorporated into the soil to enhance nutrient availability. Foliar application, where biofertilizers are sprayed on the leaves, is also an effective method for crops needing additional nutrient support during their growth phase.

Field Practices for Biofertilizer Use:

To maximize the benefits of biofertilizers in the field, it is important to follow specific agricultural practices. This includes ensuring proper soil preparation through adequate tilling and moisture levels to support microbial activity. Crop rotation and intercropping with legumes can also enhance the effectiveness of biofertilizers by creating symbiotic relationships that boost nitrogen fixation. Additionally, maintaining appropriate organic matter in the soil supports microbial growth, leading to better long-term soil health and improved crop yields.

Sustainable Benefits of Biofertilizers in Agriculture:

Biofertilizers play a critical role in promoting sustainable agriculture by reducing the reliance on chemical fertilizers. They not only enhance plant growth by improving nutrient uptake but also contribute to long-term soil fertility by maintaining microbial diversity. The use of biofertilizers in combination with organic farming techniques has been shown to improve water retention, reduce soil erosion, and lower the carbon footprint of agricultural activities, making them an essential tool for eco-friendly farming.

CHAPTER X

CHALLENGES AND FUTURE PERSPECTIVES IN BIOFERTILIZER TECHNOLOGY

Dr.AMBIKA K

Assistant professor, Department of Microbiology, School of Arts and Science, Ponnaiyah Ramajeyam Institute of Science and technology, Tamilnadu, India

Challenges in Biofertilizer Technology

Biofertilizer technology faces several challenges that hinder its widespread adoption. One of the key issues is the lack of awareness and education among farmers regarding the benefits of biofertilizers over chemical alternatives. Additionally, the variability in the performance of biofertilizers due to environmental factors such as soil type, temperature, and moisture content further complicates their effective application. The limited shelf-life of biofertilizers, driven by the viability of living microorganisms, also poses storage and transportation challenges, making it difficult for them to reach remote agricultural regions.

Technological and Regulatory Constraints

From a technological perspective, the production of biofertilizers requires a high level of precision in culturing and maintaining specific strains of microorganisms, which can be costly and time-consuming. Moreover, the regulatory framework surrounding biofertilizer production is still evolving in many regions, often lacking the stringent quality control that is necessary to ensure consistent and effective products. This lack of regulatory standardization can lead to market fragmentation and the proliferation of substandard products, further deterring farmers from switching to biofertilizers.

Future Perspectives

Despite these challenges, the future of biofertilizer technology looks promising due to the growing global emphasis on sustainable agriculture and the reduction of chemical inputs. Advances in biotechnology and microbial research are expected to produce more robust strains of microorganisms that are better suited to diverse environmental conditions. Furthermore, improved formulations and delivery mechanisms, such as encapsulation techniques, could extend the shelf-life and efficacy of biofertilizers.



AGRICULTURAL AND ENVIRONMENTAL MICROBIOLOGY

EDITED BY

DR.R.SATHYA

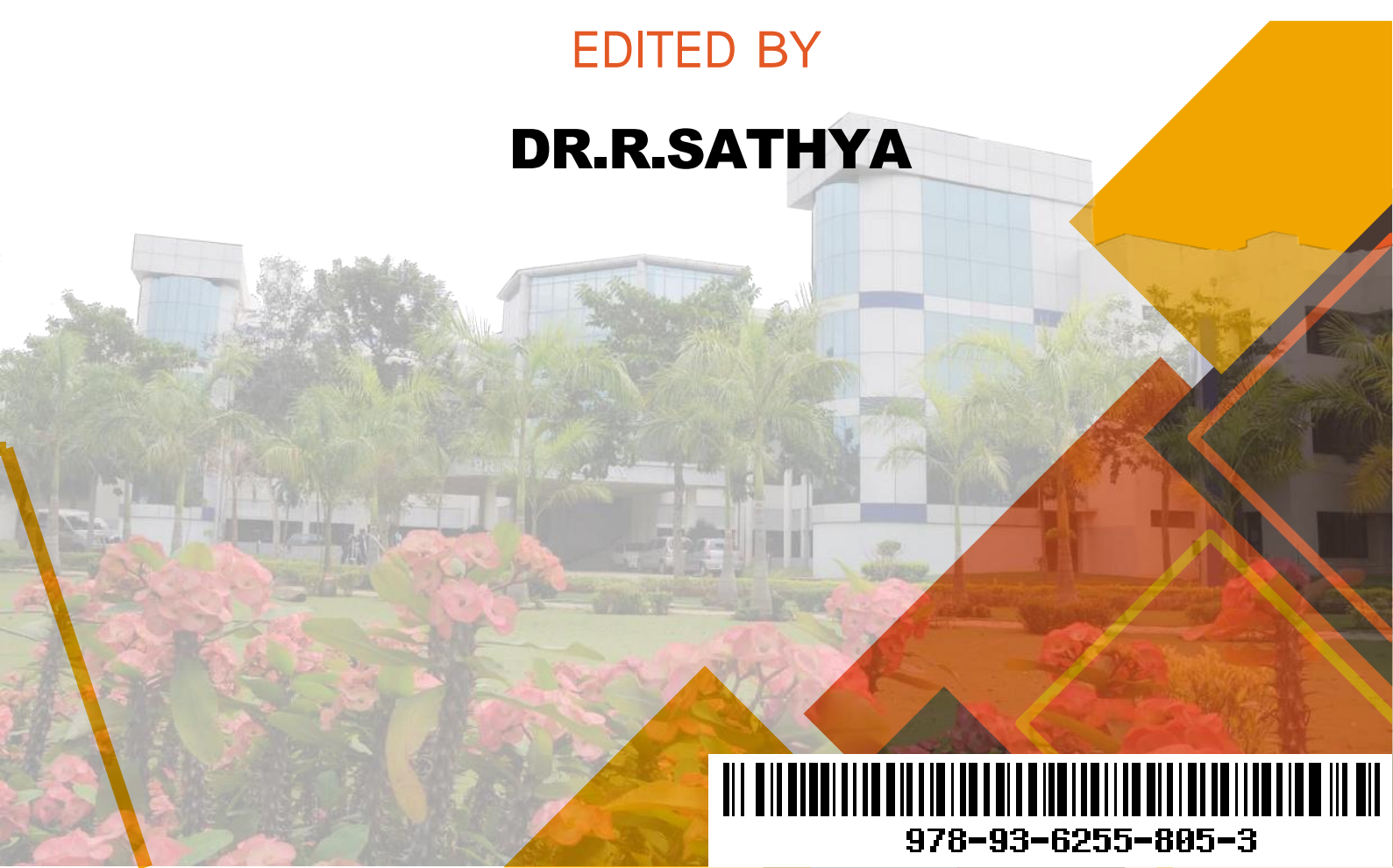

978-93-6255-805-3

Agricultural and Environmental Microbiology

Copyright©2023 by **Dr.N.MAHALAKSHIMI**

All rights reserved. No part of this book may be reproduced or transmitted in any form or by any means without written permission from the author.

ISBN: 978-93-6255-805-3

Publisher: Ponnaiyah Ramajayam Institute of Science and Technology (PRIST)

TABLE OF CONTENTS

| | |
|--|-----|
| Introduction | 8 |
| Chapter I :Introduction to Agricultural and Environmental Microbiology Dr. S. RAMESH | 20 |
| Chapter II : Soil Microbiology Dr.N.MAHALAKSHIMI | 26 |
| Chapter III: Plant-Microbe Interactions DR. K. SUNDAR | 34 |
| Chapter IV : Microbial Degradation of Organic Matter DR. T.USHADEVI | 46 |
| Chapter V: Microbes in Agrochemical Transformation DR.R.SATHYA | 53 |
| Chapter VI: Water Microbiology and Irrigation Systems DR.T.THIRUSELVI | 64 |
| Chapter VII: Microbial Biofertilizers DR.A.XAVIER FERNANDES | 77 |
| Chapter VIII : Waste Treatment and Bioremediation DR.G. CHANDIRASEGARAN | 99 |
| Chapter Ix : Environmental Microbiomes and Climate Change DR.K.P.KARUPPAIAN | 120 |
| Chapter X Advances in Agricultural Biotechnology DR.AMBIKA K | 132 |
| REFERENCES | 150 |

CHAPTER I

INTRODUCTION TO AGRICULTURAL AND ENVIRONMENTAL MICROBIOLOGY

Dr. S. RAMESH

Professor, Department of Microbiology, School of Arts and Science, Ponnaiyah Ramajeyam Institute of Science and technology, Tamilnadu, India

Agricultural and Environmental Microbiology is a specialized field that explores the roles of microorganisms in both agricultural ecosystems and the environment. These microorganisms, including bacteria, fungi, and viruses, are integral to processes such as nutrient cycling, soil health, and plant growth. By studying the interactions between microorganisms and their surroundings, this field helps in improving crop productivity, soil fertility, and sustainable agricultural practices.

One of the primary areas of focus is understanding the microbial communities in soil and their influence on plant health. Beneficial microbes promote plant growth through nitrogen fixation, phosphate solubilization, and the production of plant growth-promoting substances, while others help in decomposing organic matter, contributing to soil structure and nutrient availability. Moreover, microbial interventions are also applied to manage agricultural pests and diseases, offering eco-friendly alternatives to chemical pesticides.

In the environmental sector, microorganisms play a crucial role in bioremediation, waste management, and water purification. Microbial processes are harnessed to clean up pollutants, break down toxic substances, and manage waste in an environmentally sustainable manner.

Agricultural and Environmental Microbiology thus serves as a bridge between biological science and sustainable management practices, offering solutions to some of the most pressing global challenges in food security and environmental conservation.

CHAPTER II

SOIL MICROBIOLOGY

Dr.N.MAHALAKSHIMI

Assistant professor, Department of Microbiology, School of Arts and Science, Ponnaiyah Ramajeyam Institute of Science and technology, Tamilnadu, India

Soil microbiology is the study of microorganisms that live in the soil and play a crucial role in maintaining soil health and ecosystem functions. These microorganisms include bacteria, fungi, protozoa, and archaea, which are responsible for essential processes like nutrient cycling, organic matter decomposition, and nitrogen fixation. Their interactions with plants and other organisms also influence soil fertility and crop productivity, making them key players in sustainable agriculture.

Bacteria are the most abundant microorganisms in the soil, thriving in various environmental conditions and playing diverse roles. For instance, nitrifying bacteria convert ammonia into nitrate, making nitrogen available to plants, while decomposer bacteria break down organic matter into simpler compounds, enriching the soil. Fungi, on the other hand, form symbiotic relationships with plant roots (mycorrhizae), improving water and nutrient uptake, which is vital for plant health.

The health and diversity of soil microbial communities are influenced by factors such as soil type, pH, temperature, and human activities like farming and land use changes. Understanding and managing these microbial populations is essential for improving soil fertility, mitigating climate change through carbon sequestration, and promoting sustainable agricultural practices that reduce the need for chemical inputs.

CHAPTER III

PLANT-MICROBE INTERACTIONS

DR. K. SUNDAR

Assistant professor, Department of Microbiology, School of Arts and Science, Ponnaiyah Ramajeyam Institute of Science and technology, Tamilnadu, India

Plant-microbe interactions play a pivotal role in agricultural productivity and sustainability. These interactions encompass a diverse range of relationships, including mutualistic, commensal, and pathogenic associations. Beneficial microbes, such as mycorrhizal fungi and nitrogen-fixing bacteria, enhance plant nutrient uptake and promote growth, thereby contributing to healthier crops. In contrast, pathogenic microbes can cause significant yield losses by inducing diseases. Understanding these dynamics is essential for developing effective management strategies that harness beneficial interactions while mitigating the impacts of pathogens.

In the context of environmental microbiology, plant-microbe interactions also significantly influence soil health and ecosystem functioning. Microbial communities associated with plant roots help decompose organic matter, enhancing soil fertility and structure. Furthermore, these microbes play a crucial role in biogeochemical cycles, including carbon and nitrogen cycling, which are vital for maintaining ecosystem stability. By fostering healthy plant-microbe relationships, agricultural practices can improve soil health and resilience against environmental stresses, such as drought and soil erosion.

Advancements in molecular techniques and biotechnology are enabling researchers to unravel the complexities of plant-microbe interactions, paving the way for innovative solutions in agriculture. For instance, the application of beneficial microbes as biofertilizers and biocontrol agents is gaining traction as a sustainable alternative to chemical fertilizers and pesticides. Additionally, understanding the genetic and biochemical mechanisms underlying these interactions can lead to the development of crop varieties that are more resilient to stress and disease. Ultimately, integrating plant-microbe interactions into agricultural practices can enhance productivity while promoting environmental sustainability, making it a crucial area of study in both agriculture and environmental microbiology.

CHAPTER IV

MICROBIAL DEGRADATION OF ORGANIC MATTER

DR. T.USHADEVI

Associate professor, Department of Microbiology, School of Arts and Science, Ponnaiyah Ramajeyam Institute of Science and technology, Tamilnadu, India

Microbial degradation of organic matter plays a crucial role in both agriculture and environmental microbiology. This process involves the breakdown of complex organic compounds by microorganisms, such as bacteria and fungi, into simpler forms that can be assimilated by plants and other organisms. In agricultural systems, microbial activity enhances soil fertility by decomposing plant residues, animal manure, and other organic inputs, releasing essential nutrients like nitrogen, phosphorus, and potassium. This nutrient cycling is vital for sustainable agricultural practices, improving soil structure, water retention, and overall crop yield.

In the context of environmental microbiology, the degradation of organic matter is essential for waste management and pollution control. Microorganisms are employed in bioremediation processes to degrade contaminants in soil and water, transforming harmful organic pollutants into less toxic forms. This natural attenuation is vital in mitigating the effects of agricultural runoff, industrial discharges, and landfill leachates, thereby protecting ecosystems and human health. The ability of specific microbial communities to adapt to varying organic substrates further enhances their effectiveness in environmental restoration efforts.

Furthermore, understanding the mechanisms and factors influencing microbial degradation of organic matter is critical for optimizing these processes. Factors such as temperature, moisture, pH, and the availability of nutrients can significantly impact microbial activity and degradation rates. Advances in molecular techniques and bioinformatics are enabling researchers to explore the diversity and functionality of microbial communities involved in organic matter degradation, paving the way for innovative strategies to enhance soil health, improve crop productivity, and address environmental challenges. By leveraging the power of microbial degradation, we can work towards a more sustainable future in both agriculture and environmental management.

CHAPTER V

MICROBES IN AGROCHEMICAL TRANSFORMATION

DR.R.SATHYA

Assistant professor, Department of Microbiology, School of Arts and Science, Ponnaiyah Ramajeyam Institute of Science and technology, Tamilnadu, India

Microorganisms play a critical role in the transformation of agrochemicals, influencing both agricultural productivity and environmental health. In agricultural systems, these microbes facilitate the breakdown of fertilizers, pesticides, and herbicides, converting them into less toxic forms that can be readily utilized by plants. This biotransformation not only enhances nutrient availability but also minimizes the accumulation of harmful residues in the soil and water systems. By engaging in microbial degradation, we can foster more sustainable farming practices, leading to increased crop yields while reducing the reliance on chemical inputs.

In addition to promoting agricultural efficiency, the role of microbes in agrochemical transformation significantly impacts environmental microbiology. Soil-dwelling microbes, such as bacteria and fungi, contribute to the detoxification of contaminants found in agrochemicals, thus protecting soil and water quality. These microorganisms exhibit diverse metabolic pathways that enable them to degrade complex chemical structures, which can prevent the leaching of harmful substances into groundwater and reduce the risk of bioaccumulation in aquatic ecosystems. Furthermore, the understanding of these microbial processes can aid in the development of bioremediation strategies, harnessing natural microbial communities to restore polluted environments.

The integration of microbial processes into agrochemical management presents both challenges and opportunities for sustainable agriculture. Research into the diversity and functionality of microbial communities associated with agrochemicals is essential for optimizing their use and mitigating potential environmental impacts. Advances in biotechnology and genomics offer promising avenues for enhancing the efficacy of beneficial microbes, potentially leading to the development of bio-based agrochemical formulations that are safer for both ecosystems and human health. Overall, the strategic use of microbes in agrochemical transformation holds the key to achieving a balance between agricultural productivity and environmental sustainability.

CHAPTER VI

WATER MICROBIOLOGY AND IRRIGATION SYSTEMS

DR.T.THIRUSELVI

Assistant professor, Department of Microbiology, School of Arts and Science, Ponnaiyah Ramajeyam Institute of Science and technology, Tamilnadu, India

Water microbiology plays a critical role in understanding the dynamics of irrigation systems within agriculture and environmental microbiology. The quality of water used in irrigation directly influences crop health and productivity. Microbial communities in water sources can affect nutrient availability, pathogen prevalence, and the overall microbial ecology of the soil. By studying these microorganisms, researchers can identify potential risks, such as the presence of harmful pathogens or toxins, and develop strategies to mitigate their impact on agricultural output and food safety.

Moreover, the interaction between water and soil microbiomes is essential for sustainable agricultural practices. Microbial populations in irrigation water can contribute to soil health by enhancing nutrient cycling and organic matter decomposition. For instance, beneficial microbes can improve soil structure, promote root growth, and enhance the bioavailability of essential nutrients, ultimately leading to improved crop yields. Understanding these interactions is crucial for designing irrigation systems that not only support agricultural productivity but also protect environmental quality.

Finally, effective management of water resources in agriculture requires a comprehensive understanding of the microbiological aspects of irrigation systems. Monitoring water quality and microbial content can provide valuable insights for farmers and policymakers to ensure the sustainability of agricultural practices. By integrating water microbiology into the management of irrigation systems, we can enhance agricultural resilience against climate change and safeguard ecosystem health, thereby promoting a balance between agricultural productivity and environmental stewardship.

CHAPTER VII

MICROBIAL BIOFERTILIZERS

DR.A.XAVIER FERNANDES

Assistant professor, Department of Microbiology, School of Arts and Science, Ponnaiyah Ramajeyam Institute of Science and technology, Tamilnadu, India

Microbial biofertilizers represent a promising solution to enhance agricultural productivity while promoting sustainable farming practices. These formulations contain live microorganisms that, when applied to seeds or soil, stimulate plant growth by improving nutrient availability, promoting root development, and enhancing soil health. For instance, beneficial bacteria such as *Rhizobium*, *Azotobacter*, and *Pseudomonas* can fix atmospheric nitrogen or solubilize phosphorus, making these essential nutrients more accessible to plants. As a result, the use of microbial biofertilizers can lead to reduced dependence on chemical fertilizers, contributing to more environmentally friendly agricultural practices.

In the context of environmental microbiology, microbial biofertilizers play a crucial role in soil bioremediation and ecosystem health. By introducing specific strains of microorganisms into degraded or contaminated soils, these biofertilizers can enhance the degradation of pollutants, restore soil fertility, and support microbial diversity. This ecological approach not only aids in reclaiming land affected by pollution but also fosters the development of resilient agricultural systems that can better withstand environmental stressors, such as drought or soil erosion.

Furthermore, the integration of microbial biofertilizers into agricultural practices aligns with the principles of sustainable development by promoting the efficient use of natural resources. Their application can lead to improved crop yields, reduced chemical inputs, and enhanced biodiversity. As research continues to uncover the diverse functions and benefits of microbial communities in agriculture, the potential for biofertilizers to support sustainable farming systems and contribute to environmental conservation becomes increasingly clear, making them an essential component of future agricultural strategies.

CHAPTER VIII

WASTE TREATMENT AND BIOREMEDIATION

DR.G. CHANDIRASEGARAN

Assistant professor, Department of Microbiology, School of Arts and Science, Ponnaiyah Ramajeyam Institute of Science and technology, Tamilnadu, India

Waste treatment and bioremediation are critical components in agriculture and environmental microbiology, aimed at addressing the challenges posed by organic waste and environmental contaminants. Agricultural practices often generate substantial organic waste, which, if not managed properly, can lead to soil and water pollution. Effective waste treatment methods, such as composting and anaerobic digestion, not only help in reducing the volume of waste but also enhance soil fertility by returning valuable nutrients to the soil. These processes leverage microbial activity to decompose organic matter, transforming waste into useful products like compost or biogas, thus promoting sustainable agricultural practices.

Bioremediation utilizes microorganisms to detoxify and restore polluted environments, making it a powerful tool in environmental microbiology. Various bioremediation strategies, including phytoremediation, bioaugmentation, and biostimulation, employ natural or engineered microbial populations to break down harmful substances such as pesticides, heavy metals, and petroleum hydrocarbons. These microorganisms can metabolize contaminants, converting them into less harmful compounds, thereby improving soil and water quality. The selection of appropriate microbial strains is crucial for the efficiency of bioremediation processes, highlighting the need for ongoing research in microbial ecology and biotechnology.

The integration of waste treatment and bioremediation strategies can lead to more sustainable agricultural systems and healthier ecosystems. By effectively managing agricultural waste and employing bioremediation techniques, we can mitigate environmental pollution and promote the recovery of degraded lands. This holistic approach not only enhances crop production and soil health but also fosters resilience against environmental challenges, making it essential for achieving sustainable development goals in agriculture and environmental conservation.

CHAPTER IX

ENVIRONMENTAL MICROBIOMES AND CLIMATE CHANGE

DR.K.P.KARUPPAIAN

Assistant professor, Department of Microbiology, School of Arts and Science, Ponnaiyah Ramajeyam Institute of Science and technology, Tamilnadu, India

Environmental microbiomes play a pivotal role in agriculture, influencing soil health, plant growth, and crop yields. Microbial communities in the soil are crucial for nutrient cycling, decomposition, and the suppression of plant diseases. As climate change alters temperature and precipitation patterns, these microbiomes may shift in composition and function, impacting their ability to support sustainable agricultural practices. For instance, changes in microbial diversity can affect soil fertility, water retention, and the availability of essential nutrients, ultimately threatening food security.

The interplay between climate change and environmental microbiomes can also lead to feedback loops that exacerbate global warming. Certain microbial processes, such as denitrification and methane production, can release greenhouse gases into the atmosphere. Additionally, the altered microbial activity under changing climatic conditions may influence the soil's carbon storage capacity. Therefore, understanding the dynamics of these microbial communities is vital for predicting how agricultural systems might respond to climate change and for developing strategies to mitigate its impacts.

To enhance resilience in agricultural systems, integrating microbiome management practices is essential. Approaches such as the application of beneficial microbes, conservation tillage, and crop rotation can help promote healthy microbiomes, improving soil structure and function. Moreover, leveraging advances in environmental microbiology, such as metagenomics and bioinformatics, can provide insights into microbial diversity and functionality, enabling tailored interventions that bolster ecosystem services. By focusing on the symbiotic relationship between microbiomes and climate resilience, we can foster sustainable agricultural practices that adapt to the challenges posed by a changing climate.

CHAPTER X

ADVANCES IN AGRICULTURAL BIOTECHNOLOGY

DR.AMBIKA K

Assistant professor, Department of Microbiology, School of Arts and Science, Ponnaiyah Ramajeyam Institute of Science and technology, Tamilnadu, India

Agricultural biotechnology has revolutionized the way we approach food production, environmental sustainability, and pest management. Through genetic engineering, scientists can enhance crop resistance to pests, diseases, and abiotic stresses, resulting in higher yields and reduced dependency on chemical inputs. Innovations such as CRISPR-Cas9 have enabled precise modifications at the genomic level, allowing for the development of crops with improved nutritional profiles, longer shelf lives, and better adaptability to changing climatic conditions. These advancements not only boost agricultural productivity but also contribute to food security in a world facing an ever-growing population.

In the realm of environmental microbiology, the integration of biotechnology has led to significant breakthroughs in soil health and nutrient management. The use of biofertilizers and biopesticides derived from beneficial microorganisms has emerged as a sustainable alternative to conventional fertilizers and pesticides. These biological agents enhance soil fertility, promote plant growth, and suppress plant pathogens, thereby minimizing environmental impacts and fostering a more balanced ecosystem. Additionally, the application of microbial biotechnology in bioremediation offers promising solutions for contaminated soils and water, utilizing microorganisms to degrade pollutants and restore environmental health.

As we move forward, the synergy between agricultural biotechnology and environmental microbiology is expected to play a crucial role in addressing the challenges of climate change and resource scarcity. Continued research and innovation in this field will facilitate the development of sustainable agricultural practices that align with environmental conservation goals. By harnessing the power of biotechnology, we can create resilient agricultural systems that not only meet the demands of modern society but also protect and restore our natural ecosystems for future generations.

MUTATION

EDITED BY

DR. A. XAVIER FERNANDES



978-93-6255-018-7

Mutation

Copyright©2023 by **DR. A. XAVIER FERNANDES**

All rights reserved. No part of this book may be reproduced or transmitted in any form or by any means without written permission from the author.

ISBN: 978-93-6255-018-7

Publisher: Ponnaiyah Ramajayam Institute of Science and Technology (PRIST)

TABLE OF CONTENTS

| | |
|---|-----|
| Introduction | 8 |
| Chapter I :Introduction to Mutations Dr. S. RAMESH | 20 |
| Chapter II :Molecular Basis of Mutations Dr.S.MOHANRAJ | 26 |
| Chapter III: Environmental Factors and Mutagenesis DR. K. SUNDAR | 34 |
| Chapter IV : Mutation and DNA Repair Mechanisms DR. T.USHADEVI | 46 |
| Chapter V: Mutations in Evolution DR.R.SATHYA | 53 |
| Chapter VI: Mutations in Human Disease DR.T.THIRUSELVI | 64 |
| Chapter VII: Viral Mutations DR.A.XAVIER FERNANDES | 77 |
| Chapter VIII : Mutation Detection and Genomic Analysis DR.G. CHANDIRASEGARAN | 99 |
| Chapter Ix : Artificial Mutagenesis in Research and Biotechnology DR.K.P.KARUPPAIAN | 120 |
| Chapter X Ethical and Social Implications of Mutations DR.AMBIKA K | 132 |
| REFERENCES | 150 |

CHAPTER I

INTRODUCTION TO MUTATIONS

Dr. S. RAMESH

Professor, Department of Microbiology, School of Arts and Science, Ponnaiyah Ramajeyam Institute of Science and technology, Tamilnadu, India

Mutations are fundamental changes in the DNA sequence that can occur naturally or as a result of environmental factors. These alterations can range from a single nucleotide change to large-scale chromosomal rearrangements. Mutations play a critical role in the process of evolution, as they introduce genetic variability within populations. This variability is essential for natural selection, enabling species to adapt to changing environments. However, not all mutations are beneficial; many can be deleterious, leading to diseases and other health issues in organisms.

There are several types of mutations, including point mutations, insertions, deletions, and duplications. Point mutations involve the substitution of one nucleotide for another, which can lead to silent, missense, or nonsense mutations, depending on the effect on the resulting protein. Insertions and deletions can disrupt the reading frame of a gene, potentially altering the entire amino acid sequence downstream. Duplications can increase the amount of genetic material, which may lead to gene overexpression or other functional changes. Understanding these various mutations is crucial for fields such as genetics, medicine, and evolutionary biology.

The study of mutations has significant implications for human health and disease. Many genetic disorders, such as cystic fibrosis and sickle cell anemia, are caused by specific mutations in critical genes. Moreover, mutations play a role in the development of cancer, as accumulated genetic changes can lead to uncontrolled cell growth. Advances in genetic research and technologies, such as CRISPR and next-generation sequencing, have enhanced our ability to detect and study mutations. This knowledge not only aids in diagnosing and treating genetic diseases but also in understanding the underlying mechanisms of evolution and species adaptation.

CHAPTER II

Molecular Basis of Mutations

Dr.S.MOHANRAJ

Associate professor, Department of Microbiology, School of Arts and Science, Ponnaiyah Ramajeyam Institute of Science and technology, Tamilnadu, India

Mutations are alterations in the DNA sequence that can occur at various levels, from single nucleotide changes to large chromosomal rearrangements. The molecular basis of mutations primarily involves errors in DNA replication, exposure to environmental factors, or spontaneous chemical changes in the DNA molecule. During DNA replication, if the DNA polymerase enzyme incorporates the wrong nucleotide, it can lead to a point mutation. Additionally, external factors such as ultraviolet light, ionizing radiation, and certain chemicals can cause DNA damage, leading to mutations. These environmental agents can induce various types of damage, such as base pair substitutions, deletions, or insertions.

Another important aspect of the molecular basis of mutations is the role of repair mechanisms. Cells possess several DNA repair pathways, including nucleotide excision repair, base excision repair, and mismatch repair, which help to correct errors that occur during DNA replication or due to environmental damage. When these repair mechanisms fail or are overwhelmed, the mutations can become permanent and may contribute to the evolution of organisms. However, the effectiveness of these repair systems can vary, leading to differences in mutation rates among organisms and even among different tissues within the same organism.

Mutations can have diverse consequences, ranging from benign variations to deleterious effects, depending on their nature and location within the genome. For instance, a mutation in a coding region of a gene can lead to an altered protein product, potentially disrupting normal cellular functions. Conversely, mutations occurring in non-coding regions may not have any immediate effects. In some cases, certain mutations can confer advantages, such as increased resistance to diseases, driving evolutionary change. Thus, understanding the molecular basis of mutations is crucial for fields such as genetics, evolutionary biology, and medicine, as it informs us about genetic diversity, disease mechanisms, and the potential for targeted therapies.

CHAPTER III

ENVIRONMENTAL FACTORS AND MUTAGENESIS

DR. K. SUNDAR

Associate professor, Department of Microbiology, School of Arts and Science, Ponnaiyah Ramajeyam Institute of Science and technology, Tamilnadu, India

Environmental factors play a crucial role in the process of mutagenesis, which is the initiation of mutations in the genetic material of organisms. These factors can be broadly categorized into physical, chemical, and biological agents. Physical agents, such as ultraviolet (UV) radiation and ionizing radiation, can cause direct damage to DNA, leading to alterations in nucleotide sequences. Chemical agents, including certain pesticides, heavy metals, and industrial pollutants, can also interact with DNA and result in various types of mutations, such as base substitutions or frameshift mutations. Understanding how these environmental factors induce mutations is vital for assessing their potential impacts on health and biodiversity.

The mechanisms through which environmental factors induce mutations are diverse and complex. For instance, UV radiation can cause the formation of pyrimidine dimers, which disrupt normal base pairing during DNA replication. Similarly, chemical mutagens may modify bases or interfere with DNA repair mechanisms, resulting in permanent changes in the genetic code. These mutations can either be beneficial, harmful, or neutral to the organism, depending on their nature and the environmental context in which they occur. The study of mutagenesis is essential for comprehending how organisms adapt to changing environments and how certain mutations may lead to diseases, including cancer.

Moreover, the interplay between environmental factors and mutagenesis raises significant concerns for public health and environmental policy. The increasing exposure to various mutagens in our surroundings necessitates ongoing research to identify and mitigate risks associated with these agents. For instance, regulatory measures to limit exposure to known chemical mutagens can significantly reduce mutation rates and, consequently, the incidence of mutation-related diseases. Ultimately, a comprehensive understanding of the relationship between environmental factors and mutagenesis will aid in developing effective strategies for disease prevention and promoting sustainable environmental practices.

CHAPTER IV

MUTATION AND DNA REPAIR MECHANISMS

DR. T.USHADEVI

Assistant professor, Department of Microbiology, School of Arts and Science, Ponnaiyah Ramajeyam Institute of Science and technology, Tamilnadu, India

Mutations are permanent alterations in the nucleotide sequence of DNA that can have significant effects on an organism's phenotype and overall fitness. These changes can arise from various sources, including environmental factors such as radiation and chemicals, as well as internal processes like errors during DNA replication. Mutations can be classified into several types, including point mutations, insertions, deletions, and chromosomal mutations. The consequences of mutations can range from benign to detrimental, affecting gene function and potentially leading to diseases, including cancer.

The cellular machinery is equipped with multiple DNA repair mechanisms to counteract the detrimental effects of mutations. One of the primary repair systems is the mismatch repair pathway, which corrects errors that occur during DNA replication. This mechanism recognizes and excises mismatched bases, replacing them with the correct nucleotides. Another crucial repair process is base excision repair, which addresses small, non-helix-distorting base lesions caused by oxidative stress or alkylation. Additionally, nucleotide excision repair is essential for removing bulky DNA adducts, such as those formed from UV light exposure, thus preserving genomic integrity.

Despite these sophisticated repair systems, not all mutations are rectified, and some can persist and accumulate over time. The balance between mutation and repair is vital for evolution, as it drives genetic diversity, which is essential for adaptation. However, excessive mutations, especially in critical genes involved in cell cycle regulation or DNA repair, can lead to tumorigenesis and other genetic disorders. Understanding the interplay between mutations and DNA repair mechanisms is fundamental for developing therapeutic strategies aimed at mitigating the effects of harmful mutations and enhancing cellular resilience.

CHAPTER V

MUTATIONS IN EVOLUTION

DR.R.SATHYA

Assistant professor, Department of Microbiology, School of Arts and Science, Ponnaiyah Ramajeyam Institute of Science and technology, Tamilnadu, India

Mutations are fundamental changes in the genetic sequence of an organism, and they serve as the raw material for evolutionary processes. These alterations can occur naturally during DNA replication or be induced by environmental factors such as radiation or chemicals. While many mutations are neutral or even harmful, some confer advantageous traits that enhance an organism's ability to survive and reproduce in its environment. This variability is crucial for the process of natural selection, as it allows populations to adapt over generations to changing conditions.

The role of mutations in evolution is particularly evident in the context of genetic diversity. Populations with a higher mutation rate can adapt more quickly to environmental shifts, making them more resilient to challenges such as climate change, diseases, or habitat destruction. For example, mutations that provide resistance to a specific pathogen can lead to a significant survival advantage, ensuring that those organisms pass their beneficial traits to future generations. Over time, these mutations can accumulate, leading to the emergence of new species or significant changes within existing ones.

Furthermore, mutations can also drive the process of speciation. As mutations accumulate in isolated populations, they can lead to the development of distinct characteristics that differentiate these groups from their ancestral forms. This divergence is often accelerated by selective pressures in different environments, which can favor different traits in separate populations. Ultimately, the interplay of mutations, natural selection, and environmental factors shapes the complexity of life on Earth, highlighting the critical role that genetic change plays in the ongoing process of evolution.

CHAPTER VI

MUTATIONS IN HUMAN DISEASE

DR.T.THIRUSELVI

Assistant professor, Department of Microbiology, School of Arts and Science, Ponnaiyah Ramajeyam Institute of Science and technology, Tamilnadu, India

Mutations, defined as permanent alterations in the DNA sequence, play a critical role in the development and progression of various human diseases. They can arise from environmental factors, such as radiation and chemicals, or occur spontaneously during DNA replication. These genetic changes can lead to a range of effects on gene function, potentially disrupting normal cellular processes. For example, a mutation in a single gene can lead to hereditary conditions like cystic fibrosis or sickle cell anemia, demonstrating how specific alterations in the genetic code can have profound implications for human health.

The consequences of mutations can be classified into several categories: benign, pathogenic, or likely pathogenic. Benign mutations do not significantly affect the organism's health, while pathogenic mutations are directly linked to disease. In some cases, mutations may confer a selective advantage; for instance, individuals with a specific mutation in the hemoglobin gene are resistant to malaria. However, such beneficial mutations are often the exception rather than the rule. Most mutations contribute to disease through mechanisms like loss of function, where the normal protein product is reduced or absent, or gain of function, where the protein becomes overly active or acquires a new activity.

Understanding the role of mutations in disease has significant implications for diagnosis, treatment, and prevention. Advances in genomic technologies, such as next-generation sequencing, allow for the identification of mutations associated with various diseases, paving the way for personalized medicine. By tailoring treatment strategies based on an individual's unique genetic makeup, healthcare providers can improve outcomes and reduce the incidence of adverse effects. Furthermore, ongoing research into the mechanisms by which mutations contribute to disease continues to enhance our understanding of human biology and may lead to the development of novel therapeutic approaches.

CHAPTER VII

VIRAL MUTATIONS

DR.A.XAVIER FERNANDES

Assistant professor, Department of Microbiology, School of Arts and Science, Ponnaiyah Ramajeyam Institute of Science and technology, Tamilnadu, India

Viral mutations are changes that occur in the genetic material of a virus. These mutations can arise during replication when the virus reproduces itself within a host cell. Unlike human DNA, viral genomes—whether RNA or DNA—often lack the sophisticated error-checking mechanisms that help prevent mutations. As a result, mutations can accumulate quickly, leading to genetic diversity among viral populations. This rapid evolution is particularly evident in RNA viruses, such as influenza and coronaviruses, which can exhibit high mutation rates.

The implications of viral mutations are significant for public health and disease management. Some mutations can enhance a virus's ability to infect hosts, evade the immune response, or develop resistance to antiviral drugs. For example, mutations in the spike protein of the SARS-CoV-2 virus have been linked to increased transmissibility and changes in vaccine effectiveness. These mutations can lead to the emergence of new variants, which may necessitate updates to vaccines or treatments and pose challenges for controlling outbreaks.

Understanding viral mutations is critical for developing effective strategies to combat viral infections. Scientists use genomic surveillance to monitor the spread of mutations and their potential impacts on transmissibility and virulence. By identifying significant mutations, researchers can inform public health responses, vaccine development, and therapeutic interventions. Continuous monitoring and research into viral mutations will be essential to stay ahead of evolving viruses and mitigate their impact on global health.

CHAPTER VIII

MUTATION DETECTION AND GENOMIC ANALYSIS

DR.G. CHANDIRASEGARAN

Assistant professor, Department of Microbiology, School of Arts and Science, Ponnaiyah Ramajeyam Institute of Science and technology, Tamilnadu, India

Mutations are alterations in the DNA sequence that can lead to significant biological consequences, ranging from benign variations to severe diseases. Detecting these mutations is crucial for understanding genetic diseases, evolutionary biology, and cancer research. Various methods are employed to identify mutations, including sequencing techniques such as Sanger sequencing and next-generation sequencing (NGS). These methods allow for comprehensive analysis of genomes, enabling researchers to detect single nucleotide polymorphisms (SNPs), insertions, deletions, and larger structural variants. The accuracy and throughput of NGS have revolutionized mutation detection, facilitating large-scale studies and personalized medicine approaches.

Once mutations are detected, genomic analysis becomes essential for interpreting their effects on phenotype and disease susceptibility. Bioinformatics tools play a vital role in this analysis by processing and analyzing the vast amounts of data generated by sequencing technologies. These tools can predict the functional impact of mutations, categorize them based on their potential pathogenicity, and associate them with clinical outcomes. Furthermore, comparative genomics can provide insights into the evolutionary significance of mutations, helping researchers understand how specific genetic changes contribute to phenotypic diversity and adaptation in populations.

The integration of mutation detection and genomic analysis holds great promise for advancing precision medicine. By identifying mutations associated with specific diseases, clinicians can tailor treatments to individual patients, enhancing therapeutic efficacy and minimizing adverse effects. Moreover, ongoing research in mutation detection technologies and genomic analysis is expected to yield new biomarkers for disease diagnosis and prognosis, ultimately improving patient outcomes. As our understanding of the genetic basis of diseases deepens, the importance of effective mutation detection and comprehensive genomic analysis will continue to grow in both clinical and research settings.

CHAPTER IX

ARTIFICIAL MUTAGENESIS IN RESEARCH AND BIOTECHNOLOGY

DR.K.P.KARUPPAIAN

Assistant professor, Department of Microbiology, School of Arts and Science, Ponnaiyah Ramajeyam Institute of Science and technology, Tamilnadu, India

Artificial mutagenesis is a powerful technique employed in research and biotechnology to induce mutations in organisms systematically. This process involves the application of various physical, chemical, or biological agents to modify the genetic material, resulting in changes to an organism's phenotype. By creating specific mutations, researchers can study gene function, elucidate metabolic pathways, and develop organisms with desirable traits, such as increased yield in crops or enhanced resistance to diseases. This targeted approach allows for a deeper understanding of genetic mechanisms and provides a platform for innovative biotechnological applications.

In the realm of molecular biology, artificial mutagenesis is often utilized to generate mutant strains that can be studied for their functional characteristics. Techniques such as site-directed mutagenesis, where specific nucleotide sequences are altered, enable researchers to pinpoint the roles of particular genes. This method is invaluable for unraveling complex biological processes, including protein interactions and enzyme activities. Furthermore, the ability to introduce precise mutations opens avenues for genetic engineering, leading to the development of novel bioproducts, therapeutic proteins, and genetically modified organisms (GMOs).

The implications of artificial mutagenesis extend beyond basic research; they have profound applications in agriculture, medicine, and environmental sciences. In agriculture, for instance, mutagenesis can create crop varieties with improved traits, such as drought tolerance or enhanced nutritional profiles. In medicine, mutated microorganisms can be engineered to produce pharmaceuticals or degrade environmental pollutants. Overall, artificial mutagenesis serves as a crucial tool in advancing our understanding of genetics and enhancing biotechnological innovations, thereby contributing to sustainable development and improved quality of life.

CHAPTER X

ETHICAL AND SOCIAL IMPLICATIONS OF MUTATIONS

DR.AMBIKA K

Assistant professor, Department of Microbiology, School of Arts and Science, Ponnaiyah Ramajeyam Institute of Science and technology, Tamilnadu, India

Mutations, defined as changes in the DNA sequence, can have profound ethical and social implications that permeate various aspects of society. One significant concern revolves around genetic discrimination. As advancements in genomic technologies facilitate the identification of mutations linked to specific diseases, there is a risk that individuals may face discrimination in areas such as employment and insurance based on their genetic information. This possibility raises ethical questions regarding privacy and the right to access one's genetic data, necessitating a reevaluation of existing policies and regulations to protect individuals from potential exploitation and bias.

Another critical issue is the application of gene editing technologies, such as CRISPR, which enable precise modifications to an organism's genetic makeup. While these technologies hold the potential to eradicate genetic disorders and enhance human health, they also pose ethical dilemmas regarding "designer babies" and the social consequences of creating genetically modified organisms. The prospect of choosing desirable traits could exacerbate existing social inequalities, leading to a society where genetic enhancements are only accessible to the affluent. This scenario raises moral questions about the naturalness of human evolution and the extent to which humans should intervene in their genetic heritage.

Furthermore, mutations can have significant implications for biodiversity and ecosystem health. Genetic mutations in wild populations can influence adaptability and resilience to environmental changes. The introduction of genetically modified organisms into ecosystems may disrupt existing ecological balances, leading to unforeseen consequences. The ethical responsibility to safeguard biodiversity and ensure the health of ecosystems calls for careful consideration of the long-term effects of both natural and induced mutations. As our understanding of genetics deepens, the intersection of science, ethics, and society must be navigated thoughtfully to promote equitable and sustainable advancements.



NANO SCIENCE AND TECHNOLOGY

EDITED BY



DR. C. THENMOZHI



978-93-6255-758-2

Nano Science and Technology
Copyright © 2023 by *Dr. C. Thenmozhi*

All rights reserved. No part of this book may be reproduced or transmitted in any form or by any means without written permission from the author.

ISBN: 978-93-6255-758-2

Publisher: Ponnaiyah Ramajayam Institute of Science and Technology (PRIST)

TABLE OF CONTENTS

| | |
|--|-----|
| Introduction..... | 20 |
| CHAPTER 1 Overview of Nanoscience..... | 21 |
| <i>Dr. C. Thenmozhi</i> | |
| CHAPTER 2 Different Classes of Nanomaterials | 32 |
| <i>Dr. Sutapa Ghosh</i> | |
| CHAPTER 3 Synthesis of Nanomaterials | 40 |
| <i>Dr. L. Chinnappa</i> | |
| CHAPTER 4 Characterization of Nanomaterials | 52 |
| <i>Dr. S. Subashchandrabose</i> | |
| CHAPTER 5 Nanophotonics | 70 |
| <i>Dr. M. Sivanantham</i> | |
| CHAPTER 6 Nanoelectronics | 89 |
| <i>Dr. K. Thirunavukarasu and Dr. R. Muraleedharan</i> | |
| CHAPTER 7 Applications of Nanomaterials..... | 107 |
| <i>Dr. M. Sivanantham and Dr. M. Silambarasan</i> | |
| REFERENCES..... | 126 |

CHAPTER 1

Overview of Nanoscience

Dr. C. Thenmozhi

*Department of Physics, PRIST Deemed to be University,
Thanjavur-613403, Tamilnadu, India*

Introduction

Nanoscience is the study of matter at the nanoscale, where dimensions range from approximately 1 to 100 nanometers (nm). At this scale, materials exhibit unique physical, chemical, and biological properties that differ significantly from their bulk counterparts. These novel characteristics arise due to the increased surface area, quantum effects, and the dominance of surface and interface phenomena. Nanoscience encompasses the exploration, understanding, and manipulation of these properties, providing a foundation for the rapidly growing field of nanotechnology.

Nanoscience offers a transformative approach to understanding and manipulating the fundamental building blocks of matter. By exploring the unique properties of materials at the nanoscale, researchers are developing innovative solutions to some of the most pressing challenges in technology, health, and the environment. As the field continues to evolve, nanoscience holds the promise of unlocking unprecedented capabilities and ushering in a new era of scientific and technological advancements.

The Nanoscale and Its Importance

The nanoscale is incredibly small—one nanometer is one billionth of a meter, or about 80,000 times smaller than the diameter of a human hair. At this scale, the behavior of materials is governed by the laws of quantum mechanics rather than classical physics. This can result in dramatic changes in properties such as electrical conductivity, optical behavior, strength, and reactivity.

For instance, gold nanoparticles can appear red or purple depending on their size, and carbon, when structured as graphene, exhibits exceptional electrical conductivity and

CHAPTER 2

Different Classes of Nanomaterials

Dr. Sutapa Ghosh

*Department of Physics, PRIST Deemed to be University,
Thanjavur-613403, Tamilnadu, India*

Introduction

Nanomaterials are materials with at least one dimension in the nanometer range (1-100 nm), exhibiting unique properties due to their small size and large surface area. They are categorized into different classes based on their dimensions, composition, shape, and structure. These classes include zero-dimensional (0D), one-dimensional (1D), two-dimensional (2D), and three-dimensional (3D) nanomaterials, each with distinct characteristics and applications. Nanomaterials are a diverse group of materials with a wide range of structures and properties, classified into 0D, 1D, 2D, and 3D categories based on their dimensions. Understanding these different classes is essential for exploring their potential in fields such as electronics, medicine, energy, and environmental science. Each class of nanomaterials offers unique properties that enable a variety of applications across multiple fields, including electronics, medicine, energy, and environmental science. As research and technology continue to advance, the development of new nanomaterials and their innovative applications will play a critical role in addressing global challenges and improving human life.

Zero-Dimensional (0D) Nanomaterials

Zero-dimensional nanomaterials have all three dimensions confined within the nanoscale. They are typically nanoparticles, nanodots, or quantum dots, which are often spherical or nearly spherical in shape.

Examples: Quantum dots, metallic nanoparticles (e.g., gold, silver), and semiconductor nanodots.

Properties: These materials exhibit quantum confinement effects, where the electronic properties are highly dependent on their size. Quantum dots, for example, display size-dependent

CHAPTER 3

Synthesis of Nanomaterials

Dr. L. Chinnappa

*Department of Physics, PRIST Deemed to be University,
Thanjavur-613403, Tamilnadu, India*

Introduction

The synthesis of nanomaterials is a fundamental aspect of nanoscience and nanotechnology, involving the creation of materials with at least one dimension in the nanoscale range (1-100 nm). These materials exhibit unique physical, chemical, and biological properties due to their small size and large surface area. The synthesis process determines the size, shape, composition, and structure of the nanomaterials, which in turn dictate their properties and applications. There are two main approaches to synthesizing nanomaterials: top-down and bottom-up methods, each with its own advantages, challenges, and techniques.

The synthesis of nanomaterials is a crucial area of research in nanoscience, offering methods to create materials with tailored properties for specific applications. By mastering top-down and bottom-up techniques, scientists can manipulate materials at the atomic and molecular levels, unlocking new possibilities in technology, medicine, and environmental sustainability. As the field continues to advance, innovative synthesis methods will play a pivotal role in the development of next-generation nanomaterials with enhanced performance and functionality.

Top-Down Synthesis Methods

Top-down approaches involve breaking down bulk materials into nanoscale structures using physical or chemical processes. These methods are typically used to create well-defined nanostructures and are particularly useful for materials like nanowires and thin films.

Mechanical Milling:

This technique involves grinding bulk materials into fine powders using high-energy ball mills. It is suitable for

CHAPTER 4

Characterization of Nanomaterials

Dr. S. Subashchandrabose

*Department of Physics, PRIST Deemed to be University,
Thanjavur-613403, Tamilnadu, India*

Introduction

Characterization of nanomaterials is a critical aspect of nanoscience, involving the detailed analysis and measurement of their physical, chemical, and structural properties. Due to their unique characteristics at the nanoscale, including increased surface area and quantum effects, understanding these materials is essential for optimizing their applications in various fields such as electronics, medicine, energy, and environmental science. Accurate characterization methods enable researchers to establish relationships between a nanomaterial's structure and its properties, facilitating the development of tailored materials for specific applications.

The characterization of nanomaterials is a vital component of nanoscience, enabling researchers to uncover the unique properties that distinguish these materials from their bulk counterparts. Through a combination of microscopy, spectroscopy, thermal analysis, and other techniques, scientists can gain a comprehensive understanding of nanomaterials' structure and behavior. As the field continues to evolve, advances in characterization methods will be essential for optimizing the design and application of nanomaterials across diverse industries, ultimately driving innovation and technological progress.

Importance of Characterization

Nanomaterials often exhibit distinct behaviors compared to their bulk counterparts, making characterization essential for ensuring their functionality, safety, and effectiveness. Characterization helps in:

Determining Size and Shape: The dimensions and morphology of nanomaterials influence their properties and performance.

CHAPTER 5
Nanophotonics
Dr. M. Sivanantham

*Department of Physics, PRIST Deemed to be University,
Thanjavur-613403, Tamilnadu, India*

Introduction

Nanophotonics is a multidisciplinary field that investigates the interactions between light (photons) and nanostructured materials. This area of study emerges from the convergence of nanotechnology and photonics, focusing on manipulating light at the nanoscale—typically within dimensions of 1 to 100 nanometers. As materials approach this scale, their optical properties can change dramatically, leading to new phenomena such as plasmonic resonances, enhanced light-matter interactions, and unique emission properties. These characteristics make nanophotonics a pivotal area of research with broad applications across various domains, including telecommunications, medicine, energy, and sensing technologies.

Nanophotonics stands at the forefront of technological innovation, offering new possibilities for manipulating light at the nanoscale. By leveraging the unique optical properties of nanostructured materials, this field has the potential to revolutionize various industries, including telecommunications, medicine, and renewable energy. As research advances and new techniques are developed, nanophotonics will continue to unlock groundbreaking applications, driving progress in science and technology.

Key Concepts in Nanophotonics

Light-Matter Interaction:

At the nanoscale, the interaction between light and materials is governed by quantum mechanics. Nanophotonic materials can exhibit behaviors such as increased absorption, scattering, and emission, which are significantly different from their bulk counterparts.

Surface Plasmon Resonance (SPR):

CHAPTER 6

Nanoelectronics

Dr. K. Thirunavukarasu and Dr. R. Muraleedharan

*Department of Physics, PRIST Deemed to be University,
Thanjavur-613403, Tamilnadu, India*

Introduction

Nanoelectronics is an innovative field that focuses on the integration of nanoscale materials and devices into electronic systems. By manipulating matter at the atomic and molecular levels, nanoelectronics aims to enhance the performance, efficiency, and functionality of electronic components far beyond the capabilities of traditional microelectronics. As technology trends towards miniaturization and increased computational power, nanoelectronics has emerged as a pivotal area of research, with significant implications for computing, telecommunications, and various other applications.

Nanoelectronics represents a transformative shift in the field of electronics, offering the potential for enhanced performance and new functionalities through the manipulation of materials at the nanoscale. With applications spanning computing, telecommunications, energy storage, and sensing, nanoelectronics is set to play a critical role in the next wave of technological advancements. As research progresses and challenges are addressed, the field will continue to evolve, driving innovation and reshaping the future of electronic devices and systems.

Key Concepts in Nanoelectronics

Nanoscale Components:

Nanoelectronics leverages materials and components with dimensions on the nanometer scale (1-100 nm), such as quantum dots, nanowires, and carbon nanotubes. These materials exhibit unique electrical, optical, and thermal properties that differ significantly from their bulk counterparts, enabling new functionalities in electronic devices.

Quantum Effects:

CHAPTER 7

Applications of Nanomaterials

Dr. M. Sivanantham and Dr. M. Silambarasan

*Department of Physics, PRIST Deemed to be University,
Thanjavur-613403, Tamilnadu, India*

Introduction

Nanomaterials, defined as materials with at least one dimension in the nanoscale range (1-100 nanometers), have garnered significant attention across various fields due to their unique properties and functionalities that differ markedly from their bulk counterparts. These properties arise from the increased surface area-to-volume ratio and quantum effects at the nanoscale. The versatility of nanomaterials has led to groundbreaking applications in medicine, electronics, energy, environmental science, and beyond, driving innovation and advancing technology in multiple domains.

The applications of nanomaterials are diverse and transformative, offering innovative solutions across various sectors. From advancing healthcare through targeted drug delivery and enhanced imaging to improving energy efficiency and environmental sustainability, nanomaterials hold the potential to address some of the most pressing challenges facing society today. As research progresses and challenges are addressed, the continued exploration of nanomaterials will drive further innovation, shaping the future of technology and improving quality of life worldwide.

Applications of Nanomaterials

Medicine and Healthcare:

Drug Delivery:

Nanoparticles can be engineered to deliver therapeutic agents directly to targeted cells, enhancing the efficacy and reducing side effects of treatments. For example, liposomes and dendrimers are used to encapsulate drugs, allowing for controlled release and improved bioavailability.